

**PUPILS' AND TEACHERS'  
UNDERSTANDINGS OF SCIENTIFIC  
INFORMATION RELATED TO A MATTER  
OF PUBLIC CONCERN**

by

**Isabel Gomes Rodrigues Martins**

A thesis submitted for the degree of  
Doctor of Philosophy of the University of London

Department of Science Education  
Institute of Education  
20 Bedford Way  
London WC1H 0AL

January, 1992



---

---

## ABSTRACT

---

---

The focus of this research is on the interaction secondary school students and teachers had with radioactivity related information. An accident involving radioactive material which happened in Brazil in 1987 provides the context in relation to which the enquiry is framed.

The selected groups' knowledge and perceptions are discussed in relation to topics which include: the conceptualisation of both the nature of physical entities involved and processes which appear to be at work in explanatory accounts of radioactivity; analogies and interpretative schemas as an attempt to go beneath the surface of the most common kinds of misunderstandings; the relationships between the layperson and the scientific information necessary to make sense of scientific/technological events, in terms of students' sources of information, interests and needs as well as self-evaluation of their understandings; the relationships between science and society and the role of secondary education in the context of the communication of such ideas considering its implications for people's daily life.

The empirical study conducted with both students and teachers consisted of a questionnaire and of an interview study. Data derived from the questionnaire is essentially quantitative and was analysed by using multi-variate statistical methods. Data derived from the interviews is essentially qualitative and was analysed using systemic network analysis techniques.

Results are discussed in terms of the implications of understanding better the role of analogies making sense of new information, and the use of knowledge in context as well as the use of pragmatic knowledge, derived from social expectations, for both research on commonsense and to schooling, so as to inform decisions about pedagogic interventions within a Science Technology and Society approach.

**To my parents,  
Dirce and Robison**

---

---

## ACKNOWLEDGEMENTS

---

---

I wish to express my gratitude to my supervisor, Professor Jon Ogborn, for his invaluable assistance and encouragement throughout the course of this work. May I also thank him for stimulating conversations and for being able to learn from his experience, professionalism and expertise.

I am greatly indebted to Susana de Souza Barros and Maria Cristina Dal Pian for their friendship, support and encouragement as well as for their unconditional academic and personal help.

I am also grateful to a group of friends for their help at different occasions. At the risk of omitting some names, I must mention: Ana Tereza Filipecki, Arthur Gomes, Denise Whitelock, Dominique Colinvaux, José Vicente Martorano, Judith Pereira Castro, Fernando Souza Barros, Marcos Elia, my sister Vera Martins Baldi and all my colleagues at the research student group as well as the staff of the Science Department of the Institute of Education.

My deepest gratitude is to the informants of this research and to school teachers and directors who help me during the data collection.

May I also thank my husband, Joel de Lima Pereira Castro Junior, for his care and loving support during these past years. Were it not for his generosity, strong will and for his determination to believe that “we could make good things to happen”, and this project would have never been completed.

SEE/RJ (Rio de Janeiro Secretary of State for Education) is gratefully acknowledged for granting me leave of absence to carry out this project.

CAPES (Brazilian Government) is gratefully acknowledged for financial support.

---

---

# CONTENTS

---

---

ABSTRACT.....	2
ACKNOWLEDGEMENTS .....	4
CONTENTS.....	5
LIST OF TABLES.....	10
LIST OF FIGURES.....	12
LIST OF CHARTS .....	15
CHAPTER I: <u>AIMS, MOTIVATIONS AND PERSPECTIVES</u> .....	18
1.1 The Issue.....	18
1.2 The Problem .....	21
1.3 The Organisation of this Thesis .....	26
CHAPTER II: <u>THE CONTEXT OF THE RESEARCH</u> .....	28
2.1 Introduction.....	28
2.2 The Contexts of Research.....	28
2.2.1 The Theoretical Dimension.....	29
2.2.1.1 Entities of Radioactivity .....	31
2.2.2 The Social Dimension.....	32
2.2.3 The Educational Dimension.....	35
2.3 The Research Questions.....	38
CHAPTER III: <u>DIFFERENT CONTEXTS OF ENQUIRY FOR PEOPLE'S IDEAS IN SCIENCE</u> .....	40
3.1 Introduction .....	40
3.2 An Overview of Different Contexts of Enquiry .....	40

## CONTENTS

3.2.1 The Influence of Cognitive Psychology Studies.....	40
3.2.2 Cognitive Science Studies.....	42
3.2.3 Studies in Science Education.....	44
3.2.3.1 Children's Alternative Conceptions.....	44
3.2.3.2 The Public Understanding of Science.....	49
3.2.3.3 Science, Technology and Society.....	53
3.4 People's Ideas about Radioactivity.....	55
3.5 The Relevance of Such Studies to this Present Research and its Contribution.....	60
<b>CHAPTER IV: <u>ON COMMUNICATING SCIENTIFIC IDEAS</u></b> .....	<b>63</b>
4.1 Introduction.....	63
4.2 A Characterisation of the Material Analysed.....	63
4.3 The Analysis of the Material.....	65
4.3.1 A Model for Text Analysis.....	65
4.3.2 Newspaper and Magazine Articles.....	66
4.3.3 Scientific Popularisation Magazines.....	69
4.3.4 Explanatory Leaflets.....	72
4.3.5 Teachers' Support Material.....	74
4.4 Summary A General View of the Material Analysed.....	75
4.5 Lay Models of Radiation.....	76
4.6 On Explaining an Explanation.....	77
4.7 Conclusions.....	78
<b>CHAPTER V: <u>CHOICES, DECISIONS, CONSTRAINTS AND PRACTICALITIES</u></b> .....	<b>79</b>
5.1 Introduction.....	79
5.2 How can we ask people about what they do not know?.....	79
5.3 Context-free or Context-specific Enquiries.....	80
5.4 The Position to be Adopted.....	82
5.5 Characterising Groups of Interest.....	83
5.6 Research Design Types of Information and Instruments for Data Collection.....	85
5.6.1 Knowledge and Society.....	88
5.6.2 Nature of Knowledge.....	89
5.6.3 Learning and Thinking.....	92
<b>CHAPTER VI: <u>THE PILOT STUDY</u></b> .....	<b>103</b>
6.1 Introduction.....	103
6.2 The Questionnaire Study.....	103
6.2.1 The Sample.....	103
6.2.2 The Instrument.....	105
6.2.3 Summary of Results.....	106
6.2.3.1 Knowledge and Society.....	106

## CONTENTS

6.2.3.1.1 Concrete Recollection .....	106
6.2.3.1.2 Self-Evaluation of Own Knowledge/Understanding.....	110
6.2.3.1.3 Sources of information.....	113
6.2.3.1.4 Self-Evaluation of Own Interaction with Related Information .....	117
6.2.3.1.5 Specific Knowledge held by Students .....	123
6.2.3.2 Summary of Results Concerning Sources of Knowledge .....	124
6.2.3.3 Nature of Knowledge.....	125
6.2.3.3.1 "Is radioactivity like...?".....	125
6.2.3.3.2 Properties Attributed to Concepts.....	129
6.2.3.3.3 Summary of Results Concerning Nature of Knowledge .....	136
6.3 The Pilot Interview Study.....	138
6.3.1 The Sample.....	138
6.3.2 Discussion.....	138
6.4 Final Remarks .....	139
6.4.1 A General View of the Results.....	139
6.4.2 Methodological Points .....	140
<b>CHAPTER VII: <u>STUDENTS ANSWERING ABOUT RADIOACTIVITY</u> .....</b>	<b>142</b>
7.1 Preamble .....	142
7.2 The Sample .....	142
7.3 Knowledge and Society.....	143
7.3.1 Summary of results concerning Knowledge and Society .....	151
7.4 Nature of Knowledge.....	152
7.4.1 Associations and Mental Images How is it like?.....	152
7.4.1.1 An Overall Picture.....	152
7.4.1.2 Differences Between Schools Types.....	156
7.4.1.3 Differences Due To Presentation .....	158
7.4.1.4 Interactions.....	160
7.4.1.5 Summary of Results Concerning Associations and Mental Images .....	160
7.4.2 Properties Attributed to Concepts.....	161
7.4.2.1 Introduction.....	161
7.4.2.2 An Overall Picture.....	161
7.4.2.3 How are students thinking?.....	166
7.4.2.4 Differences Due To Presentation .....	169
7.4.2.5 Differences between Schools .....	178
7.5 Summary of Results .....	179
<b>CHAPTER VIII: <u>STUDENTS TALKING ABOUT RADIOACTIVITY</u>.....</b>	<b>181</b>
8.1 Organisation of the Analysis.....	181
8.2 About the Interviews.....	181
8.3 On analysing the transcripts.....	182

8.4 A First Level of Analysis	
What do students say?.....	188
8.4.1 Concrete Recollection.....	188
8.4.2 Contamination of Distant Bodies .....	190
8.4.3 Can we keep it safe?.....	194
8.4.4 How does it affect the human body? .....	196
8.4.5 Related Topics .....	198
8.4.5.1. Contamination.....	198
8.4.5.2 Conservation.....	199
8.4.5.3 On the Need of a Medium for Propagation.....	204
8.5 A Further Level of Analysis	
How do students think about it?.....	205
8.5.1 Types of Reasoning .....	206
8.5.1.1 Analogical Reasoning.....	206
8.5.1.2 Similarities of Effects equals to Similarity of Causes.....	212
8.5.1.3 Deriving Knowledge from Social Expectations.....	213
8.5.1.4 Semi-Quantitative Reasoning .....	214
8.5.1.5 Knowledge of Properties Triggers Assumptions about Nature.....	215
8.5.2 Summary .....	216
<b>CHAPTER IX: <u>STUDENTS THINKING ABOUT RADIOACTIVITY</u></b> .....	219
9.1 Understanding.....	219
9.1.1 How do students find the text?.....	220
9.1.2 What do the nets say? .....	225
9.1.2.1 Task administration.....	225
9.1.2.2 Overview and Discussion of Results .....	227
9.1.2.3 The Nets as Summaries of the Text.....	237
9.2 How Consistent Are the Results Across Different Contexts?.....	243
<b>CHAPTER X: <u>WHAT DO TEACHERS SAY?</u></b> .....	246
10.1 Organisation of the Analysis .....	246
10.2 Knowledge and Society.....	246
10.3 Nature of Knowledge .....	250
10.3.1 “Is Radioactivity Like...?” .....	250
10.3.2 Properties Attributed to Entities .....	254
10.4 Learning and Thinking	
The Interview Study.....	257
10.4.1 Introduction.....	257
10.4.2 The Sample .....	257
10.4.3 Summary of Results .....	258
10.4.3.1 General Observations.....	258
10.4.3.2 On Teachers' Knowledge of and Opinions about Students' Ideas.....	259
10.4.3.3 On Teachers' Perceptions of Students' Knowledge and Doubts .....	260
10.4.3.4 On Teachers' Predictions of Students' Answers.....	261



## CONTENTS

---

10.4.3.5 On the Difficulties in Explaining Radioactivity.....	263
10.4.3.6 On Students' Typical Responses .....	265
10.4.3.7 On Evaluating the Text.....	265
10.5 Summary of Results.....	266
<b>CHAPTER XI: CONCLUSIONS</b> .....	<b>267</b>
11.1 Introduction .....	267
11.2 Overview .....	267
11.3 Summary of Results.....	268
11.3.1 The Theoretical - Educational Link.....	268
11.3.2 The Theoretical - Social Link.....	269
11.3.3 The Social - Educational Link.....	270
11.4 Implications for Wider Issues .....	272
11.4.1 Further Research .....	272
11.4.2 Curriculum Planning.....	273
11.4.3 Teacher Training .....	274
<b>BIBLIOGRAPHY</b> .....	<b>275</b>
<b>LIST OF APPENDICES</b>	
Appendix 4.1: List of Written Materials Analysed.....	287
Appendix 5.1: Article used the Interview: Contamination of Distant Objects.....	291
Appendix 5.2 Article used in the interview: Can we keep it safe? .....	293
Appendix 5.3: Text used in Interviews.....	295
Appendix 6.1: The Pilot Questionnaire.....	297
Appendix 6.2: Calculation of $\sigma_{\text{máx}}$ .....	303
Appendix 7.1: The Questionnaire used in the Main Study.....	305
Appendix 7.2: Factor Analysis of all Semantic Differential Data.....	309
Appendix 9.1 Semantic Networks.....	313
Appendix 10.1: Teachers' Questionnaire .....	327
Appendix 6.3 : Multidimensional Scaling .....	331

---

---

## LIST OF TABLES

---

---

### CHAPTER III :

Table 3.1: Classifications of STS Science.....	54
Table 3.2: A Summary of Current Studies on People's Understandings of Radioactivity.....	58/59
Table 3.3: Different Contexts of Enquiring for People's Ideas in Science.....	62

### CHAPTER IV :

Table 4.1: A Classification of the Written Materials Analysed.....	64
--	----

### CHAPTER VI :

Table 6.1 Mean Age and Age Range of Students in the Sample.....	104
Table 6.2: Total of "yes answers" Given to Proposed entities in Question: "Is radioactivity, in some way, like...?".....	126
Table 6.3: Evaluative Dimensions Presented in Question 2.....	131
Table 6.4: Factor loadings from Factor Analysis of Question 2.....	135
Table 6.5: Interpretation of Factors.....	135

### CHAPTER VII :

Table 7.1: Mean Age and Age Range for Students.....	142
Table 7.2: Types of Information Presented in Questions About Interests and Evaluation of Understandings.....	146
Table 7.3: Overall Totals for "Is radiation/radioactivity/radioactive material like ...?".....	153

Table 7.4: Factor Loadings from factor Analysis of All Question 1 data.....	155
Table 7.5: Scales for Question 2.....	161
Table 7.6: Interpretation for Factors Derived from Factor Analysis on Data from All Schools for All Presentations.....	167
Table 7.7: Students' choices across Factors.....	169
Table 7.8: Correlations for Means of RN,RY and RM Presentations.....	170
Table 7.9: t-tests for Statistical Significant Differences between Means All Scales in the Three Presentations.....	172
Table 7.10: Correlations to all Scales.....	175
Table 7.11 Correlations for Materiality Scales.....	175
Table 7.12 Correlations for Activity Scales.....	175
Table 7.13 Correlations for Knowability Scales.....	175
Table 7.14 Correlations for all Scales in Different School Groups.....	178

**CHAPTER IX:**

Table 9.1: Nodes and Links Allowed in the Semantic Network.....	226
Table 9.2: Numbers of Nodes and Links per Net.....	227
Table 9.3: Frequencies of Use of Nodes and Links in the Semantic Network.....	228
Table 9.4: A Measurement of Net Structure.....	230
Table 9.5: Another Measurement of Net Structure.....	231
Table 9.6: Number Types of Inferences Allowed by Semantic Network.....	236
Table 9.7: The Nets as Summaries of the Text.....	238

**CHAPTER X:**

Table 10.1: Teachers' predictions about Students Responses to Question: "Is radioactivity like...?".....	251
Table 10.2: Factor Loadings from Factor Analysis on Teachers' Predictions to Students' Responses to "Is radioactivity like...?".....	253

---

---

## LIST OF FIGURES

---

---

### CHAPTER I :

Figure 1.1: A Framework for the Research.....	24
---	----

### CHAPTER II :

Figure 2.1: The Contexts of Research.....	29
Figure 2.2: Role of Science Education in the Relation to Relationships Between Science and Society.....	34
Figure 2.3: A Scheme for thinking About the Rôle of Secondary School in Relation to Both Scientific and Commonsense Knowledge.....	35
Figure 2.4: A Framework for the Discussion of the Rôle of Analogies in Understanding.....	37

### CHAPTER III :

Figure 3.1: Aspects of Research on Children's' Alternative Conceptions.....	49
--	----

### CHAPTER V :

Figure 5.1: General Scheme for Framing the Questions.....	86
Figure 5.2: Relevant Features for Explanations.....	89
Figure 5.3: A Simple Semantic Network to Illustrate the Property of Inheritance.....	95
Figure 5.4: Framework for Interviews with Students and Teachers.....	96

**CHAPTER VI :**

Figure 6.1: Totals for Questions about Evaluation of Previous Knowledge and Need for More Information .....	110
Figure 6.2: Multidimensional Scaling Plot for Question: “ Is radioactivity, in some way, like...?”.....	128
Figure 6.3: Patterns of Answers and Corresponding in the RevMeans vs Concur plot.....	130
Figure 6.4: Reversed Means vs Concur Plot.....	131

**CHAPTER VII :**

Figure 7.1: Cluster Analysis for All Schools and All Presentations.....	154
Figure 7.2: Cluster Analysis for Private School Group.....	157
Figure 7.3: Cluster Analysis for Morning Shift School Group.....	157
Figure 7.4: Cluster Analysis for Night School Group.....	157
Figure 7.5: Cluster Analysis for Radiation Presentation.....	159
Figure 7.6: Cluster Analysis for Radioactivity Presentation.....	159
Figure 7.7: Cluster Analysis for Radioactive Material.....	159
Figure 7.8: Reversed Means vs Concur Plot for Data from All Schools and All Presentations.....	165
Figure 7.9: Reversed Means vs Concur Plot for All Data with Categories Exemplified.....	166
Figure 7.10: Reversed Means vs Concur Plot for Selected Scales Across Presentation as Compared to Overall Totals.....	173
Figure 7.11: Reversed Means vs Concur Plot for Selected Scales Across Presentations as Compared to Overall Totals.....	173
Figure 7.12: Total for Scales Material vs Immaterial and not Composed of Particles vs Composed of Particles for All Presentations.....	176
Figure 7.13: Totals for scales Material vs Immaterial and Tangible vs Intangible for All Presentations.....	176
Figure 7.14: Totals for Scales Materials vs Immaterial and Abstract vs Concrete for All Presentations.....	177
Figure 7.15 Totals for scales Not composed of Particles vs Composed of Particles and Tangible vs Intangible for All Presentations.....	177

Figure 7.16: Totals for Scales Composed of Particles vs Composed of Particles and Abstract vs Concrete for All Presentations.....	177
Figure 7.17: Totals for Scales Intangible vs Intangible and Abstract vs Concrete for All Presentations.....	177
Figure 7.18: Reversed Means vs Concur plot for Selected Scales Across School Types.....	179

**CHAPTER VIII:**

Figure 8.1: Proposed Categories and Distinctions used in the Analysis of Students' accounts.....	184
Figure 8.2: Network summarising Students's Views on Radioactivity....	217

**CHAPTER IX:**

Figure 9.1: A Linear 'Chain' of Nodes.....	229
Figure 9.2: Interconnected Nodes in a Network.....	229
Figure 9.3: Scheme of an Arbitrary Net.....	231
Figure 9.4: Semantic Network MS2.....	232
Figure 9.5: Example of 'Long Chain of Activity I'.....	237
Figure 9.6: Example of 'Long chain of Activity II'.....	237
Figure 9.7: Information that Was in the Nets but not in the Text (I).....	239
Figure 9.8: Information that Was in the Nets but not in the Text (II).....	239
Figure 9.9: Information that Was in the Nets but not in the Text (III).....	239
Figure 9.10: Nature of relationships Between Radiation, Radioactivity and Radioactive Material (I).....	241
Figure 9.11 Nature of Relationships Between Radiation, Radioactivity and Radioactive Material (II).....	241
Figure 9.12: How Radiation Affects Living Tissue.....	242
Figure 9.13: How radiation Affects Matter.....	242
Figure 9.14: Associations Related to the (im)material Nature of Radioactivity, Radiation and Radioactive Material.....	243

**CHAPTER X:**

Figure 10.1: Cluster Analysis for Teachers' predication on Students' answers: "Is radioactivity like...?".....	252
Figure 10.2 RevMeans vs Concur Plot (teachers' data).....	256

---

---

## LIST OF CHARTS

---

---

### CHAPTER VI :

Chart 6.1: Total and Breakdown for Option “Quite Sure” in Question: “How sure you are of remembering what happened ?”.....	106
Chart 6.2: Totals and Breakdown for Answers to Question: “How Many People were Killed in the Accident ?”.....	107
Chart 6.3: Total and Breakdown for “Yes Answers” to Question: “ Did you know anything about radioactivity before ?”.....	111
Chart 6.4: Total and Breakdown for “Yes Answers” to Question: “Was this knowledge enough to understand comments made at that time ?”.....	111
Chart 6.5: Total and Breakdown for “Yes Answers” to Question: “Did you look for information about radioactivity <i>after</i> the accident ?”.....	111
Chart 6.6: Total and Breakdown for Option “one day” to Question: “How long did it take till you were able to realise the seriousness of the situation ?”.....	112
Chart 6.7: Total and Breakdown for “Yes Answers” to Question: “Did you feel capable of evaluating the risks at that time ?”.....	112
Chart 6.8: Breakdown for Options Presented to “Where did you first hear about the accident ?”.....	113
Chart 6.9: Breakdown for Options to Question “Where did you get information about radioactivity before the accident ?”.....	114
Chart 6.10: Breakdown for Options to Question “Where did you seek for information ?”.....	115
Chart 6.11: Breakdown for Options to Question “where did you find information ?”.....	116

Chart 6.12: Breakdown for Options to Question “Who should know about radioactivity ?” .....	117
Chart 6.13: Breakdown for Options to Question “Who actually knows about radioactivity ?” .....	117
Chart 6.14: Breakdown for Options to Question “Most of the information you got at that time related to ...“ .....	118
Chart 6.15: Breakdown for Options to Question “ What are the reasons for seeking for information ?” .....	119
Chart 6.16: Totals and Breakdown for “Yes Answers” to Question: “Were there things you did not understand at that time ?” .....	120
Chart 6.17: Breakdown for Answers to Question “Things you did not understand at that Time Relate to ...“ .....	120
Chart 6.18: Totals for Questions “Information which proved to be helpful...” and “Information which would have been helpful ...” .....	121
Chart 6.19: Breakdown for Question “Information which proved to be helpful ...” .....	122
Chart 6.20: Breakdown for Question “Information which would have been helpful ...” .....	122
Chart 6.21: Breakdown for Answers to Question “Things you still do not understand relate to ...” .....	122
Chart 6.22: Total and Breakdowns for question: “Have you ever heard of...? .....	124
Chart 6.23: Percentages of “Yes Answers” for Each Entity for Each School Group.....	127

## CHAPTER VII :

Chart 7.1: Totals and Breakdown for Answers to Question: “Would you say that the knowledge you have about radioactivity is ...” .....	144
Chart 7.2: Total and Breakdown for Question: “Where did you get your knowledge of radioactivity from ?” .....	144
Chart 7.3: Total and Breakdown for Question/?: “Your interest in knowing more about Radioactivity is ...” .....	146
Chart 7.4: Breakdown for Question: “Which of the Topics below would you be more interested in knowing about ?” .....	146



Chart 7.5: “Things you already knew about before the accident of Goiânia” .....	148
Chart 7.6: Breakdown for “Types of information you looked for” after the Accident of Goiânia.....	148
Chart 7.7: Breakdown for Types of Information You Actually Found after the Accident of Goiânia.....	149
Chart 7.8 Breakdown for Types of Information which Proved to be Helpful to Understand Comments about Radioactivity at the Time of the Accident of Goiânia.....	150
Chart 7.9: Breakdown for Types of Information which Proved to be Helpful to Understand Comments about Radioactivity at the Time of the Accident of Goiânia.....	150
Chart 7.10: Total and Breakdown for Question: “Are there things you still do not understand ?” .....	151
Chart 7.11: Breakdown for Different School Groups in Question 1.....	156
Chart 7.12: Breakdown for Different Presentation of the Questionnaire in Question 1 .....	158

**CHAPTER X:**

Chart 10.1: Total for Question: “In your opinion, students’ interest in knowing more about radioactivity is ...”.....	247
Chart 10.2: Total for Answers to Question: “Where do you think students got more of their knowledge on radioactivity ?”.....	248
Chart 10.3 Teachers’ recollection of Most Common Kinds of Questions Asked by Students at the Time of the Radiological Accident of Goiânia.....	248

---

---

## CHAPTER I

### AIMS, MOTIVATIONS AND PERSPECTIVES

---

---

---

---

#### THE RADIOLOGICAL ACCIDENT OF GOIÂNIA

---

---

In September 1987, presumably around the 14<sup>th</sup>, a Caesium 137 source formerly used for radiotherapy, was taken from an abandoned hospital at Goiânia, an inland city in Brazil, and sold to a junk-yard dealer as scrap-iron. At the junk-yard, the lead shield was opened and the capsule containing approximately 28 grams of Caesium chloride was violated. Because the shiny blue powder fascinated people, it was then separated into pieces and circulated freely, probably for two weeks, until the first victims started to present the first symptoms of radioactive contamination. These symptoms, such as diarrhoea and skin rashes, resembled those from tropical diseases. The suspicion and confirmation that the symptoms were related to radioactive contamination came later. As a result four people died, one had a limb amputated, twenty-one had to be taken under intensive medical care, fourteen suffered from related complications, forty-one were taken to hospital, one hundred and twenty-nine were contaminated either internally or externally. The state of Goiás suffered terrible economical losses, the population all over the country was shocked by the tragedy and a debate about the necessary security measures which are necessary for the use of radioactive materials.

#### 1.1 THE ISSUE

This research relates to the above accident. There are many studies concerning people's specific knowledge of scientific subjects as well as their attitudes and reactions to events related to science and technology. These studies, specially those developed in the U.S., originated from a concern about the quality of science

courses and the consequent training of both specialised technicians and scientists. The main objective of these surveys was to determine what people who had completed formal education knew of science.

Traditionally, the degree of scientific / technological information possessed and the potentiality of interaction with new information of this kind were measured through specific knowledge tests. These tests include a range of scientific subjects selected from school science syllabuses and often contained questions taken from school examinations. The results, in general, indicated that very few people got a high percentage of scientifically correct answers and in this way, it was argued that even educated adults lacked enough knowledge of science.

This methodology, however, has been criticised (Layton, Davey & Jenkins, 1986) on the grounds that it prevents subjects from displaying their potential competence in as much as questions are conceived and answers are evaluated in a framework to which they are not a party.

In most of these and in more recent studies, the need for people to be able to interpret, understand and evaluate information related to scientific / technological matters of public importance is emphasised and an argument for the promotion of the public understanding of science is put forward. This argument plays a central role in justifying the relevance of such studies, in so far as people need this kind of knowledge in order to make decisions about both personal and collective welfare, and should be, either as consumers of products or as qualified workers, able to cope with the demands of an advanced democratic based industrial society. Nevertheless, although this argument is, in one way or another, present in most of the studies in the field, it can be said that behind this superficial consensus there lie profound differences in the objectives guiding and in the approach employed in such studies (Durant & Thomas, 1987).

Apart from the discussion about the aims of promoting the public understanding of science there is a fact that remains as an outstanding issue, namely that scientific / technological knowledge often involves pieces of fundamental science the understanding of which is very hard. It can be said that there is a discontinuity between daily life knowledge about objects and events and the necessary scientific knowledge to understand these objects and events. This discontinuity does not merely relate to the acknowledged high cognitive demand of the subject and can, in

fact, be better understood if we think of science as a collective enterprise which generates knowledge according to certain defined rules of production, validation, communication and evaluation. Within this view scientists are seen as forming a selected and selective group the members of which share a given expertise. Such group is distinguished from other groups in society as possessing authority and competence to judge upon scientific matters.

Another apparently inherent difficulty in discussing scientific / technological matters of public importance is the kind of argumentation present in debates and discussions about these matters where personal concerns and opinions become the major point for discussion, while an understanding of science is somewhat neglected. The communication of this type of knowledge for non-experts is therefore a crucial issue if one is to respect both dimensions of importance of this kind of knowledge. This difficulty entails questions about the role of preconceptions people may have about the subject under question and the kinds of explanations which actually make sense for them.

The aim of this study is not to develop an argument for the promotion of the public understanding of science but rather to try and analyse what would be a suitable methodology for inquiring about people's understandings about matters of public importance, for example radioactivity, and to discuss its relationship with and the implications for current research on commonsense reasoning and mental models. The emphasis will not be related to discussing either people's interpretations of public events related to science and technology or how much currently accepted relevant knowledge they possess about it. The focus will be on people's understandings about that kind of (scientific) knowledge which is (thought to be) necessary to make sense of these events. One of the basic hypotheses made is that people act upon and transform the information received in a dynamic constructivist process. In doing so, previous knowledge and prior conceptions about the way things are, are employed and, as the result of this continuing interaction, an understanding is constructed.

This shift in the object of study makes possible a discussion of the process(es) which occur when people get in contact with new scientific related information (interpreting the new in terms of a familiar background) as well as an analysis of the relevant issues involved in the discussion of the issues related to research on the

public understanding of science, namely aims and techniques of inquiry; problems of representation; and implications of findings.

As far as a clearer understanding of commonsense reasoning is concerned we will be discussing how people understand and make sense of scientific related information about radioactivity, in terms of several categories along which commonsense and scientific knowledge may differ. These categories refer to: (i) the nature of the entities and causal processes involved in both experts' and non-experts' accounts; (ii) the reasons to believe in such explanations; (iii) the communication of these ideas and information and; (iv) the applications of such knowledge. This will be done through the study of people's interpretative and explanatory accounts for their understanding of scientific related information.

There are several reasons which have influenced the choice of this topic. Firstly, because it makes it possible to establish a connection among different research areas within science education as, for example, Children's Alternative Conceptions, Public Understanding of Science. Recent work in the field <sup>of</sup> Mental Models is also relevant in as much as people's ideas can be understood as mental constructions for a given domain in the form of models which have both descriptive and predictive characteristics. Secondly, because it provides an interesting point of departure to discuss the weak link between school science curriculum and the kind of knowledge necessary to interpret these events which relate both to fundamental science and major technological achievements, which, in a broader perspective, has implications for teaching / learning science. It is expected that this discussion will contribute to gaining insight into questions related to the discontinuity between daily life experience and scientific ideas taught at school.

## **1.2 THE PROBLEM**

This research is concerned with an analysis of a piece of scientific knowledge in terms of categories that relate in a broad way to the nature and to the communication of this knowledge. It addresses people's understandings of a specific topic in science framed in the context of a related scientific / technical event. It arose from a concern about the importance of knowing people's ideas and understandings for the purposes of the teaching of science. The topic chosen is one

which highlights the issue of the continuity between everyday conceptions and secondary school science curriculum. This research then asks both general and specific questions about knowledge at three levels:

(i) Firstly, it is concerned with the process(es) of understanding and with the role that previous knowledge plays in it. This entails a discussion about the ways people interpret scientific related information.

(ii) Secondly, it has to <sup>do</sup> with the discussion of the metacognitive basis of such knowledge. The topic chosen, radioactivity, is of special interest in as much as its understanding involves the "manipulation" of unfamiliar entities working under non-obvious mechanisms of causation. The purpose of this discussion is to reach an underlying level of analysis of both the contents and processes involved in making sense of such case.

(iii) Thirdly, it is related to the implications of this discussion for the purpose of communicating such ideas, especially in the context of the current school science syllabuses for secondary school in Brazil. The perspective adopted agrees with the one taken by Shuell (Shuell, 1987) when he states that "*understanding how students learn science is not the same thing as understanding the best ways to teach science to students*". It should be clear that it is agreed that understanding better about cognition and processes of learning certainly helps science educators to gain insight into questions related to coping with problems of learning in a context of formal instruction. Nevertheless, the direct application of the findings already achieved by research on students' ideas should be preceded by a more fundamental level of discussion of what lies underneath the most common types of misconceptions.

The general research question is about:

---

<i>People...</i>	<i>...Interacting with...</i>	<i>...Information.</i>
<i>How do</i>	<i>make sense</i>	<i>scientific information</i>
<i>students and teachers</i>	<i>interpret</i>	<i>about matters of</i>
	<i>evaluate</i>	<i>public importance?</i>
	<i>understand</i>	

---

In order to discuss what is involved in dealing with ideas which have both public and scientific importance taking into account educational implications it was decided to analyse the case of radioactivity. It has scientific importance and significance as well as public importance through its applications in Medicine and power generation, for example, and is not currently taught at either primary or at secondary school level in Brazil.

In our case, in order to discuss the issues mentioned above, we will take the example of an accident with radioactive material that happened in 1987 in Brazil, which was widely covered by the media (see page 18). On this occasion topics such as radioactive contamination, applications of radioactivity and security and control measures currently employed were the object of discussion all over the country. People got very upset by a tragedy that resulted in injuries and deaths, economic losses for an, until then, prosperous region giving rise to a discussion about risks and security concerning nuclear energy issues.

At that time the general public had contact with the facts about the accident through wide coverage by the media. The unexpectedness of such an event and the lack of satisfactory knowledge about radioactivity related issues caused nation-wide concern about the possible causes and probable consequences. Radio, newspapers, magazines and television informed about the circumstances which made it possible for the accident to happen, the measures of security and control taken and some related information about the nature and effects of ionising radiation.

This accident illustrates very well how a piece of fundamental science, traditionally distant and remote from people's everyday experience, may suddenly become a matter of importance. It also illustrates how the comprehension of the facts and their consequences are dependent on some kind of knowledge about the nature of radioactivity, how it works, the evidence one has to believe so and on the way these ideas are communicated.

The research questions are related then to the interaction of selected groups with selected information from the media. The questions are about people's conceptualisation of radioactivity, the types of explanation related to it and the ways information is both organised and communicated.

It is in this sense that this work deals with people's understandings about matters of public importance. In the interpretation of both scientific and "popularised" accounts people do make use of their prior knowledge. Most of the material people make contact with relates to major technological achievements and requires an understanding of pieces of fundamental science.

Our interest in secondary school is because it plays a role of an interface between two distinct worlds: the everyday world where people have contact with the effects and consequences of science and the scientists' world with its own practices and organisation. Secondary school science is thus seen as an interface in as much as at this stage these two worlds are still undifferentiated for students have not chosen which career to follow.

The research questions divide into: (i) background general questions; (ii) questions about the processing of information; (iii) questions about people's conceptualisations. They reflect the three levels of inquiry that is aimed at. These questions will be asked both at a general and specific level in relation to a background which relates the rationale chosen.

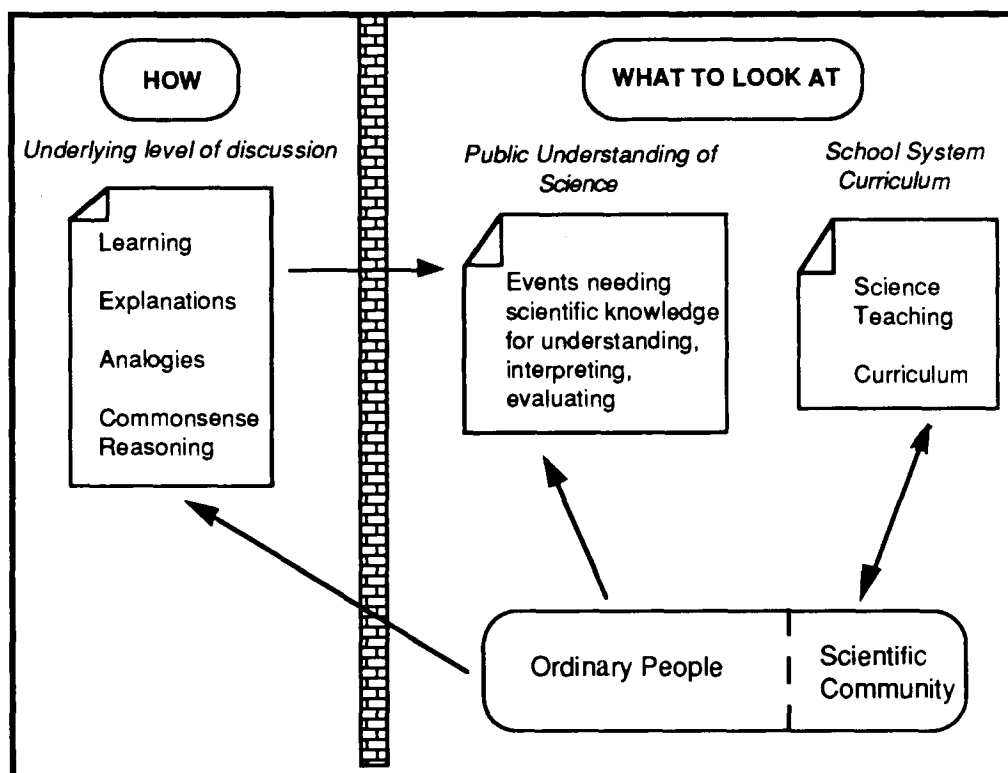

Figure 1.1: A Framework for the Research



Figure 1.1 summarises a view in which the interpretation and understanding of some events which happen in our daily life may depend very much upon a certain kind of scientific / technological knowledge. These events relate to a wide spectrum of topics such as diseases, power production, etc, having in common the characteristic of being related to both fundamental science and major technological achievements.

The relationship between scientific/technological events and the basic science which is thought to be necessary to understand them is not, as far as school science syllabuses are concerned, a direct one. Among the reasons for this may be the very tradition of academic science as well as the fact that explanations of such events often involve advanced science with a high level of cognitive demand. Nevertheless the line of argument to be pursued here will claim that the distance between events of everyday experience and the explanations provided by science are much more strongly related to the way scientists work and interact with one another and with other institutions within society.

The view in which science is regarded as an institution within society which has particular rules for eligibility, production and communication helps us to understand why there is such a degree of discontinuity between scientists' and ordinary people's discourses. Within this perspective scientific knowledge is regarded as "public knowledge", the fruit of a collective enterprise in order to pursue a consensual view which is achieved by mutual scrutiny (Ziman, 1984). These ideas will be elaborated further when the role of secondary school science as an interface between two distinct worlds, namely the world of real experience where people interact with the effects and consequences of science and the selected community (élite) which actually aims at producing knowledge, is considered.

The main point we want to emphasise here is that, taking into account their limited possibilities of interacting with currently accepted scientific information in as much as it is not part of either common culture or normal schooling, ordinary people have almost no other alternative than interpreting these events using their common knowledge. It is against a background of ideas constructed out of experience that facts and events are evaluated. Our concern is with the way analogies from commonsense are employed in this process. That is the reason for locating the discussion at an underlying level where issues related to understanding and explanation are focused.

### **1.3 THE ORGANISATION OF THIS THESIS**

This thesis is organised as follows.

Chapter 1 defines the objectives, scope and potential contributions of the research.

Chapter 2 presents an argument for an approach to the problem of studying people's understandings of scientific information related to matters of public concern which considers its theoretical, social and educational implications.

Chapter 3 discusses different contexts of enquiry of people's ideas in science in terms of main research paradigm features and locates this research within this framework.

Chapter 4 contains an analysis of how different contexts of written communication deal with the topic of radioactivity and identifies problems concerning the communication of scientific ideas to a lay audience.

Chapter 5 reviews research techniques used in related studies and describes the framing of the enquiry and the instruments, the sample used in the data collection.

Chapter 6 presents the results of a pilot study concerning relevant background information about students' interaction with radioactivity related information at the time of the accident of Goiânia and contains methodological considerations related to modifications made to the instruments of data collection to be used in the main study.

Chapter 7 discusses the results of the main study referring to a questionnaire and to an interview study which investigate students' sources of information as well as their conceptualisations of radioactivity.

Chapter 8 presents the results of the interview study conducted so as to understand better both the content of students' explanations and their forms of explaining about radioactivity.

Chapter 9 investigates the ways previous knowledge may affect the understanding of new related information.

Chapter 10 relates to a parallel study conducted with teachers where they make predictions about and give their opinion about students' ideas and the difficulties involved in teaching and learning about radioactivity.

Chapter 11 summarises the main results in connection with the research questions, and discussing their implications for wider issues such as further research and curriculum planning.

---

---

## CHAPTER II

### THE CONTEXT OF THE RESEARCH

---

---

#### **2.1 INTRODUCTION**

Most of the studies concerning pupils' and the public's ideas about scientific / technological events start from the assumption that even educated people seldom are able to interpret / understand / evaluate questions related to this kind of scientific / technical knowledge which are important not only for both personal welfare and decision making but also for matching the needs of an advanced democratic society.

Sometimes the scientific explanations of these events make reference to unfamiliar entities and non-obvious mechanisms of causation. The fact that these events have to do with major technological developments which relate to people's everyday experience and also that it involves advanced (fundamental) science gives relevance to making the issue of explanations the main emphasis of the present study. It is expected that, through an analysis of the types of explanation people give, some aspects of the structure of commonsense interpretative models will be uncovered. That involves the study of the nature of the entities involved, the nature of the processes which work in each case and the nature of the causation involved.

#### **2.2 THE CONTEXTS OF RESEARCH**

There are three related dimensions, the analysis of which helps to situate the research in the field of science education and to justify the choice of the theme for the present study. They are the social (S), the educational (E) and the theoretical (T) dimensions (figure 2.1).

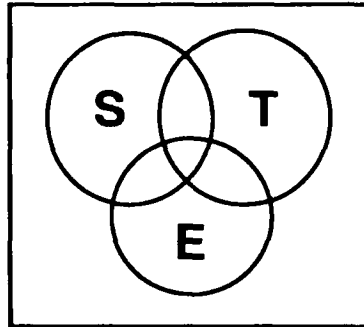

Figure 2.1: The Contexts of Research

The educational dimension has to do with the the objectives and aims of the teaching of physics; with the conceptual demands and general implications of the concepts to be taught and with the role of students' prior knowledge in the interpretations they make of such events. The social dimension is related to the discussion of the need for a better public understanding of science, as well as to the attempts to conduct educational initiatives inspired by the slogan "science for all" and to the concept of scientific literacy. The theoretical dimension is concerned with the ideas and the conceptualisation different groups of people, including scientists, have about the subject.

### 2.2.1 THE THEORETICAL DIMENSION

Paradoxical as it might appear, the most frequent encounters between the lay person and science in everyday life relate, in general, to both fundamental science and major technological achievements, which are not at all easy to grasp, in their entire complexity, unless one has mastered a solid background of science. This seems to be the case for understanding the damage that chlorofluorocarbons may cause to the ozone layer which rests on a discussion that involves complex chemical reactions, exchanges of energy towards an equilibrium of reagents, etc. The same holds for Genetic Engineering and its references both to intricate long chains of protein molecules which carry sophisticated and unique codes and to enigmatic entities called genes. And what about making sense of the appalling behaviour of invisible and microscopic agents that cause devastating effects on people's immunological system by, intelligently, camouflaging themselves and learning the body's own defence instructions.

Information about Genetic Engineering, the Greenhouse Effect and the HIV virus and AIDS, though relating to different subject areas, illustrate the impact rather specific scientific knowledge has on ordinary people's lives. This reveals a quite strong paradox, that is, that the contexts in which science most commonly appears in everyday life may involve unfamiliar entities and refer to elaborate theories. Radioactivity is another example of this kind. Discussions about decisions for sites to build nuclear power stations or to store nuclear waste are often found in media reports. Similarly some applications of ionising radiation, such as uses of radionuclides to treat malignant tumours or to sterilise surgical material or to help food preservation, are increasingly becoming part of ordinary people's daily lives.

One aspect that is common to all the examples mentioned above is the fact that scientific explanations of them involve reference to intangible invisible entities which can only be detected or perceived through their effects.

Another problem which seems to impair the understanding of such matters is their inherent remoteness from any kind of personal experience. Unlike other kinds of physical objects, it is not possible to experiment with genes or with ionising radiation in the same way one experiments with moving objects, for example. The possibility of experimenting and trying out by direct action with immediate feedback is therefore precluded in these cases. Thus the question about how one gets to know such kinds of objects appears as not only interesting but also as of extreme relevance.

One of the hypotheses to be made is that analogies could be employed as a means of first order approximation when trying to make sense of such information (section 2.2.3). The possible existence of commonsense models, analogies or schemes applied to the interpretation of particular ideas, is proposed as an attempt to go beneath the surface of the most common kinds of misunderstandings.

For this reason, knowledge about people's conceptualisations of both the nature of the entities and the causal processes involved in a certain event would be essential if we want to provide a basis for constructing such commonsense models. Information about whether the entities in question are: (a) seen as material or as a property; (b) considered something active or passive; (c) better understood in terms of part or whole; (d) contingent or necessary; and about the nature of the causal

processes involved in the explanation of such an event, is all necessary if we are to establish a basis for such models.

Therefore, what has been called here the theoretical dimension is also related to our interpretation of how people's knowledge about a given subject is constructed. In the next section we present a brief account of a possible theoretical basis which substantiates the theoretical dimension.

### **2.2.1.1 Entities of Radioactivity**

Rom Harré (Harré, 1986), has the idea of dividing putative referents of scientific discourse into three realms with respect to the possibilities of human experience.

*Realm 1* is the realm of possible experience which concerns the world of cognitive objects with pragmatic properties. Theories of this type allow a discussion of the constitution of these objects and to classify and make predictions about observable phenomena, Newtonian kinematics being an example of such type of theory.

*Realm 2* relates to cognitive objects with iconic properties and to a system which is not, for practical reasons, available for observation, but whose existence has been somehow anticipated through theoretical means. Plate tectonics is an example of such a type of theory which has instances in psychology and sociology as well, which will differ, of course, in relation to the kind of unobserved system represented.

*Realm 3* is the domain of theories which enable the representation of non-picturable beings, an example of such theories being Special Relativity. The cognitive objects here have mathematical or formal properties, and refer to systems which cannot be directly observed by human beings in principle.

The boundary between Realm 1 and Realm 2 is flexible and depends on technological achievements which enable an enhancement of the possibilities of interacting with beings of Realm 2. As there are different ways in which a being can be "beyond all possible experience", boundaries for Realm 3 are not well defined, being dependent on a change in the epistemic status of beings through advances which then permit new empirical tests to be carried out.

Radioactivity can be thought of as a being belonging to Realm 2 in as much as it relates to a class of unobservable beings which are however representable and

accessible provided difficulties of a practical order can be overcome. Making sense of such kind of being must involve answering of two questions: "*To what kind does the being in question belong?*" "*By what process (or mechanism) was it brought into question?*" (Harré, 1986, p.194). These two questions are about the ontology attributed to the entities under question and can be considered as encapsulating basic elements which are present in people's explanations.

The contribution of these ideas to the discussion of people's explanations is one which relates to the ways analogies are employed in explaining. Ontology, processes and causation are qualities which are preserved through analogies (Harré, 1986) and it is in this sense that they will be regarded as providing a basis to start a discussion of commonsense explanations.

Explaining is critical to the process of understanding. In order to construct an understanding of the way people, things and events behave one seeks for explanations. Types of explanation depend on how deeply one needs to go into the matter under question, that is, they become more and more complex as the need to understand becomes stronger. This all starts with an attempt to find a "*hypothetical world in which a given action or a set of actions make sense*" (Schank, 1986, p.30). In this thesis, some account will be given, based on data, of the way people imagine or hypothesise radioactivity.

### 2.2.2 THE SOCIAL DIMENSION

The social dimension scientific activity is regarded as essentially a social enterprise and the scientific community as a self-regulating organism which possess clear rules of organisation, well defined criteria for membership, established means of communication and mutual scrutiny. Two approaches within sociology, appear to be useful here. The expression *internal sociology of science* refers, among other things, to scientists' practice in academic research and to their interactions as professionals in the production of valid trustworthy knowledge. Questions which arise under this perspective relate to criteria to achieve *consensuality* over rational matters which involve activities such as experimenting, validating, theorising and communicating (Ziman, 1978). The expression *external sociology of science* refers to how science relates to other institutions in society, emphasising the interrelationships and mutual effects.



It is, in fact, the potential effects and consequences of the interaction between science and society in general, that provides the basis for a rationale for research on the Public Understanding of Science. The promotion of the public understanding of science would reflect a higher level of scientific literacy of the population in general. This increased level of literacy would then be reflected in benefits to all parts in the chain. Those would be:

(a) benefits to science itself as, because of the increased appreciation of scientific activity and achievements, the number of people interested in pursuing a professional career in Science would increase;

(b) benefits to society: as scientific literacy increases, the possibilities of interacting with and benefit from modern life technologies also increase;

(c) benefits to the state: a better educated population can make better informed decisions about matters of public concern involving policies for research and development.

All these assumptions rest on the premise that an increased knowledge of science has direct positive outcomes in people's attitudes towards Science and its applications. That may be too optimistic a way of thinking, considering the complexity of some of the issues involved, such as ethics, relationships with the state, etc.

Research on the public understanding of science has therefore the main objective of providing grounds for informed decisions about initiatives related to increasing people's level of scientific literacy. Such initiatives may be conducted both within the educational system and on a broader scale in connection with informal learning institutions like, for example, museums. In any case, it is still possible to identify the *mediating* role of institutions in society (schools, museums, specialised magazines, etc) in making the scientific explanations intelligible to a wider audience.

It is important to stress that the relationships between science, technology and society are complex, especially when seen in relation to common knowledge (lay person's knowledge). Although from the Science point of view, Science is seen as disjoint from Technology, from the point of view of common knowledge they are

bonded together. The idea here is that both scientific and technological knowledge are actually disconnected from common knowledge. Nonetheless the effects of Science and Technology are not disconnected and what the lay person experiences in his/her everyday life is the interaction with those effects in various and non-systematic ways.

Figure 2.2 represents this situation by representing two distinct levels of interaction with science. At one extreme there is the scientific community, a restricted group, seen as an élite, which acts in the context of the production of knowledge. At the other extremes there are ordinary people, understood here broadly as non-science professionals, who are excluded from the context of production of scientific knowledge though suffering the impact of scientific discoveries and technological artifacts very strongly. Popularisation of science is the activity through which the scientific community communicates with ordinary people. There are magazine and newspaper articles, broadcast programmes, etc where well-reputed scientists get their message across. Technology and its related events and applications permeate both "worlds". Science Education can be seen as interacting with all worlds when professional training is considered at primary, secondary and tertiary levels. At the same time this picture illustrates the dissociation between the scientific community and ordinary people's interactions with knowledge in science and technology, and also introduces into the discussion the role of another institution in society, namely the Educational System, as providing a means of bridging the gap between the two.

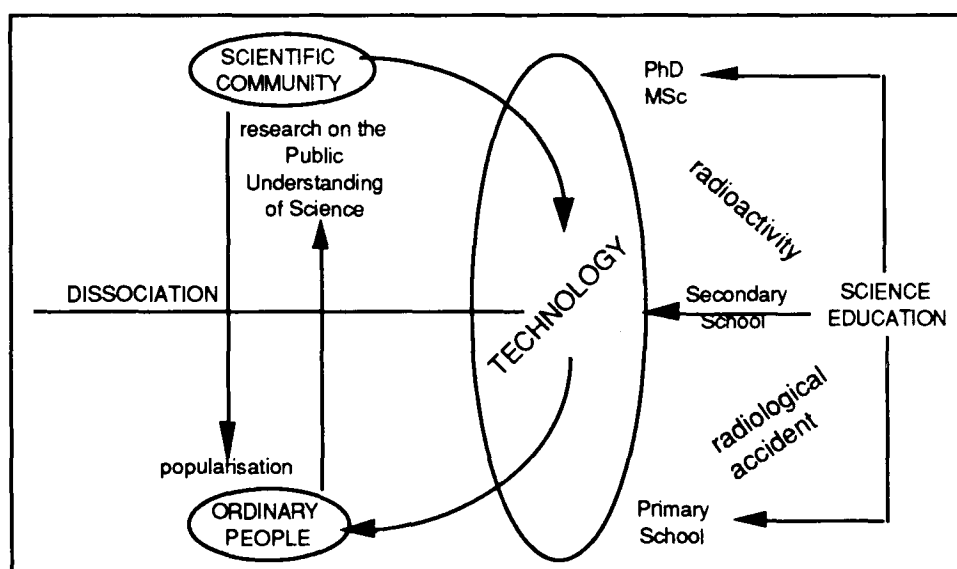

Figure 2.2: Role of Science Education in relation to relationships between Science and Society.

Putting together the social relations of science, school and of effects of science in everyday life, we have the picture summarised in figure 2.3.

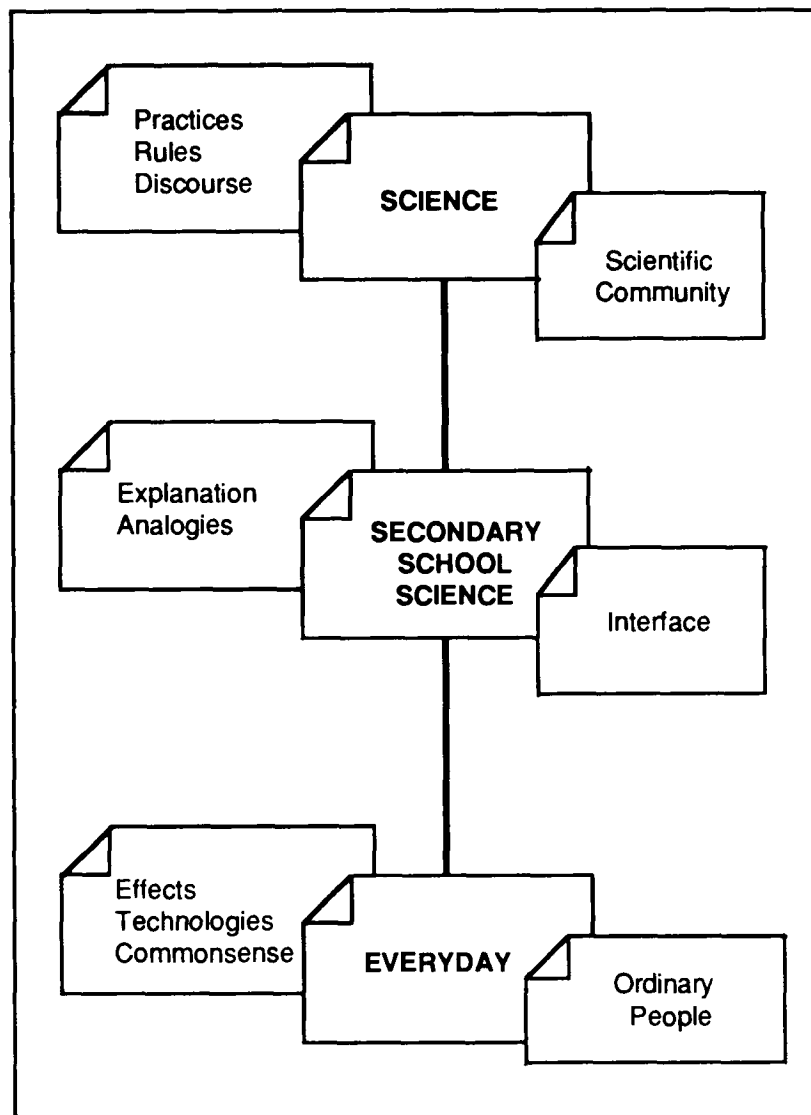

Figure 2.3: A scheme for thinking about the role of secondary school in relation to both scientific and commonsense knowledge.

### 2.2.3 THE EDUCATIONAL DIMENSION

Some topics, which are necessary to understand scientific explanations about events involving fundamental scientific / technological achievements, are not present in school syllabuses. In spite of this, students come to the classroom and ask their teachers questions about these events, their consequences and implications. The

kinds of explanation proposed by both students and teachers will be strongly influenced by their conceptions about the subject and by the nature of their previous information. The study of the negotiation of an explanation and the compromise of different views are then interesting matters, worth studying.

It is part of the job of a teacher to present new topics to students. In doing so, he or she has to deal with the problem of giving an account of the current scientific conception in order to promote students' understanding. However, new as the topics in questions might be, teachers should be aware that students frequently have some kind of prior knowledge about the subject matter. These ideas held by students may be either a mere familiarity with the related scientific vocabulary or a deeply rooted conception of how things work and occur. Whatever is the case, these prior notions have to be taken into account when one aims at promoting knowledge, because they will influence and shape the ideas and the understandings the students construct.

In discussing people's explanations of radioactivity our main concern will be to identify the most common types of analogies from commonsense which are assimilated in the processing of information. One of our assumptions will be that the explanations will give an account of the new and unfamiliar in terms of the familiar and intelligible.

Some kind of analogical reasoning is often employed. The term analogy is used here as denoting the process through which explanations are accounts of the new and unfamiliar in terms of the familiar and intelligible. Figure 2.4 shows an attempt to describe analogies as a first approximation when one tries to make sense of unknown objects and events.

Firstly there is a superficial level in which similarities between entities, mechanisms and processes are identified. When confronted with a situation where some explanation about some unfamiliar event or object is needed, a very common procedure to adopt is to try and find some other object or event that resembles in some respect to the one we want to explain. One starts by comparing the two in order to establish similarities and differences between them. This permits the making of conclusions and predictions about the unfamiliar object or event, based on properties and characteristics of the familiar object or event we think it resembles.

Once this analogue is defined, further similar aspects are sought. These can be similar entities, causes, processes and ways of "functioning". There is, however, another level of similarity to be sought which is related to identifying the necessary qualities which constitute the basis of similarities in an analogy. They refer to basic categories upon which knowledge rests namely ontology (what is happening?), causation (why is this happening?) and process (how is this happening?).

As argued by Harré when he states his principle of robustness (Harré, 1986) these are qualities that do not change through a transformation in which the nature of the entities is preserved. If this is the case for analogies, then this provides an interesting point of departure for discussing their role in accounts from science and commonsense.

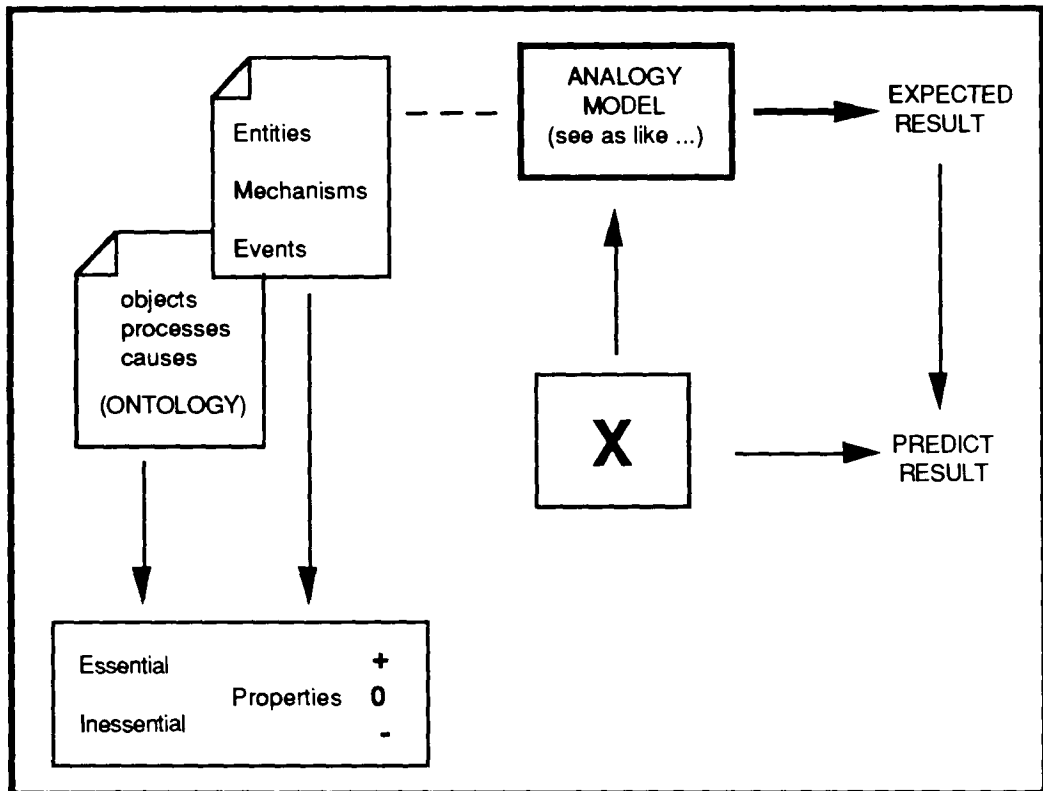

Figure 2.4: A framework for the discussion of the role of analogies in understanding

### **2.3 THE RESEARCH QUESTIONS**

The issues mentioned in the discussion above refer to the relationships between knowledge, schooling and commonsense. These are quite complex issues and there is not a clear-cut way of dealing with them unproblematically. They involve ultimately an analysis of the rules through which knowledge is produced in the context of science and the kinds of adaptations and "translations" which are made for the purpose of its communication at school. Within this view commonsense knowledge stands as another body of knowledge the understanding of which is necessary for the elaboration of the nature of these "translations".

The discussion of these issues will be made in the present study through an analysis of the structure of commonsense explanations in a perspective in which their role in the communication of ideas in science is prioritised. For this reason, a model of what may constitute the basic features of this kind of explanation was proposed. At this stage it is a tentative way of trying to find out what such features might be and whether they have counterparts in scientific explanations.

Bearing these issues in mind, we will be asking both general and specific questions. Examples of general questions that relate to how people conceptualise the topic are:

- \* *What are people's conceptions about the nature of radioactivity?*  
Is it seen as a property?  
Is it considered to be material?  
What is it made of?
- \* *What are people's conceptions about the causation processes related to radioactivity?*  
What does it make happen?  
Which effects does it produce?  
How does it interact with other entities?
- \* *How do people see themselves in relation to this knowledge?*  
What counts as evidence in phenomena related to radioactivity?
- \* *How are scientific ideas communicated to among people?*  
How different pieces of information about radioactivity are interpreted?  
How are descriptions about radioactivity related phenomena made?  
What is the kind of argumentation involved in discussions about radioactivity?  
To what extent are explanations "negotiated" and "agreed"?

**\* *What do people know about radioactivity?***

How far are practical and conceptual aspects of radioactivity from each other?

What kind of understandings do people have about technological aspects of radioactivity?

In which perspective are people interested in radioactivity?

There are also questions that concern the processing of information when people try to make sense of scientific related information about radioactivity. These are questions such as:

**\* *What is the role of prior conceptions in understanding?***

What kind of ideas about radioactivity do people hold?

Where do people get information about radioactivity?

To what extent does prior knowledge shape people's understandings of new information?

**\* *What lies beneath the most common types of misconceptions?***

In which respect do people's ideas differ from the currently accepted view about radioactivity?

Which underlying assumptions are made about the nature of radioactivity?

Which are the modes of explanation present in people's accounts of radioactivity?

**\* *How are analogies and schemas from commonsense assimilated?***

Are analogies present in people's explanations of radioactivity and its related aspects?

Are analogies employed when people explore and try to make sense of radioactivity?

What types of analogies are most commonly used (analogies of nature, cause, or process)?

The analysis of such questions has implications for another level of discussion related to the teaching / learning of such kind of topic. In fact, the general background questions are:

**\* What are the reasons for the weak link between school science curriculum and the knowledge about major technological developments?**

**\* What are the reasons for the weak link between school science curriculum and fundamental science necessary to understand scientific / technological events?**

**\* What would be the status and importance attributed to children's ideas in a context of formal instruction of these topics?**

---

---

## CHAPTER III

### DIFFERENT CONTEXTS OF ENQUIRY FOR PEOPLE'S IDEAS IN SCIENCE

---

---

#### **3.1 INTRODUCTION**

This chapter reviews research in three areas of Science Education. They are: Children's Alternative Conceptions in Science; the Public Understanding of Science; and Science, Technology and Society. Whilst the first two areas are well established research programmes in the field, it was not until recently that the argument for considering the third to have a similar status was put forward (Aikenhead, 1990a; Solomon, 1988). Apart from that, some reference will also be made to research focusing on people's ideas about physical phenomena from a perspective of both Cognitive Psychology and Cognitive Science, in particular that from research on Mental Models. The chapter contains a discussion of the research areas mentioned above and treat them as different contexts in which people's ideas have been an object of investigation. It presents an analysis of the different objectives and outcomes of selected pieces of research, followed by results of current research on people's ideas about radioactivity. It is intended that this discussion will enable a more detailed formulation of the research questions as well as locating the potential contribution of this particular study in a wider perspective.

#### **3.2 AN OVERVIEW OF DIFFERENT CONTEXTS OF ENQUIRY**

##### **3.2.1 THE INFLUENCE OF COGNITIVE PSYCHOLOGY STUDIES**

The interest in children's understandings about the physical world is not new, dating back to Piaget's studies on children's ideas about physical phenomena (Piaget, 1929). Piaget's major concern was to arrive at a theory of how children construct knowledge through their interactions with the world, in a developmental



perspective. Thorough and systematic investigation done over a fifty year period, enabled him to provide an account of a genetic epistemology. He also devised a specific methodology and techniques of enquiry which include the piagetian clinical interview. Best understood within a structuralist framework, Piagetian Genetic Epistemology introduces the idea of the epistemic subject as an abstraction used to describe how knowledge is constructed, in a dynamic process of re-arranging of ideas through continuous feed-back from interactions with the world. The notion of 'construction' is crucial and more important than any particular information on perception, memory, etc, as it describes the process through which mental operations are developed through action.

Piagetian theory has inspired a substantial amount of research on the development of the child's learning skills in the area of Cognitive Psychology. The implications of Piagetian theory for education and the consequent recommendations for practical work, encouraging the manipulation of concrete materials (Kubli, 1979), selection of syllabus so as to match children's developmental stages (Shayer & Adey, 1981), etc, have also been the subject of discussion and controversy.

Many studies in the area of Children's Alternative Conceptions make reference to the Piagetian Genetic Epistemology as a framework of analysis of data which suggested the existence of patterns of responses which appeared to be independent of cultural variables and to show some regularity with age (Driver & Erickson, 1983; Gilbert & Swift, 1985) . More recently, notions which, according to a piagetian framework, constitute a basis for thinking, such as, for example, conservation and reversibility, have been investigated in connection with the commonsense understanding of natural phenomena (Ogborn, 1989). The adherence to a Piagetian framework entails a commitment to a view where the internalisation of early actions upon the world constitute a basis for building up more complex structures of thinking (Whitelock, 1990; Bliss & Ogborn, 1991).

Not all research on children's alternative conceptions was done within a piagetian framework. Kelly's Personal Construct Theory has been used as a basis to understand the nature of children's ideas (Pope & Gilbert, 1983)). Ausubel's theory of learning, which emphasises the role of anchoring concepts, in his own terminology called subsumers, in the process of meaningful learning (as opposed to rote learning) has also been employed to explain the way children's ideas change with time (Nussbaum & Novak, 1976).

Despite differences in the theoretical positions adopted by many researchers, it seems that there is a consensus towards a 'constructivistic' position, that is, whatever the nature or the status to be attributed to children's ideas is, the child is seen as an active participant in the learning process (Driver, Guesne & Tiberghien, 1985).

### 3.2.2 COGNITIVE SCIENCE STUDIES

Research on Cognitive Science deals with topics traditionally discussed in Cognitive Psychology from a computational perspective. Much of the work in this area concerns the characterisation of human understanding of the real world. Examples of notions proposed to explain the nature of this understanding are, amongst many others, scripts (Schank & Abelson, 1977), mental models (Johnson-Laird, 1983; Gentner & Stevens, 1983) and frames (Minsky, 1975). The methodology used is eclectic and encompasses different techniques of knowledge acquisition, mainly used in psychology, and different models of knowledge representation. More specifically, research on mental models, aims at representing naturalistic human knowledge about simple physical or mathematical systems within a framework of computational semantics as developed by Artificial Intelligence.

By considering the different perspectives adopted by researchers in the field, Brewer (Brewer, 1987) compares the notion of schemas, mental models, causal mental models and situational models. *Schemas* can be defined as pre-compiled generic knowledge structures, which possess different structural properties depending on the cognitive domain and that modify incoming information producing a memory representation of this incoming information. *Mental models*, as seen by Johnson-Laird, are structural analogues of the world on which thinking acts. *Causal mental models* (which relate to what is referred to as a mental model in Gentner & Stevens's book) involve the inherent need for a domain-specific construct of causality in the representation of physical systems, be it in terms of spatial relations or in terms of human intentionality. Causality also plays an important role in giving explanations of physical phenomena. Lastly, situational models are seen as an amalgamated construct which describes the representations of text comprehension in terms of "an integrated structure of episodic information,

*collecting previous episodic information about some situation as well as instantiated general information from the semantic memory” (van Dijk & Kintsch, 1983, p.344).*

Therefore, the basic general assumption made by this research is that people build internal mental models of the objects they interact with as well as of themselves (Norman, 1983, p.7). Although issues concerning the underlying knowledge structures, their representations, and their relationships with other already possessed knowledge are present in different pieces of work, there is not a consensus about the nature of such mental representations. Nonetheless, according to Williams et al (Williams, Hollan & Stevens, 1983), mental models are seen by most people as: (a) composed of autonomous objects with an associated topology; (b) able to be 'runnable' by means of local qualitative inferences; (c) able to be decomposed and; (d) having the ultimate function of modelling the effects of changes in a system in a qualitative way. Studies of people's mental models are of special interest in so far as they discuss different characterisations for the kinds of knowledge people may associate with a given domain, in terms of its nature (e.g. analogical, abstract, etc) as well as in terms of its structure (e.g. hierarchical, fragmented, etc). For example, people's ideas may be seen as “remarkably well-articulated naive theories of motion which are consistent across individuals”, with patterns of errors being predictable from these theories and their elaborations (McCloskey, 1983). On the other hand, people's knowledge may also be considered as a collection of fragmented loosely connected ideas. diSessa proposes the notion of phenomenological primitives (diSessa, 1983) as abstractions from experience which are self-evident and non-problematic, as constituting the basis for naive physics explanations. He goes even further by coining the expression “*knowledge in pieces*” to refer to intuitive physics and contraposes this view to that which considers intuitive physics to possess features such as commitment and systemacity (diSessa, 1989).

The relevance of this research programme for science education is quite clear, though the implications of many of its findings rest at a theoretical level and not in terms of straightforwardly large-scale applicable technologies for education. It is by discussing the issues traditionally related to learning from a different perspective, that this research may provide helpful insights into both students' conceptualisations of physical entities and strategies of problem solving, so as to yield a basis for a discussion about both human and machine learning.

### **3.2.3 STUDIES IN SCIENCE EDUCATION**

From the perspective of science education, research on children's ideas grew out of a pragmatic concern. The discussion about new teaching strategies and the development of didactic materials which characterised the science education scenario in the late fifties and during the sixties were rooted in two main factors: limited achievement of science students at all levels together with the need for training both scientists and science technicians in face of the constant increasing demand for technological development. It is in this context that science projects, (such as the PSSC, The Physical Science Study Committee and the Harvard Project Physics in the United States), as well as teaching projects (such as the PSNS, Physical Science for Non-Science Students and the Nuffield Science in the United Kingdom) appeared. Alternative approaches to the teaching of science also appeared. Examples of these are Integrated Science and the emphasis on the importance for children to be taught about scientific processes and to develop and acquire scientific skills. In so far as the difficulties related to teaching/learning science are concerned, it is possible to say that, overall, all such experiences contributed to gain more insight into the nature of the problems. Nevertheless, extensive evaluative studies show that many of the difficulties students had persisted despite efforts made to improve the quality of the teaching leading to severe criticisms like that by McConnell stating that science curriculum projects of the 1960s and 1970s failed to generate the results expected of them in terms of improvement of scientific literacy for the general public (McConnell, 1982, p.2).

#### **3.2.3.1 Children's Alternative Conceptions**

Research on children's alternative conceptions in science<sup>1</sup> is based upon the proposition that students possess their own forms of explaining the physical world and that this prior knowledge might affect subsequent learning. This proposition was put forward in the early seventies as one strong justification for enquiry into

---

<sup>1</sup>The label 'alternative conceptions' is not the only one that is used to refer to children's ideas about the real world and to their own forms of explaining physical phenomena which do not conform necessarily with the currently accepted scientific view. Several terms are used to refer to them and there is not a consensus concerning the terminology to be used. The origins and implications of this variety in nomenclature is discussed later in this chapter.

children's ideas in various topics of the school science curriculum. To the psychological and pedagogical bases of this statement, a value dimension was added, namely that children's ideas should be respected in their own right and taken into account when planning instruction. Such propositions were put forward in a form which was general enough to be compatible with different schools of thought and their corresponding re-interpretations for practice.

The number of studies investigating children's 'alternative conceptions' in science has grown considerably in the last two decades and, nowadays, can be seen as a strong research programme in the field of Science Education. Bibliography compilations (Duit & Pfundt, 1991) reveal that the number of articles quoted in 1991 is about three times the number of articles quoted in 1985 in a compilation done by the same authors (Duit & Pfundt, 1985). Research in the field now covers children's conceptions on a wide range of topics in Physics, Chemistry and Biology, the relationships of these conceptions with other subject areas, such as, for example, cognitive development and history of science as well as reports of approaches to teaching taking students' conceptions into consideration.

As the number of studies in the area increased, so did the variety in the terminology used to refer to children's conceptions. Examples are 'children's alternative frameworks' (Driver & Easley, 1978), 'misconceptions' (Helm, 1980), 'children's science' (Gilbert, Osborne & Fensham, 1982), among many others. This diversity in nomenclature reflected another kind of diversity, namely that of the theoretical frameworks adopted, methodologies of data collection, frameworks for analysis of results and implications of the findings. Thus, in so far as both the nature of these 'constructions' and the process through which they might happen are concerned, there is no consensus among researchers, although a constructivistic view is generally assumed, either implicitly or explicitly.

At first, most of the work done in this area consisted of different surveys of children's ideas about different topics of the school science curriculum yielding a great deal of material in the form of descriptive reports. At this stage, the curriculum served not only as a guide to topics of enquiry but also as a framework of analysis for the data obtained. Scientific knowledge was, therefore, considered as a reference against which the findings could be interpreted, a view which is consistent with the intention of improving the teaching of science.

A number of questions concerning the nature of these conceptions, the regularity of some patterns of response, their consistency across contexts, their evolution with age, etc, proved to be of interest and became the object of empirical investigation. After nearly two decades of extensive research, a substantial amount of knowledge about children's ideas about a wide range of topics of the science curriculum is now available. The necessity of making sense of this accumulated knowledge at a more general level and to discuss its educational implications led to different lines of enquiry. Some of these lines are described below.

(i) Alternative Conceptions and History of Science: Many studies had already identified a certain level of similarity between some of the ideas children were found to have and the early forms of explanations given by scientists in the past when first investigating some physical phenomena, as reported in history of science accounts. One example is the similarity between some students' explanations about movement, inertia and the ideas of the 'impetus' theory<sup>2</sup> (Viennot, 1979; Clement, 1983; McCloskey, 1983). This similarity could also be identified in other areas, being remarkably strong in some cases. Nonetheless the interpretation that follows the recognition of these similarities varies. Consider the example of Wiser & Carey's historical case study of the evolution of thermal theories and the discussion of its implications for naive-expert shift (Wiser & Carey, 1983). In their view, the similarity between both the content and the progression of novice's and 18<sup>th</sup> century scientists' representations cannot be generalised until a more complete study of students' conceptualisations in the subject is done. Furthermore, and in congruence with a Kuhnian position, they say that an analysis of the domain and of the exploratory mechanisms and concepts of each conceptual system, must be done and can only be properly judged in the context of the theories in which concepts are embedded. At the other extreme, there are studies which propose a direct transposition of conclusions which are valid in one context to the other. For example, Wandersee (Wandersee, 1985) claims to have shown evidence that knowledge of historical misconceptions can help anticipate students' misconceptions. The view to be taken here is that this latter position still needs to be

---

<sup>2</sup>This exemplified by the belief that what preserves the movement of a launched body, after it has lost contact with the mover, is the effect of an internal force - an impetus - imparted on it by the mover, which happens to bear an remarkable similarity with forms of explanation proposed by de Marchia and Buridan (Franklin, 1978).

based upon by stronger theoretical arguments and substantiated by empirical evidence.

(ii) Constructivism, Alternative Conceptions and Conceptual Change: One of the long term issues about research on children's ideas is the utility of this knowledge for the improvement of the teaching of science. Within a constructivist position, these ideas would play a major role in learning as the child is constantly incorporating new experiences and re-constructing his/her understanding, which evolves and changes with time. Differently to a tabula-rasa approach, which portrayed the learner as a recipient to be filled with knowledge, according to a constructivist position, acknowledging children's ideas should constitute the first step towards the eventual appropriate pedagogic action to promote the understanding of physical phenomena. The processes through which this is seen as able to occur generally include three major stages, namely, awareness, conflict and re-structuring (Hewson, 1981). The common point is to get to know children's ideas and take them into consideration when planning instruction. At the level of proposing cognitive models for conceptual change in childhood, an argument for analysing conceptual change in the context of theory change has been put forward by Carey, so as to characterise developmental changes and help understand resistance to learning (Carey, 1987, p.161).

(iii) Social Influences and Language: The influence the social environment and, more specifically, of language, might have on children's ideas has also been the object of investigation. Context-dependency is seen as crucial to understand the reasons why children may use different strategies of reasoning, different vocabulary or to evoke different kinds of entities when dealing with the same problem depending on the context of enquiry, for example, in the classroom and in everyday life (Solomon, 1983). Cultural influences of language have also been discussed in terms of the role of metaphor (Black, 1962), in terms of the effects of language on the structure of our common ways of thought (Arcà, Guidoni & Mazzoli, 1983; 1984), in terms of its role in the formalisation of the understanding of different concepts which are associated with the same word in a given language (Proverbio & Lai, 1989).

In so far as the orientations of research are concerned, it is possible to identify two main lines. These two positions will be called *fundamental* and *pragmatic*, without by giving them these labels attributing greater value to one or to the other. The former position is characterised by a strong commitment to providing an account of why children present 'alternative' ideas in terms of underlying structures of reasoning. The attempt to identify stereotypical types of motion and to relate their genesis to early action in the sensori motor period (Whitelock, 1990; Bliss & Ogborn, 1991) is an example of this position. Another example is the basic modes of thinking proposed by Arcà et al (Arcà, Guidoni & Mazzoli, 1983; 1984) or Andersson's "gestalt of causation" (Andersson, 1986).

The pragmatic position is committed to providing an account of how children's ideas are organised and how they change with time. Within this perspective, research results are important inasmuch as they inform (i) further research on conceptual change strategies and; (ii) development of teaching schemes aimed at promoting conceptual change. One example of work conducted within this orientation is Hewson's (Hewson, 1981). Osborne and Wittrock's model for learning science (Osborne & Wittrock, 1983) also emphasises the role of children's prior knowledge and experiences in the active process of generating meaning from incoming information. The constructivist teaching schemes proposed by the CLIS Project group (Scott et al, 1987; Needham et al, 1987) also rest upon the belief that teachers' knowledge of the child's prior conceptions facilitates proposing strategies that help the development of an awareness of own ideas, the possibilities to try out such ideas in different contexts, comparisons between two conflicting ideas, etc.

Although both types of work contain a descriptive element, what is seen as problematic and, therefore defining the object of study differs. In what was called the fundamental stance, the objects of study are modes of thinking and reasoning and the aim of the enquiry is to provide an explanation of why children's ideas are what they are. In the pragmatic stance, the major concern is with the improvement of the teaching and learning of science, with children's ideas being regarded as useful information upon which the development of didactic materials should be based.



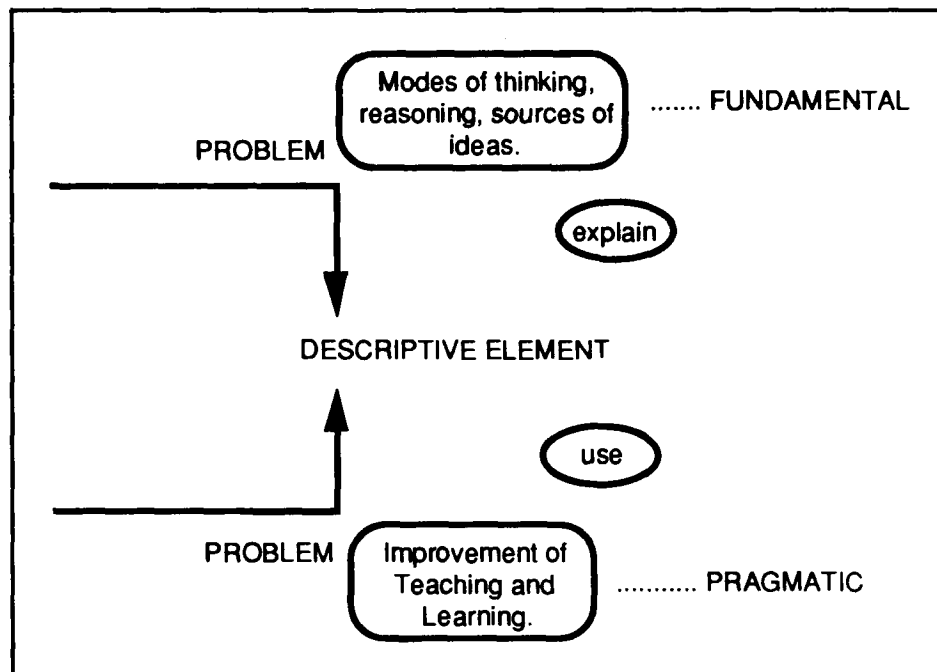

Figure 3.1: Aspects of Research on Children's Alternative Conceptions.

The classification is not, however, meant to be a strict one, as both elements may be present in most of the work mentioned. Its value rests on the provision of a scheme to characterise the 'state of the art' in the field by discussing predominant features in different pieces of work and not by attaching labels to them. By viewing them in this perspective it is possible to see that most of the theoretical references used in the interpretation of the findings come from Psychology with little reference made to social influences in the genesis and development of alternative conceptions<sup>3</sup>. It is also possible to see that very little information about teachers' knowledge of and attitudes towards children's ideas, in the context of formal instruction, is available.

### 3.2.3.2 The Public Understanding of Science

Another context in which people's ideas in science have been an object of investigation is that of research on the Public Understanding of Science. The expression 'the public understanding of science' is broadly and frequently used to refer to the knowledge possessed by people, in general, about scientific matters. However, examining more deeply the contexts in which this expression is likely to

<sup>3</sup>For a complete review about different positions in sociology and its consequences for interpreting children's alternative conceptions see Solomon, (1986). Also for a formulation of research questions in science education within a sociology framework see Delamont (1989).

appear, it is possible to observe different connotations it acquires. This point was raised by Durant & Thomas (Durant & Thomas, 1987) when discussing the different meanings which could be attributed to the words 'public', 'understanding' and 'science' and the different ideas which they might be used to represent. They say that, looking more closely at the way the argument unfolds, it is possible to identify "*profound differences of orientation, of outlook and aim*" beneath a superficial consensus of rationale, topics and methodologies of enquiry.

Research in the area of the public understanding of science initially concentrated on surveying, in quantitative terms, people's general knowledge of and attitudes towards science and technology. Within this line of enquiry, the investigation usually employs large scale opinion surveys, and the answers are analysed against a background of scientific knowledge so as to detect how far one deviates from the other. The general motivation for this research is to assess the level of interest and the knowledge possessed by non-specialists, and the findings are discussed in terms of their implications for society and the corresponding actions that should be taken to assure that the general public is capable of informed decision making. They are also discussed in terms of establishing desirable standards of scientific literacy (Miller, 1983a).

In order to assess how much the general public knew of science, their interests and needs in so far<sup>as</sup> scientific /technological knowledge is concerned, many opinion surveys have been conducted in Europe and in the USA focusing on topics such as: the relationships between science and society; the influence of the media on people's ideas; general interest in and specific knowledge of topics in science; the profile of the scientist and his role as a professional in society; and so on. The enquiry was directed to specific topics within science and technology as well as to events which relate to these topics. The information obtained was often quantifiable and was analysed against a schooled frame of reference.

Results of such surveys revealed that the high level of interest people reported themselves as having was not accompanied by a high level of understanding. Findings of extensive studies such as the Assessment of Performance Unit (APU) in science in the UK (DES, 1986), and the National Science Foundation survey in the US, (NSF, Science Indicators, 1983; 1985 and Miller, 1983b; 1986) revealed people's ignorance about matters concerning science as well as their limited memory for topics taught at school. Another comprehensive survey, which

presented similar findings, was that conducted by the Commission of the European Communities (CEE, 1977; 1979). More recently, results of parallel surveys conducted both in the UK and in the US (Durant, Evans & Thomas, 1989) shows similar results, with perhaps an increase in interest in scientific matters but still showing low levels of knowledge in science. Another common feature is that, unlike other subjects (e.g. politics, sport, etc), there is a mismatch between interest and 'informedness' in the case of science and technology.

A high level of interest in science is also reported by Delacôte (Delacôte, 1987) when describing the data from questionnaires published in a monthly journal for readers aged 10-15 years old and which were returned by a sample of approximately three thousand 12-13 year olds. Results also show that scientists are considered by children as competent professionals who work in groups and reveal an image of scientists essentially as men of action who are benefactors to all humanity. Another interesting result is that television is the most preferred medium for scientific information but some reference is also made, though in a much lower proportion, to specialised magazines, books and museums, whereas school is only mentioned as a source by one in four children.

As far as similar studies conducted in Brazil are concerned, in a recent survey<sup>4</sup> a sample of 2,892 adults from urban areas and from all social classes were asked about their interest in scientific/technological affairs as well as about their knowledge of specific scientific/technological achievements (CNPq, 1987). The results of this survey, which employed face-to-face interviews, show that one in five people say they are interested in knowing more about science and technology. The level of interest in both subjects increases with schooling and socio-economic background<sup>5</sup> and is higher for men than for women and for young people than for old people. In addition, according to two thirds of informants, there should be more or better information about science and technology available in the media. People's knowledge of scientific discoveries proved to be better for those who possess a higher interest in science, it being important, however, to stress that the level of

---

<sup>4</sup>This survey was commissioned to Gallup Institute of Public Opinion by The Ministry of Science and Technology, more specifically to two of its agencies: The National Council for Science and Technology (CNPq), which funds scientific research in the country and abroad, and the Astronomy and Related Science Museum (MAST), which is devoted, among other objectives, to promoting the popularisation of science.

<sup>5</sup>Level of schooling is, in fact, strongly dependent of the socio-economic background of an individual, which makes both variables highly correlated to interest in studying science and in scientific discoveries.

schooling is also higher for this group. Scientists have essentially a positive image which tends to be, perhaps, more idealised and naive for the less interested group. Science is also considered by the public as an activity whose positive consequences are greater than its negative ones. Scientists are regarded by nearly two thirds of the sample as “educated people who produce good things for mankind”, though those less interested in science tended also to view scientists as “intelligent people who work a lot but have no intention of becoming rich”.

More recently, a number of studies have been conducted concerning how people actually interact with and use their knowledge in and about science. Within this line of enquiry selected groups in society are encouraged to discuss their points of view about issues in science and technology which have direct relevance for their lives. This contextualised approach takes into consideration the argument that different audiences may have different interests and needs regarding scientific/technological matters (Durant & Thomas, 1987) and that, consequently, a greater level of commitment would be achieved by ‘unscripted’ group discussions about specific topics which are relevant to specific groups.

The methodology of enquiry employs interview techniques intended to allow an informal and spontaneous discussion to take place. Those are mainly group discussions which can be both video and tape recorded. The methodology employed is mainly a situational one (Cohen & Manion, 1989, p.33), that is, the focus of researcher's attention is on how subjects negotiate their interpretations of the social contexts they find themselves in, though some reference is also made to the linguistic aspect and to the structure of a grammar of argumentation (Solomon, 1988).

One example of on-going research within this situational perspective is a study of teachers' processing of scientific information and the kinds of understandings they can make out of pieces of science which can be found in the media (Hann, Brosnan & Ogborn, 1991). Teachers are required to talk at length and on different occasions about their understandings of scientific information. More important than yielding knowledge about teachers understandings about a variety of subjects such as the greenhouse effect, genetic engineering and food preservation, the methodology also enables learning to take place, with teachers finding group discussions valuable and useful in as much as they enable a clarification of their previous ideas on the subject.

### **3.2.3.3 Science, Technology and Society**

Still within Science Education, there has been an increasing concern about children's views on the relationships between science, technology and society. Recommendations from The Royal Society in the UK (The Royal Society, 1985) stress the importance of ensuring that those who would be non-science professionals have a better understanding of science and technology, focused on matters of public concern, so that people could appreciate the contribution of science and technology to mankind as well as being aware of their limitations and relationships with other institutions in society. Within this framework, many science curriculum materials have been devised and applied. Assessment of students' views on issues related to science, technology and society before and after science courses within a STS approach contain a great deal of information about children's views on topics such as the nature of science, scientific methods, scientific processes and skills, scientists as professionals, as well as on their knowledge of and attitudes towards major scientific/technological achievements.

Aikenhead (Aikenhead, 1990b) places such pedagogic interventions in a spectrum where it is possible to identify the different modalities of curricular interventions. They range from using STS issues as extra motivation in traditional science courses to the systematic study of STS issues as a distinct body of knowledge. Table 3.1 summarises this analysis.

This classification makes most sense within a framework in which STS is considered a body of knowledge in its own right (Ziman, 1984). It is clear that curriculum materials within a STS approach differ in terms of the contents to be taught in order to promote socially relevant science learning. Among the contents commonly selected are: (i) understanding of science concepts; (ii) relationships between scientific knowledge and technological applications; (iii) discussion of philosophical aspects, such as, the nature of scientific enquiry, the nature of scientific explanation, etc; (iv) the role of professional scientists and of the scientific community in society; (v) the impact and the consequences of science and technology for the lay person; (vi) the ideology of STS education and its relationships with politics and economics; (vii) STS education as an awareness of a wider contemporary humanistic problematics, such as peace campaigns and the preservation of the environment.

DIFFERENT CONTEXTS OF ENQUIRY FOR PEOPLE'S IDEAS IN SCIENCE

*"STS education is too complex and diverse to be grasped or presented as a completely consistent and thoroughly integrated academic discipline. But we can give our students some idea of the connections - including contradictions - between its various aspects. One might even think of it as a gem stone, whose facets are less interesting than the edges and corners where they meet."* (Ziman, 1990, p.9)

CATEGORIES OF STS SCIENCE	ASSESSMENT	EXAMPLES
<b>MOTIVATION BY STS CONTENT</b> : Standard school science mentioning STS to make it more interesting.	Students are <u>not</u> assessed on the STS content.	Commonly found in teachers' practice in the classroom.
<b>CASUAL INFUSION OF STS CONTENT</b> : Standard school science plus short study of STS topic attached onto science topic	Superficial and minute assessment on STS (95% Science, 5% STS).	SATIS (ASE, UK)
<b>PURPOSEFUL INFUSION OF STS CONTENT</b> : Standard school science plus short studies of STS content integrated to science topics so as to explore systematically STS content.	Students are assessed to some degree on their understanding of STS content (90% Science 10% STS).	Interactive Teaching Units for Chemistry (UK, Newcastle Polytechnic).
<b>SINGULAR DISCIPLINE THROUGH STS CONTENT</b> : STS serves as an organiser for science content and its sequence. Science content is selected from one science discipline.	Students are assessed on their understanding of both STS and Science though with greater emphasis on Science (80% Science, 20% STS).	Harvard Project Physics (US); PLON Project (University of Utrecht, Netherlands).
<b>SCIENCE THROUGH STS CONTENT</b> : STS serves as an organiser for the science content and its sequence. The content of science is multidisciplinary.	Students are assessed on their understanding of both STS and Science though with greater emphasis on Science (70% Science, 30% STS).	The Dutch Environmental Project (University of Utrecht, Netherlands); Salters' Science Project (University of York, UK).
<b>SCIENCE ALONG WITH STS CONTENT</b> : STS is the focus of instruction and relevant science enriches this learning	Assessment is done about equally on both STS and Science content (50% Science 50% STS).	Science & Technology 11 (Canada, Victoria: BC, Ministry of Education)
<b>INFUSION OF SCIENCE INTO STS CONTENT</b> : STS is the focus of the instruction. Relevant science is mentioned but is not systematically taught.	Students are primarily assessed on STS and only partially on Science.	SISCON (UK, ASE)
<b>STS CONTENT</b> : A major technological or social issue is studied and science content is only mentioned to indicate an existing link to science.	Students are <u>not</u> assessed on science content.	Science & Society (UK, ASE)

Table 3.1: Classifications of STS Science (from Aikenhead, 1990b)

### **3.4 PEOPLE'S IDEAS ABOUT RADIOACTIVITY**

The subject of people's ideas about radioactivity has been investigated, although studies focusing specifically on this subject are not numerous. Reference will also be made to such studies as well to other work, which involves fundamental related concepts.

Radioactivity has been investigated in both small and large scale studies. Large scale studies have generally the form of big surveys about people's knowledge of scientific facts and attitudes towards science and technology. In such studies, superficial factual questions are asked to a large sample about a wide spectrum of scientific/technological knowledge with public importance. Small scale studies, employ a much smaller sample and, can be either classroom studies where both factual and interpretative questions are asked or intensive ethnographic studies conducted with selected groups. Large scale studies are more likely to be found in the Public Understanding of Science research tradition whereas small scale studies, such as classroom observations, evaluation of applications of STS teaching programmes and use of knowledge by selected groups in contextualised group discussions, can be found in both Children's Alternative Conceptions and in the Science Technology and Society studies.

The theoretical background of such studies, although not very explicit, mentions what was early identified as the 'power argument' and emphasises the necessity of providing reliable information which can help people to live in the modern scientific technological world (Lucas, 1988) and on which people can base their judgments about questions that are vital to welfare and to the future of the world (Ronen & Ganiel, 1988).

Some authors mention the possible connections of research on public knowledge, with research on children's alternative conceptions in science. In this perspective, both expert and lay models are regarded as mental models, rather loosely defined as "*discrete bits of information and ideas*", constructed for a given knowledge domain (Eijkelhof & Millar, 1988).

Table 3.2 summarises the objectives, techniques for data collection, and results obtained for a range of studies which dealt both directly and indirectly with people's ideas about radioactivity.

Although the studies reported here have different objectives their findings show a great deal of similarity and consistency. The most striking results are the existence of an undifferentiated radiation concept which is used to refer to both radioactivity and radioactive material. However, an interesting point made by Klaassen et al (Klaassen et al,1989) is the fact that this indeterminacy of words does not seem to matter in ordinary communication. They relate this fact to a pragmatic attitude people have in everyday life where there is no need for deep theoretical explanations ( a view consistent with Schutz & Luckmann's ideas on the social construction of reality (Schutz & Luckmann, 1974) ).

Another interesting connection made by Klaassen et al (Klaassen, Eijkelhof & Lijnse,1989) is that the kinds of ideas people hold about radioactivity conform with Andersson's proposed experiential gestalt of causation (Andersson, 1986) which is inspired by Lakoff & Johnson ( Lakoff & Johnson, 1980), that is, a common core in life-world predictions and explanations which suggest that "causation is an experiential gestalt" consisting of " a number of different components which together establish" a concept of causation "which is more fundamental than its parts", namely agent, instrument and object. An example of this would be "radiation (as instrument) from Chernobyl (as agent) affects us (as objects)".

Table 3.3 shows much of the information available about lay ideas about radioactivity comes from the Public Understanding of Science or from the Science, Technology and Society research paradigms. One exception is, perhaps, the work of Gick & Holyoak (Gick & Holyoak, 1983) which, from a cognitive science-oriented approach, examines situations which make reference to effects of ionising radiation on living tissue which are also discussed in terms of analogical problem solving. They show that people are able to identify and use suitable analogies in problem solving, even when they come from a remote domain.

Finally, results from the Brazilian survey on people's knowledge show that nuclear power is ranked in second in people's choices for scientific discoveries which are



dangerous to mankind. The use of science and technology for war purposes, in particular, in the case of a nuclear war, was mentioned by a third of the respondents as negative consequences of science and technology.

Further relevant information for understanding people's ideas about radioactivity comes from studies of children's conceptions of matter. According to different studies in the field (Séré, 1985, 1986) students have difficulties in understanding the material nature of gases. They also consider air and gas as different things. Students' conceptions of atoms and molecules were also found to involve a projection of macroscopic properties onto the microscopic world (Andersson, 1990). In his study, Andersson identifies a conflict between the "*continuous, static, no vacuum conception*" and the "*particulate, dynamic, vacuum*". Examples of these are conceptions of matter as filling all space or of molecules as placed in a continuous medium. Studies reported by the the CLIS project group (Brook, Briggs & Bell, 1983) about children's ideas of the particulate nature of matter reveal that they think matter is not necessarily in continuous motion, that there is air between particles and that molecules can themselves melt in a solid to liquid change of state.

DIFFERENT CONTEXTS OF ENQUIRY FOR PEOPLE'S IDEAS IN SCIENCE

	<b>OBJECTIVES AND ASSUMPTIONS</b>	<b>METHODOLOGIES</b>	<b>RESULTS</b>
Durant, Evans & Thomas (1989)	To assess the general public's level of "informedness" by asking how much science the general public understands, what their understandings of the processes of scientific enquiry are as well as their specific interests in knowing more about science.	Face-to-face interviews so as to obtain answers to open-ended, multiple choice and rating scale types of questions.	<ul style="list-style-type: none"> <li>- About a third of the respondents either did not know or thought that radioactive milk could be made safe to drink by boiling.</li> <li>- Almost 50% said they believed nuclear power stations cause acid rain.</li> <li>- Nearly three quarters of the informants knew about the existence of background radiation.</li> </ul>
Lucas (1988)	To gather data about the knowledge of some members of the general public about simple scientific ideas.	Face-to-face interviews with 1033 British people aged 15 or over. Questions were chosen to be at about the level expected of a grade 4 CSE candidate. Different types of question (tru/false, multiple choice, etc) asked.	<ul style="list-style-type: none"> <li>- Overall tendency to think that radioactivity has a life-time of 10-1000 years.</li> <li>- Radioactivity is something dangerous and is composed of chemicals mixed together.</li> <li>- Radioactivity is invisible in the atmosphere and cannot be stopped.</li> <li>- Magnetism induces radioactivity.</li> <li>Radioactivity is harmful for all living things.</li> <li>- Radioactivity is highly toxic and medium level radiation is still harmful.</li> </ul>
Eijkelhof & Millar (1988)	To assess both experts' and non-experts' understandings of radioactivity and ionising radiation.  Accounts from the media are free from researchers' influence and consequently more spontaneous.	Analysis of selected extracts from British newspapers which date back to the coverage of the nuclear accident at Tchernobyl by the media.	<ul style="list-style-type: none"> <li>- Lack of differentiation between the terms: radiation, radioactive material and radioactivity.</li> <li>- Radioisotopes are hardly ever mentioned.</li> <li>- Units are sources of confusion.</li> <li>- Radiation /Radioactivity have a definitive life-time.</li> <li>- Radiation cannot be seen smelt or tasted and is strongly associated with risk and danger.</li> <li>- There is no clear distinction between irradiation and contamination.</li> </ul>

DIFFERENT CONTEXTS OF ENQUIRY FOR PEOPLE'S IDEAS IN SCIENCE

	<b>OBJECTIVES AND ASSUMPTION</b>	<b>METHODOLOGIE</b>	<b>RESULTS</b>
Conforto, Giova & Signorini (1989)	- To discuss how the 'nuclear' subject should be approached by school and how to introduce related topics to young people at the level of secondary school.	Questionnaire applied before and after Tchernobyl accident in a sample of 1023 people aged 16-24 (half of them were secondary school students and half were university students).	<ul style="list-style-type: none"> <li>- High percentage of students is aware that x-rays are an ionising radiation.</li> <li>- Knowledge of medical uses of radiation is poor with students showing confusion.</li> <li>- Family background and level of schooling did not appear to be sources of substantial differences between the two groups studied.</li> </ul>
Klaassen, Eijkelhof & Lijnse (1989)	To compare two different approaches in the teaching of radioactivity: the traditional approach (presentation of molecular and atomic models extended to a nuclear model followed by the introduction of the topic radioactivity and a microscopic treatment of ionising radiation) and the approach where everyday life situations involving ionising radiation are part of the teaching sequence (as in the PLON project).	Use of pre- and post-tests, interviews, analysis of text-books and classroom observation. The study was conducted with pupils from the 5th and 6th forms from the high ability band and with 3rd and 4th formers from the middle ability band.	<ul style="list-style-type: none"> <li>- Confusion between the concepts of molecules, atoms and substance.</li> <li>- Attribution of macroscopic properties to microscopic entities.</li> <li>- Use of an undifferentiated concept of radiation.</li> <li>- Conservation of radiation.</li> <li>- Fear of radiation.</li> </ul>
Ronen & Ganiel (1988)	To study a methodology of teaching which encourages students to adopt an informed approach in relation to scientific knowledge with public importance.	Appraisal of different situations concerning exposure to low levels of radiation by both students and educated adults. Classroom activities included: lectures, problem solving, group or individual assignments, open discussions.	<p>A consistent pattern was identified concerning situations and their corresponding levels of exposure:</p> <ul style="list-style-type: none"> <li>- High exposure: TV rays and power plant.</li> <li>- Medium exposure: Unusual situations</li> <li>- Low exposure: daily-life activities.</li> </ul> <p>All students and most teachers reported that their gradings were "intuitive", based on well-known facts.</p>
Eijkelhof, Klaassen, Lijnse & Scholte (1990)	To make an inventory of lay ideas about radioactivity as perceived by experts so as to inform elaboration of teaching materials.  Experts were thought of as having come across lay ideas because of the nature of their work.	40 experts took part in a two-stage Delphi study. Experts should inform how often they had encountered specific lay ideas as well as to add any lay ideas that had not been mentioned in the questionnaire.	<ul style="list-style-type: none"> <li>- Radiation, radioactivity and radioactive material are not distinguished. Neither are activity and radiation dose.</li> <li>- Radioactive substances are always dangerous.</li> <li>- Food irradiation makes food radioactive.</li> <li>- Nuclear power stations can explode like a bomb.</li> </ul>

Table 3.2: A summary of current studies on people's understandings of radioactivity

### **3.5 THE RELEVANCE OF SUCH STUDIES TO THIS PRESENT RESEARCH AND ITS CONTRIBUTION**

Table 3.3 summarises the main characteristics of the five different contexts in which people's ideas in science are most commonly investigated. Approaches within Science Education tend to make reference to well-established bodies of knowledge, their interactions with one another and with society as a whole. This reference is evident not only in the selection of topics for enquiry but also as a basis for a framework of analysis. Still within Science Education, commonsense may be given this same status of a body of knowledge considered in its own right. This kind of reference is not so explicit in Mental Models studies and virtually non-existent in those from Cognitive Psychology.

Within Science Education the status attributed to people's ideas can be seen as dependent on their degree of congruence with scientifically accepted ideas (Children's Alternative Conceptions). They can also be seen in terms of their relevance to a selected audience (Public Understanding of Science). On the other hand, within Mental Models and Cognitive Psychology, it is the nature of people's ideas that is the object of discussion with reference to both functional and epistemological considerations.

There is no simple way to group together the focus of different research paradigms of research. Their focus can express the distinction between form and content as applied to people's explanations for natural phenomena (Children Alternative Conceptions). It can also reflect the importance attributed to the amount of knowledge people happen to possess (Public Understanding of Science) or the importance of discussing STS issues. On the other hand, Cognitive Psychology and Mental Models appear to be equally concerned with identifying mechanisms which underlie intelligent behaviour.

A variety of techniques of data collection is employed. Research on Mental Models and on Cognitive Psychology tends to rely more on qualitative data whereas Science Education there seems to be balance between qualitative and quantitative data, with STS perhaps making more use of transcripts of group discussions as data.

The way the results are seen differs for the different research paradigms. There is an argument concerning whether children's conceptions and mental models can be regarded as structured or not. Mental Models are also discussed in terms of novice/expert shift, which parallels the emphasis given to using the Children Alternative Conceptions research results as helping to clarify models of conceptual change. Public Understanding of Science research results can be analysed with or without reference to a context. Decontextualised approaches normally regard results as measuring the amount of information or the specific bits of knowledge held by a person. Contextualised approaches generally make reference to the use to be made by or the needs of selected groups in society. Results can also be treated so as to make comparisons between different groups' uses of and needs for knowledge. Results of research on STS reveal the extent to which students possess or not the necessary discursive skills to debate as well as the relevant scientific / technological knowledge to make informed judgements about STS issues. Mental Models and Cognitive Psychology research results concern a more fundamental and general kind of issue, namely the nature of the reasoning strategies and mechanisms involved in the learning processes.

At the level of implications, work on Children's Alternative Conceptions, Mental Models and Cognitive Psychology have clear and direct implications for understanding the learning process, whilst Public Understanding of Science and Science Technology and Society relate more to knowledge-in-action.

Using the categories proposed in table 3.3, it is possible to draw a clearer picture of where the present work stands. The reference taken is a scientific/technological real life event, in the context of both formal and informal learning. Students' ideas are seen in terms of the conceptual structures behind them. The enquiry concentrates on the sources of information, the nature of knowledge possessed by students and how this knowledge is used to make sense of new related information. Techniques for data collection are various and differ with the main emphasis of the enquiry. The results are analysed in terms of explanations and the implications of the work are best realised in terms of its implications to inform decisions about basic issues underlying curriculum development of STS materials.

	CHILDREN'S ALTERNATIVE CONCEPTIONS	PUBLIC UNDERSTANDING OF SCIENCE	SCIENCE, TECHNOLOGY AND SOCIETY	MENTAL MODELS	COGNITIVE PSYCHOLOGY
REFERENCE	<p>Science } - selection of topics for enquiry - framework for analysis</p> <p>Commonsense: an alternative body of knowledge considered in its own right</p>	<p>Science } - selection of topics + Technology } - framework for analysis</p> <p>relevance for society</p>	<p>Social Relations of Science and Technology</p>	<p>Models in Scientific Thinking</p>	<p>- Knowledge - Memory - Perception - Attention - etc</p>
CONTEXT	Planned Instruction	Incidental Learning	Planned Instruction	Research on Cognitive Science, Artificial Intelligence, Computer-Aided Learning.	Research on Psychology
STATUS	<ul style="list-style-type: none"> <li>- errors</li> <li>- misconceptions</li> <li>- prior -to-teaching ideas</li> <li>- alternative conceptions</li> <li>- alternative frameworks</li> </ul>	<ul style="list-style-type: none"> <li>- "correctness" (right or wrong)</li> <li>- relevance</li> </ul>	<p>Individual Possession of Abilities</p> <ul style="list-style-type: none"> <li>- awareness</li> <li>- criticism</li> <li>- argumentation</li> </ul>	<p>Use of Models in Thinking</p>	<ul style="list-style-type: none"> <li>- interactions</li> <li>- constructions</li> <li>- behaviours</li> </ul>
FOCUS	<ul style="list-style-type: none"> <li>- Content of Ideas</li> <li>- Forms of Explaining</li> </ul>	<ul style="list-style-type: none"> <li>- Level of "informedness" (as measured by the amount of information possessed).</li> <li>- Specific "bits" of knowledge held.</li> </ul>	<ul style="list-style-type: none"> <li>- Information</li> <li>- Judgements</li> <li>- Controversy</li> </ul>	<p>Entities Mechanisms Processes Analogies } Mapping between Domains</p>	<p>Learning</p> <ul style="list-style-type: none"> <li>- Observation</li> <li>- (Clinical) Interviews</li> <li>- Psychological Tests</li> </ul>
METHODOLOGY	<ul style="list-style-type: none"> <li>- Paper and Pencil Tasks (Questionnaires)</li> <li>- Interviews } clinical about instances etc</li> <li>- Classroom Observational Studies</li> </ul>	<ul style="list-style-type: none"> <li>- Public Opinion Surveys (questionnaires and/or face-to-face interviews)</li> <li>- Media Studies</li> <li>- Evaluation of Informal Learning (museums, etc)</li> </ul>	<p>Recorded group discussion in the classroom</p>	<p>Problem solving tasks using computer simulation or modelling software.</p>	
ANALYSIS	<ul style="list-style-type: none"> <li>- Fragmented</li> <li>- Structured</li> </ul>	<ul style="list-style-type: none"> <li>- Decontextualised } amount of fragments</li> <li>- Contextualised } used/needed contrasted to other knowledge or to other needs</li> </ul>	<ul style="list-style-type: none"> <li>- Discursive Skills</li> <li>- Knowledge</li> </ul>	<ul style="list-style-type: none"> <li>- Fragmented Theories</li> <li>- Novice Expert</li> </ul>	<ul style="list-style-type: none"> <li>- Nature of Knowledge</li> <li>- Role of "Knower"</li> </ul>
IMPLICATIONS	<ul style="list-style-type: none"> <li>- Learning</li> <li>- Teaching</li> <li>- Cognition</li> </ul>	<ul style="list-style-type: none"> <li>- Scientific Literacy</li> <li>- Decision Making</li> </ul>	<ul style="list-style-type: none"> <li>- Decision Making</li> </ul>	<ul style="list-style-type: none"> <li>- Machine Learning</li> <li>- Human Learning</li> <li>- Cognition</li> </ul>	<p>Learning</p>

Table 3.3: An Analysis of Different Contexts of Enquiry for Peoples Ideas in Science

---

---

## CHAPTER IV

### ON COMMUNICATING SCIENTIFIC IDEAS

---

---

#### **4.1 INTRODUCTION**

This chapter discusses some aspects of how scientific information, in particular that about radioactivity related matters, is communicated to the general public by the press. As a proper discussion of this topic would justify a whole piece of research on its own, it is essential that the objectives and limitations of this discussion are made clear from start. The purpose of such discussion is twofold. Firstly, and because many of the articles analysed were published in connection with the accident at Goiânia, they provide specific information about the kinds of news the informants of this research were likely to have had contact with at the time of the accident at Goiânia. Secondly, and at a more general level, it attempts to illustrate and exemplify some problems related to the communication of scientific ideas to the lay person. It does not contain an exhaustive analysis of the available material but, rather, a selection is made of newspaper and magazine articles, extracts from both scientific popularization and school text books, published in Brazil and in the UK, the analysis of which explores the issues described above. Appendix 4.1 contains a list of materials analysed.

#### **4.2 A CHARACTERISATION OF THE MATERIAL ANALYSED**

Written materials from different sources were analysed. Many of them are actual newspaper articles published in connection with accidents involving radioactive materials, in particular, the accident at Goiânia. They come mainly from quality news papers or weekly magazines and reflect, to some extent, the broad picture of how the subject was treated by the press at that time, containing factual information, details about the events and, less often, interviews with experts on nuclear energy.

Another substantial fraction of such written materials come from scientific popularisation magazines. Again, some were published in connection with accidents involving radioactive materials though most of them take a wider perspective. They are, in general, written by experts (nuclear physicists).

A third kind of material which contained radioactivity related information is that in the form of explanatory texts published by Atomic Energy Agencies, as leaflets distributed free to whoever requests them. These are also written by experts and have limited circulation.

According to results found both in the current literature and in the present study, most of the information students possess about radioactivity related matters is acquired incidentally and not systematically, and primarily through TV (see chapter 3 and chapter 6). It was impractical to attempt to analyse TV programmes, since it would have been difficult and time-consuming to obtain tapes of them. So the present analysis is restricted to written materials. Although not the most frequent source of information for people, they should reflect some important aspect of the communication of scientific information.

Overall, 56 texts were analysed. Table 4.1 shows the number of each specific type of text.

TYPE OF TEXT	NUMBER
Newspaper articles	23
Explanatory Leaflets	9
Scientific Popularisation Magazine Articles	13
Weekly Magazines	5
Teacher Support Material	6

Table 4.1: A Classification of the Written Materials Analysed.

From the twenty-three newspaper articles analysed, twenty had been published in connection with the accident at Goiânia and three concerned general aspects of the topic. All the five articles from weekly magazines had also been related to the accident, and from the thirteen scientific popularisation magazine articles, seven mentioned either Goiânia or Chernobyl. Teacher support material analysed was very diverse and consisted of one book, two articles and three samples of STS teaching materials.



### 4.3 THE ANALYSIS OF THE MATERIAL

#### 4.3.1 A MODEL FOR TEXT ANALYSIS

A model was devised to help analyse the different texts, which takes account of interaction between two cognitive entities: the reader and the text.

Relevant features of such an interactive model which apply for both reader and text are: *purpose*, *focus*, *presuppositions* and *context*. Such features are not all at the same level. *Purpose* has to do with attitudes and motivations of both reader and writer. *Focus* relates mainly to the actual content of the information given. *Presuppositions* concern assumptions made about the relationships between the two cognitive entities and the subject matter itself. Finally, *context* is about the identification of particular characteristics of a given situation which intervene in both the conception of the text and its understandability.

The first feature, *purpose*, relates to, on the one hand, the motives which led the reader to actually read that particular piece of information and, on the other hand, to the objectives according to which the text was written. People may be inclined to read such kind of information with different intentions, that is, with any aim, from mere general knowledge curiosity to a specific need. Similarly the text might well have been written for any purpose from merely providing factual information about an event to developing an elaborate type explanation of the same event with a specialised purpose, for example to teach somebody or to persuade someone towards a given point of view. Purposes can also be regarded as internal or external, depending on the nature of both readers' and writers' motives. For example, somebody may need a given piece of text to resolve a personal puzzlement or as part of the requirements of a study programme. Similarly some scientists may be inclined to write because they think it is important to provide accounts of scientific facts which are accessible to the general public.

The second feature, *focus*, concerns "What is actually said". It relates to the actual content of the message conveyed as well as to the aspects which have been prioritised. For example, the discovery of radioactivity may be treated as an instance of scientific practice, applications of radioactivity in industry or in power production can be said to exemplify its wide-range of technological applications, etc. Ultimately this involves a discussion of the nature of the physical entities and

processes which appear to be at work. An analysis concerning focus concentrates on the description of and explanations for radioactivity phenomena, discussing them in terms of entities and events which are mentioned, and their conceptual relationships.

The third feature, *presuppositions*, relates to the kind of prior knowledge both readers and writers may have and that may influence their understanding of the information contained in the text. It concerns not only specific knowledge of factual information but also knowledge of related aspects and background knowledge of science in general.

The fourth feature, *context*, concerns information related to knowledge which is specific to different contexts and that may influence the process of understanding of the text. Depending on context, people may feel a greater or lesser pressure to understand something. The degree to which some aspects of information may be regarded as problematic also depends on context. For instance, the hardness of solids is unproblematic in everyday life context but involves deeper questions about the structure of matter in the contexts of learning basic physics. Similarly, the level of commitment to making sense of a piece of written information varies considerably whether it occurs at school or at home.

#### 4.3.2 NEWSPAPER AND MAGAZINE ARTICLES

Texts found in newspapers tended either to be designed so as to provide factual information about radioactivity related events or, less frequently, to present information about applications of radioactivity in daily life.

In the first kind of article the focus was the actual event though the texts could also contain some explanatory information about radioactivity in a more incidental way. Therefore texts of such a type are more likely to contain descriptions or reports of facts which happened in real life, with a faithful and complete account of the event being their primary concern. Many of the texts which were published at the time of the accident of Goiânia were of this type. The prevalence of articles of this kind is, then, to be understood not only in terms of fulfilling a natural function of newspapers, but because the real circumstances in which the Caesium capsule had been opened remained unclear for a some time, which led to a great deal of

speculation about both the causes and the potential consequences of the accident. As the proportions of the tragedy became more evident, newspaper articles included some explanatory information about ionising radiation, its nature and properties, its effects on living tissue, the dangers of contamination, etc. In some cases, this information was obtained in interviews with experts who answered questions concerning future prospects both for people who were involved in the accident and for the place where it had happened. Among the questions asked were “ What happened at Goiânia ?”, “Why did a small amount of Caesium cause such contamination ?”, “What is radioactivity ?”, “What are the symptoms and sequels of exposure to radioactivity ?”, “What is the difference between radioactivity in Chernobyl and Goiânia ?”, etc.

Articles which did not necessarily have a direct connection with the accident started to be published later, perhaps, as a result of a wider familiarisation of the general public with matters concerning radioactivity after their interaction with information related to the accident at Goiânia. By contrast with the immediate coverage of the accident, these articles were not front page news but were normally published in the science and technology sections of quality papers, which suggests that they were directed to a more selected audience, namely readers with a stronger or more specific interest in the subject.

At the level of presuppositions, assumptions about the reader are: degree of prior knowledge on the subject, ability to reason in more abstract terms, level of familiarisation with technological applications. Some texts found in newspapers are conceived according to a minimum expectancy under any of these headings. They tend to make wide use of examples and comparisons with situations which are familiar to the lay person as well as emphasising the applications of ionising radiation more strongly than its related theoretical aspects. Examples of such comparisons are:

*“... A leaflet published by the International Atomic Energy Agency, in Vienna, Austria, compares radioactivity to whiskey. The effect depends on the dose. A small measure of whiskey may not have any effect, but a whole bottle may “knock somebody out. As in the case of the spirit, not only does the effect of radiation depend on the dose, but it also depends on how long the person was exposed to it. “ ....*

*During an eight-hour airplane flight, a person receives a dose of radiation of four milirem, which come from the stratospheric cosmic rays. By comparison, a person who lives by a nuclear power station receives one milirem per year (provided the station does not explode). Thus, it is*

*possible to conclude that a Rio-New York flight is equivalent to to living by a nuclear power station for five years." (Jornal do Brasil, 18.02.90)*

*"Like the beam of a flashlight, radiation decreases as one gets far from the generating source..." (Veja, 14.10.87)*

As the text becomes less superficial, it increasingly makes reference to basic physical concepts or some use of scientific jargon, as shown by the example below where the discovery of a mineral that is able to "catch" Caesium is reported. The example below is also an instance of how misleading and obscure such information can be.

*"Scientists manufactured the trap-substance to catch Caesium, altering a type of mica found in Perth, a province of Ontario, Canada. They have rubbed it with emery till it was reduced to a small particle, later it was treated so as to have positive charged atoms of Potassium and insert a layer of molecules of Sodium and water between the layers of mica". (Jornal do Brasil, 12.03.88)*

This is especially true of a discussion of the different units used to measure absorbed dose, activity of a source or to explain the notion of decay and half-life. With few exceptions, units are not properly defined or employed, as in the example below.

*"In order to measure the damage which a radioactive source may cause in the human being, scientists created the units of absorption of radiation - which vary depending on the time of exposure and on the irradiating power. In the case of Caesium 137, responsible for what happened in Goiânia, the most utilized unit is the REM." (Veja, 14.10.87)*

As will be seen in Chapter 10, this latter point is regarded by teachers as critical as far as both students' and lay people's understandings of explanations about radioactivity is concerned.

Very often, comparisons were made between accidents involving radioactive material though previous information about neither of the events under question was taken for granted. Such comparisons in general emphasised that in Chernobyl contamination was caused by a greater amount of radioactive gas and particles of radioactive elements such as Caesium, Strontium, etc, whereas in Goiânia the radioactive material spread itself as dust. The proportions of the two disasters were also compared in terms of the number of victims. Comparisons about the two accidents sometimes suggested a confusion between the units used to measure dosage and the radioactive materials themselves. For example, "*Becquerels from*

*Goiânia are the same Becquerels from Chernobyl"* (Correio Braziliense, 29.09.91).

The contexts in which people are likely to come across this type of information are mostly related to a need to acquire some information about important everyday matters. For this reason, the text is written in a way aimed at a wider though superficial level of immediate general awareness. This imposes a condition that information should be potentially easily assimilated by readers, a fact reflected in unsophisticated arguments and abundance of factual information.

#### 4.3.3 SCIENTIFIC POPULARISATION MAGAZINES

Scientific popularisation magazines are, in general, published with the main purpose of presenting scientific activity and its achievements to the general public in a way that is basically accessible and correct. This characterises a distinct enterprise from merely presenting factual information and implies certain constraints on both *what is said* and *how it is said*.

Most of the material from Brazilian scientific popularisation magazines analysed was originally published as responses to actual questions asked by readers. This coincidence enables us to digress for a moment and to identify kinds of questions asked in connection with ionising radiation by the average reader of such a magazine. Many of these questions concern x-rays (more specifically, the acceptably safe limits of exposure in the case of dental x-rays), how an x-ray device works, the reason why different tones of grey appear in a x-ray plate or whether radiation could spread through the body of a person who had an x-ray taken of a small part of the body. Other questions concern the existence of areas where there is a "high level of environmental radiation" and the risks the population who live in such areas would suffer. There were also questions asking for an account of what had happened at Chernobyl and the consequences of that accident for the people who live in the surroundings of the power station.

Responses were given by experts on nuclear energy or Biophysics, and tend to be comprehensive and detailed. There are explanations of the nature of ionising radiation and special attention is paid to characterising electromagnetic waves in

terms of magnitudes such as frequency, wavelength and energy. Although some reference is made to physical concepts like, for example, the photon, references like these are not usually followed up. Such explanations are also likely to appear even when the questions do not directly ask for a scientific explanation of the nature of radiation. The response given to the question *What is an x-ray?* and part of that given to the question *What actually happened in Chernobyl?* are quoted below as examples.

***"What is an x-ray?"***

*X-rays are electromagnetic radiations. Electromagnetic radiations include the gamma rays, x-rays, ultraviolet rays, the visible light, the infrared rays and the radio waves. All these radiations are of the same nature, that is, they are electromagnetic oscillations which propagate and follow a sinusoidal oscillation. ... Four magnitudes characterise an electromagnetic radiation: the frequency (number of oscillations per second of the magnetic field associated to radiation), the period (time of each oscillation, measured in seconds), wavelength (distance travelled by the oscillating phenomenon during one period) and energy (energetic value of radiation photons). Photons are the particles which constitute the radiation beam. The velocity of propagation of the electromagnetic radiations (the so-called speed of light) is circa 300,000 Km per second in the vacuum." (Ciência Hoje, Vol.2, No.: 12, may-june/1984)*

*"... It is also worth clarifying that the term radiation will be used here to designate the ionising radiation -, that is, that which is able to produce ions as it passes through matter. Examples of radiation are alpha and beta particles, x and gamma rays and neutrons. ..." (Ciência Hoje, Vol.4, No.: 24, may-june/1986)*

There were also pieces which were published as regular articles. Two of them, following the accident at Chernobyl, concerned the question of food (milk and meat) imported from Europe which was found to be contaminated by the radionuclides Caesium 134 and Caesium 137. These articles contained both a discussion of the measurement of the activity of radionuclides and a discussion of the actual question of decision making, as far as the cost/benefit relationship of the distribution of the food was concerned. They contain a succinct but very clear explanation of radioactive decay and half-life, which, however, takes for granted an understanding of concepts such as isotopes and disintegration. As they are written with a particular audience in mind, articles from scientific popularisation magazines tend to rely more heavily on some kind of previous knowledge though, in some cases, explanations of fundamental concepts are also given on the course of the explanation, by contrast with newspapers, which tend to avoid mentioning them. This point is illustrated by the quotation below.

*" ... The unit Becquerel (Bq) measures the activity of radionuclides (radioactive atomic nuclei) through their number of disintegrations per second: one Becquerel is equal to one disintegration per second. ... As they emit radiation, the radionuclides disintegrate, transforming, in general, into isotopes of other chemical elements, which are radioactive too. The time necessary for the initial amount of a radionuclide to halve."*  
(Ciência Hoje, Vol.5, No.: 28, jan-feb/1987)

Some algebraic manipulation so as to calculate the maximum limits of consumption for such products considering their maximum level of radioactivity, may also be often found though its understanding may not be at all straightforward considering the difficulties with Mathematics some students stated that they have (Chapter 9). The passage quoted below explains how the limits for the radioactivity of the milk imported from Ireland were calculated. The article discusses criteria adopted by the European Economic Community to adopt the maximum level of 370 Becquerels of Caesium 137 per each kilogram of milk powder.

*" Answering to a request from the Rio de Janeiro Protection of the Consumer Association, in 1 December 1986, the scientist Anselmo Paschoa (Department of Physics of the Pontificia Universidade Católica / RJ) .... explained that this limit derives from the so-called Annual Limmit for Ingestion (ALI), stipulated by the International Commission of Radiological Protection (ICRP). The ALI represents the activity of a nuclide which, if considered isolated, would irradiate one adult in one year time. In the case of Caesium 137, this value is 4 x 10 Bq. In the case of children, this value is divided by 100, giving 4 x 10. Considering a daily consumption of 300 g (0,300 Kg) of milk powder during the 365 days of the year, it is possible to calculate (0,300 Kg/day) x (365 days/year)= 109.5 Kg/year as being the total amount of milk powder consumed during this time span, that is:*

$$\frac{4 \times 10 \text{ Bq Cs } 137/\text{year}}{109.5 \text{ Kg/year}} \approx 370 \frac{\text{Bq Cs } 137}{\text{Kg}}$$

(Ciência Hoje, Vol.5, No.: 28, jan-feb/1987)"

As will be seen later, in Chapters 9 and 10, such definitions, especially when accompanied by numerical examples, are found to be difficult for students. Such articles may also present figures comparing, for instance, rates of exposure to external levels of radiation and absorbed dose, or the half-lives of different radionuclides. In fact, such comparisons were found to be frequently made, though scientific popularisation magazines present and display data in a different way from newspapers, making a greater use of graphs, tables and diagrams.

Similar articles were found in scientific popularisation magazines and journals in the UK. Articles published in the UK tend to concentrate more on discussion about consequences of applications of radioactivity in industry, for example, food

irradiation, rather than on the presentation of scientific information. Explicit references to science as well as use of jargon are less frequent. Another difference is that arguments are presented as a kind of polarised debate between experts. In a sense, this can be seen as a process in which the impossibility for the lay person to question the expert's opinion is reinforced.

#### 4.3.4 EXPLANATORY LEAFLETS

This kind of material is normally designed and published by Information Services from Atomic Energy Authorities emphasising the effects of ionising radiation on people and issues concerning the safe utilisation of radioactive materials. Most of the material analysed was published in the United Kingdom by the UKAEA (United Kingdom Atomic Energy Agency). The UKAEA has issued several such publications, such as: *Radiation and You*, *Nuclear Fusion*, *Nuclear Waste*, *Atoms at work*, *Energy and the Need for Nuclear Power* and *The effects and control of radiation* as well as a *Glossary of Atomic Terms*. All these materials are distributed free on request.

Although the presentation of leaflets may differ, with some being more comprehensive than others, the texts are basically structured in the same way. Nearly all of them start with an introduction context of applications. Some background scientific information is often given mainly concerning the nature of radiation and the different types of ionising radiation. Concepts such as radioactive decay, half-life, different sources of radiation, etc, are presented with much use of graphical displays. Biological effects, risk estimates and a discussion of safety and control are also frequent. The main theme of the text is then introduced as a balanced discussion well grounded in factual information and, often, some statistics.

These texts appear to be written so as to present ordinary people with a balanced picture of benefits and shortcomings of different uses of ionising radiation. Nonetheless, it is possible to raise the question of whether they in fact convey a biased view of the problem, since issues related to the safety controversy tend to be argued mainly by the presentation of evidence of the predictability and control of ionising radiation use and effects. This point is illustrated by the summary section of the leaflet *The Effects and Control of Radiation*, published by the UKAEA.



*" The effects of ionising radiation have been extensively studied and are better understood than those of practically all other harmful agents.*

*The nuclear industry is a very minor contributor to total radiation, most of which comes from natural background and from medical uses.*

*Nuclear power in Britain has an outstanding safety record and the industry is among the safest in the country.*

*Nuclear electricity generation involves no more and probably less overall risk than coal or oil fired electricity generation.*

*Radiation can be used beneficially in medicine and in many manufacturing industry."*

Another source of information of this type can be found in the form of reports which are aimed at clarifying general public doubts about certain applications of ionising radiation in industry, in areas which give rise to contentious debates like, for example, food irradiation. The debate tends to be polarised with opposing views being made explicit and challenged. There are explicit reference to science and to scientific expert opinions in both cases. Arguments against food irradiation tend to be grounded on a more critical analysis of facts and relativisation of expert opinions, whereas arguments for it are more likely to present a collection of facts supported by some statistics and quotes of expert opinions. This is illustrated by the quotations below.

*"There are many unsolved safety questions that should be answered before irradiation is permitted. The apparent display of scientific arrogance by 'experts' is a characteristic that has been observed in the past. There are lessons to be learnt from asbestos, thalidomide and many suspect food additives which were declared safe in their day. Food irradiation is another case of the public being asked to put faith in one school of 'expert' opinion and to assume that something is safe."* (Irradiation: The Contamination of Food, Friends of the Earth, 1989)

*"Food irradiation is to be allowed in Britain, but its use will be strictly controlled and all goods treated will have to be clearly labelled, the Rt Hon John MacGregor MP, Minister of Agriculture, Fisheries and Food, announced today. Mr MacGregor told the House of Commons that: -world health experts (including the World Health Organisation) are satisfied that food irradiation is safe; - food irradiation is permitted in 35 countries including the USA and France; - food irradiation is already used in the UK for treatment of food for some hospital patients with very severe illness; - its use will help to reduce the risk of food poisoning; - irradiation does not affect the wholesomeness of food; - all irradiated food will be clearly labelled, so that consumers decide whether or not to buy it."* (MAFF, News Release, 21 June 1989)

#### 4.3.5 TEACHERS' SUPPORT MATERIAL

Examples of teacher's support material analysed included scientific explanations about ionising radiation accompanied by a discussion of some of its applications and uses. In Brazil, since radioactivity is not part of the secondary school programme, materials of this kind are more likely to be found in school science oriented journals than in, for example, teachers' guides to science text books. The main preoccupation may be with the correctness and intelligibility of information presented with a discussion of the implications of using ionising radiation for society not being a major issue. An alternative approach is to start the discussion by an analysis of a radioactivity related issues with clear implications for society and in relation to which scientific information is to be discussed. The main concern is the social implications of scientific knowledge.

Thus, articles identified with the first approach might contain a detailed description of an atomic model for matter, presenting radioactive disintegration as a spontaneous process for unstable nuclei, describing the several mechanisms of disintegration as well as of the several types of radiation, nuclear fission, nuclear fusion, etc. Articles of the second type would concentrate in the analysis of the applications of ionising radiation in society, focusing the discussion on issues of concern as, for example, nuclear waste storage and disposal, and deriving a discussion of the relevant scientific information necessary to understand the discussion, for example of the half-life concept.

Radioactivity was also found to be one of the most frequently mentioned topics in didactic materials within a STS approach. All the examples analysed were designed so as to be used in conjunction with related materials so as to complement the regular science curriculum at secondary school. Materials like SATIS (Science and Technology in Society) start with an analysis at the level of consequences, implications and effects of several applications of radioactivity which is followed by a discussion of the relevant related knowledge, not only in physics but in other disciplines too. The main aspects discussed include knowledge of applications, assessment of risks and informed decision making. Guidance is given so as to stimulate the teacher to encourage other forms of classroom activities, such as role-play and structured discussions. There is explicit advice in so far as aspects such as timing, suggested teaching approach, links with syllabus and relevance of each unit to topics and skills both in STS and Science are concerned. Other series such

SISCON (Science in a Social Context) and 'The Nature of Science' provide a historical account of the development of technologies associated with radioactivity, such as nuclear power stations and nuclear bombs, situating scientific discoveries in their socio political context.

Materials from Brazil would be better identified as examples of an approach which starts from relevant knowledge in science and discusses effects and consequences of radioactivity as implications and examples of applications in everyday life. The two articles and the book analysed illustrate attempts to provide the teacher with reliable information compiled so as to cover basic knowledge necessary for a scientific explanation. Although a great deal of reference to applications of radioactivity and its implications for society is made, it is the discussion of the relevant scientific knowledge that is the object of major concern.

#### **4.4 SUMMARY: A General View of the Material Analysed**

Characteristics of the different materials analysed were found to differ and to vary in depth, in the structure of the presentation and in lines of approach.

There seems to be a general tendency to "substantialise" radiation. In a microscopic approach, radioactivity is characterised as a property that unstable nuclei have of emitting either particles or electromagnetic radiation. In order to do that, it is necessary to evoke a model for the atomic structure of matter. This is usually not, however, pursued thoroughly and the discussion focus on characterisation of different kinds of ionising radiations. Radiations are then characterised through the relative comparison of some of their physical magnitudes such as mass and velocity. Similarly, their power of penetration is usually derived from associations with their linear momentum so as to explain that light particles will travel faster than the heavier ones, with those which possess the greater power of penetrating being weightless.

This attempt to 'substantialise' radiation is very common in popularised accounts and reflects a tendency to make the intangible less remote and intelligible. However, the intended correct conceptualisation may be impaired, as the nature of the entities employed to refer to ionising radiation changes abruptly in accounts like the one

shown next, where knowledge of the equivalence mass/energy is almost taken for granted.

*"What is radiation?"*

*All matter is made up of atoms, most of which are stable and never change. However some atoms are unstable and can change into another form. As they do so, these 'radioactive' atoms send out or radiate energy as particles or rays...."* (Radiation and You, UKAEA, 1988)

In a microscopic approach this tendency to substantialise radiation is made through direct comparisons of radioactive materials with concrete substances such as dust, gas, stone, etc. Another important common point across texts, be they teacher support material or designed for a lay audience, is that there are references to school science. The quotation below illustrates this point as it appeals to previous familiarity with some chemical elements and some of its properties.

*"... The major variation in background radiation is due to differences in amount of natural radioactive elements - such as Uranium, Thorium, Radium and other - in rocks and in the soil..."* (Radiação Ambiental na Região de Poços de Caldas, Ciência Hoje, 1983, 1, No.4, pp.79)

In fact, most of the texts analysed, even those written for a lay audience presupposed some kind of familiarity with basic concepts of atomic structure of matter and also an ability with calculations of rates and proportions. This happened to be a criticism students themselves made of a written text they were asked to read and discuss as part of the data collection (see chapter 9). It has also implications at the level of the necessary re-constructions and re-translations that have to be made in order to make scientific explanations intelligible to a wider audience, outside the boundaries of the scientific community.

#### **4.5 LAY MODELS OF RADIATION**

It was also possible to identify in many of the articles analysed ideas which are similar to those reported in studies by Eijkelhof (Eijkelhof, 1990) and Eijkelhof & Millar (Eijkelhof & Millar, 1988) derived from an analysis of newspaper articles published in connection with the Chernobyl accident (see chapter 3). Surveys carried out in the UK and in the Netherlands show that there seems to be a consistent pattern of misconceptions related to ionising radiation that are present in the accounts of non-experts. The lay model of radiation would be characterised by: the undifferentiation of the ideas of radiation and radioactive material; the use of the

word radioactivity as a 'catch all' term; confusion about different units of measure; the view that radiation/radioactivity have a definitive life-time. It was possible to observe such features in most of the materials analysed. In fact the tendency to "substantialise" radiation is itself an aspect of the undifferentiation of concepts. Confusion about different units of measurement, such as confusion between the unit used to measure the activity of unstable nuclei (Becquerel and Curie) and the unit of absorbed dose (Rem, Gray or Sievert), confuses substance and activity.

#### 4.6 ON EXPLAINING AN EXPLANATION

Explanatory accounts of ionising radiation as found in the press illustrate the well-known problem of communication of scientific knowledge outside the boundaries of the scientific community. Studies inspired by this concern date as early as the late fifties (Flood, 1957) when the formulation of the problem of communicating science to the lay person in terms of the growing need for better knowledge in face of scientific development was first put forward. In Flood's view, illustrated by the quotation below, the essential problem of communicating science to a lay audience rests ultimately on the kind of language used in scientific accounts.

*" It is strange that, in spite of the importance of popular science, little study seems to have been made of the techniques of presenting it. The exposition of material in a popular form, especially to adults, is very different from the teaching of it to students in a classroom. Many ordinary people feel that science is beyond them, that the gap cannot be bridged, but this need not be so. The solution can be found in a more extensive study of the techniques of exposition. ... From the many problems for research, one, the problem of vocabulary, has been chosen for study... Can we present science to the ordinary man in words he understands? What words are essential for the presentation of popular science? Do ordinary people know these words?..." (Flood, 1957, p.3 and p.4)*

If one considers the issue in a broader perspective these seems to be a case for examining the problem of the communication of scientific ideas in relation to the dimensions proposed in section 2.2. This broader perspective involves the features purpose, focus, presuppositions and context, discussing them in relation to the difficulties from:

- \* particular motives/grounds/cases for popularising science.
- \* the "amount" and the "depth" of the content to be treated as well as the forms in which to present it.

- \* the ways learning is considered to occur and the relevance of prior knowledge in interpreting new information.
- \* the implicit authority an argument may acquire depending on the context it is presented.

The most important point is that a popularised account of science consists basically in an explanation of another explanation. Scientific explanations, as intelligible and suitable within academic discourse, have to be re-explained so that a lay audience is able to make sense of them.

#### 4.7 CONCLUSIONS

This analysis of how the press deals with the topic of ionising radiation served two main purposes. First it enabled a characterisation of the possible kinds of material the informants of this research might have had access to. Secondly it helped raise issues related to the communication of scientific ideas to a lay audience.

Information given is strongly contextualised, with explicit references to situations and events of real life where radioactivity and/or some of its effects and consequences happen to be important. Examples of these are, accidents involving radioactive material, problems related to storage and disposal of nuclear waste, discussions concerning the functioning of nuclear power stations, and so on. Only very rarely is the topic presented on a purely general informative basis.

As far as explaining radioactivity to lay people goes, issues that appeared to be problematic were, amongst others: the reference to models and analogies in explanations, the need to refer to some kind of previous knowledge of science, the use of quantitative arguments in explanation.

Finally, the analysis also provided a basis for defining criteria to choose written material to be used with students, at a later stage, in the data collection for the main study (see chapter 5).

---

---

## CHAPTER V

### CHOICES, DECISIONS, CONSTRAINTS AND PRACTICALITIES

---

---

#### **5.1 INTRODUCTION**

The main objective of this research is to investigate people's perceptions and understandings of scientific information related to matters of public importance. To address the primary concern of discussing these perceptions and understandings in the context of the communication of scientific ideas and educational implications, it was decided to select groups the members of which possess a definitive commitment with learning, namely, students and teachers.

#### **5.2 HOW CAN WE ASK PEOPLE ABOUT WHAT THEY DO NOT KNOW?**

Having decided to investigate what people's knowledge and perceptions about scientific information with public importance are, one immediate problem arises: the contexts in which science most commonly appears in everyday life may involve the most unfamiliar entities and elaborate theories. Studies conducted within the traditional approach to the investigation of the public understanding of science (see section 5.3) reveal that a significant number of people, in general, lack knowledge of basic science. However, in this work the most useful piece of information remains missing, if one is to discuss the relationships between scientific knowledge and society as a whole. For when speaking about scientific literacy, it is people's competence in making sense of information they are likely to come across with that matters, rather than their present state of ignorance.

The dilemma is then by-passed by emphasising that people's actual knowledge is important to the extent to which it is relevant for the construction of the understandings of scientific information. These aspects are: the contexts in which information was acquired, an evaluation of the intelligibility of such information, how one sees oneself in relation to scientific knowledge, all seen as influencing and shaping understanding of new related information. Thus, information about people's prior contact with the specific scientific knowledge necessary to understand the events such as the greenhouse effect, HIV infection, etc, is regarded as not being important as an assessment of how far people's ideas are from a correct scientific conceptualisation, but in the context of a discussion of how this prior knowledge may affect subsequent learning.

### **5.3 CONTENT-FREE OR CONTENT-SPECIFIC ENQUIRIES**

Some work on people's opinions of science tries to achieve a general context-free collection of views. This is addressed by framing the enquiry in a way that avoids having people identify the questions asked with a particular context, event or situation. The expected outcome is a collection of answers which express views applicable to a wide range of instances. However, some of the questions, especially by not being grounded in any particular context, may seem to the subject to be vague or imprecisely formulated. Take the example of the questions below, used by Zoller et al (Zoller et al, 1991) in a study conducted on Canadian students' versus teachers' beliefs and positions on science/technology/society oriented issues. Both questions were extracted from the VOSTS (Views On Science-Technology-Society) inventory form CDN.mc.4 (Aikenhead, 1987) an item pool used as an instrument that assesses student learning in STS courses or teaching programmes.

*2. Canadian scientists should be held responsible for the harm they might result from their discoveries.*

*Your position, basically: (Please choose one)*

*A. Scientists should be held responsible because they must be aware of the effects of their experiments ahead of time. Science should cause more good than harm.*

*B. The responsibility should be shared about equally between the scientists and the society.*

*C. Scientists should not be held responsible because it is people who use the discoveries who are responsible. Scientists may be concerned, but they have no level of control over how others use their discovery.*

*D. None of these choices fits my basic viewpoint.*



4. *In order to improve the standard of living in Canada, it should be better to invest money in technological research rather than scientific research.*

*Your position, basically: (Please choose one)*

A. *Invest in technological research because it will improve production, economic growth, and employment. These are far more important than anything that scientific research has to offer.*

B. *Invest in both because there is really no difference between science and technology.*

C. *Invest in both because each in its own way brings advantages to society. For example, science brings medical and environmental advances, while technology brings improved conveniences and efficiency.*

D. *Invest in scientific research - that is medical or environmental research - because these are more important than making better appliances, computers or other products of technological research.*

E. *Invest in neither. The quality of living will not improve with advances in science and technology, but will improve with investments in other sectors of society (e.g. social welfare, education, job creation programmes, the fine arts, foreign aid, etc).*

F. *I don't know enough about this subject to make a choice.*

Such questions present difficulties of readability, interpretation and discrimination between the options. One response does not represent essentially one idea. Because of the complexity of the ideas involved in the statements, as for instance, in question 4 where several issues are involved, namely (support for) policies for research and development, differences between science and technology and the relationships between results of research in both scientific and technological research in so far as the improvement of the quality of living is concerned, the issue is obscure. Because subjects may agree only partially with some of the alternatives presented as they include, in general, more than one single idea usually in the form of an assertion and its corresponding justification, a clear response may be impossible. Lastly, there is no reason to think that answers would be the same if the questions were asked in the context of different specific examples. As an example, consider two distinct situations, both representing substantial technological achievements derived from scientific discoveries, namely kidney transplants and microwave ovens. The question about responsibilities for the uses and consequences of scientific discoveries might yield two different kinds of response if considered against these two backgrounds, as the possibilities for personal decision are much more limited, if not entirely precluded, in the case of being given medical advice. In fact, in the first case the decision rests almost entirely in the hands of the specialist whereas, in the second case the decision to buy a microwave oven is ultimately made by the individual. Therefore, the responsibility for the "use" and consequent effects of different technologies differs, depending on the degree of access different sectors of society may have to decision-

making, which is itself dependent on the level of expertise necessary to make such decision considering its potential consequences. It is this last point which calls for reflection on the possible advantages of framing the enquiry around a specific scientific/technological fact or event. By providing some context to the discussion of issues related to the implications of science and technology for society it is hoped to get answers which are both more reliable and valid, even though now restricted to this context.

#### **5.4 THE POSITION TO BE ADOPTED**

The topic of radioactivity was chosen in preference to other topics (such as the greenhouse effect, HIV infection, etc) because of its wide range of applications in technology and its importance as a piece of fundamental science. One reason for its choice was the fact that an unfortunate accident involving radioactive material in 1987 in Brazil was the object of extensive coverage by the media, which guaranteed that, in one way or another, people would have had some degree of interaction with information about the topic. Another reason is that explicit reference to a real event would help address the question of people potential's capability of understanding scientific knowledge necessary to make sense of events in daily life.

The choice of a semi-retrospective line of enquiry may, however, be seen as problematic in that one may doubt to what extent inferences may be based upon people's recollections. Evidence from studies conducted by experimental psychologists on the limitations of the human memory support the thesis that people readily forget information though the rate of "forgetting" may depend on the nature of the information under question. Nonetheless, the view that memory is a reconstructive process, and that things and events are interpreted against a personal background of beliefs and assumptions, so that what people usually recall is their own interpretation of facts instead of actual observations has been substantiated since it was first put forward by Bartlett (Bartlett, 1932).

It is possible to find instances of this idea, namely that what people remember is dependent on their perceptions, beliefs and comprehension, in references from different disciplines. For example, Berger & Luckman (Berger & Luckman, 1966)

talk about *sedimentation* and discuss the importance of shared experiences which form the basis for common knowledge:

*"Only a small part of the totality of human experiences is retained in consciousness. The experiences that are so retained become sedimented, that is, they congeal in recollection as recognizable and memorable entities. Unless such sedimentation took place the individual could not make sense of his biography. Intersubjective sedimentation also takes place when several individuals share a common biography, experiences of which become incorporated in a common stock of knowledge."* (Berger & Luckman, 1966, p.85)

Piaget (Piaget & Inhelder, 1973), when reporting results of studies conducted on human memory so as to discuss the relationships between memory and intelligence speaks specifically about "remembrance" making the reconstructive character of this process explicit by saying:

*"... remembrance is the combined result of mnemonic retention and reconstruction; and reconstruction often goes hand in hand with reactivation of the underlying operational schemata."* (Piaget & Inhelder, 1973, p.114)

The hypothesis that memory is strongly influenced by experience is crucial for this study as its main intention is not carrying out a retrospective survey but rather, to obtain information about people's feelings towards, their interest in, and their understandings of the subject. What one remembers about an event may provide some indication about what has most attracted attention, most or may reflect a particular concern or interest.

## **5.5 CHARACTERISING GROUPS OF INTEREST**

The choice of secondary school teachers and students as the target populations is an attempt to address directly the issue of the role which should be attributed to secondary school education as a mediator in the interaction of the scientific community, as producers of scientific knowledge, and ordinary people, seen as consumers of its technological applications. It is, therefore, in the context of the communication of scientific ideas to non-experts and of the necessary re-contextualisations, translations, adaptations and transpositions that the explanations

both secondary school teachers and students might have of the topic acquire special interest.

However, it is not at all easy to characterise these two universes, as Brazilian secondary education is essentially heterogeneous and diverse. This is due both to the diversity of features which characterise the way the Brazilian Educational System is organised and the cultural and regional differences it is possible to find in it.

Secondary school science teachers are trained in tertiary level courses ("Licenciatura"). Most of them are trained in Biology with two disciplines in General Physics, or in Physics, with no disciplines in Biology at all. With some exceptions, teachers are generally badly prepared. There is hardly any control of the quality of text books, with abridged publications being often preferred by teachers because of their low cost and low academic demand. It is also possible that the same teachers may teach at both state and private schools, though teaching at private schools is considered to be of a much higher standard.

At secondary school, students are offered three different modalities of courses, namely, vocational courses, primary teacher training courses and regular courses. The vocational courses, which have been disappearing since they became non-obligatory in 1981, can take up to four years and are supposed to cover the regular syllabus plus specific training for a technical qualification. The primary teacher training course takes up to three years and includes the regular syllabus plus topics on psychology and sociology of education, pedagogy and didactics. However, in both cases, what happens, in practice, is that these additional subjects are followed at the expense of those from the regular courses.

The regular course covers a wide range of content. Physics, Chemistry and Biology are compulsory subjects in the three years of secondary school with 2 to 3 hours per week. The official timetable is hardly followed at state schools which makes secondary state schooling not effective to prepare students for university entrance examinations. For this reason, those who want a place at the University have to attend a private school or a preparation course whose pedagogical methods emphasise the ability to solve formal problems. In fact, the standard of secondary state school regular courses has reduced considerably over the last two decades and this state of affairs is perhaps best described as a sort of vicious circle, which has

positive feedback and reinforcement as state secondary school become stigmatised as bringing together badly-prepared under-paid teachers with low ability students mainly from a poor socio-cultural background who have been exposed to adverse learning conditions, so as to produce a low quality education. Even now at state schools, regular courses are offered in three shifts, namely, morning, afternoon and evening. Morning and afternoon shifts cover five hours per day whereas the night shift covers only four hours per day. Night shift courses are generally preferred by students who are engaged in some kind of professional activity during the day or by low ability students seeking a lower standard course where the contents may not be discussed in depth in view of students' greater difficulties.

By contrast, private schools tend, in general, to be able to provide better teaching and attract middle-class or upper middle-class children, who have naturally been more stimulated at home, and for whom tertiary education is a goal. Night shift classes are practically non-existent in private schools. Some of them have strict criteria for selecting their students who may be, sometimes, ranked in low, medium and high ability bands.

Because of this heterogeneity amongst secondary schools, it was decided to include both state and private schools in the sample, since that would enable possible differences between these two groups to emerge both concerning the degree of background information possessed on the subject, and the extent to which a better understanding of related topics in Physics could influence understanding of radioactivity related information.

Within the state schools a sub-sample of night shift school students was taken so as to see whether these subjects, being adults, who may be providing for themselves and their families, and are compulsory voters who therefore may have a higher level of commitment to social responsibilities, might present different views on the subject or be interested in it either at a higher level or in a broader perspective.

## **5.6 RESEARCH DESIGN: TYPES OF INFORMATION AND INSTRUMENTS FOR DATA COLLECTION**

The requirement of the study present two conflicting demands. One is to survey rather widely, finding out about sources of information and ideas about radioactivity. But this approach could not investigate the point previously stressed,

that it would be important to investigate what sense people could make of information if they had time to think about it.

The decision made was that the enquiry would benefit from a combined approach which could provide us with both types of data. The research design thus comprised a quantitative and a qualitative study. It would then be possible to quantify and measure the degree of interaction subjects had had with radioactivity related information at the time of the accident of Goiânia and the elements, as present in our working model, of their conceptualisation, could both be explored. A complementary qualitative study would then attempt to characterise subjects' conceptualisation of the subject and to investigate how prior knowledge might shape understanding of new related information. Both studies would be conducted in parallel with students and teachers so that comparisons could be made between these two groups.

Thus the framing of the questions followed a structure which is depicted in figure 5.1.

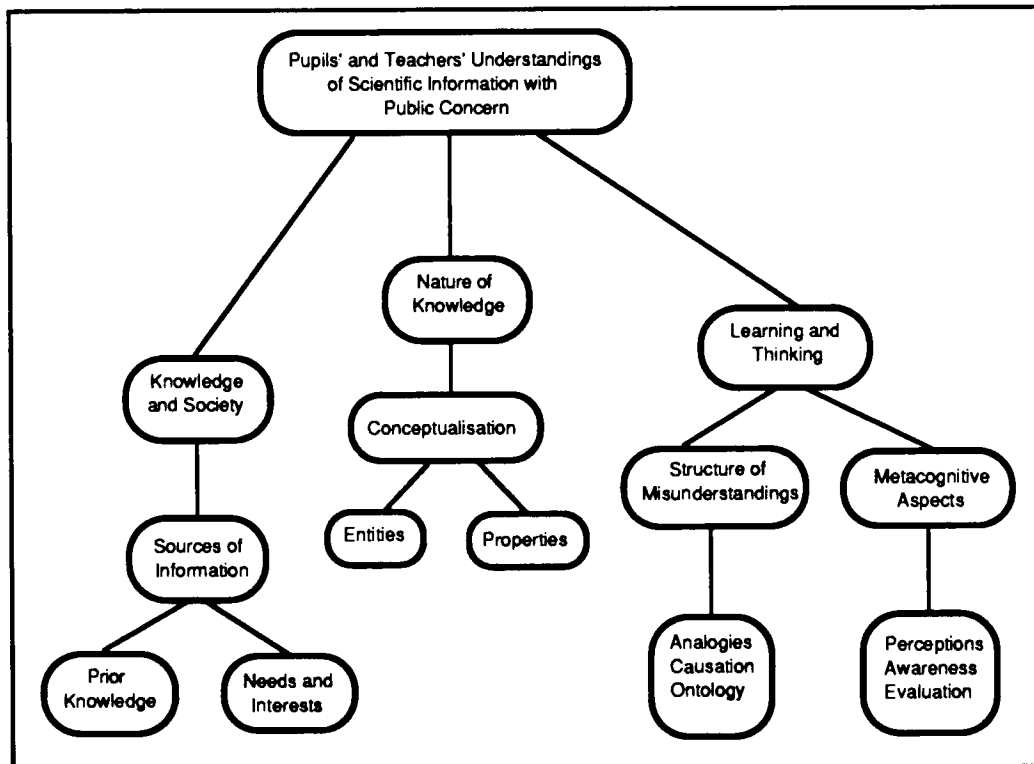

Figure 5.1: General Scheme for Framing the Questions

For the reasons stated above, it was decided to use different instruments for data collection. Information concerning Sources of Knowledge was thought to be best obtained through a questionnaire. Likewise, information on Nature of Knowledge

could also be collected through a paper and pencil task containing both multiple choice and open-ended questions.

Information on Learning and Thinking required a different kind of investigation in which students' answers could not only be probed but also expressed and followed up in a more systematic way so as to explore their ideas at greater depth. More important, it was necessary to guarantee that this investigation would create an effective engagement in making sense of new information.

Interviews conducted with groups, rather than with only one individual, were considered to be appropriate in as much as they permitted mutual support and encouragement. They would be also a means of stimulating a debate where ideas are made explicit and can be challenged in a more natural way. The idea of having a task to be accomplished in groups, namely, reading and summarising a text, was introduced so as to facilitate the engagement of participants in the discussion.

The idea of having more than one type of data as well as more than one type of research instrument so that the problem is being investigated and examined in different ways, can be thought of as "triangulation". By employing different methodologies and sources of data greater confidence in the findings might be achieved. As Bryman says:

*"By combining the two, the researcher's claims for the validity of his or her conclusions are enhanced if they can be shown to provide mutual confirmation." (Bryman, 1988, p.131)*

Although it is still possible to learn from responses given in different contexts, the instruments were designed so as to deal with specific aspects of the problem. Thus, the questionnaire surveys the kind of previous information subjects had on the topic as well as their conceptualisations of the nature of entities to be at work. The interviews, conducted with a sub-sample of the students who took part in the quantitative study, represent an attempt to go beneath the surface of the most common misunderstandings as well as discussing types of reasoning and strategies of cognition.

Overall, then, the following data were collected:

1. Questionnaire to students about sources of and their confidence in their knowledge of radioactivity.
2. Questionnaire to students probing the nature of their conceptions of radioactivity.
3. Interview with students about how they understand texts about radioactivity.
4. Interview with students reconstructing their understanding of a text.
5. Questionnaire to teachers asking for predictions of students' interest and knowledge.
6. Interview with teachers about their understanding of students' conceptions and their perception of their difficulties.

### 5.6.1 KNOWLEDGE AND SOCIETY

One intention of this research is to discuss the extent to which prior knowledge shapes understanding. Knowledge of the kinds of information with which subjects had contact, the sources of this information, and their specific interests and motivations to know about radioactivity are therefore of importance. Thus, it was decided to investigate the level of interaction which the subjects might have had with information through the media coverage of the radiological accident at Goiânia, so as to be able to characterise their prior knowledge, their sources of information, their interests and their perceived needs to know more, and their self-evaluation of their understandings. The questionnaire was designed so as to deal with questions such as:

---

*To what extent are subjects familiar with radioactivity related vocabulary ?*

*What kinds of factual objective information about radioactivity do subjects possess?*

*What are the ways in which the interaction of radioactivity both with the environment and with matter is explained by the subjects?*

*In which perspective does the topic attract the attention of the subjects?*

*How interested are subjects in knowing more about radioactivity?*

*What are the reasons for being interested in knowing more about radioactivity?*

*What are subjects' sources of information?*

*How do they see themselves in relation to this kind of knowledge?*

*Who do they consider to be knowledgeable on the subject?*

---



It was possible to obtain information about each of these questions in different ways and in different levels of detail, depending on the instrument used. In the questionnaire both multiple-choice and open-ended questions were included though subjects were also asked to recall the circumstances surrounding the accident of Goiânia as well as their understandings of information as revealed in the interviews. This will be described more thoroughly in the next sections.

### 5.6.2 NATURE OF KNOWLEDGE

Another level of information required relates to subjects' conceptualisation of the entities involved and of the related processes and mechanisms <sup>which</sup> seem to be at work in explanatory accounts of radioactivity. In this case two main lines of enquiry were pursued. One in which one tries to learn about processes or behaviours through some knowledge of entities which resemble radioactivity. The other in which one tries to learn about the nature of radioactivity through knowledge of the processes through which it seems to operate and of some of its properties.

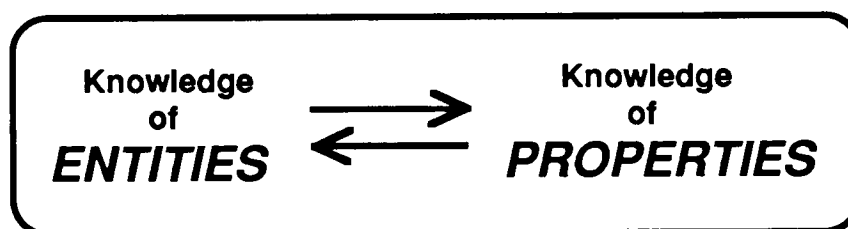

Figure 5.2: Relevant features for explanations

In the questionnaire, such information is obtained through many simple direct questions. The first question presents a list of entities and subjects are asked to tick or cross each one indicating whether, in their opinion, the entities resemble radioactivity in any way or not. The proposed entities were selected so as to include physical entities and objects of daily experience as well as images which were often used in connection to radioactivity in the media accounts. The entities most often chosen as well as the patterns of choices would give information about both associations and distinctions that were being made between the proposed entities and radioactivity. In other words, common features between a group of entities would give some indication of some characteristics and properties of radioactivity.

Conversely, information about some characteristics and properties radioactivity might have, would give some indication of how its nature is understood. A list of

characteristics or properties was presented and subjects were asked to express their opinions as to whether radioactivity possessed each by ticking a five-point scale. Characteristics were selected so as to reflect properties connected with the nature of radioactivity.

In this case it was decided to use an adaptation of the technique known as the "semantic differential" (Osgood et al, 1957). The main purpose of using this instrument is to be able to gather information about some of the properties radioactivity might have in lay people's views, so as to establish what would be the most salient features in their interpretations of the subjects.

*"... essentially a combination of controlled association and scaling procedures. We provide the subjects with a concept to be differentiated and a set of bi-polar adjectival scales against which to do it, his only task being to indicate, for each item (pairing of a concept with a scale), the direction of his association and its intensity in a seven-point scale. The crux of the method, of course, lies in selecting the sample of descriptive polar terms. Ideally the sample should be as representative as possible of all the ways in which meaningful judgements can vary, and yet be small enough in size to be efficient in practice. In other words, from the myriad linguistic and non-linguistic behaviours mediated by symbolic processes, we select a small but carefully devised sample, a sample which we shall try to demonstrate is chiefly indicative of the ways that meanings vary, and largely insensitive to other sources of variation." (Osgood et al, 1957, p.20)*

In the present research, information both about preferences and differences in opinion of different groups of people will be investigated.

The use of bi-polar scales presents another advantage in this case where ill-formed knowledge is the target. It makes the definition of characteristics and properties explicit leaving no space for ambiguities in interpretation. In other words, the meaning of a given adjective from a given scale is made explicit by the contrast made with the intended complementary meaning. This allows a more stable and clear meaning to be attributed to the scale. Consider the following example. If somebody says he believes radioactivity is momentary it is not possible to infer whether he means *momentary as opposed to lasting* or *momentary as opposed to eternal* or *momentary as opposed to permanent*. This variety of meanings may be problematic if one wants to draw inferences with respect to the distinct properties a concept may have. For this reason, it was decided to include as many distinctions as possible so as to obtain a more precise interpretation of the properties subjects would attribute to the concept. Thus, it was possible to have distinctions such as

momentary vs eternal, brief vs lasting and permanent vs transient<sup>1</sup>. Subjects were supposed to tick the point in the scale indicating whether any of the proposed adjectives is applicable to radioactivity. If both adjectives are equally applicable the mid-point in the scale should be then ticked. Therefore, a choice for one pole also indicates a non-choice for the opposite pole. Whenever possible, special effort was made so as to choose adjectives which had opposites so as to avoid having an adjective at one extreme of the scale and its negation at the other. Apart from that “positive” and “negative” ends were randomly distributed so as to diminish bias.

The dimensions (properties) defined by each scale (for example transient vs permanent, permanence/transience) is like what is understood by a ‘construct’ as in George Kelly’s Personal Construct Theory (Kelly, 1955). However, they are best seen as an attempt to acquire systematic pieces of information which can be related to one another so as to suggest possible dimensions (properties) which seem to apply to the concept of radioactivity.

One common characteristic in the two approaches is that both require quick answers. Both in the question to tick or cross entities which resemble radioactivity and in the semantic differential one is asking for straightforward responses through immediate judgements. A first impression so as to represent an immediate feeling is what is wanted. In fact, in the case of the semantic differential, a thorough checking across scales may generate confusion for the respondent and result in a “central tendency” effect. For this reason, the ‘positive’ and ‘negative’ poles of each scale are randomly distributed and adjectives which may be regarded as being, in any way, similar or related are also distributed along the list of scales.

Both approaches deal with questions such as:

---

*Which associations are made in respect to radioactivity?*

*Which types of entities are mentioned in accounts of radioactivity related phenomena?*

*What sort of causation is associated with radioactivity?*

*Which processes are seen as at work in relation to radioactivity related phenomena?*

---



---

<sup>1</sup>Antonyms were chosen with respect to the closest match (or mismatch) with reference to Brazilian Portuguese.

### 5.6.3 LEARNING AND THINKING

The remaining goal is to investigate people's attempts to make sense of new information in terms of their pre-existing knowledge, so that modes of explaining, articulating and presenting ideas could be better understood. That is to say, to observe a dynamic process of learning, as well as being able to record ideas which could substantiate information already obtained through other instruments. The first step was to devise some methodology which enabled this to take place.

As emphasised previously the aim of this enquiry is to understand better ways through which previous knowledge affects understanding. One way of investigating this can be watching a group discuss "problematic" information. The criteria used to decide for a given topic was a mixture of its potential utility in the classroom and the degree to which it dealt with topics which illustrate differences between commonsense and scientific knowledge. They should also correspond to topics students had said they were interested in learning more about and should raise questions about the nature of the entities and processes involved in the phenomena. Examples of these are: (i) continuity with daily life (ordinary) experience (e.g. x-rays, sunlight); (ii) processes of irradiation and contamination (transformations in matter, power to change); (iii) ambiguity of effects (being able both to cure and to cause cancer); and so on.

There were several reasons for deciding on an interview as appropriate to elicit the kind of information wanted. There were also reasons for deciding on a *group, semi-structured, focused, non-directive* type of interview.

The main reason for deciding on an interview was that it was necessary to create an opportunity for such "processing of information" to happen and to be watched. The purpose of performing the interviews with groups is twofold. First the group allows mutual support and puts less stress on a single person. Second it allows a more "natural" discussion to evolve as mutual criticism and questions asked to one another diminishes the need for constant interference from the interviewer. Students' explanations will be, therefore, analysed in the context of communication and the negotiation of ideas.

A reasonable level of flexibility and freedom was also desirable as it would contribute to a less artificial and "pressurized" atmosphere. It was therefore decided

that the interview should not be a closed situation, and that, features like wording and sequence of the questions could, if necessary, be changed according to particular characteristics of the subjects. On the other hand, the content of the questions should be, whenever possible, kept the same in order to allow comparisons. Moreover, the possibility of both cross-checking information obtained from different instruments and establishing relationships between variables should be guaranteed. A way of introducing more control into the situation was to use the focused interview technique. As explained by Cohen & Manion:

*" The distinctive feature of this type [of interview] is that it focuses on a respondent's subjective responses to a known situation in which he has been involved and which has been analysed by the interviewer prior to the interview. He [the researcher] is thereby able to use the data from the interview to substantiate or reject previously formulated hypotheses."*  
[Cohen & Manion, 1989, p.310]

This led to two major decisions: (i) to include explicit reference to interaction with radioactivity related information at the time of the accident at Goiânia and; (ii) the choice of an activity that provided not only context for the discussion but also a shared background to be experienced by the group. By asking for recollections about subjects' own interaction with information about the Goiânia incident, there would be grounds for comparisons with responses given by students in the quantitative study, but this would also help clarify the interpretations given to students ideas about the nature of radioactivity.

The choice of a non-directive interview was made to facilitate the engagement and commitment of participants to the discussion. Only voluntary subjects took part in the interview study. Apart from that, once the discussion has been initiated, it evolved differently for each group, that is, spontaneously, depending on the degree of group interaction. The discussion was triggered by the interviewer who presents the group with problematic information to deal with but the course of the discussion is directed by the group. The subject matter of the discussion will be changed either by the group as the discussion evolves or by the interviewer if the group agrees there is nothing else to be said.

In summary, the choice of a group interview with the characteristics described above aimed at *avoiding* problems such as:

- (i) overcoming the blockage of having to discuss a difficult and unfamiliar topic;
- (ii) subjects having their attention driven to related parallel aspects of the topic, for example to be tempted to express their opinions, judgements, personal feelings and concerns rather than concentrating on the understanding of the content of the information;
- (iii) subjects not being clear about the objectives of the discussion and, therefore, not being able to go about the proposed task.

The idea of having a specific activity to be accomplished by the group was adopted as an attempt to counter the problems described above. It would also impose some constraints on the course of the discussion, forcing subjects to stick to the topic. Nonetheless two main conditions should be fulfilled. It should not be too demanding so as to provoke defensive reactions. On the other hand, it should not be too simple so that subjects regarded it as trivial and did not feel challenged when trying to make sense of it. The activity chosen was the reading of a text containing explanations about radioactivity, and then summarising the information contained in the text by constructing a semantic network. This served as a means of making subjects talk about the information contained in the text and to make their difficulties explicit.

Semantic networks are a well-known method of representing knowledge by means of a diagrammatic arrangement of concepts linked to one another by links which describe some kind of directed relationship. They use a structure organised as a set of nodes and relations. The nodes represent entities or concepts and the labelled and directed relations represent how nodes are associated. The pattern of relationship for a given node will determine its meaning and allow inferences with respect to its properties and its relationship with other nodes. Common links which are used between nodes are *is a*, which indicates set inclusion, *is*, for attributing properties and *has* for attributing proper parts. Event nodes may also be linked by actions.

One interesting and useful feature of semantic networks is what is generally called 'inheritance properties'. This has to do with having different kinds of inter-relations among concepts and with the possibility of deriving, through certain processing strategies, other relations between nodes that are not directly linked.

Figure 5.3 illustrates an example of a semantic network chosen to illustrate the use of inheritance (Norman & Rumelhart, 1983). In this simple network part of our knowledge about animals is represented. From it, we can immediately note that animals breathe air, have mass, have limbs as a part and eat food. We can also note that Arthur and Elaine are examples of animals and that they must share the properties described above, like eating food for example. This is derived from the triples (Arthur is a person), (person subset of animal), and (animal eats food).

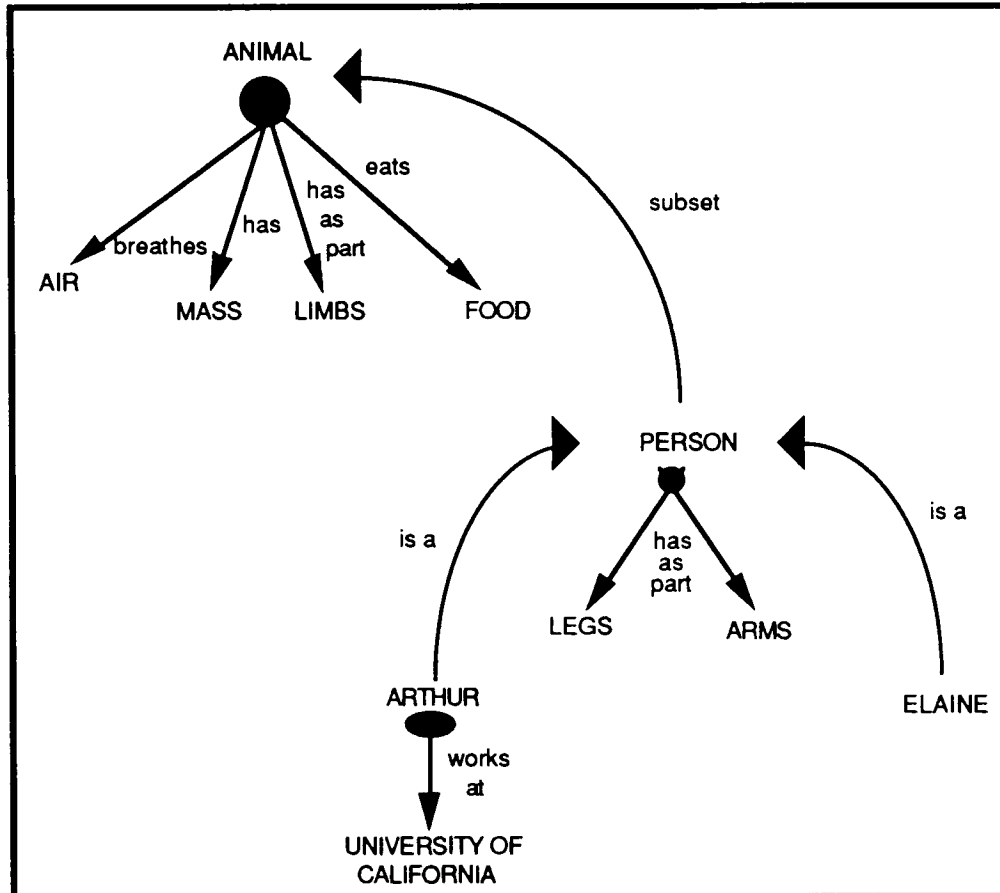

Figure 5.3: A simple semantic network to illustrate the property of inheritance. (Norman & Rumelhart, 1983)

In the case of the present research, the main objective of asking the subjects to construct a semantic network is to create a concrete activity which forces the subjects to make explicit some of their views on the subject, as well as to reveal strategies employed to interpret and make sense of the information, as the group tries to reach a consensus about essential information that should constitute the summary. At the same time it is hoped to benefit from the more specific nature of associations which can be made in the semantic network to understand better some of the associations previously made between radioactivity and other concepts in the questionnaire study. Information obtained then comprises the actual summaries

made by students as well as a transcript of the group discussion which took place during the construction of the nets. The transcripts can be used so as to understand better the meaning attributed to links in the network, to “fill in” more links, to characterise better the process of construction and the evolution and development of the argument, and to identify previously detected patterns of responses.

After reading the text students were asked to start the construction of the semantic net as a collective enterprise. Nodes could be chosen from a wide and comprehensive selection of concepts or events mentioned in the text. Links could be chosen from a collection of relationships of inclusion, attribution of properties and actions which aim at specifying the nature of entities associated with radioactivity as well as the nature of its active character.

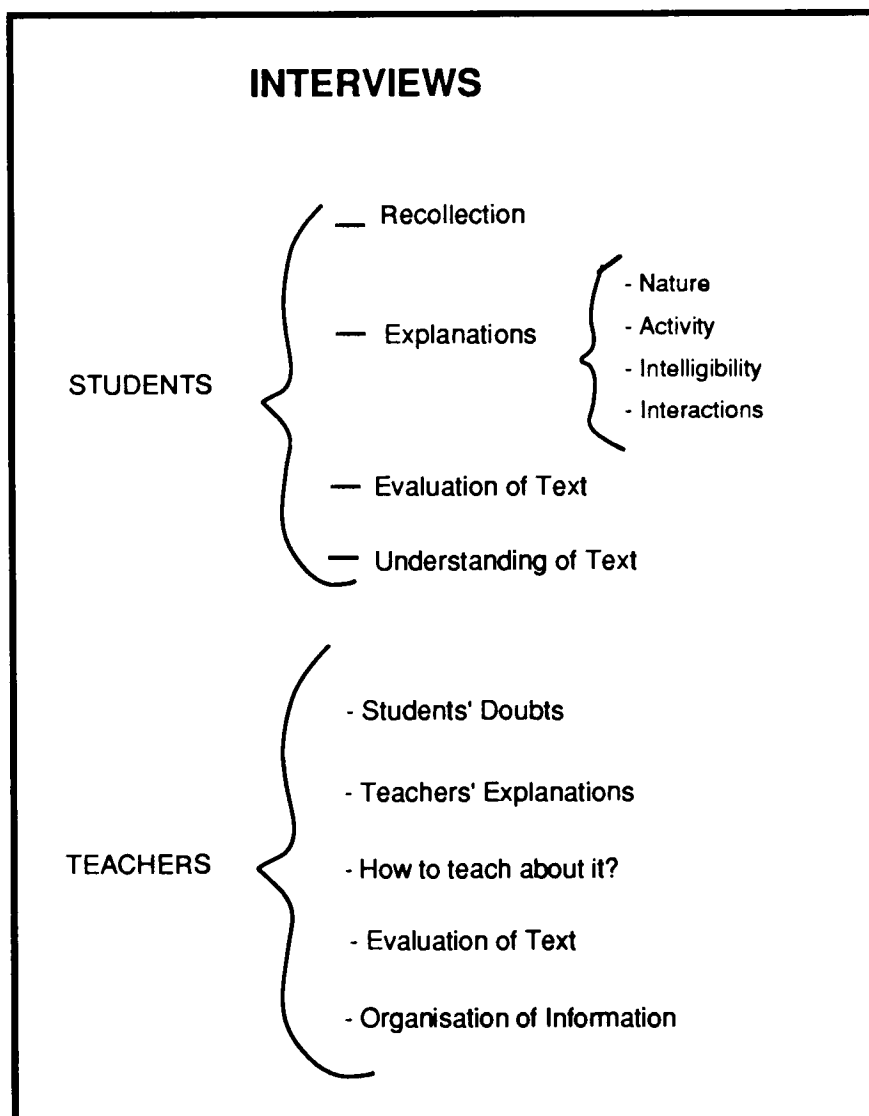

Figure 5.4: Framework for interviews with students and teachers.



Students' interviews dealt mainly with concrete recollection and interpretation of events related to the radiological accident at Goiânia and explanations about their understandings of radioactivity related matters, in particular of their conceptualisations of the entities involved.

The interview started by asking students what they remember about the accident and went on with the discussion of two pieces of news published in connection with the accident. These are shown in appendices 5.1 and 5.2.

The first piece of news (see appendix 5.1) shows a picture of the place where the medical device was opened delimitating the surrounding area that was isolated due to contamination. The news is about fruit from trees which were approximately 100 meters away from the isolated area and that were found to be contaminated. Students are not required to read the whole article only a small bit, corresponding to its first paragraph, which said:

---

---

### **New Foci of Contamination Appear**

---

---

A new focus of contamination by caesium-137 in Goiânia, outside of the isolated area, was found by physicists from Goiânia. Luiz Pinguelli Rosa, director of the Coordination of Post Graduate Studies in Engineering of the UFRJ (Federal University of Rio de Janeiro) and member of the Brazilian Society of Physics, said that two trees - one 60 meters and the other 100 meters away from the junk-yard owned by Devair Alves Pereira where the Caesium capsule was broken - presented radiation levels which are 20 times greater than that allowed by the Cnen (National Commission for Nuclear Energy) when milk, which had been contaminated in Chernobyl, was imported.

---

Jornal do Brasil, 12.11.87

The interviewer described the picture, re-stating information contained in the previous first paragraph of the article, and asked them to try and explain the contamination of distant bodies.

The second piece (see appendix 5.2) was a small extract from an article from the same newspaper, but dated June/89, 20 months after the presumed date of the accident. This article showed a picture of the project of a deposit to be built so as to

store "radioactive waste, generated during the accident with caesium ". Students were asked to examine the picture very carefully but not required to read the contents of the article.

The drawing, shown in appendix 5.2 shows (what are probably) depth and width of the area to be dug, and specifies layers of clay ("argila"), blocks of rocks ("monolitos") and layers for draining ("drenagem") as well as soil ("solo") which will be on the top of it. The text attached to the picture says:

---

The deposit, covered with concrete and with the capacity to store 3,400 cubic of radioactive waste, will be 30m and 50m high. The cost of the construction is approximately NCz\$1,4 million.

---

O Globo, 20.06.89

Students were then asked to explain why it was necessary to have a subterranean deposit and the need for different layers to cover it.

Students were also asked to explain how they thought radiation would affect the human body. No external reference was made in that case. Finally, they were asked whether they found it more difficult to conceive the nature of radiation/radioactivity or the processes through which it acts.

The text given to students (see appendix 5.3) was published in a newspaper one month after the accident was known to have happened, to be read and discussed. The text said:

---

## **RADIATION LASTS FOR THREE CENTURIES**

In 2300, atomic waste will still be emitting 1 curie.

---

Radioactivity is a natural process through which certain nuclei of atoms disintegrate, releasing energy and, forming, in general, new atoms. In this process, there is the emission of one or more types of radiation: the alpha and beta particles and the gamma rays.

The alpha particles have little power of penetration and can be stopped by a simple sheet of paper. It is worth mentioning that a person exposed to alpha radiation is caused damage only on her skin.

The beta particles are a bit more penetrating than the alpha particles. They are able to pass through a sheet of paper, but they do not pass through, for instance, a final foil of a light metal, like aluminium. For a person exposed to beta radiation, the damages caused go

beyond the skin, but are not deep either, unless the person has ingested or inhaled a substance which emits beta radiation. In this case, the particles would provoke greater damage, because they would be emitted from inside the body. That was what happened with the girl Leide das Neves Ferreira, who ingested the caesium 137 together with a boiled egg. Caesium emits beta particles when it disintegrates.

The gamma rays are much more penetrating. Thick layers of lead are the only thing they cannot pass through (that's why the lead shielding in the coffins of the victims of Goiânia). Thus, a person exposed to gamma radiation, for a long time, is caused damages in inner tissues of her body. When it disintegrates, caesium 137 transforms into barium 137, which emits gamma rays. That is why the victims from Goiânia were exposed to two types of radiation - beta and gamma.

When radiation passes through any material, it modifies the atoms of this material. This modification is called ionisation, that is, radiation takes electrons out of the atoms, changing the characteristics of the molecules constituted by these atoms (there are industrial applications in which radiation is deliberately used to change a given material, making it, for example, harder or more flexible).

When radiation passes through living tissue, it ionises [the] atoms of the tissue as well.

The consequence is that the cells that form this tissue are either destroyed or start to reproduce in an abnormal way. Actually, this is the very reason why, radiation is used to treat cancer but it can cause cancer too. Applied with proper care, in scientifically calculated doses, during a calculated time as well, and directed only to the organ which needs treatment, radiation kills the cancered cells. Applied without control, it may turn healthy cells in cancered cells. The frequency of when the cancer could happen is a statistical probability, as emphasises the medical doctor, Luiz Renato Caldas, chief of Radiology Unit of the "Servidores do Estado" Hospital. It is not guaranteed that an irradiated person will develop cancer, it's the probability that increases.

Radioactivity is measured in curies, as a tribute paid to the French-Polish researcher Marie Curie, who studies and clarified its mechanisms, having discovered, at the beginning of the century the element radium and, who died of cancer. As the physicist Aquilino Senra Martinez, from the Coppe/UFRJ (Coordination of Post Graduate Studies in Engineering of the Federal University of Rio de Janeiro), explains, one curie is equivalent to  $3.7 \times 10^{10}$  disintegrations per second. This means that one curie is equivalent to the radiation emitted by the disintegration of 37 billion of atoms per second. The CNEN (National Commission of Nuclear Energy) informs that medical device destroyed in Goiânia had, in 1971, when it was first made, a total activity of, 2000 curies. That is to say that, at that time, 74 trillion of atoms disintegrated (and, therefore, emitted radiation) in each second. When the caesium disintegrates it becomes barium. Because of that, last month, when the device was destroyed, there were less atoms inside it than in 1971 ( the CNEN estimates that in September the activity of the device had already decreased to 1370 curies, that is, 50 trillion 690 billion of caesium atoms disintegrating per second).

---

---

Jornal do Brasil, 23.10.87

Students were asked to indicate their overall impressions of the text, as well as to exemplify bits they considered easy or difficult to understand.

Having read the text, students were asked to construct a semantic net to summarise the text. This was a task to be accomplished by the group and the net should reflect a consensus. Nodes and links related to entities and events mentioned in the text.

In the interviews with teachers, they were asked if they could remember the most common questions they were asked about radioactivity related matters at the time of the accident of Goiânia. They were also asked about the most common types of "misconceptions" held by students which could be detected by them, at that time. They were also asked to reproduce the kinds of explanation they gave to students at that time and to exemplify which one(s) students appeared to have found particularly useful. Teachers had also to comment upon conceptual difficulties of the subject as well as other difficulties related to the teaching of radioactivity/radiation at secondary school level and to judge the text in terms of their intelligibility and adequacy to be read by secondary school students. They were also asked to comment about any other radioactivity related teaching material they happened to know.

## 5.7 SUMMARY

Several levels of information were thought to be needed so as to explore relevant areas of students' prior knowledge and ideas on radioactivity. They are: (i) Sources of Knowledge; (b) Nature of Knowledge and; (c) Learning and Thinking. This division is derived from the three major contexts the subject can be seen as situated in, namely the social, the theoretical and the educational contexts, as explained in section 2.2.

**SOURCES OF KNOWLEDGE or KNOWLEDGE AND SOCIETY:** As radioactivity is not a topic studied in detail at secondary school in Brazil the hypothesis that a good deal of the knowledge students possess about it may have been influenced by the media coverage of the radiological accident of Goiânia was made. Therefore in the corresponding part of the questionnaire there are explicit references to the accident at Goiânia. In order to have a general picture of students' interaction with radioactivity related information the general question "*What are students' relationships to knowledge and information about a specific scientific/technological event?*" was unfolded in four major aspects related to the

perception they had of their own interaction with information available at that time. The four major aspects are:

- (i) Concrete Recollection
- (ii) Sources of Information
- (iii) Self-evaluation of own understandings/knowledge
- (iv) Self-evaluation of interaction with related information

Asking the questions in this way made it possible to investigate the hypothesis that the radiological accident of Goiânia accident may have stimulated students to know more about radioactivity related issues.

**NATURE OF KNOWLEDGE:** At another level an identification of the way students perceive the nature of radioactivity and the processes through which it seems to work was also thought to be of special interest in as much as it suggests possible ways through which new information is interpreted in terms what is already known. This can be summarised by the following general points:

- (i) Common analogies employed when referring to radioactivity
- (ii) Nature of entities that seem to be at work
- (iii) Kinds of processes thought to be involved
- (iv) Specific knowledge held about "well-known" facts

The choice of a line of enquiry which avoids asking questions about people's knowledge of scientific facts can be argued for on the basis that asking such questions would not allow students to show their potential capabilities to understand new information but would rather emphasise their ignorance of scientific matters (see Section 5.3).

**LEARNING AND THINKING:** A further level of investigation relates to the way previous knowledge is actually used in a dynamic process of trying to make sense of, understand and interpret new information. It relates to an attempt to dig under the most common types of misconceptions raising questions about students' conceptualisation of the subject and kinds of explanation in the context of the communication of ideas. It is an elaboration of the previous point, in the sense the analysis of explanations given by students will be based on the underlying features

(nature of entities, processes and causation) specified in the paragraph above. It is also an attempt to explore issues on thinking and learning as well as on how to use previous knowledge in making sense of the new. Issues related to this level include:

- (i) The extent to which prior knowledge shapes people's understanding of new related information
- (ii) Modes of explanation present in people's accounts
- (iii) Role of analogies in explanation
- (iv) Ways in which information is organised and communicated

---

---

## CHAPTER VI

### THE PILOT STUDY

---

---

#### 6.1 INTRODUCTION

In this chapter the results of a pilot study will be presented. The purpose of including and examining data from this early study is twofold. The discussion will concern the implications of the results for the design of the questionnaire and interview used in the main study. However, it also obtained data about sources of information concerning the accident at Goiânia which was not collected in the main study, and so is worth reporting here.

The study consists of two complementary parts: the administration of a written questionnaire to Brazilian secondary school students and a small scale interview study conducted with Brazilian non-science professionals.

#### 6.2 THE QUESTIONNAIRE STUDY

##### 6.2.1 THE SAMPLE

The questionnaire study was conducted with 73 students from two state schools and one private school in the urban area of the city of Rio de Janeiro, Brazil. All students were from the last year of regular secondary school. These students had 9 hours per week of science lessons, these being divided into Physics, Chemistry and Biology and taught by three different teachers. By the end of the third and last year of secondary school they would have covered the corresponding basic required syllabi which do not include any formal teaching about ionising radiation. Some of them might have had contact with related topics. For instance, radioactivity is likely to be mentioned in Chemistry when atomic structure of matter is discussed as well

as in Biology if effects of exposure to radiation are explained or, perhaps, in Physics considering alternative sources of energy. Despite how wide-ranging the possibilities of getting information about the subject might be, this is done in an episodic and non-systematic way.

Three groups can be identified within this sample: one is composed of 22 students from a private school, the other included 32 from the morning shift of a public state school while the remaining 19 are from the night shift of a public school. The age range and mean age for each group is shown in Table 6.1<sup>1</sup>.

SCHOOL		MEAN AGE (YO)	AGE RANGE (YO)
PRIVATE		17	15 TO 19
PUBLIC	M	18	15 TO 22
	N	24	16 TO 40

Table 6.1: Mean age and Age Range of students in the sample as reported either by themselves or their teachers.

As far as the aims of our inquiry are concerned night shift students do constitute a group of special interest in as much as they may differ from morning shift students in relation to both their specific particular interests in and their commitment to learning about the subject. Furthermore it is possible to investigate whether or not there is a significant difference in the possibilities the three groups had for obtaining and using related information.

A detailed account of the aims of the inquiry and a description of the objectives of the pilot study is given in the next section.

---

<sup>1</sup>It should be noted that in the Brazilian Educational System progression is not related to age but conditioned to passing annual examinations conducted by each school.



### 6.2.2 **The Instrument**

The questionnaire (shown in appendix 6.1) dealt with both general and specific questions such as:

What was the level of interaction students had with radioactivity related information at the time of the radiological accident of Goiânia?

How well do they remember the accident itself?

What were the sources of information available for them at that time?

Were teachers and/or school books a frequently requested source of information?

How familiar with the "scientific" vocabulary are students?

Which kinds of previous information did they possess?

Did the radiological accident of Goiânia stimulate students to know more about radioactivity? In which perspective?

How do students evaluate their own understanding of the information they had contact with?

What do they see as the nature of this information?

How relevant is previous knowledge for the understanding of new related information?

What is the conceptualisation of the nature of radioactivity?

Which radioactivity related topics are they interested in knowing more about?

Where students were asked to report back about information available in the media, a classification into four major categories was made:

- (i) Scientific information about the nature of radioactivity
- (ii) Medical information about the effects of radiation
- (iii) Information about causes of the accident
- (iv) Information about both control and security measures required

Categories used in order to organise types of information derive from an analysis of a sample of available articles from the main newspapers and magazines published at that time in Rio de Janeiro in the first month that followed the event. Apart from these options there was a blank space in case students wanted to mention another type of information which would not match these.

### 6.2.3 SUMMARY OF RESULTS

Results will be presented under the three main headings “Knowledge and Society”, “Nature of Knowledge” and “Learning and Thinking”. In addition to overall totals, results for each school group will be presented as they may indicate possible differences between them which may be worth examining at a later stage.

#### 6.2.3.1 Knowledge and Society

The results are presented in groups, as follows:

- 
- (a) Concrete recollection;
  - (b) Self-evaluation of own knowledge/understanding;
  - (c) Sources of information ;
  - (d) Self-evaluation of own interaction with related information.
- 

##### 6.2.3.1.1 Concrete Recollection

When asked to say how well they remembered the radiological accident at Goiânia, more than half of the total number of subjects said they remembered the facts quite well. In spite of that only a minority succeeded in giving the correct answers to specific questions like, for example, "How many people were killed in this accident?". With respect to this particular question nearly half of the subjects did not remember the number of victims (which was, in fact, four) whereas a third overestimated it, as shown in charts 6.1 and 6.2.

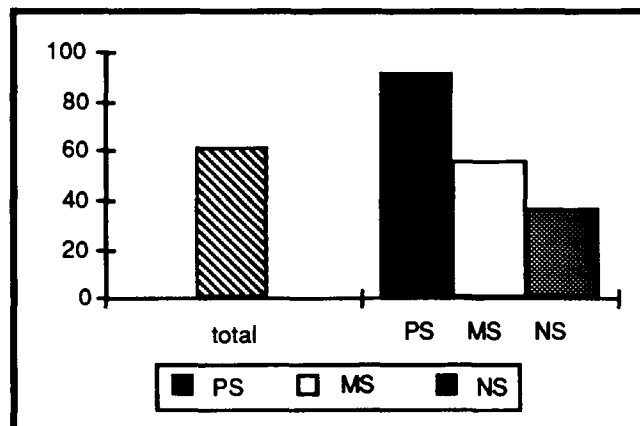

Chart 6.1 : Total and breakdown for option "quite sure" in question "How sure you are of remembering what happened?"

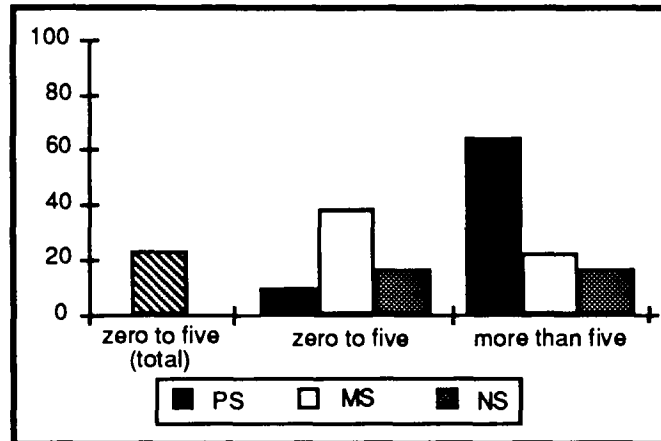

Chart 6.2: Totals and breakdown for answers to question "How many people were killed in the accident?"

In the case of this question about how sure students are of remembering what happened, there are interesting differences between groups ( $\chi^2= 13.31$ , 4 df,  $p\approx 0.001$ ) with the private school students most often feeling sure and the night shift public school students less often.

There are also differences between the answers given by students to the question of how many people were killed as a consequence of the accident ( $\chi^2= 18.41$ , 4 df,  $p \approx 0.001$ ). In this case the private school group, which claimed to feel sure about remembering what happened, presents the lowest proportion of correct answers.

The accounts given for the facts tended to be lacking in detail and coherence. Relevant specific information was not mentioned, nor were the actual sequence and course of events preserved in the brief summaries they gave. Key-words mentioned were Caesium, powder, ignorance, catastrophe, calamity, contamination. Typical accounts would be<sup>2</sup>:

*"A medical device used ...in a hospital...was left unattended and stolen. Some people opened the device and radiation then spread all over."* (PS3)

*" There was an abandoned hospital where a steel box containing Caesium was found. People living in the city got contaminated due to ignorance."* (PS10)

*"The whole thing started when a small group of people involuntarily found a greenish powder, these people lacking adequate information*

<sup>2</sup>Codes in brackets identify subjects according to which school group they belong, with PS, MS and NS standing for private school, morning shift public school and night shift public school respectively.

*took it as they thought that could be sold for a good price. That was how contamination started."* (MS28)

*"A box was found by people who worked in a junk-yard... they opened it and rubbed [ it - the content - into] their skins without knowing that they were dealing with a radioactive element".* (PS11)

The opening of the lead cylinder was described as voluntary and intentional while the spreading of the radioactive material was regarded as inevitable. The fact that the material was in the form of compressed powder was well known and mentioned in many accounts. The fact that the consequences were made worse due to people's ignorance was also stressed as well as the irresponsibility of the authorities in letting such a dangerous device be unattended in an abandoned hospital. Only a few people expressed a purely emotional concern about the fact that there were victims, the majority giving statements which showed some more articulate indignation grounded on arguments about the role of the responsible authorities, rather than giving a mere expression of a feeling. There were also different degrees of specificity in the accounts which ranged from very diffuse and vague to very specific ones. However the latter were a minority. For example, only one student was more specific as far as the nature of radioactivity is concerned saying:

*"... have radioactivity ... important metals such as Polonium, Thorium, etc... Bodies which are capable of emitting invisible rays that pass through opaques bodies."* (MS34)

As an example of a quite unclear account which was not very informative is:

*"I don't remember very well... from what I've heard it was an explosion that, it seems to me, happened due to recklessness."* (NS64)

The responses, as well as giving information about the actual concrete recollections also gave data from the vocabulary employed which would suggest the existence of different interpretations of the concepts of radiation, radioactivity and radioactive material.

When describing the event a majority of students refer either to Caesium or to a radioactive material. Very few mentioned radiation and an even smaller number mentioned radioactivity. Caesium is identified as "a bluish powder" some people had contact with, which caused both deaths and contamination, though the processes through which this contamination occurs are not made explicit. The term "radioactive material" is used in a vaguer sense in accounts in which two kinds of

events, namely “the finding of some radioactive material” and “people getting contaminated” are associated in an unspecific way. The preference for using the term “radioactive material” does not seem reflect an attempt to be more specific or to exhibit a clearer understanding of the concepts under question, as illustrated by the sentences below:

*“A radioactive material called Caesium was found in a junk-yard and because it had a nice appearance was taken home. Through the contact with Caesium, some people got contaminated.” (MS22)*

*“...an accident with Caesium, a radioactive product, which provoked deaths...” (MS30)*

The terms radiation and radioactivity were employed less frequently but in a similarly imprecise way. Although accounts like these were very few and not very clear they suggest a confusion as far as both the nature and the properties of each concept are concerned as indicated by, for example:

*“Caesium was taken out of a capsule releasing gamma radiation” (PS15)*

*“It has got radioactivity... important metals such as Polonium, Thorium, etc...” (MS34)*

*“ Someone touched something radioactive which in its turn spread radioactivity...” (NS68)*

There were also accounts which avoided mentioning any of the three concepts explicitly, though some suggested possible ways in which this “unspecified entity” could be seen, for example:

*“It was found in a hospital and taken to a junk-yard where it was opened... the children of the owner played with it and ... put it into their mouths.” (MS45)*

*“I remember it was a gas that spread in the air contaminating a lot of people” (NS57).*

The fact that, in this case, students' answers cannot be followed up and probed limits the interpretation one can make and the inferences able to be drawn from such examples. Nevertheless points concerning a possible differentiation between these concepts and the ways they are seen, will be elaborated later after related results concerning Nature of Knowledge have been presented.

The number of subjects who do not provide any account at all is greater in the night shift group by contrast with the private school group. Furthermore, private school students' accounts tend to give more details about circumstances related to the event, which, however, does not imply a clearer or more faithful picture of reality.

**6.2.3.1.2 Self-Evaluation of Own Knowledge/Understanding**

Most of the subjects said they knew something about radioactivity *before* the accident of Goiânia and according to nearly half of those who claimed to possess some kind of prior knowledge, this knowledge was enough to understand the comments made about radioactivity at the time of the accident. However, despite the fact they consider this knowledge sufficient, two thirds of these students said they had looked for more information as shown in figure 6.1.

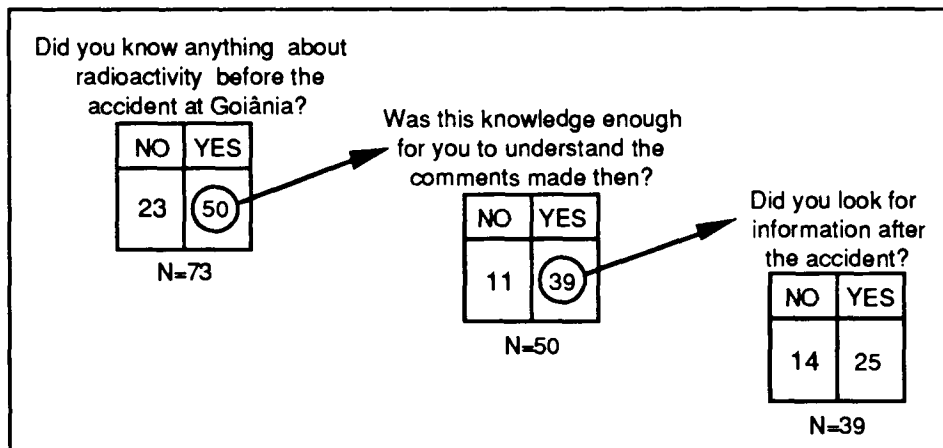

Figure 6.1: Totals for questions about evaluation of previous knowledge and need for more information.

From this data it can be seen that almost three quarters of the students claimed to know something previously about radioactivity. Out of this number a large majority considered this knowledge as enough to evaluate the seriousness of the situation.

Charts 6.3, 6.4 and 6.5 show the totals and the breakdown for each school group of all the answers to the questions discussed above. More than half of students report they knew something about radioactivity before the accident and that this knowledge was enough to understand comments made at that time. Private school students differ significantly ( $\chi^2= 9.81, 2 \text{ df}, p=0.01$ ) from both morning and

night shift public school students in as much as nearly all of them claim to possess some knowledge about radioactivity prior to the accident. However, chart 6.4 shows that, for all groups, the fraction which claimed to have some prior knowledge considered it as not entirely sufficient to allow an understanding of comments made about radioactivity at that time.

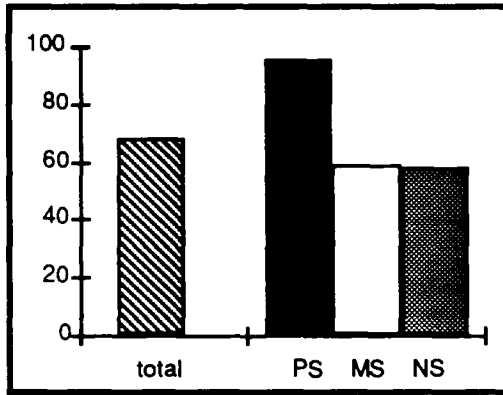

Chart 6.3: Total and breakdown for 'yes answers' to question: "Did you know anything about radioactivity *before* the accident?"

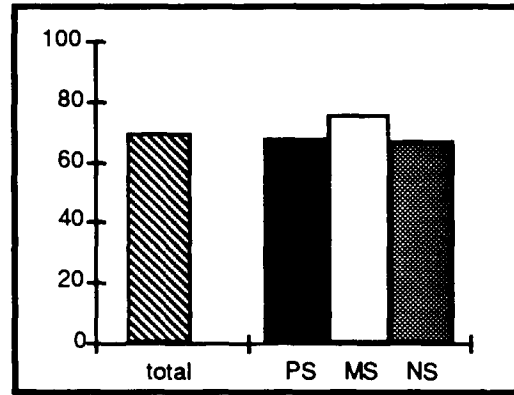

Chart 6.4: Total and breakdown for 'yes answers' to question: "Was this knowledge enough to understand comments made at that time?"

With respect to the question of looking for information after the accident the results appear to suggest that the accident did in fact motivate students to know more about radioactivity, with differences between groups also not being statistically significant in this case.

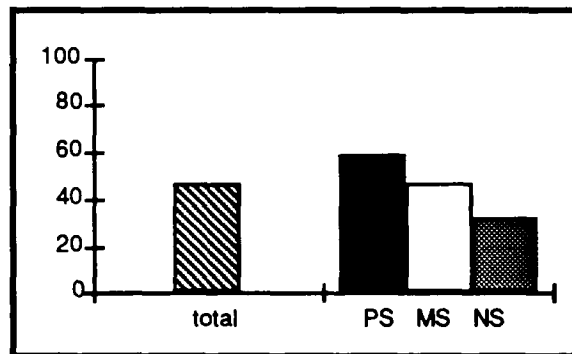

Chart 6.5: Total and breakdown for yes answers to question: "Did you look for information about radioactivity *after* the accident?"

In the previous item, evidence that the event is not well recalled and that the accounts given by students, in general, lack in detail and indicate a level of misinformation on the subject, was shown. This is consistent with the fact that, in

all groups, only a minority of students could realise the seriousness of the situation right away. For a majority it was three days or more after information about the possible consequences and the control measures taken had been widely broadcast, that its seriousness was realised.

In the answers given to the question about feeling capable or not of evaluating risks at that time and why, half of the subjects said they could not, and that not being capable of evaluating the risks had to do with lack of both previous knowledge and relevant information. Most of the responses of this kind are from private school students who show a significantly different pattern of choices from the others ( $\chi^2=10.10, 2 \text{ df}, p=0.01$ ). The main reason given for feeling capable of evaluating risks was that some kind of previous knowledge was held. However, the question may be considered as not very informative, as far as providing information about their understandings of risks is concerned, in the sense that it may have merely provided students with another context in which they could report their difficulties in understanding the subject. This is said based on the actual reasons students gave for their answers which, as said earlier, were expressions of dissatisfaction with the amount and quality of both their knowledge and understanding of the information they either had or came across. This could explain why, although students' accounts tend both to be lacking in detail and to indicate a level of misinformation, they consider their knowledge satisfactory. It may be the case that this knowledge was enough until the devastating consequences of the event were fully known.

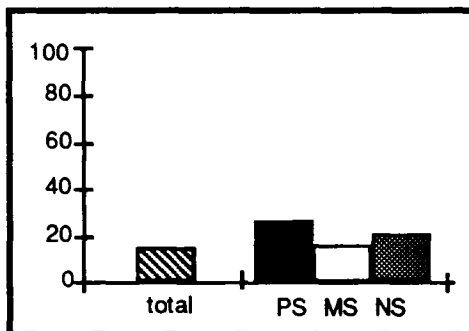

Chart 6.6: Total and breakdown for option "one day" to question: "How long did it take till you were able to realise the seriousness of the situation?"

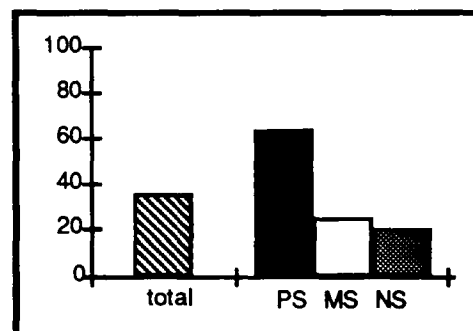

Chart 6.7: Total and breakdown of 'yes answers' to question: "Did you feel capable of evaluating the risks at that time?"



### 6.2.3.1.3 Sources of information

TV accounted for more than three quarters of the answers to the question about where people first heard about the accident, as shown in Chart 6.8. Other sources mentioned, although much less often, were radio and newspapers. It is interesting to point out that students do not report having first heard of the accident through an environment like school or work, for example but through means of communication instead. It should be noted that, since students were able to tick more than one option the data are presented as the fraction of total choices made, per group<sup>3</sup>.

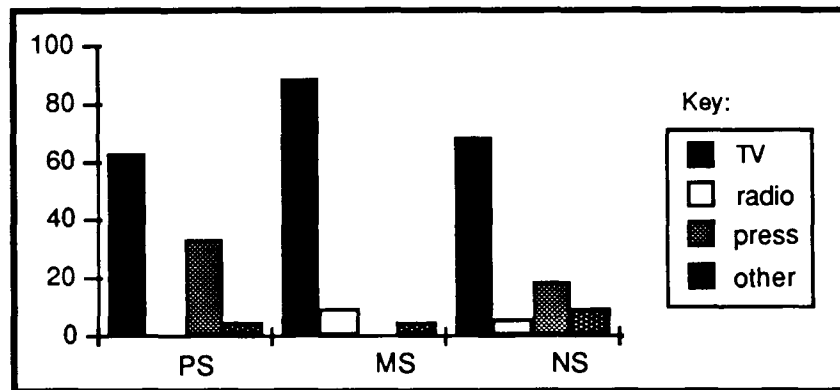

Chart 6.8: Breakdown for options presented to "Where did you first hear about the accident?" (percentages calculated over total number of choices for each option)

A third of the students said they know something about radioactivity before the accident. According to them such knowledge was mainly acquired through school-related sources such as text-books, teachers, school assignments, etc. Despite that, the media (press and TV) also stands as a source of such information for half of them. These results can be understood in the sense that radioactivity related information may be present in discussions across different disciplines during school (see section 6.2.1). Other sources mentioned were family and radio. Chart 6.9 refers to the answers given by students who reported themselves as possessing some kind of previous knowledge on the subject. In this question, the ratio between total number of choices and number of students for each group is as follows: PS=2.3; MS=1.4; NS=1.5, which indicates that the knowledge that a private school group student claimed to possess comes, in general, from more than only one source.

<sup>3</sup>This will be true for all the subsequent charts presented but for chart 6.18.

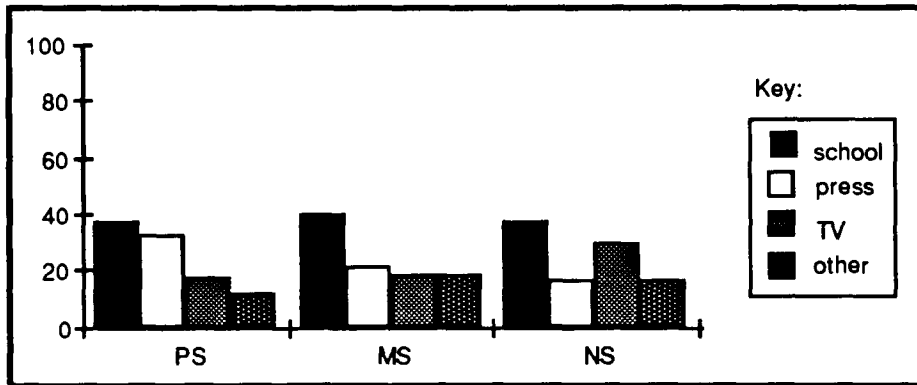

Chart 6.9: Breakdown for options to question: "Where did you get information about radioactivity before the accident?" (percentages calculated over the number of choices for any option)

When asked whether they had sought for information about radioactivity after the accident half of the subjects said they had and half said they had not. Sources mentioned by those who did were school-related sources followed by home and parents. This pattern of choice remains unchanged for the question about where information was actually found, with TV being perhaps the only exception, as more students report having found information on TV. This can be explained if we consider that before the accident information on the subject is likely to have been incidental and episodic and not comparable in quantity to the massive reports present on TV in the weeks which followed the accident. The same is likely to have been true for newspapers and magazines but for the nature of the information actually published, which tended to be more descriptive and concentrating on the circumstances related to the accident. It is interesting to notice, however, that, in all groups, school related sources were mentioned as those students turned to, when seeking for information. These results are shown in charts 6.10 and 6.11, the inspection of which suggests a similar pattern of choices across different school groups. Other sources mentioned in responses to both questions were radio and friends. Again the relative number of choices differ for the three groups. With reference to seeking information, the private school group seems to have had a greater opportunity of consulting more than one source as compared to students from the other groups (PS=1.8; MS=1.0; NS=1.0). This is also true for the case of finding information, for which case the ratios are: PS=2.3; MS=1.1; NS=0.9.

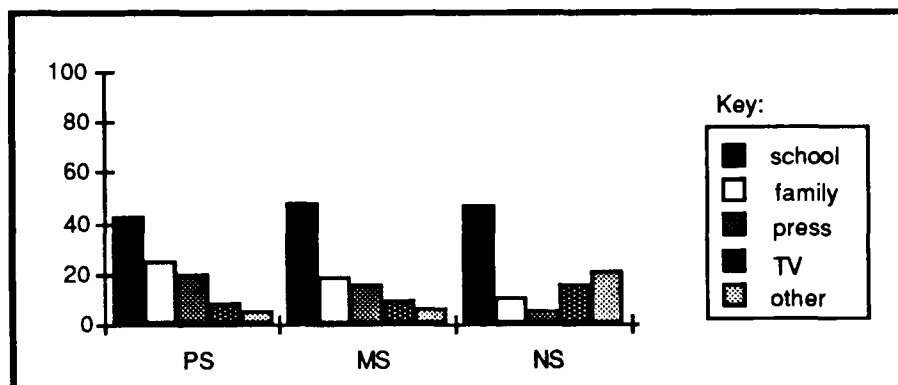

Chart 6.10: Breakdown for options to question "Where did you seek for information?" (percentages calculated over total number of choices made)

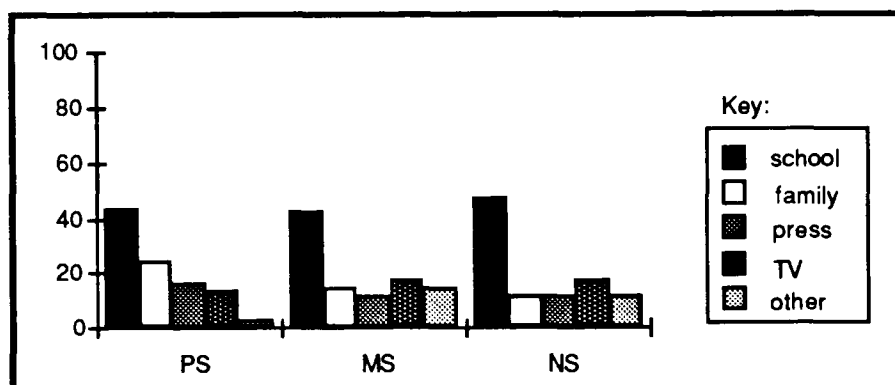

Chart 6.11: Breakdown for options to question "Where did you find information?" (percentages calculated over the total number of choices made)

It is possible to see, quite consistently across the three previous questions, that, although the patterns shown in charts 6.9, 6.10 and 6.11 appear to be rather similar, they actually mean different things as far as individuals' choices are concerned. In fact, an inspection of the relative number of choices made by each group reveals that school related sources have a stronger weight for both morning and night shift public school groups as a source of reliable information.

Some information on how people see themselves in relation to this kind of knowledge as well as their opinion about who would be knowledgeable in the subject was also asked for. It can be noticed from charts 6.13 and 6.14 that the totals for the question "Who should know..." tend to exceed the totals for the question "Who actually knows..." except for those who already know about it, like scientists. What is perhaps more striking, however, is that, in all groups, a large majority say that, in principle, everyone should know about radioactivity and that it

is mostly people who have a specific knowledge of relevant subjects who are considered experts.

However, if one wants to discuss the meaning of these results further a point has to be made about the fact that, in both questions, students were able to tick more than one option. In the case of the question "Who should know about it?" a weak formulation which put inclusive alternatives generates three possibilities of answering which were equally problematic. They are: only the alternative "everybody" was ticked but by students who meant all others or; all alternatives were ticked except "everybody"; or thirdly, all alternatives could be ticked. What actually happened was that they divided between these three possible ways of answering the question, with morning shift school students showing, perhaps, a preference for the third one. This may be one reason why, for both public school and night shift students there seems to be a contradiction namely that the fact that the score obtained for the other options is, in fact, low when compared to the one obtained by the option "everybody". This difficulty, however, does not apply for the case of the question about "Who actually knows about it?" because of the alternatives presented.

Bearing all this in mind, it is still possible to try to speculate about students' choices. Clearly, students seem to be very selective regarding their opinion about who the experts are, though emphasising everyone's right to know more on the subject. People who should know about it are, in their opinion, professionals who are likely to deal with radioactive sources, for example, scientists and doctors, as opposed to professionals who would deal with "processing information" such as journalists who might inform the population about the subject. It is possible to understand this if we consider that journalists themselves have to rely on expert opinions before doing their job.

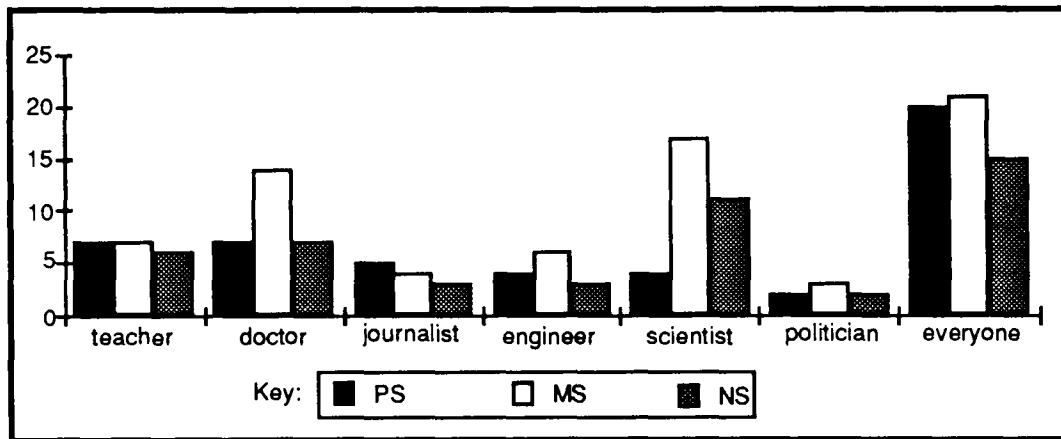

Chart 6.12: Breakdown for options to question: "Who should know about radioactivity?" (figures shown are actual number of choices).

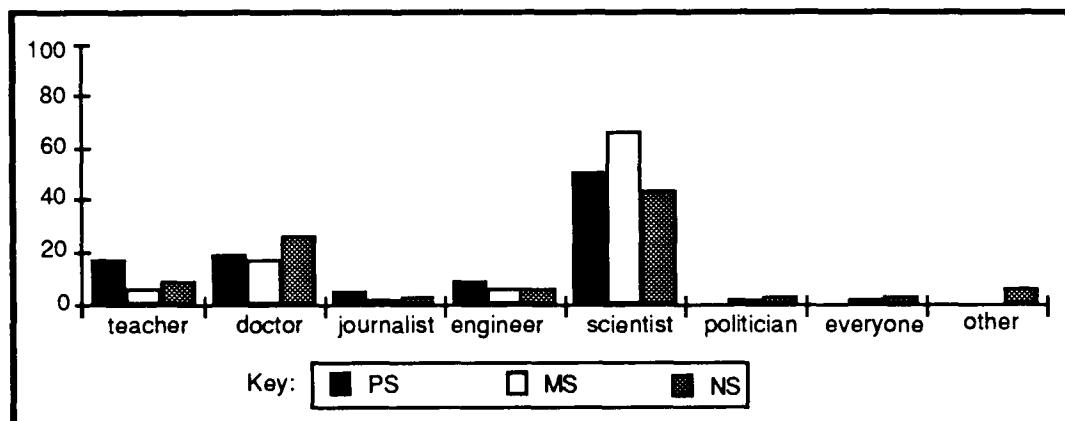

Chart 6.13: Breakdown for options to question "Who actually knows about radioactivity?" (percentage calculated over total number of choices made)

#### 6.2.3.1.4 Self-Evaluation of Own Interaction with Related Information

Perceptions of kinds of information available at the time of the accident are shown in the chart below. Almost half the answers have to do with specific information about the event itself while about a third reflect a preoccupation with possible consequences of exposure to ionising radiation. Scientific explanations of the nature of radioactivity account only for a small minority of the answers. It is possible then to speculate whether students' answers split in two groups: one concerning factual information and another related to explanatory accounts.

In fact if one returns to the time of the accident in order to analyse the kinds of articles published at the time it is possible to see that they concentrated on explaining the event and discussing its possible consequences (see chapter 4, Section 4.3.2). Only a few reports included some supporting scientific information which was thought necessary to understand the facts. Chart 6.14 summarises all this and shows not very similar patterns of choices for the three groups. The relative numbers of choices, in this case is: PS=1.5; MS= 1.3; NS=1.6 revealing that, in this case, none of the groups appears to make more than one or two choices. However, it is possible to speculate about the night shift group presenting a greater preference or a stronger perception for contextualised information (like that involving real events, as accidents)

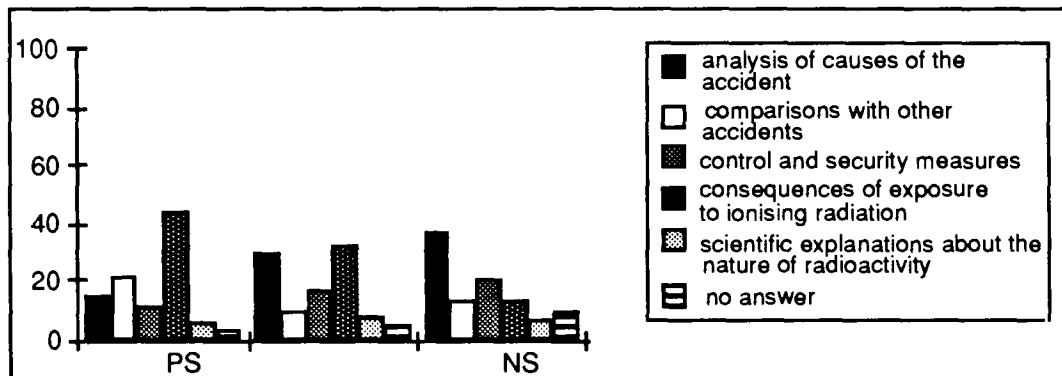

Chart 6.14: Breakdown for answers to question "Most of the information you got at that time related to..." (percentages calculated over total number of choices made)

Reasons given for seeking this information were mainly related to understanding better the process of radioactive contamination for almost half of the subjects, while nearly a third wanted to clarify their own ideas and doubts on the subject. Thus, the majority of the answers had to do with specific personal concerns related to security and possible effects, by contrast with the option "curiosity" which was chosen by only one student.

Considering that students' reasons for looking for information were strongly influenced by a motivation of understanding both the accident itself and its consequences, leads one to think that a comment that is perhaps worth making is the importance attributed to information in context. It is not knowledge "per se" which is regarded as important but instead, knowledge as applied to a specific context in order to describe, explain or solve a given problem.

The answers given by different school groups can be seen in chart 6.15 which shows that private school students' and morning shift public school students' reasons seem to show a greater degree of similarity between each other, in so far as they appear to be more diversified, as compared to night shift public school students'. However, in all groups, a number of students did not answer the question at all, as shown by the relative number of choices which are: PS=0.7; MS=0.6; NS=0.4.

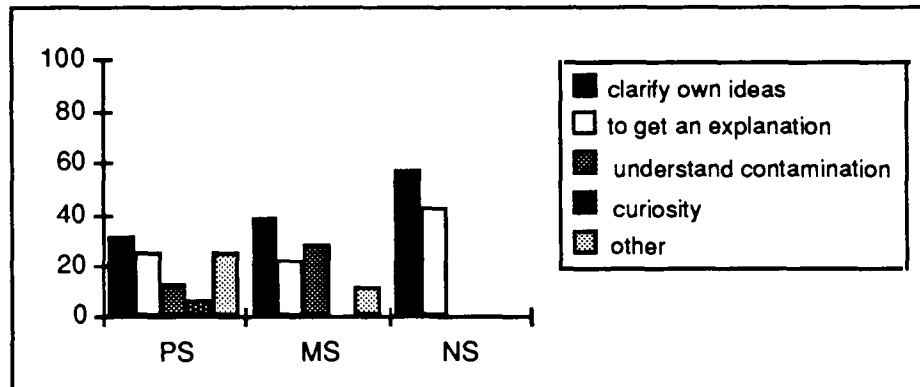

Chart 6.15: Breakdown for answers given to question "What were the reasons for seeking for information?" (percentages calculated over the total number of choices made)

About three quarters of the subjects admitted not having understood information they had contact with in one or another aspect, with private school students being more critical towards their understanding. Among outstanding doubts half of the subjects mentioned aspects of scientific explanations about the nature of radioactivity, with fewer choosing the remaining options. Nevertheless if counts for these options are added they exceed the figure corresponding to "scientific explanations about the nature of radioactivity". In other words, more than half of the subjects report having doubts about factual information which might indicate that both factual and explanatory accounts they might have found were not well understood. Chart 6.16 presents answers given by each group and suggests that there is no striking difference in the patterns of answers given. In addition, relative number of choices are similar for all groups (PS=0.9; MS=1.0; NS=0.9). It is worth emphasising that this question was answered only by those who ticked "yes" to the question on having or not having doubts at that time.

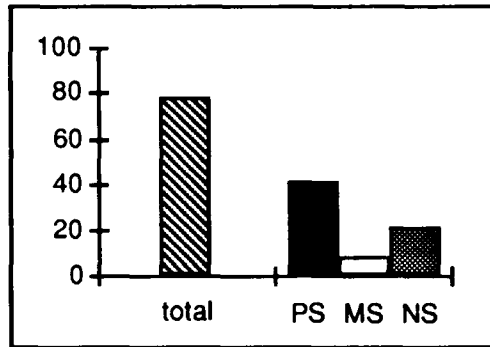

Chart 6.16: Totals and breakdown for 'yes answers' to "Were there things you did not understand at that time?"

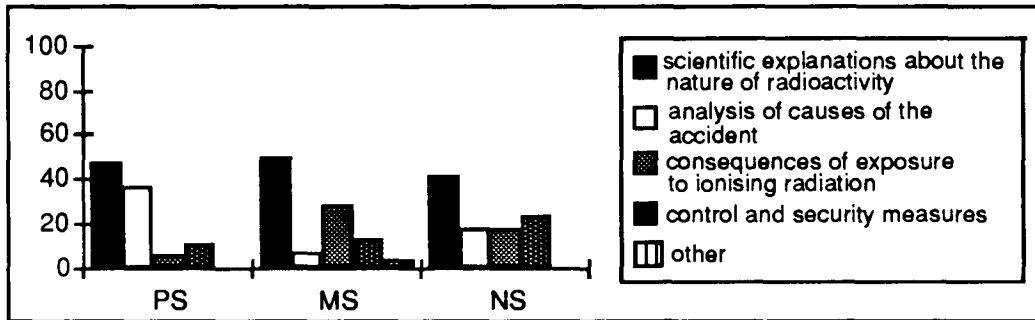

Chart 6.17: Breakdown for answers to question "Things you did not understand at that time relate to..." (percentages calculated over the total number of answer given to each option)

When asked explicitly about the kinds of information which were actually helpful as far as an understanding of the events was concerned, more than a third of the students emphasised that medical information about the consequences of exposure to ionising radiation proved to be helpful. This was followed by scientific information about the nature of radioactivity and causes of the accident in approximately a quarter of the answers. However, this pattern changes for the question about kinds of information that would have been helpful. In this case, half of the students report they feel that scientific information about the nature of radioactivity *would* have helped. Less than a quarter wanted medical information about consequences of exposure to ionising radiation and only a minority mentioned the remaining options. These results are shown in chart 6.18 and suggest that, in general, students are not able to discriminate between different types of information in so far as they were thought to be useful in helping them to understand about radioactivity. They might also indicate that the information they got, in particular that concerning the "nature of radioactivity, was not properly understood and that, because of this, they would have liked to have more of it. For



the two questions, the relative number of choices are very similar for all groups (PS=1.2; MS=1.1; NS=1.0, for the question about information which proved to be helpful and PS= 1.4; MS= 1.2; NS= 1.1, for the question about information which would have been helpful).

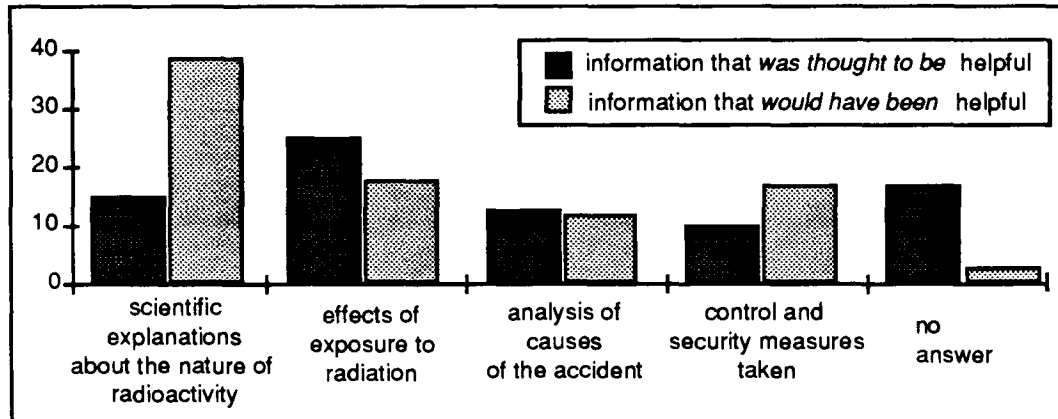

Chart 6.18: Totals for questions "Information which proved to be helpful..." and "Information which would have been helpful..." (figures are actual counts)

Charts 6.19 and 6.20 show the breakdowns of answers given by each school group. It seems to be the case that private school students tend to discriminate more among the options than both morning and night shift public school students in the case of evaluating information that proved to be helpful. With respect to their evaluation of types of information which would have been helpful the patterns of answers given by groups do not show any striking difference apart from, perhaps, the fact that night shift students judged that information concerning the causes of the radiological accident of Goiânia would have been of help, by contrast with both private school and morning shift public school students, who did not show any special preference for this option. On the other hand there is an agreement among subjects from all groups, in particular of the private school group, that "scientific information about the nature of radioactivity" would have been helpful, which is consistent with the fact that most of them report not having understood this kind of information at the time of the accident (see Chart 6.17). In this case the relative choices were, again, very similar for the three school groups (see paragraph above).

THE PILOT STUDY

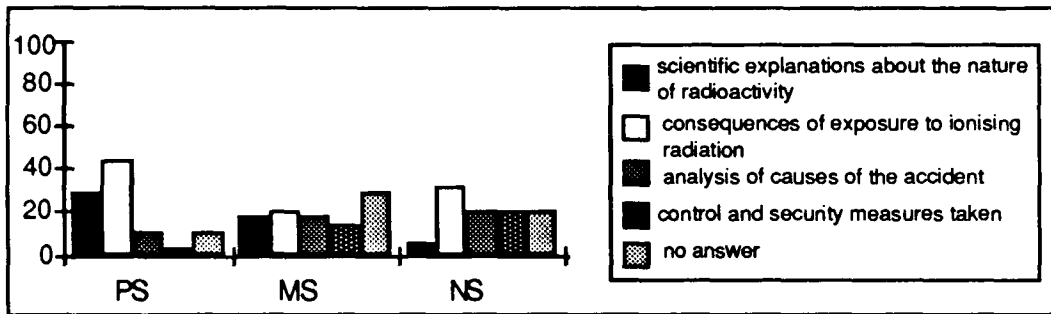

Chart 6.19: Breakdown for question "Information which proved to be helpful..." (percentages calculated over the total number of answers given)

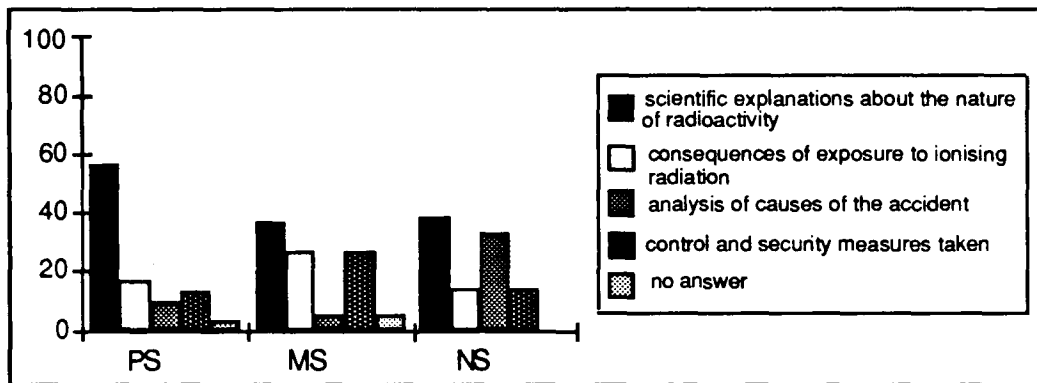

Chart 6.20: Breakdown for question "Information which would have been helpful..." (percentages calculated over the total number of answers given to each option)

Nearly all subjects in all groups reported that there are aspects they still do not understand which, for all groups, relate mainly to the nature of radioactivity. This pattern is similar to the one shown in chart 6.10 which refers to doubts people had in relation to the subject, at the time of the accident. That comparison suggests that students do not feel that any information they got has substantially improved their knowledge.

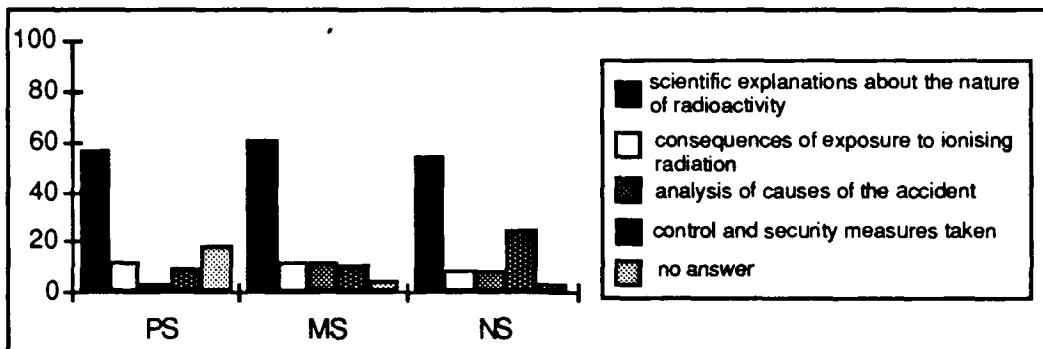

Chart 6.21: Breakdown for answers to question "Things you still do not understand relate to..."

### 6.2.3.1.5 Specific Knowledge held by Students

Students were asked to exemplify some of the questions about radioactivity that they would wish to have answered. Most questions concerned the nature of radioactivity. Examples of such questions are: *"What is it?"*, *"Where does it come from?"*, *"How long does it last for?"* *"Is it natural or artificial?"*. These were followed by questions about what can be done to avoid or control effects of exposure to ionising radiation, such as: *"How can we protect ourselves from radiation?"* *"What were the security measures taken at the time of the accident?"*, *"Is it possible to recover from exposure to ionising radiation?"*, *"Is it possible to decontaminate an area in a few hours?"*. Many questions also concerned risks associated with its uses and technological applications. For example, *"Why do we have to live with such a menace?"*, *"Why is it still produced, if it is so dangerous?"*, *"Why create and use something that can destroy all mankind?"*.

Students were also asked whether they knew anything about some of the applications of ionising radiation as well as its continuity with other types of radiation. The question was phrased as "Have you ever heard ...? (a) that ionising radiation is used in the treatment of cancer?; (b) that ionising radiation is used to sterilise food?; (c) that the light emitted by the sun is an example of radiation? and ; (d) that there are places, like Guarapari, where there is a high level of natural radioactivity?."

More than half of the students in total said they knew about uses of radiation to treat tumours. Results were similar for all groups, with no appreciable differences between them. Only a small minority answered 'yes' as to whether they knew that irradiation is used to sterilise food in all three groups. This particular use of ionising radiation was actually the least known by students. Nearly three quarters of the respondents in each group perceived that solar radiation and ionising radiation had, in principle, the same nature. About a third of the total number of students knew of 'natural radiation'. Again there were no appreciable differences between the groups, though rather fewer students from the morning shift group claimed to have heard about this fact.

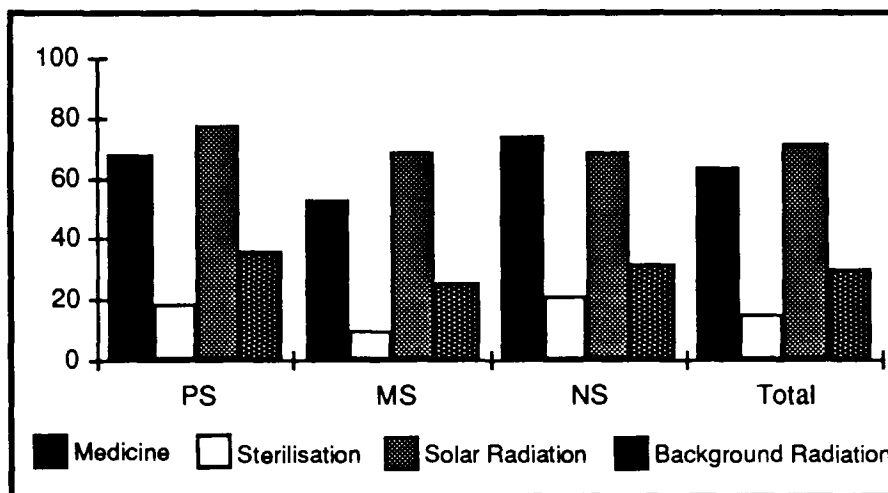

Chart 6.22: Total and breakdowns for percentages of 'yes answers' to question: "Have you ever heard of ...?"

### 6.2.3.2 Summary of Results Concerning Sources of Knowledge

The results can be summarised in four main points:

(i) students' accounts tend to be lacking in detail and coherence, even for students who say that they remember quite well what happened in Goiânia, which is consistent with the fact that most of their knowledge was acquired through the media and not from school related sources.

(ii) students' say they do not know very much about the topic though they would wish to know more, especially through "schooled" sources. That relates to the fact that in the questions "Who actually knows about radioactivity?" experts are thought of as the only source of reliable information. In this sense, school related sources can be seen, perhaps, as the closest students could get to experts' accounts.

(iii) it appears to be the case that most of the responses given to questions about evaluating own understandings of different types of information can be interpreted as if students were, in different contexts, re-stating that they could not comprehend most of the information they had contact with, in particular, scientific explanations about the nature of radioactivity. However, the questions asked do not go as far as

providing suggestions about the nature of these difficulties although they bring out their existence.

(iv) students still possess outstanding doubts about radioactivity. These are related to aspects concerning its nature, about control and precautions that are necessary when dealing with radioactive materials and about the risks and hazards associated to its technologies.

(v) there seems to exist a preference from students from all groups for contextualised information, that is, for information which bears a strong relation to actual real-life events or circumstances.

In so far as differences between the groups are concerned, it is possible to speculate about private school students relying more on previous knowledge in response to some questions, like, for example, being able to evaluate risks. Apart from that the private school students tend to provide more detailed and complete accounts of the event and of the circumstances involving the radiological accident of Goiânia, as compared with the others, which may reinforce the assumption of the private school group possessing greater access to information.

### **6.2.3.3 Nature of Knowledge**

Two questions aimed at investigating the nature of people's knowledge. Both questions focus on the conceptualisation of the nature of radioactivity and of the processes through which it works. The responses given to both questions will be discussed separately and later related together.

#### **6.2.3.3.1 "Is radioactivity like...?"**

The first question investigated which kinds of entities are evoked when radioactivity is mentioned. Students were asked "Is radioactivity, in some way, like ...?" each of the entities shown in Table 6.2. These involved concepts in physics, for example,

radio waves, magnetic field and electricity; different types of substances such as gas and water, and objects of daily life experience such as dust and cloud. Students were asked to tick or cross each alternative so that patterns of responses could be found yielding patterns of similarities and differences among entities. Table 6.2 presents an overall picture of the frequency of choices given for each entity.

ENTITIES	OVERALL TOTAL
X-rays	40
M' Field	29
Rays	24
Gas	18
Electricity	14
Light	10
R' Waves	10
Dust	8
Cloud	7
Air	5
Object	2
Water	1

Table 6.2 : Total of "yes" answers given to proposed entities in question "Is radioactivity, in some way, like...?" (N=73)

Although students could tick any number of alternatives, it can be seen that none of the concepts gets a particular high score. "X-rays" represents the choice of about half of the students, followed by "magnetic field" and "rays" each chosen by approximately a third of the students. Light and electricity were mentioned only by a minority and concrete objects and substances were chosen by few indeed.

Chart 6.21 shows the percentage contribution of each school group towards the overall total of each entity. Patterns of choice of the three different groups are similar in the cases of "X-rays", "magnetic field", "electricity" and "light". There may be a slight tendency for private school students to choose physical entities as opposed to night shift public school students to choose substances of ordinary experience, with "object" and "water" being exceptions to this trend.

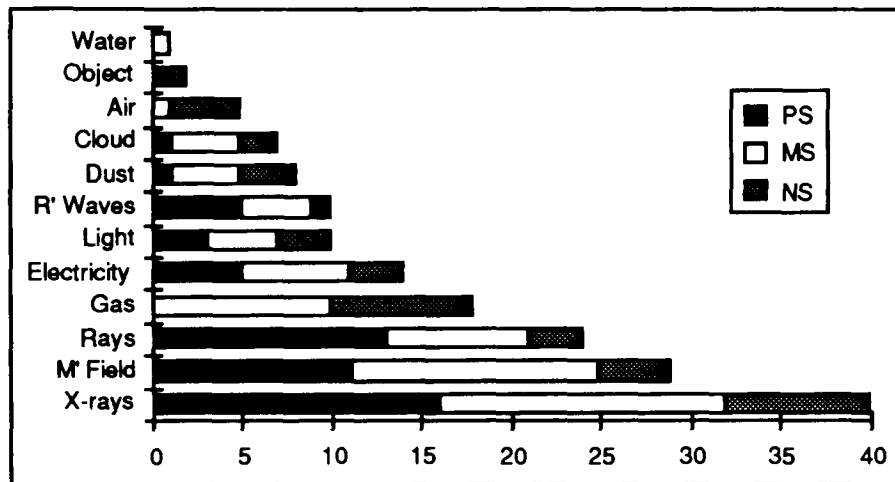

Chart 6.23: Percentage of 'yes answers' for each entity for each school group.

These associations may have been influenced by some knowledge about effects of radioactivity. For example, the high frequency of responses given to the item "X-rays" may lead us to consider whether this arises from knowledge of medical uses of radiation. Another tentative interpretation of the results is that the associations with concepts which are not best understood as part of daily life experience may suggest that radioactivity is regarded as something remote and not so simple to understand. For example a magnetic field might, in this sense, share with radioactivity the properties of being both intangible and complex in nature as opposed to water which presents a more familiar and predictable behaviour across different contexts. Thus it is possible to think about the choices made as if they are split into two groups: concrete objects familiar to ordinary experience and, at another extreme, abstract intangible entities which are more commonly found in physics text-books.

One could object that the entities presented already embody such a distinction. However, the question asked is not how the entities resemble one another or not, but how each resembles radioactivity. Thus the distinction is about radioactivity and not about the entities.

To examine data in terms of possible underlying features, multidimensional scaling was used. The proximity matrix was obtained through the calculation of the correlations between the responses on each entity. As explained by Everitt & Dunn:

*"a geometrical or spatial model for the observed proximity matrix consists of a set of points  $x_1, x_2, \dots, x_n$ , in  $d$ -dimensions (each point representing one of the items or stimuli under investigation) and a measure of distance between pairs of points. The object of multidimensional scaling is to determine both the dimensionality of the model... and the position of the points in the resulting  $d$ -dimensional space, so that there is, in some sense, maximum correspondence between the observed proximities and the interpoint distances." (Everitt & Dunn, 1983, p. 53)*

The fit using the ALSCAL method has a stress of 0.166 and a RQS of 0.829 for two dimensions, which is a fair, but not good, fit, according to Kruskal's rules of thumb (Everitt & Dunn, 1983, p.65). The resulting plot is shown in figure 6.2. (see Appendix 6.3).

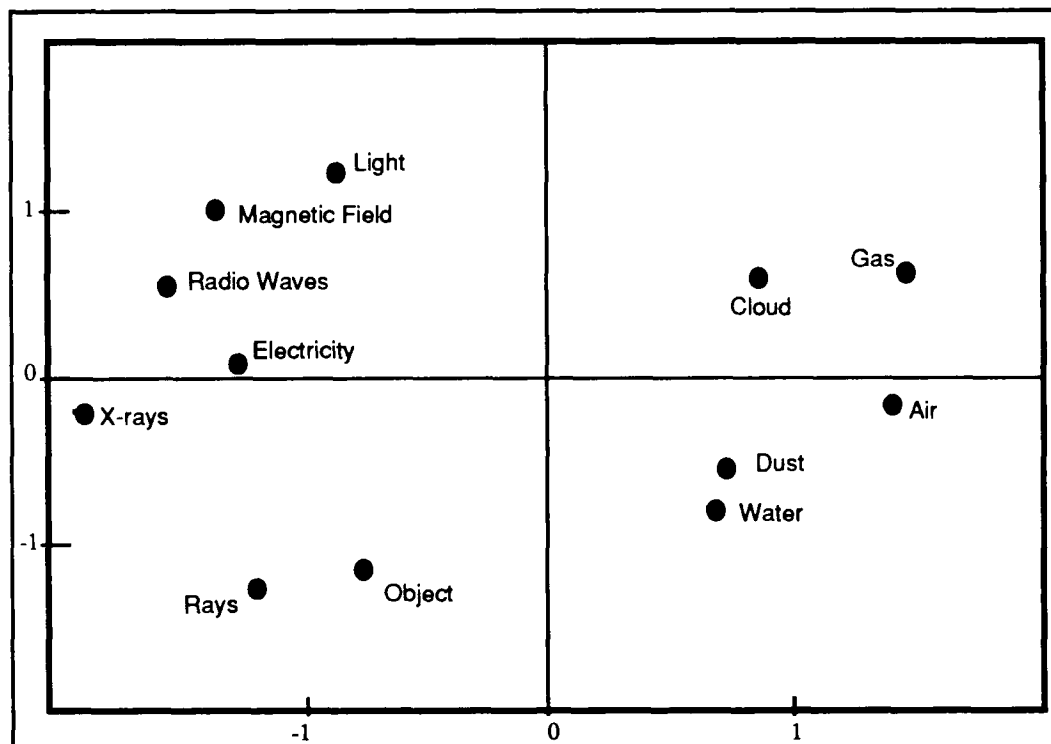

Fig. 6.2: Multidimensional Scaling plot for question "Is radioactivity, in some way, like..."

With the exception of "object", the horizontal axis looks like a distinction between 'material' and 'immaterial' entities. Thus "cloud", "gas", "air", "dust", "water", all lie at one end with "light", "magnetic field", "radio waves", "electricity" and "x-rays" at the other. The vertical axis is harder to interpret, but could be a distinction between 'located' or 'discrete' entities ("object", "water", "rays", "dust") and 'dispersed' or 'continuous' entities ("gas", "light", "magnetic field"). These interpretations are far from secure, however. Because most of the material entities



are also passive, and the immaterial ones mostly active, dimension 1 could also be 'passive' versus 'active'. More entities would be needed to resolve such differences in interpretation.

Due to the limited number of points, it was not possible to re-do the analysis for the case of three dimensions. Nevertheless the proposed interpretation for the two dimensions are consistent with the responses given and, as will be reported later, with the results of other questions.

#### **6.2.3.3.2 Properties Attributed to Concepts**

In Question 2, students were asked to evaluate the concept of radioactivity in terms of nineteen properties presented on bi-polar five point scales. That is, nineteen pairs of opposite possible properties which could apply to radioactivity were presented as dimensions along which it should be considered. These properties related broadly to its nature and to its interactions with matter, and are shown in Table 6.3.

Choices were scored on a scale of 1 to 5. To have a uniform representation, scores whose mean was less than 3 were reversed (subtracted from 6), that is, in effect, always assigning the scale point 5 to the most frequently chosen pole. The most frequently chosen poles are shown in capitals in Table 6.3. Thus a score near 5 indicates a strong perception of radioactivity as like the most selected pole, whereas scores near 3, now the minimum possible, reflects a more equal preference for the two poles.

These judgements are those of a group, not of individuals. We can therefore also ask how far the group concur in their judgements. That is, any mean score can be obtained either by most subjects choosing that scale point, (concurrence), or by their choosing opposing poles in proportions which lead to that mean score, (lack of concurrence).

In figure 6.3, response patterns are arranged vertically in order of the polarisation of responses (tendency to agree with one pole). They are arranged horizontally, with the patterns showing the greatest dispersion on the left and least dispersion (greatest degree of concurrence) on the right.

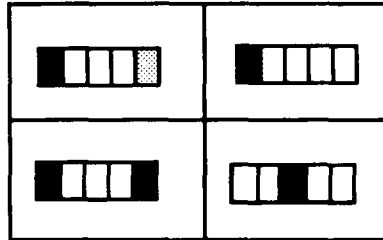

Fig 6.3: Patterns of answers in the RevMeans X Concur plot

In figure 6.4, the vertical axis (polarity) is just the (reversed) mean score. The horizontal variable 'concur' is derived from the standard deviation,  $\sigma$ , of the scores. Since the maximum possible standard deviation,  $\sigma_{\max}$ , is a function of the mean score, the variable 'concur' is defined as  $1-\sigma/\sigma_{\max}$ . It is shown in appendix 6.2 that

$$\sigma_{\max} = \sqrt{(m-1)(5-m)}$$

where  $m$  is the mean score on a scale from 1 to 5.

Thus, in figure 6.4, in the top left hand corner are dimensions on which judgements were strongly polarised though students do not show a high level of concurrence among themselves. The top right hand corner also indicates polarisation, but in this case the group concurs. Cases in which the group tends to be undecided between the two extremes of the scale are shown in the bottom left hand corner while cases where a highly consistent preference for the middle point occur are shown in the bottom right hand corner.

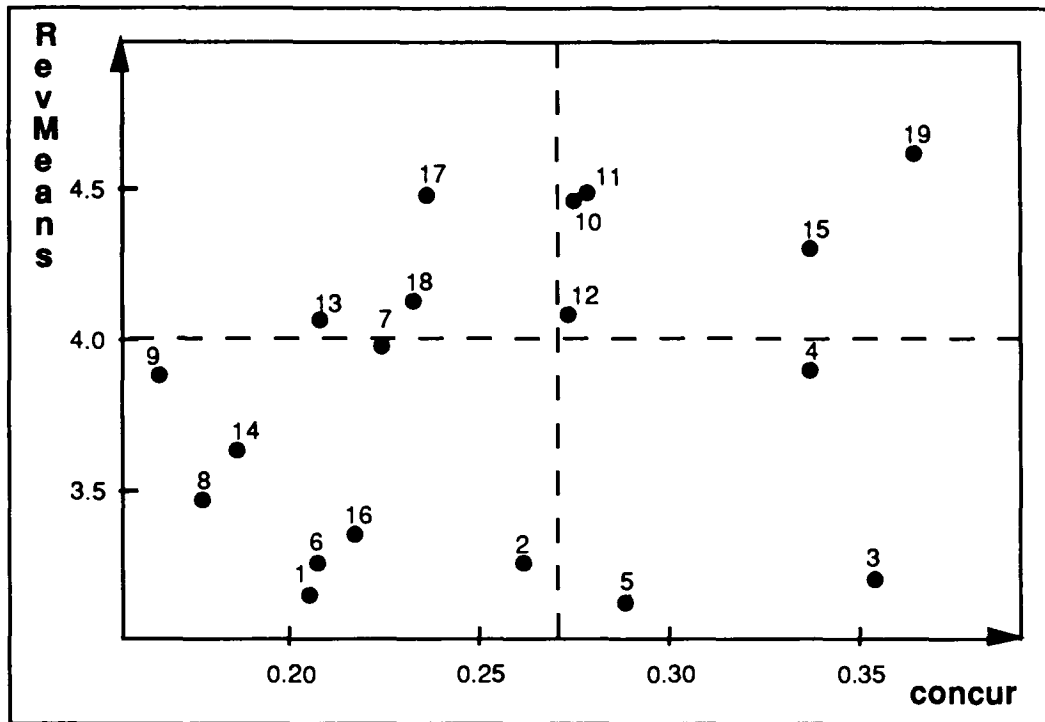

Fig 6.4: Reversed Means vs Concur plot (see table 6.3 for identification of codes)

The key for figure 6.4 is shown in Table 6.3.

Key

NUMBER	PROPERTY
1	lasts forever X <b>DIES AWAY WITH TIME</b>
2	exists in nature X <b>IS MADE ARTIFICIALLY</b>
3	passes through objects X <b>is blocked by some objects*</b>
4	<b>CAN BE ABSORBED</b> X can be reflected
5	grows by itself X <b>HAS TO BE MADE</b>
6	<b>CAN BE DIVIDED INTO PARTS</b> X can be divided into parts
7	is static X <b>MOVES</b>
8	is not material X <b>IS MATERIAL</b>
9	<b>CANNOT BE LOCATED IN SPACE</b> X can be located in space
10	<b>IS MADE OF PARTICLES</b> X is not made of particles
11	<b>ACTS UPON BODIES AROUND IT</b> X does not act upon bodies around it
12	<b>ACTS BY CONTACT</b> X does not act by contact
13	does not act at a distance X <b>ACTS AT A DISTANCE</b>
14	is not affected by bodies around it X <b>IS AFFECTED BY OBJECTS AROUND IT</b>
15	<b>DESTROYS THINGS</b> X creates things
16	<b>ACTS BY ITSELF</b> X is set in action by something else
17	is created from nothing X <b>IS CREATED FROM SOMETHING</b>
18	cannot be kept safe X <b>CAN BE KEPT SAFE</b>
19	<b>MAKES OTHER BODIES RADIOACTIVE</b> X does not make other bodies radioactive

Table 6.3: Evaluative dimensions presented in Question 2. (capital letters indicate most strongly chosen pole); \* strongest preference for centre point of the scale.

In figure 6.4 the more strongly selected poles are those represented by the points above the horizontal dotted line. If points 4 and 9, which are slightly below this line are included as part of this set, the general picture of students preferences is that radioactivity is something *active*, perhaps *material* and that "*can be managed*". It is thought to be able to act upon bodies around it both by contact and at a distance so as to make them radioactive too. It also moves and destroys things. It is like particles that can be located in space and which are created from something. It can also be absorbed and kept safe.

Judgements which fall between the two poles correspond to points below the horizontal dotted line (with exception of points 4 and 9). They relate mainly to a possible autonomous character (*grows by itself vs has to be made; acts by itself vs is set in action by something else; is not...vs is affected by bodies around it; passes through object vs is blocked by objects*), to its natural existence (*exists in nature vs is made artificially*) and a particulate nature (*is not... vs is material; can be divided vs cannot be divided; lasts forever vs dies away with time*). This picture is consistent with the features exposed in the previous paragraph which indicated an ambiguity between something described as active which can, somehow, be managed or controlled. It also throws some light on the question of its materiality by suggesting it may be considered to be more like a substance.

It can be seen that the group do not concur in most of the cases where there was not a strongly preferred pole. The only two of these cases where the group strongly concur are "*grows by itself vs has to be made*" and "*passes through... vs is blocked by objects*" as they all agree radioactivity can have both properties in each case. With respect to the dimensions where there is a preferred pole, the feature the group most concurs about is radioactivity's active destructive character, as illustrated by their choices that it makes other bodies radioactive, of its destructive power ("*can be absorbed...*"; "*acts upon other bodies*"; "*acts by contact*") and that it is made of particles.

As it happens the pole they most strongly prefer, and about which they most concur, is "*makes other bodies radioactive*", is considered to be wrong from a scientifically accepted point of view. There is also an ambivalence in the properties attributed to radioactivity, in as much, for example, as they say that it is like located particles which act at a distance. This suggests that the concept of radioactivity is

being seen as some *combination of radioactive material and radiation*, which is consistent with results presented in the literature (Eijkelhof & Millar, 1988). Another ambiguity relates to the fact it is moving and active but can, somehow, be managed, as expressed by the choices "*moves*", "*acts upon bodies*" as compared to "*can be kept safe*", "*is affected by bodies around it*". However to what extent the notion expressed by the latter should be associated with the notion of shielding is not clear because the way it affects things is basically *changing its nature*, that is, modifying bodies' structure and properties ("*it can be absorbed*", "*makes other bodies radioactive*", etc).

As could have been expected, dimensions whose choices are divided between the two extremes lie in the bottom left hand corner of figure 6.4, close to the vertical axis. Inspecting these dimensions it is possible to see that their very formulation present adjectives which are mutually exclusive, instead of complementary in meaning, at the extremes of the scale so that the choice of the central scale point is not sensible. This fact is acknowledged as a problem and was taken into consideration as far as the design of the questionnaire to be used in the main study is concerned.

With respect to differences between the groups it can be said that the choices of students from the three different groups tend, in general, to be similar. Some slight differences can be found, for example, in the case of the dimension "*grows by itself vs has to be made*" with the private school group more often saying it has to be made and in the case of dimension "*is not... vs is material*". In this case, private school students' choices are uniformly distributed along the five point scale whereas the morning shift public school group seems to be undecided between the two extremes of the scale; only the night shift group revealed a preference for "*is material*". Finally, although as a single group students do not agree whether radioactivity "*lasts forever*" or "*dies away with time*", within the three subgroups there is a consistent pattern of agreement with most of the private school students saying it "*dies away with time*" by contrast with most of the night shift group, who believe it "*lasts forever*"; while the majority in the morning shift group admits both possibilities.

In order to be able to see whether these results can be discussed in terms of more general features a Factor Analysis was carried out to look for underlying

relationships between the variables. Orthotran/Varimax solution gives eight factors whose loadings are shown in Table 6.4.

Before one goes any further with the interpretation of the factors, it is important to point out that this factor analysis cannot be regarded as giving a simple and clear-cut reduction of the data. Were the variables not associated at all except for random correlations, one would expect a number of factors approaching the number of variables, with no real reduction of the dimensions of the space. However, in the analysis of such a set of variables the Bartlett sphericity test should fail to reject the hypothesis of no structure. Factors should be uninterpretable except as reflecting a single variable. In the present case, the Bartlett sphericity test gives  $\chi^2 = 242.2$ , with 189 degrees of freedom and  $p=0.005$ .

There is some reduction in the dimensionality of the space, from 19 to 8. The most reasonable position seems to be tentatively accept the factor analysis as meaningful, but to rely on the factors having natural interpretation. Thus the value of the interpretation will depend in the factor analysis being interpretable, and on the interpretation being consistent with data collected in other questions.

Factor 1 has its highest loadings in dimensions *"cannot be... vs can be located"*, *"is made... vs is not made of particles"*, *"acts... vs does not act upon bodies around it"* and, negatively, *"static vs moves"*. It seems to be related to an active character or being or not made of particles. The negative sign indicates that these are mutually exclusive. Factor 2 is about being able or not to act by itself, acting at a distance or not and being absorbed or reflected. *"Makes other bodies radioactive"* and *"grows by itself vs has to be made"* are the two dimensions with the higher loadings for factor 3. Factor 4 brings together *"cannot be vs can be kept safe"*, *"acts... vs does not act by contact"* and *"passes through... vs is blocked by some objects"*. *"Is created from nothing vs ...something"*, *"is not... vs is affected by bodies around it"* and *"exists in nature vs is made artificially"* are the dimensions which aid interpretation of factor 5. Factor 6 is characterised by high loadings on dimensions *"can be... vs cannot be divided into parts"*, *"exists in nature vs is made artificially"*, *"is static vs moves"* and *"acts... vs does not act upon bodies around it"*. Factor 7 relates to being material or not and to acting upon bodies around it or not. Finally *"lasts forever vs dies away with time"* and *"creates things vs destroys things"* are the dimensions which possess the highest loadings for factor 8.

THE PILOT STUDY

DIMENSION	FACTOR LOADINGS							
	Factor 1	Factor 2	Factor 3	Factor 4	Factor 5	Factor 6	Factor 7	Factor 8
lasts forever X DIES AWAY WITH TIME	-.092	.349	.029	.153	-.053	.069	-.011	.758
exists in nature X IS MADE ARTIFICIALLY	.067	-.072	-.015	-.056	.496	.604	.151	-.059
passes through... X is blocked by objects	-.175	-.204	.477	.379	.005	-.171	.217	.020
CAN BE ABSORBED X can be reflected	.064	-.802	-.096	.114	.007	.065	.033	.033
grows by itself X HAS TO BE MADE	.292	.100	.621	.142	-.033	-.103	.094	.200
CAN BE... X cannot be divided into parts	-.101	-.110	.045	.057	-.131	.751	-.185	-.049
is static X MOVES	-.562	.192	-.275	-.071	-.058	.367	-.157	.233
is not... X IS MATERIAL	-.151	.000	.047	.018	.000	-.143	.879	-.092
cannot be.. X CAN BE LOCATED IN SPACE	.723	.188	-.117	-.044	.045	-.112	-.022	-.104
IS MADE... X is not made of particles	.736	-.089	.114	.058	-.018	.084	-.030	-.035
ACTS... X does not act upon bodies around	.572	-.123	.033	-.103	.043	.357	.482	.275
ACTS... X does not act by contact	-.154	-.097	.230	-.746	.063	-.015	.076	.067
does not act... X ACTS AT A DISTANCE	.174	.477	-.093	.277	-.289	.095	.210	-.012
is not... X IS AFFECTED BY BODIES AROUND IT	.066	.048	.262	.064	.677	-.058	-.073	-.210
creates things X DESTROYS THINGS	.097	.317	-.213	.238	.042	.191	.072	-.693
ACTS BY ITSELF X is set in action	.009	.617	.047	.066	.335	-.248	-.114	.253
is created from nothing X... SOMETHING	-.008	.022	-.374	-.046	.730	.029	.071	.134
cannot be ... X CAN BE KEPT SAFE	-.106	-.039	.186	.776	.058	-.094	.026	.040
MAKES... X does not make bodies r'active	-.056	.126	.713	-.307	.008	.266	-.122	.039

Table 6.4: Factor loadings from Factor Analysis of Question 2

Factors were interpreted as follows:

FACTOR	INTERPRETATION
Factor 1	Moving particles
Factor 2	Autonomous action
Factor 3	Action on matter
Factor 4	Able to escape
Factor 5	Natural existence
Factor 6	Particulate nature
Factor 7	(Im)material influence
Factor 8	Permanent non-destructive

Table 6.5: Interpretation of Factors

The factors were largely orthogonal though factor 2 and factor 4 have a small correlation (0.277). In the present analysis the factors are used so as to identify possible ways in which different questions can be grouped.

In the interpretation of the results of this factor analysis, factors will be considered as dimensions along which students may be thinking about radioactivity. These

dimensions are mainly related to its nature (moving particles, natural existence, immaterial influence), to its active power (action on matter, (im)material influence, permanence) and to processes through which this action occurs (autonomous action / able to escape). The factors indicate that the nineteen evaluative dimensions presented group in this way, that is, that relevant dimensions can be understood as relating to *nature*, *action* and *process*. The responses, however, indicate ambivalences and ambiguities in the properties radioactivity is thought to have. As it was pointed out earlier, students appear to be thinking of radioactivity as a combination of the concepts of radiation and radioactive material. This can be understood if one remembers that radioactivity is not an entity but a property of matter and, for this reason, many of the distinctions presented would not apply. However, it is not possible, from the results presented here, to establish whether students actually made such distinction between entities and properties or whether the results merely exemplify the well known undifferentiation between the concepts of radiation, radioactivity and radioactive material. In either case, dimensions along which they appear to be thinking about it are those which depict problematic aspects of the concepts mentioned. These aspects are: the dual nature of radiation (wave-like and corpuscular), the effects of its interaction and the process through which it interacts with matter.

However, it is not until the actual polarity of the choices are considered that it is possible to say what students might actually be thinking along these dimensions represented by the factors.

#### **6.2.3.3.3 Summary of Results Concerning Nature of Knowledge**

A general picture of students responses seems to be as follows: radioactivity is like moving particles, with a strong destructive power, but they are not sure of whether or not it possess an autonomous character and they disagree whether it exists in nature or is made artificially. They do not express a consensual view as to whether it is material or not, which is in conflict with their answer that it is made of particles and illustrates the ambivalence described in the previous section.



The results of question 2 are consistent with those expressed in question 1 ("Is radioactivity, in some way, like...?"). Recapitulating, one of the dimensions obtained through the multidimensional scaling for question 1 relates to materiality while the other could be interpreted as a distinction between localised and dispersed or active and passive entities. The factors obtained not only embed these two aspects, namely action and materiality, but also suggest other possible features of students' thinking. For instance, one could, inspired by factor 5 (natural existence), speculate about dimension 2, in the multidimensional scaling done for question 1, to be interpreted as a distinction between concrete objects which exist in nature and objects which are, in fact, abstract concepts related to man-made artifacts.

In summary, the analysis of both questions 1 and 2 suggests that:

(i) there seems to be an ambivalence in the associations of radioactivity with both material and immaterial entities;

(ii) students' responses indicate the perception of radioactivity as active, destructive and intangible as suggested both by the associations made with, for example, "X-rays" and "magnetic field" in question 1 and by the properties attributed to it in question 2.

(iii) it appears to be the case that the degree of accessibility to the senses was a possible way of differentiating entities which could or could not be associated with radioactivity.

(iv) there is a tendency across the different groups to regard radioactivity as made of particles (though students do not agree whether it is material or not, moving, acting upon bodies around it either by contact or at a distance, able to be located in space and destructive. It is absorbed by bodies which are exposed to it which, in their turn, become radioactive too. Yet it can be kept safe.

(v) the ambiguities and contradiction in students' responses across different contexts can be understood if one considers that they might be attributing

properties of other concepts such as radiation and radioactive material to radioactivity.

### **6.3 THE PILOT INTERVIEW STUDY**

#### **6.3.1 THE SAMPLE**

Three pilot group interviews were conducted with six Brazilian non-science professional adults doing post-graduate studies in the United Kingdom. They were all in their late twenties or early thirties and had not studied any science after secondary school. None of them reported having had any specific knowledge on the subject and only one of them was in Brazil at the time of the accident. They were divided in three groups of two, asked to read a text on a radioactivity related topic, namely food irradiation, and to discuss their understanding of the text. After that they were asked to construct a semantic net summarising common points of agreement about their understanding of the text.

#### **6.3.2 DISCUSSION**

The interviews were treated as a pilot exercise, to help design the interviews for the main study. The following relates to general comments on the interview draw implications for the design of the main study.

(a) the text used was an adaptation of an article published in New Scientist about food irradiation. It was considered too long and very tedious by almost all the subjects. They took, on average ten minutes to read it. As these subjects can be considered as above average readers, it can be expected that secondary school children would take longer to read a similar text.

(b) if possible some examples should be provided when the interviewer explains the construction of the semantic net so as to avoid interruption of the discussion about

*what* facts are to be represented in the net as opposed to *how* they are to be represented.

(c) some reference to context appeared to be necessary as subjects did not feel particularly motivated by the topic: the subjects could not see the point of the activity they were doing and some people changed their attitudes towards the activity when they read that food irradiation was allowed in Brazil.

(d) in general there was a tendency to discuss the *issue* of food safety in terms of personal beliefs or preferences rather than in terms of the argumentation of the text which was grounded on scientific facts about the atomic structure of matter. In the main study this led to constraints on the choice of the text to be used and the kinds of questions asked.

## **6.4 FINAL REMARKS**

### **6.4.1 A GENERAL VIEW OF THE RESULTS**

Looking at the results as a whole one can see how background information on students' sources of knowledge can aid the understanding of their conceptualisation of the subject.

Returning to Chapter 4 where the ways in which the concept of radioactivity is presented in both formal and informal sources of information were discussed, one can see that the topic is very much associated with hazards and destruction as well having a remote and intangible character. In students' accounts this remoteness was well illustrated by the lack of specific vocabulary to refer to radioactivity. The associations they made were mainly with intangible entities.

## 6.4.2 METHODOLOGICAL POINTS

The results obtained also enabled the researcher to implement some changes in the questionnaire to be used in the main study. These will be presented below under the main headings adopted earlier.

### **Knowledge and Society**

For questions related to Sources of Knowledge there were two major lines of change. Firstly some questions were omitted. This decision was justified by the fact that the questionnaire was already too long. Therefore some questions were omitted and others re-phrased so as to avoid repetition and distraction. One example of a question which was removed from the questionnaire is the one that asks for a summary of what happened in Goiânia. The fact that the written accounts do not offer the possibility of being either probed or followed-up in a systematic way determined the change. It was also thought that, apart from creating a context for discussion, ideas can be tried and developed more easily in a group discussion when the aim is a collective reconstruction of the event. Another example is the question about being able or not to evaluate risks and why. This question was excluded because, as it has been said earlier, it gave little information, needing, perhaps, a different phrasing. The question may also be regarded as too remote to be properly discussed with these particular students, due mainly to the physical distance between the subjects and the locality where the event took place. Risks are discussed instead in the interview study.

### **Nature of Knowledge**

With regard to questions concerning Nature of Knowledge it was decided to keep the same format for the questions to be applied in the main study as both were easily comprehended and did not seem to present difficulties. It was decided to include other entities in the list proposed in question 1 ("Do you think that radioactivity can, in some way, be seen as...?" so as to have a clearer picture of the nature of the associations made as well as to check the tentative interpretations proposed. With respect to Question 2 it was decided to present the properties or proposed attributes as adjectives instead of phrases and avoid cases where one extreme of the scale was the negation of the other like, for example "does not act by contact vs acts by contact" which are mutually exclusive making the mid point in the scale liable to misinterpretation. In the version tried in the main study extremes of

the scale are opposite-in-meaning but complementary adjectives. The number of scales was also increased so that clearer dimensions along which radioactivity is conceived could emerge.

It is possible to speculate that a possible undifferentiation between the concepts of radioactivity, radiation and radioactive material, as reported elsewhere in this thesis, might have been responsible for a rather blurred picture of students' conceptualisation of radioactivity in this study. For this reason it was decided to have three different presentations of the questionnaire to be used in the main study, which would then ask the same questions about the three different concepts so that criteria for differentiating the concepts could emerge.

### **Learning and Thinking**

The interviews were modified so as to allow a more focused discussion of the topic as opposed to the issue. This was done by starting the group discussion with questions related to pieces of news published at the time of the accident which, however, did not bring up issues of social responsibilities or personal concerns directly. These were pieces of factual information, as opposed to an explanatory text presented later, written so as to explain some properties of Caesium 137 to lay people.

The reference to the accident of Goiânia is present at the beginning when students are asked to recall the event. The next step, which is triggered by commenting upon two pieces of news (one concerning the contamination of a distant body and the other the project of a deposit to store waste generated by the accident) involves a discussion about the nature of radioactivity, how radioactive contamination occurs, how it propagates and how radiation affects the human body. This is done so as to allow students to explain in more detail what they meant by some of their choices in the questionnaire. After that the explanatory text is presented, discussed by the group and summarised through the semantic net. The interview is structured in such a way that, little by little, the initial emphasis on the social context is gradually substituted by a more focused approach on the problems related to understanding specific information about radioactivity.

---

---

## CHAPTER VII

### STUDENTS ANSWERING ABOUT RADIOACTIVITY

---

---

#### 7.1 PREAMBLE

The analysis of data from the main study will be divided into three main headings related to the nature of results presented. These three main headings are, as before: (i) Knowledge and Society; (ii) Knowledge and Individual and; (iii) Learning and Thinking.

#### 7.2 THE SAMPLE

Schools used in the main study were the same or very similar to those used in the pilot study. Therefore most of the comments made in section 6.2.1 apply here. Questionnaires were applied in 3 public schools and two private schools in Rio de Janeiro. There were approximately 35 students in each classroom though some night shift classes could have as many as 50 students. Students took, on average, 40 minutes to answer the questionnaire. Altogether 333 questionnaires were applied; 80 in the night shift from the public school, 125 in the morning shift of the public schools and 129 in the private school.

The age range and mean age for each group were as follows.

School	Mean Age (YO)	Age Range (YO)
Private School	17	16 to 18
Public Morning	18	16 to 22
Public Night	26	17 to 31

Table 7.1: Mean age and age range for students as reported by themselves.

All students were from the third year and by that stage had already covered units on Kinematics, Dynamics, Heat and Temperature and Waves. Syllabi for the third year cover Optics and Electricity and Magnetism.

The questionnaire (shown in appendix 7.1) contained seven questions and had basically the same format as the pilot questionnaire. The first two questions tackled the issues on the Nature of Knowledge and the five remaining ones concerned Knowledge and Society. As explained earlier (section 6.4.2) some questions were left out and some were modified in the light of the analysis of the pilot study results. As far as questions concerned with the Nature of Knowledge are concerned, these modifications relate mainly to the inclusion of more features in both Question 1 and Question 2 so as to be able to resolve some ambiguities in the interpretation of the data. Another important change is that the questionnaire was presented in three different versions, which, however, contained the same questions, aimed at investigating the concepts of radiation, radioactivity and radioactive material. The main reason for this was to investigate the undifferentiation of the concepts as reported in current research (Eijkelhof & Millar, 1988). Equal numbers of questionnaires with different presentations were distributed in each classroom so as to guarantee that, although it was not the same student who answered the three different presentations of the questionnaire, samples were equivalent. The new questionnaire dealt with the following questions.

---

What are students' evaluations of their own knowledge on the subject?

What are students' sources of information?

What are the levels of interest students report to have?

What is their self-evaluation of their interactions with radioactivity related information?

What are students' conceptualisations of the concepts of radioactivity, radiation and of radioactive material?

---

### **7.3 KNOWLEDGE AND SOCIETY**

Some results related to Knowledge and Society have been already presented in the previous chapter where the pilot work results have been discussed. As the schools used in the main study were either similar to or even the same ones used in the pilot study many of the results can be seen as be directly related or seen as an elaboration from the ones presented earlier.

When asked to evaluate the knowledge they possessed about radioactivity, students tended, regardless of their background, to say that this was “very little” or “superficial”. Chart 7.1 shows total and breakdown for different school groups which show a striking similarity in the pattern of choices, but with some tendency for night shift public school students to claim better knowledge.

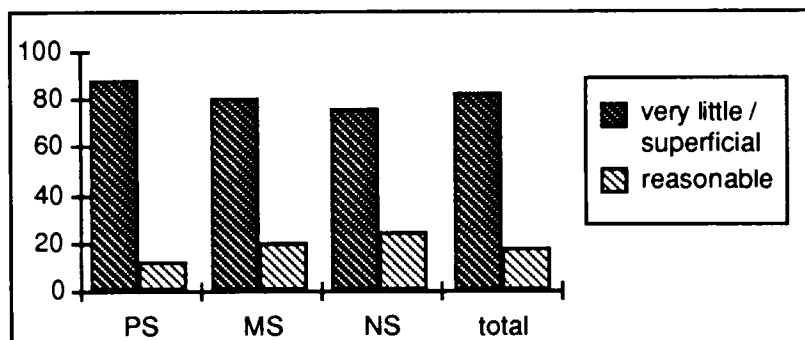

Chart 7.1: Totals and breakdown for answers to question: “Would you say that the knowledge you have about radioactivity is...” (percentages are calculated over total number of choices made)

This shows clearly that the majority of students do not feel they are well informed about the subject, though they do admit having had contact with a variety of related information in a subsequent question.

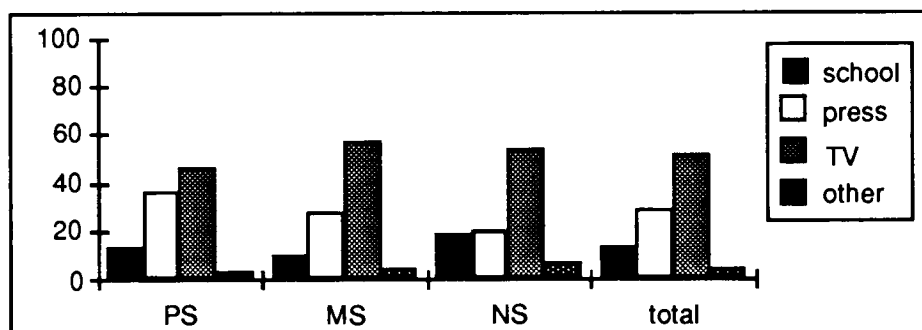

Chart 7.2: Total and breakdown for question “Where did you get your knowledge of radioactivity from?” (percentages are calculated over total number of choices made)

Chart 7.2 shows how choices between different sources of information vary for different groups. However, a student could select more than one choice. One gets an idea of the variety of sources by calculating the ratio of the total number of choices to the number of students. These were respectively PS=1.33, MS=1.36 and NS=1.29 which are very similar to one another and indicate that most choose more than one alternative.

For all groups, television appears to be the most frequent and accessible source of information. Although in this case, because students were able to choose more than



one option, it is not possible to make any statistical significance tests, one can still look at the trends. These suggest that the private school group possibly rely more on the press than the others. Comparing these results with the ones of the pilot study when similar questions were asked it is possible to interpret Chart 7.2 as a combination of Charts 6.8 and 6.9, shown in chapter 6, television would have been a major source of information after the radiological accident of Goiânia.

Bearing in mind that schools in this sample are essentially the same as the ones used in the pilot work, if one returns to last chapter where results of the pilot work are discussed, it is possible to try and make a few comparisons. That discussion identified sources of information before and after the accident showing that although most of the knowledge students had before the accident was acquired through school related sources, it was through television that the majority in all groups first heard about the event. By comparing charts 6.10 and 6.11 in chapter 6 it is possible to see that a greater number of students report having obtained information about radioactivity from TV, as compared to the number of students who, at first, have looked for it in TV. (see pages 113, 114 and 115) .

As the question is not asked in a retrospective mode, chart 7.2 could then be interpreted as if the result of the influence of the coverage of the accident by the media, especially by TV.

Other sources mentioned depict the distinct possibilities students had of interacting with radioactivity related information, with private school students evoking talks with experts and visits to nuclear power stations while morning shift public school students mention radio and school assignments and night shift school students not mentioning any alternative source other than talks with classmates.

Chart 7.3 shows the extent to which students expressed interest in knowing more about radioactivity, which is, in general, broadly similar with possibly some differences between the groups.

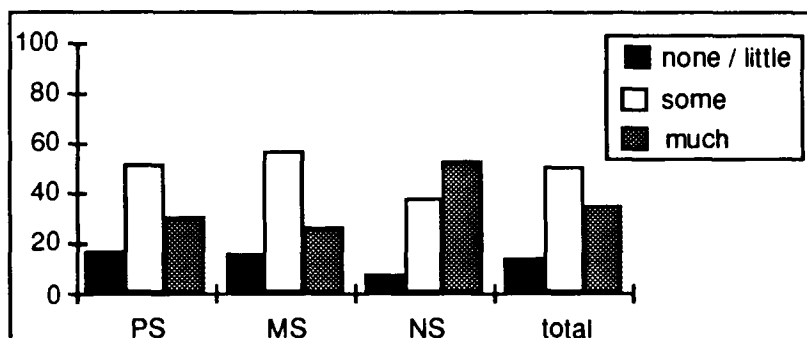

Chart 7.3: Total and breakdown for question: "Your interest in knowing more about radioactivity is..." (percentages calculated over total number of choices made)

Despite the fact that all of them express interest in the subject to some extent, the night shift group more often report a greater degree of interest. It may be the case that night shift public school students, as possessing a higher level of commitment to social responsibilities, could have a stronger motivation to be interested in the subject.

However, when asked to say what are related topics they would want to know more about students from the three different school groups provided a remarkably similar pattern of choices. Chart 7.4 shows the percentage of choices associated with each of the options shown in Table 7.2 as well as with a blank option should students wanted to mention another example of radioactivity related information:

- (a) scientific explanations about the nature of radioactivity;
- (b) how radiation affects both living and non-living matter;
- (c) applications of radioactivity in Medicine;
- (d) applications of radioactivity in power production;
- (e) applications of radioactivity in problems related to nuclear waste;
- (f) information about accidents involving radioactive materials;
- (g) security and control measures necessary when dealing with radioactive materials
- (h) applications of radioactivity in food presevation and sterylisation;
- (i) applications of radioactivity in industry and;

Table 7.2: Types of information presented in questions about interests and evaluation of understandings.

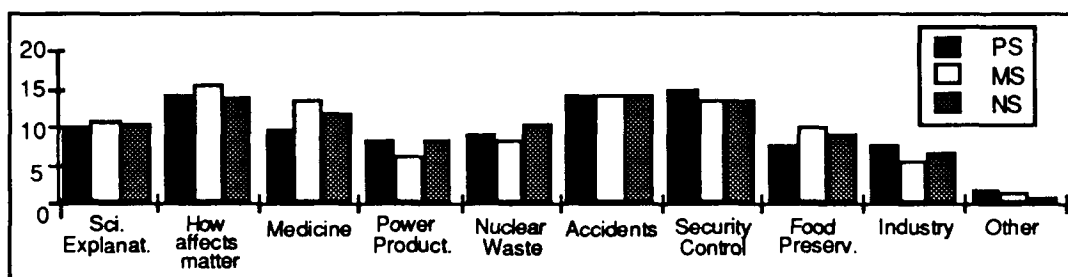

Chart 7.4: Breakdown for question: "Which of the topics below would you be more interested in knowing about?" (percentages calculated over total number of choices made).

Students say they are more interested in knowing about “security and control measures”, “accidents involving radioactive material” and “how radiation affects matter”. “Applications of radioactivity in Medicine” and “scientific explanations about the nature of radioactivity” are also mentioned, though less often. Moreover, issues on “power production”, “applications in Industry” and “applications involving problems related to nuclear waste” were mentioned only by a minority. Thus it can be said that the choices for topics of interest are wide in scope and diversified.

In this case, the relative number of choices is nearly the same for all groups (PS=4.53; MS=4.29; NS=4.96). That is, each student makes several choices selecting almost half of the possibilities. With respect to alternative answers, although the their percentage was almost negligible for any of the groups they are not different in kind. They are all related, in one way or another, to effects of radiation in the environment and its consequences for the future of mankind as well as expressing some concern towards its military uses.

Students were also asked to evaluate different types of information in relation to both the familiarity they might have with it and their understanding of it. The actual question required students to indicate, for all types of information listed in table 7.2, whether they would say that they: already knew it; looked for it; actually found it; thought it proved to be helpful; thought it would have been helpful; still do not understand it.

Most of the information they already knew appears, for the three groups, to be mostly related to accidents involving radioactive material and less to applications of radioactivity in problems involving nuclear waste. All alternatives tend to be equally chosen except for "accidents involving radioactive material". Interestingly around twenty per cent of the choices of both morning shift and night shift public school students were of "scientific explanations about the nature of radioactivity". However, one aspect that stresses this difference more strongly is that the relative number of choices is not the same for all groups with the private school group making almost twice as many choices as both the morning and night shift public school groups. The figures are as follows: PS=1.75, MS=1.30 and NS=0.98.

STUDENTS ANSWERING ABOUT RADIOACTIVITY

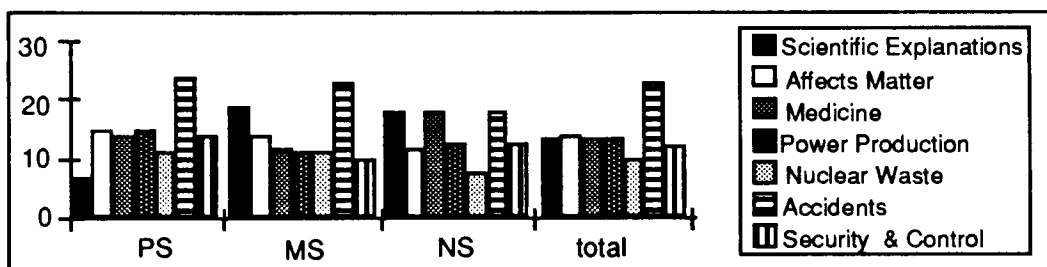

Chart 7.5 : Things you already knew about before the accident of Goiânia (percentages calculated over total number of choices made)

If one compares the answers given by different groups in relation to types of information which were sought and types of information which were actually found it is possible to see that, in general, students say they were able to find what they were looking for. Again the relative number of choices is different for the three groups though similar to one another. In the case of the question about types of information looked for these numbers are: PS=1.57, MS=1.26, NS=0.81 and; PS=1.78, MS=1.21, NS=0.65 for the question about types of information which was actually found. These indicate that there must have been some omissions in the night shift group while in the private school group some students chose more than one option. However, for the three groups, it was information in context, that is, information about issues directly connected with the event and its consequences, such as "information about how radiation affects both living and non-living matter" and "information about security and control measures necessary when dealing with radioactive material", that was mostly sought. Information on applications of radioactivity in Medicine, power production and problems involving nuclear waste were not especially sought after.

In all the three groups less people could find information in the form of "scientific explanations of radioactivity" than the ones who actually looked for it.

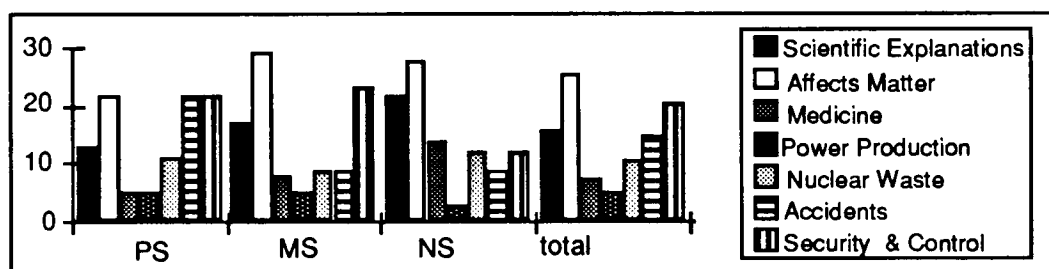

Chart 7.6: Breakdown for types of information you looked for after the accident of Goiânia (percentages calculated over total number of choices made)

The answers to the question of types of information which were actually found can also be interpreted as reflecting the way in which the nature of available

information was perceived by students and is consistent with how the event was covered by the media<sup>1</sup>. This information mainly concerned issues directly connected with the accident such as "security and control measures necessary to dealing with radioactive material", "information about accidents involving radioactive material" and "applications of radioactivity in problems involving nuclear waste". It can be seen that some of the students from the private school group tend to make more than one choice, as indicated by their relative number of choices ( PS= 1.78, MS= 1.21 and NS= 0.6). Despite that, the patterns of choices for the three groups are not very different with, perhaps, the night shift group being more often interested in "security and control measures".

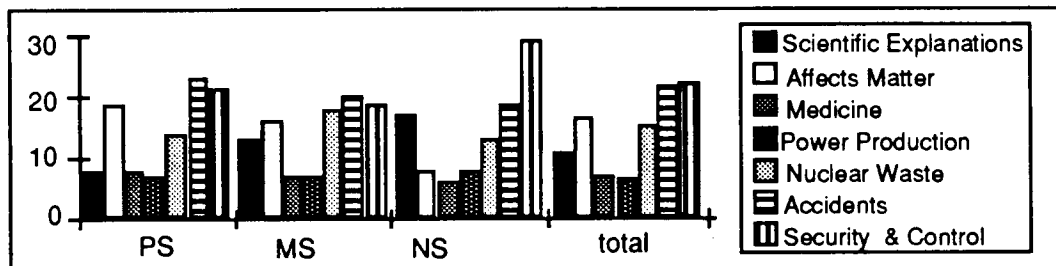

Chart 7.7 : Breakdown for types of information you actually found after the accident of Goiânia (percentages calculated over total number of choices made)

The responses given by different groups to the question about information that was actually helpful were rather similar. Again, applications of radioactivity in Medicine, power production and in problems involving nuclear waste corresponded to a minority of choices. Most of the preference in the three groups related to information about accidents, security measures, scientific explanations about the nature of radioactivity and ways in which radiation affects matter. In this case the relative number of choices is as follows: PS= 1.33, MS= 0.96 and NS= 0.86. This reveals that there were omissions by the night shift public school group by contrast with the private school group in which some students chose more than one option. With exception of the option concerning "security and control measures" which was more often chosen by the night shift group, none of the other options was distinctively preferred by a given group.

In relation to information that proved to be helpful, choices of different groups were quite similar to one another. The options related to "accidents involving radioactive material" and to "how radiation affects matter" were very often chosen by all

<sup>1</sup>In fact this evaluation is in consonance with a survey of articles published both in the main newspapers and magazines as reported in chapter 4 as well as a brief analysis of the contents of some television reports at the time of the accident.

groups. Information on “security and control measures” was also frequently mentioned, especially by the private school group. This pattern of choices suggests a picture which describes students’ primary concerns as determined by the actual circumstances of the event, that is, what was seen as problematic was the very nature of what had happened and its possible consequences.

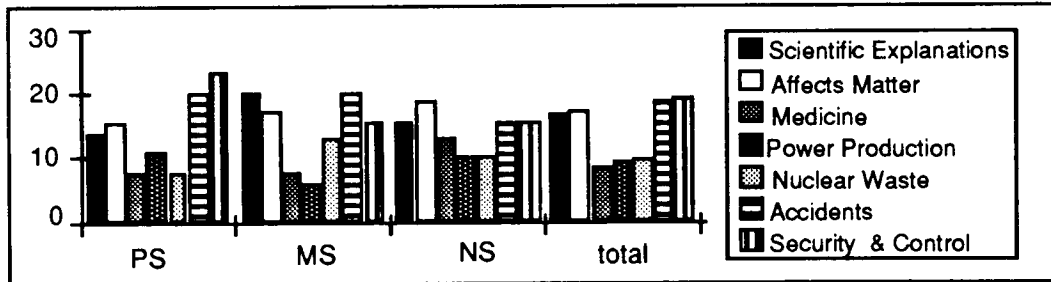

Chart 7.8 : Breakdown for types of information which proved to be helpful to understand comments about radioactivity at the time of the accident of Goiânia (percentages calculated over total number of choices made)

This pattern of choices is different to the one given to the question about information which would have been helpful. In this case about a third of the subjects in each group say they think that "scientific explanations about the nature of radioactivity" would have been helpful so as to understand comments made about radioactivity at that time. Similarly to the previous question, information not directly connected to the accident itself accounted only for a minority of choices. Again the night shift group presents the lowest relative number of choices, PS= 1.55, MS= 1.4 and NS= 0.99.

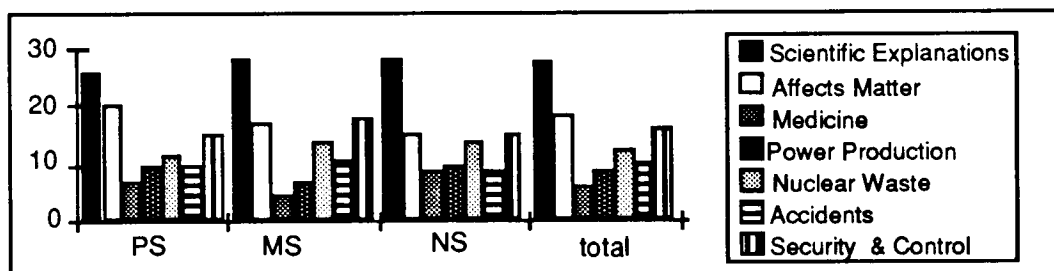

Chart 7.9: Breakdown for types of information which would have been helpful to understand comments about radioactivity at the time of the accident of Goiânia (percentages calculated over total number of choices made)

Finally, all groups report a wide range of outstanding doubts, with rather equal numbers of choices over type of information, in the questions “What are the things you still do not understand?”. Although the percentage of choices is not particularly high for any of the types of information it is not diversified either. An interesting point is that, for all groups, the option on information about “accidents involving

radioactive material” is less often chosen. Information in Chart 7.10 can be compared directly as relative number of choices are very similar, with students making at least two choices as indicated by the following numbers: PS=2.12, MS=2.15 and NS=2.23.

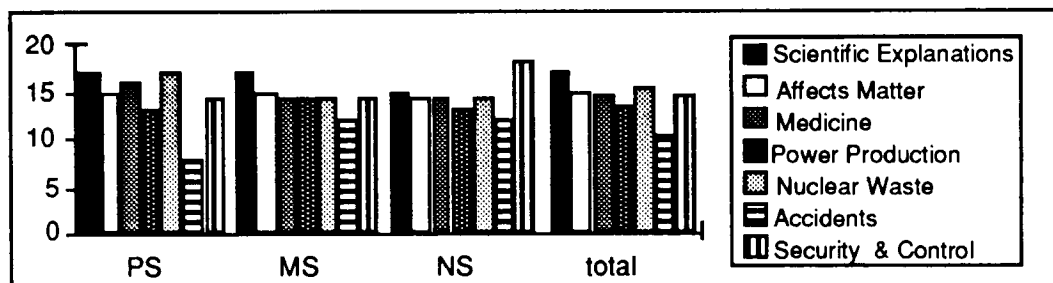

Chart 7.10 : Total and breakdown for question "Are there things you still do not understand?"

### 7.3.1 SUMMARY OF RESULTS CONCERNING KNOWLEDGE AND SOCIETY

Although there may be some differences between the groups, the most striking aspect is their similarity, despite the substantial variety in their social educational background.

As far as both their evaluation of both their own knowledge and their specific topics of interest are concerned, there is little difference between the choices of the groups. All of them admit not knowing very much about it and, though to a different degree, the majority report possessing some interest in knowing more about it. The choices for topics in which students were more interested is remarkably similar for all the groups and reveals a wide spectrum of interest. It would be possible to interpret this result as indicating either a general lack of interest or a general lack of grounds to decide which counts as relevant information. The first possibility is less plausible because of the interest students claimed to have. The second one seems to be more plausible especially when compared to the answers given to the question of outstanding doubts, which were wide in variety.

The questions requiring a retrospective evaluation of their own interaction with radioactivity related information appear to have stressed night shift public school students' problems with understanding the subject more strongly than for the others. In fact, for some questions there is a minority of blank answers which is

always higher than the corresponding figure for the other groups. This may be understood if we consider that private school students have, in principle, greater possibilities of finding out information than public school students.

## **7.4 NATURE OF KNOWLEDGE**

### **7.4.1 ASSOCIATIONS AND MENTAL IMAGES: HOW IS IT LIKE?**

#### **7.4.1.1 An Overall Picture**

An analysis of the overall totals of yes answers given to each entity when asked “Is - radioactivity/radiation/radioactive material -, in some way, like...?”, regardless of differences due to both school group and presentation of the questionnaire, reveals no a clear-cut preference for a given entity or group of entities. The overall picture is that the concepts of radiation, radioactivity and radioactive material, or respectively, RN, RY and RM, as they will be referred to hereafter, *can be seen in many ways, as like many different things*.

This is best understood if we remember that, according to their own accounts, students, in general, do not know very much about radioactivity. Apart from that, their interaction with related information can also be thought of as having been fragmented, incidental and non systematic. Therefore, it is very unlikely that they are able to establish grounds for deciding about similarities and differences between the concepts and the proposed entities, which was reflected by the diversity in the responses given.

Table 7.4 presents overall totals. Figures shown are actual counts and are presented in descending order. In this question, students were asked to tick or cross each alternative.



## STUDENTS ANSWERING ABOUT RADIOACTIVITY

Entities	Count	%
ENERGY	276	83
X-RAYS	242	73
M' FIELD	228	68
RAYs	201	60
GAS	191	57
LIGHT	181	54
HEAT	173	52
ELECTRICITY	162	49
DUST	157	47
AIR	150	45
CLOUD	143	43
WAVES	142	43
SMOKE	133	40
OBJECT	82	25
MOVEMENT	80	24
WATER	54	16
SOUND	54	16

Table 7.3: Overall totals for "Is Radiation/Radioactivity/Radioactive Material like...?" N=333

An inspection of the table shows that at one extreme there are entities such as "energy", "x-rays", "magnetic field", "rays", "gas", "light" and "heat" representing the most preferred options, and, at the other, with low scores, "object", "movement", "water" and "sound". Although these numbers are not unambiguous enough to permit a clear-cut splitting of the entities, they might suggest an indication that the concepts of RN, RY and RM seem to be least associated with entities which are accessible to the senses or which are material, and most associated with some kind of energetic intangible entity.

In order to be able to provide a more accurate classification of entities a cluster analysis was conducted. The results of the cluster analysis were used as an exploratory tool which also suggested a possible classification of students' responses. The dendrogram below depicts the results obtained using the complete linkage method.

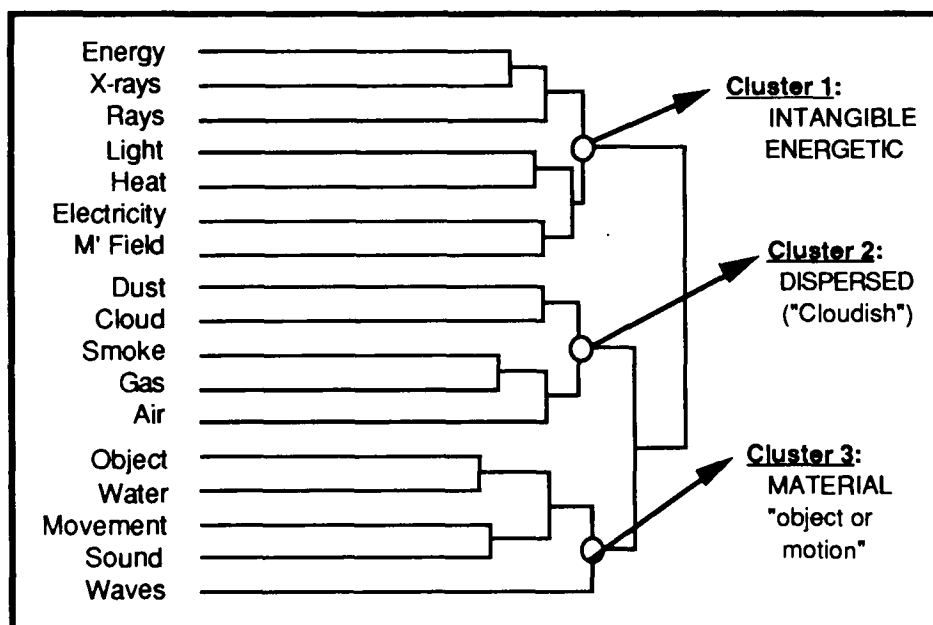

Figure 7.1: Cluster Analysis (complete linkage) for all schools and all presentations

The cluster analysis, together with the results in Table 7.4, suggests that radiation, radioactivity and radioactive material are most seen as like the first cluster, least like the last and somewhat like the second.

The three main clusters in figure 7.1 can be described as follows. The first group contains energetic intangible entities such as “energy”, “x-rays”, “rays”, “light”, “heat”, “electricity” and “magnetic field”. The second gathers material dispersed entities such as “dust”, “cloud”, “smoke”, “gas” and “air”. The third puts together entities which are directly accessible to the senses such as “object”, “water”, “movement”, “sound”, and, less interpretable in this way, “waves”. Again, it is important to emphasise that these entities are grouped together in relation to their degree of resemblance to the proposed concepts and not in relation to the degree they resemble one another. Thus it seems that the distinctions made relate mainly to activity, materiality/dispersal, and accessibility to the senses. Furthermore, taking the second and the third group together and comparing them with the first group there seems to be a split between entities which are familiar in everyday life in the second and third groups and entities which are less familiar in the first group.

This interpretation is corroborated by the results of a factor analysis conducted with the same set of data. The Orthotran/Varimax solution gives 5 factors, which are all orthogonal. The Bartlett test of sphericity gives  $p \sim 0.0001$ , with  $\chi^2=628.415$ , for 152 degrees of freedom. The factor loadings for the orthogonal transformation solution, are presented in table 7.4.

ENTITIES	Factor 1	Factor 2	Factor 3	Factor 4	Factor 5
Air	-.182	.233	-.033	.062	.771
Waves	.015	-.075	.614	.029	-.082
Cloud	.071	.663	.040	.042	.029
Rays	.429	-.022	.298	.077	-.250
Dust	-.372	.643	.114	-.031	-.228
Water	.062	.144	.173	.765	.088
X-rays	.248	-.069	.343	-.187	-.074
M' Field	.610	-.001	-.101	-.007	-.141
Electricity	.723	-.660	-.031	-.005	-.004
Heat	.246	.432	.403	-.291	.017
Object	-.006	.241	-.115	.602	-.480
Light	.499	.147	.185	-.199	.103
Energy	.376	.112	.160	-.479	-.187
Sound	.412	-.071	.289	.231	.350
Movement	-.049	.075	.663	.082	.196
Gas	.036	.569	-.448	.079	.307
Smoke	-.003	.668	-.168	.247	.248

Table 7.4: Factor loadings from factor analysis of all Question 1 data

The first factor, which has high loadings on “electricity”, “light”, “rays” and “sound” was interpreted as relating to an **Immaterial Active** character. The second factor, characterised by high loadings on “smoke”, “cloud”, “dust”, “gas” and “heat”, relates to a **Particulate Non-Active Dispersed** nature. Thirdly, a **Non-Visible Active Non-Located** character is revealed by factor 3 as its highest loadings are “movement”, “waves”, “heat”, and, negatively, “gas”. Factor 4 brings together “water”, “object” and, negatively, “energy”, which may delineate a **Non-Active Substance-like** character. Finally, to help the interpretation of factor 5 as **Non-Located Non-Active**, there are “air” and, negatively, “object”, though the loading of “sound” here is less helpful to such an interpretation.

Interpreted in this way, factors 3 and 4 also help to resolve the difficulty in interpreting cluster 3 by splitting invisible dispersed active entities from non active substance-like ones.

It appears to be the case that the factors are in consonance with the proposed classification derived from the cluster analysis which emphasises that *activity*, *particulate dispersed nature* and (lack of) *accessibility to the senses* are relevant dimensions along which students conceive the concepts. In other words, these aspects can be thought of as summarising students’ general perception of the concepts of radiation, radioactivity and radioactive material.

Combining the two analyses leads us to suggest that radiation/radioactivity and radioactive material are seen like factor 1, moderately as like factors 2 and 3 and not

as like factors 4 and 5. In other words, it is most likely to resemble something immaterial and active, perhaps dispersed.

#### 7.4.1.2 Differences Between Schools Types

Chart 7.11 shows the breakdown of yes answers given to Question 1 in relation to the three different school groups. Figures shown are percentages of the total number of choices in each group. The ratio between the total of 'yes answers' and number of subjects in each group is similar for the three groups and are as follows: PS= 8.3, MS= 7.9 and NS= 7.4. Apart from being similar enough to allow a direct comparison between the three school groups, these numbers also show that, on average, students ticked about half of the possible alternatives available. In fact, virtually none chose less than three entities.

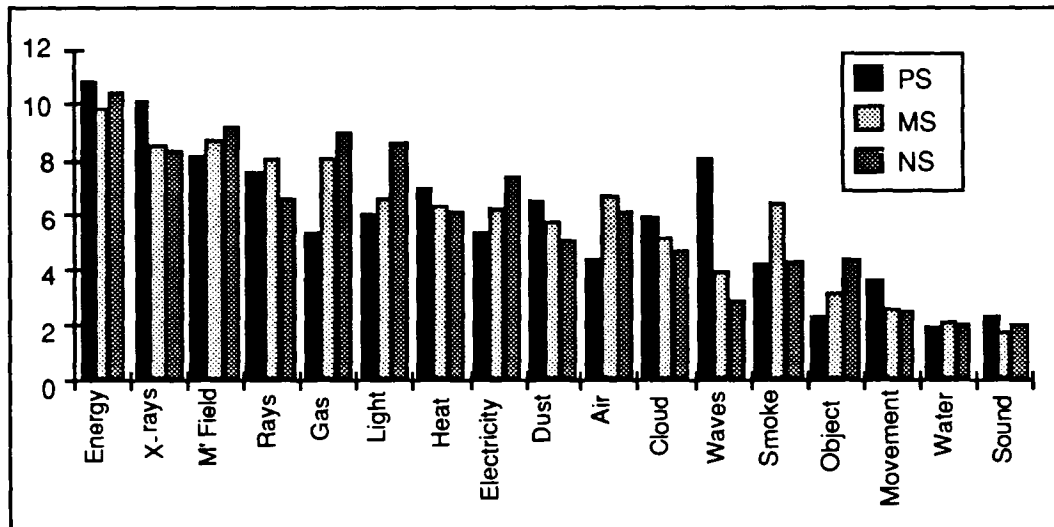

Chart 7.11: Breakdown for different school groups in Question 1 (figures are percentages of the total number of choices for each school group)

The entities are shown in the picture in descending order of the total number of choices and not in the actual order they were presented in the questionnaire. An inspection of chart 7.10 shows overall the great similarity between school groups. Exceptions are *waves* - notably chosen by the private school group, *gas* - also notably less often chosen by the private school group, and possibly, *smoke* - more often chosen by the morning shift public school group.

To see if clusters depended on school type, the cluster analysis was repeated for school groups independently. The cluster analyses give three main clusters which are the same for all groups. One group brings together "*energy*", "*x-rays*",

"magnetic field", "electricity", "rays", "light", and "heat". Other group is identified by "movement", "sound", "waves" and "object", whilst "smoke", "air", "gas", "dust" and "cloud" come together in another group. The fact that these three clusters can be identified in the dendrograms representing the analyses done for three school groups, indicate that students from the three different school groups tend to separate the proposed entities in a rather similar way. Altogether it is possible to observe a striking similarity between them though there may be a hint that 'intangible energetic' form a stronger cluster for the private school group where they appear to be more associated. These clusters are shown in figures 7.2, 7.3 and 7.4.

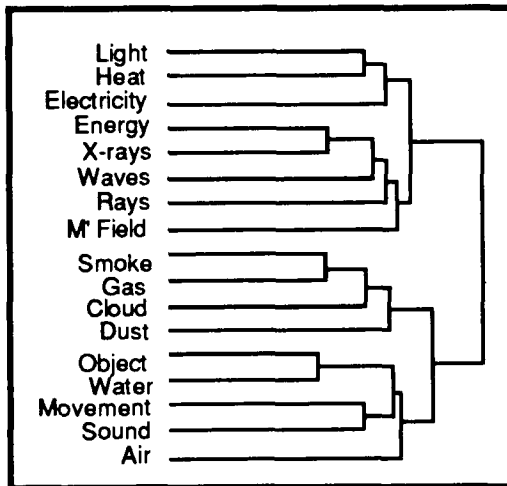

Fig.7.2: Cluster analysis (complete linkage) for Private School group (N=129)

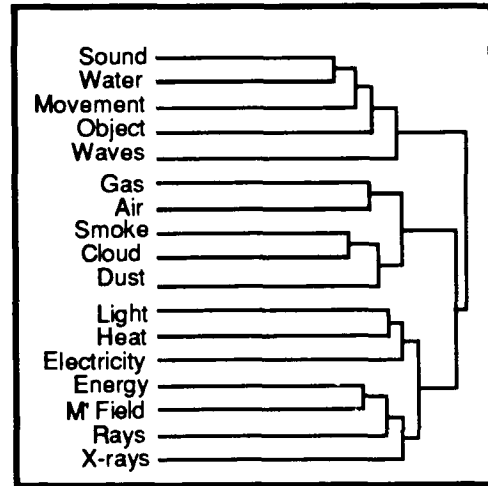

Fig.7.3: Cluster analysis (complete linkage) for Morning Shift School group (N=124)

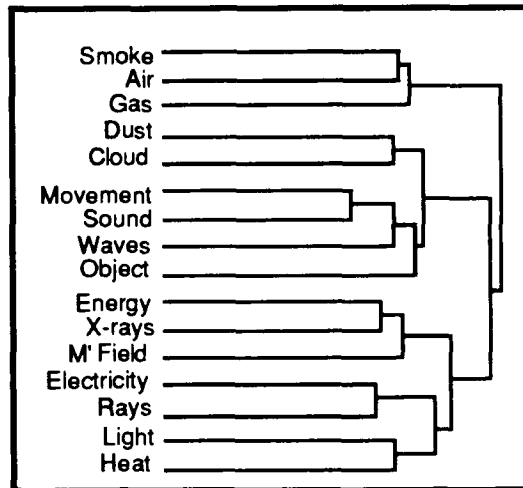

Fig.7.4: Cluster analysis (complete linkage) for Night Shift School group (N=80)

Differences between students' responses were examined by performing an analysis of variance on all students' responses to each entity. Significant differences, with  $p < 0.05$  (with some of them being actually less than 0.001), between responses due

to differences in school group were found only in the cases of the following entities: "air", "waves", "x-rays", "energy", "gas" and "smoke". For "waves", "x-rays", "energy" and "smoke", the number of 'yes answers' given by the night shift group is smaller than those by the morning shift group, which are even smaller than those made by the private school group. By contrast, "air" and "gas" tend to be more often ticked by the night shift group. It may be that the night shift group is more likely to evoke particulate dispersed familiar entities more often than the others.

To check if the factors remained the same for all three groups, the data were factor analysed separately for each school group. Broadly similar factors tended to emerge and minor differences do not seem to add to the interpretation.

#### 7.4.1.3 Differences Due To Presentation

Chart 7.12 below illustrates the differences in yes answers to Question 1 in terms of the three different presentations of the questionnaire used. There was an approximately equal number of questionnaires per presentation with 110 questionnaires for radiation, 118 for radioactivity and 105 for radioactive material. The ratio between the number of 'yes answers' and the number of students for each group who filled in a different questionnaire were RN=8.2, RY=7.8 and RM=7.8, which shows that about half of the available options were ticked in all presentations.

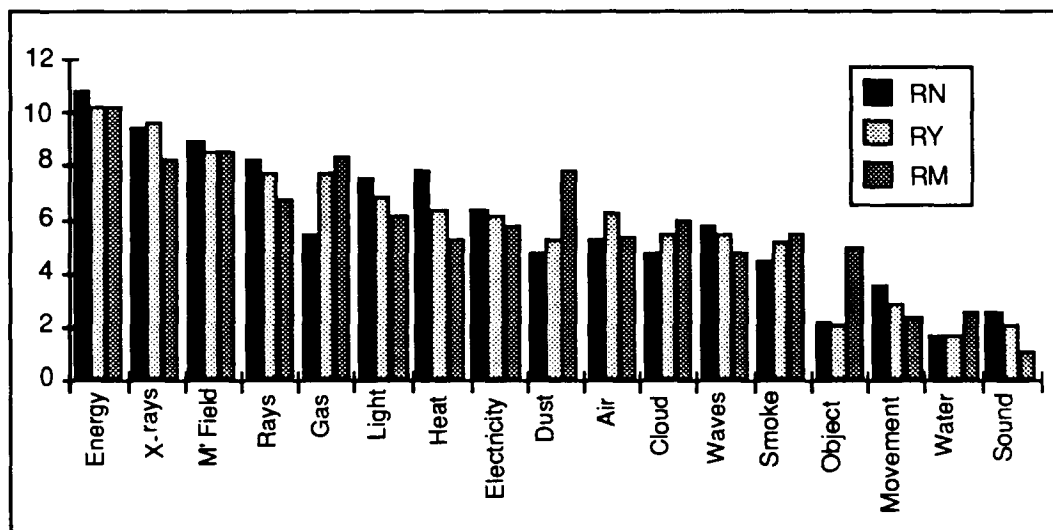

Chart 7.12: Breakdown for different presentations of the questionnaire in Question 1 (figures are percentages of the total number of choices for each presentation)

In chart 7.12 entities are shown in descending order of the total number of choices. The results suggest a quite similar pattern of choices for radiation and radioactivity. They also reflect a preference for associating material entities to the concept of radioactive material more often than to the other two presentations as *dust*, *cloud*, *smoke*, *object* and *water* are slightly more often associated with radioactive material. Otherwise, there are few differences.

Cluster analyses performed on the three sets of data, using the complete linkage method, grouped the data in a quite similar way in all three cases. In fact, groupings were more or less similar to those obtained before for the cluster analyses performed on the data as a whole, with the three main clusters appearing to relate to 'energy/intangibility', 'dispersal' and 'materiality'. Figures 7.5, 7.6 and 7.7 show the clusters for data from each presentation.

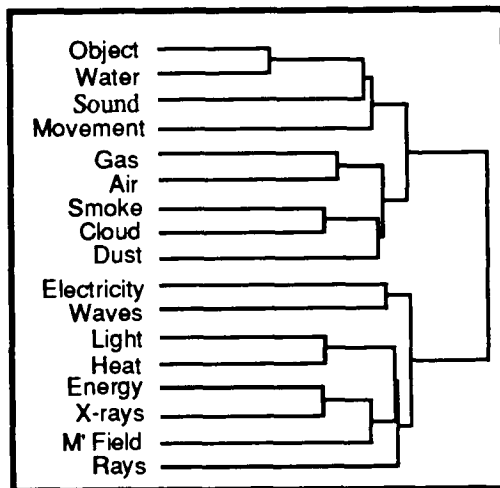

Fig.7.5: Cluster analysis (complete linkage) for Radiation presentation (N=110)

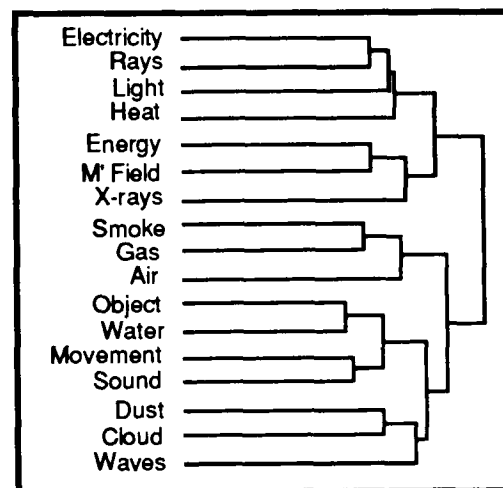

Fig.7.6: Cluster analysis (complete linkage) for Radioactivity presentation (N=118)

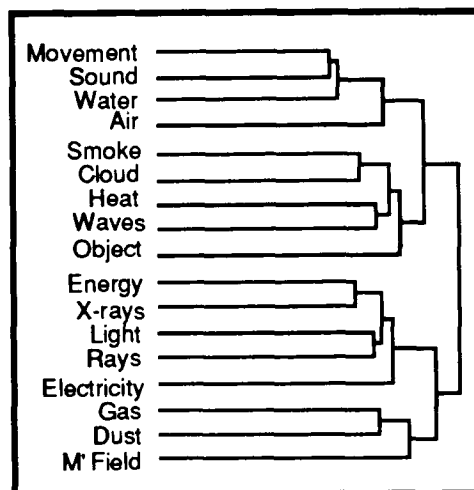

Fig.7.7: Cluster analysis (complete linkage) for Radioactive Material presentation (N=105)

Differences between groups were found to be significant for  $p < 0.05$  (all actually less than 0.01) after an analysis of variance, in the cases of the following entities: “*dust*”, “*heat*”, “*object*” and “*gas*”. These differences relate to the fact that the entities “*dust*”, “*object*” and “*gas*” are more frequently associated with radioactive material whereas the majority of ‘yes answers’ for “*heat*” are in the radiation presentation, followed by the radioactivity presentation.

Again data from the three different presentation groups were factor analysed separately and, similarly as when the three different school groups were factor analysed separately, the general picture of results remained the same, with a few minor differences which do not contribute to any re-interpretation of the factors.

#### **7.4.1.4 Interactions**

Cluster analyses and factor analyses were repeated separately for all combinations of school group and presentations, but no evidence of important changes in structure were seen.

#### **7.4.1.5 Summary of Results Concerning Associations and Mental Images**

The general picture of the data may be summarised by saying that, in general, radiation, radioactivity and radioactive material appear to be seen as a kind of active intangible dispersed entity. The proposed interpretation suggests that students tend to base their judgements upon criteria such as materiality, activity and accessibility to the senses.

The fact that there are not many significant differences due to differences in the groups’ socio-educational background might be explained by the fact that no specific knowledge, other than that which all students were expected to have as third year grade students, was required in order to answer the question. There may be, however, a slight indication that some kind of a better previous general knowledge might be important in the case of the private school group, as they tend to choose “text book” entities more than the others.



The general lack of discrimination between the three concepts is in accordance with other current research on the subject though there may be a hint that a certain degree of differentiation between radioactive material and the other two is made, in the expected way, associating radioactive material more with dispersed matter.

## 7.4.2 PROPERTIES ATTRIBUTED TO CONCEPTS

### 7.4.2.1 Introduction

Because the most striking feature of the results concerning characteristics attributed to concepts is their similarity regardless of differences due either to school background or to presentation of the questionnaire, it was decided that the overall results should be presented and discussed first. Nevertheless there are interesting differences in selected cases and those will also be shown and discussed.

### 7.4.2.2 An Overall Picture

After the pilot questionnaire, Question 2 was modified so as to list forty-four bipolar scales of opposed pairs of adjectives, shown in table 7.5. These were presented, in the order shown, in all three presentations of the questionnaire.

SCALES					
1	M	material vs immaterial	23	A	dangerous vs safe
2	M	momentary vs eternal	24	A	productive vs destructive
3	K	complex vs simple	25	M	divisible vs indivisible
4	A	strong vs weak	26	M	permanent vs transient
5	M	amorphous vs has shape	27	A	secure vs risky
6	M	brief vs lasting	28	K	uncontrollable vs controllable
7	K	ordinary vs special	29	K	detectable vs undetectable
8	A	passive vs active	30	K	useful vs useless
9	M	solid vs fluid	31	A	increasing vs decreasing
10	M	is always there vs comes and goes	32	M	intangible vs tangible
11	M	natural vs artificial	33	K	difficult vs easy
12	A	energetic vs inert	34	M	dead vs alive
13	M	spread vs located	35	M	invisible vs visible
14	M	frequent vs rare	36	K	familiar vs unfamiliar
15	A	destructive vs creative	37	A	passes through objects vs doesn't ...
16	M	has to be made vs grows by itself	38	K	perceptible vs imperceptible
17	M	light vs heavy	39	A	moves by itself vs is carried about
18	A	stable vs unstable	40	K	known vs unknown
19	A	harmful vs beneficial	41	M	abstract vs concrete
20	A	powerful vs powerless	42	A	makes others r'active vs doesn't ...
21	M	not composed of particles vs composed...	43	A	acts by contact vs acts at a distance
22	A	still vs moving	44	K	can be measured vs cannot...

Table 7.5: Scales for Question 2

As previously discussed (section 5.5.2) these scales can be broadly identified with categories such as *materiality* (M), *activity* (A) and *knowability* (K). Table 7.4 shows these (M, A and K) on the left of each scale. The questions aimed at not only providing information on students' ideas about the concepts but also on whether some of the responses would highlight any differentiation between any of the three concepts. The broad headings along which scales could be grouped would then be used as organisational categories, that is, as the main headings along which students' responses could be interpreted.

The procedure for scoring students' preferences was the same as that described earlier in Section 6.2.3.2.2 of the previous chapter where the pilot work results were discussed. In brief, responses were given a score of 1 to 5 and scales whose means were less than three were reversed so that to the most frequently chosen pole corresponded to the highest score. Likewise, reversed means were plotted against a variable called "concur" which measures the extent to which the group agrees in relation to the responses given.

This plot is shown in figure 7.8, cases in bold corresponding to the most frequently selected pole of the scale. Thus, in the top two quadrants are scales for which one pole was much more often chosen than the other, with concurrence within the group increasing from left to right, whereas in the bottom two quadrants cases where the group is undecided between the two extremes of the scale are represented on the left hand side and cases where the group shows a strong preference for the central point of the scale are represented on the right.

Broadly, it can be seen that, in general, the group does not show a high level of concurrence in their responses. The highest levels of concurrence correspond to the Activity aspect and the lowest to Materiality and to some aspects of Knowability.

An inspection of the plot reveals that students, as a whole, take the most polar view of and generally concur about, attributes which characterise the concepts of radiation, radioactivity and radioactive material as complicated, damaging and dynamic as indicated by the position, high in both axes, of *risky* (as opposed to secure), *dangerous* (as opposed to safe), *complex* (as opposed to simple), *active* (as opposed to passive), *strong* (as opposed to weak), *special* (as opposed to ordinary), *destructive* (as opposed to creative), *harmful* (beneficial), *difficult* (as opposed to easy), *brief* (as opposed to lasting) and *increasing* (as opposed to decreasing).

Also often chosen, though with more disagreement between individuals, the following scales reinforce the previous interpretation. They are: *energetic* (as opposed to inert), *powerful* (as opposed to powerless), *makes other bodies radioactive* (as opposed to doesn't make...), *detectable* (as opposed to undetectable), *composed of particles* (as opposed to not composed...), *passes through objects* (as opposed to doesn't pass...), *moving* (as opposed to still), *unfamiliar* (as opposed to familiar) and *intangible* (as opposed to tangible).

Overall, their preferences indicate that the concepts are seen as *composed of particles* and *intangible*, which denotes a contradiction in students' views. Not surprisingly both correspond to a pattern of choices which relates to some level of disagreement. This apparent inconsistency might be seen as an indication of students' insufficient knowledge and consequent lack of grounds for attributing properties to the concepts. It could also be interpreted as an instance of the undifferentiation of the concepts. A third possibility is that, as data from the three presentations were put together for the sake of an overall analysis, these apparent inconsistencies actually correspond to responses given more often to one concept than the other. This point will be discussed in detail in the next section, where differences between the results of the three questionnaire presentations are presented.

Scales the choices for which do not characterise clear-cut properties of the concepts seem to be those concerning its permanence and its natural existence. Evidence is shown in the bottom right hand corner of the plot that students are mostly and consistently in doubt whether any of the three concepts can be seen as *solid or fluid, light or heavy, permanent or transient, if it is always there or comes and goes, stable or unstable, natural or artificial or momentary or eternal*. In so far as there was any preference for one pole it was towards *fluid, light, transient, is always there, artificial, unstable* and *eternal*. Again these choices may suggest some potential contradictions though, broadly, they seem to be mostly related to the less stable and real.

Features about which students who appear to hold opposing views (bottom left corner of the plot) seem to concern the autonomous character of and the material nature of the concepts. Thus there are opposing opinions as to whether any of the concepts is *spread or located, visible or invisible, perceptible or imperceptible, frequent or rare, material or immaterial, dead or alive*. Or whether they *act by contact or at a distance, move by themselves or have to be carried about, have to*

*be made or grow by themselves, as well as whether they are useful or useless, abstract or concrete, controllable or uncontrollable, momentary or eternal. If there are tendencies to one pole or another, they appear as a slight preference towards: material, invisible, perceptible, rare, alive, acts by contact, moves by itself, has to be made, controllable and useful.*

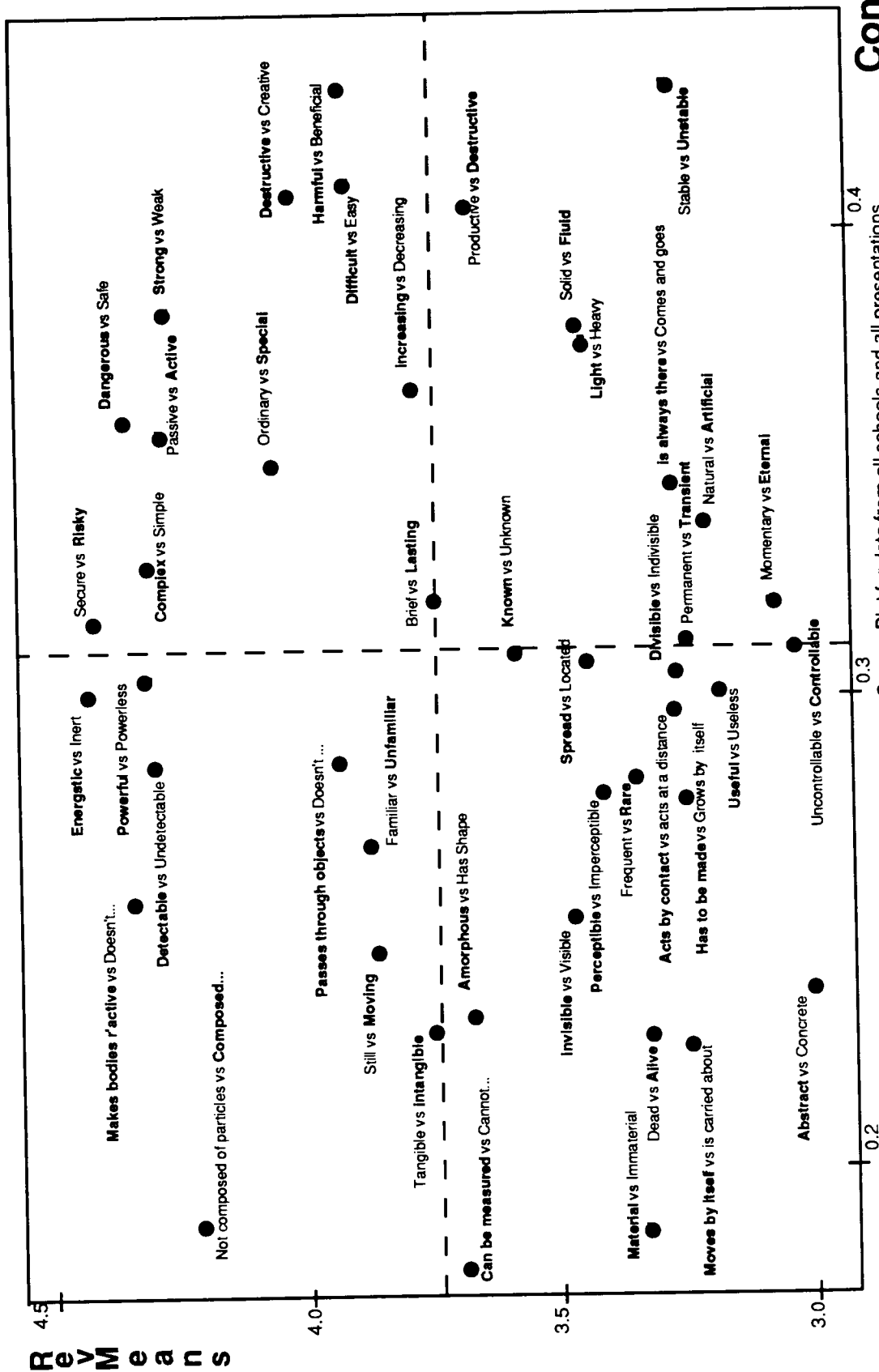

Figure 7.8: Reversed Means vs Concur Plot for data from all schools and all presentations.

Figure 7.9 extracts an interesting general result from the plot. It shows the same as figure 7.8 but with points marked according to the classification, *materiality*, *activity* and *knowability*. Scales relating to materiality and activity appear in distinct regions of the plot. Students appear to be, in general, undecided and not concurring about materiality. Activity, however, seems to yield sharper distinctions between the poles and provide a higher level of concurrence. As far as knowability is concerned, they tend to choose *special*, *complex*, *detectable*, *unfamiliar* and *difficult* which corresponds to a picture of something real but not readily accessible to ordinary people. They cannot decide, however, whether it *can be controlled* or *useful*, *perceptible* or not.

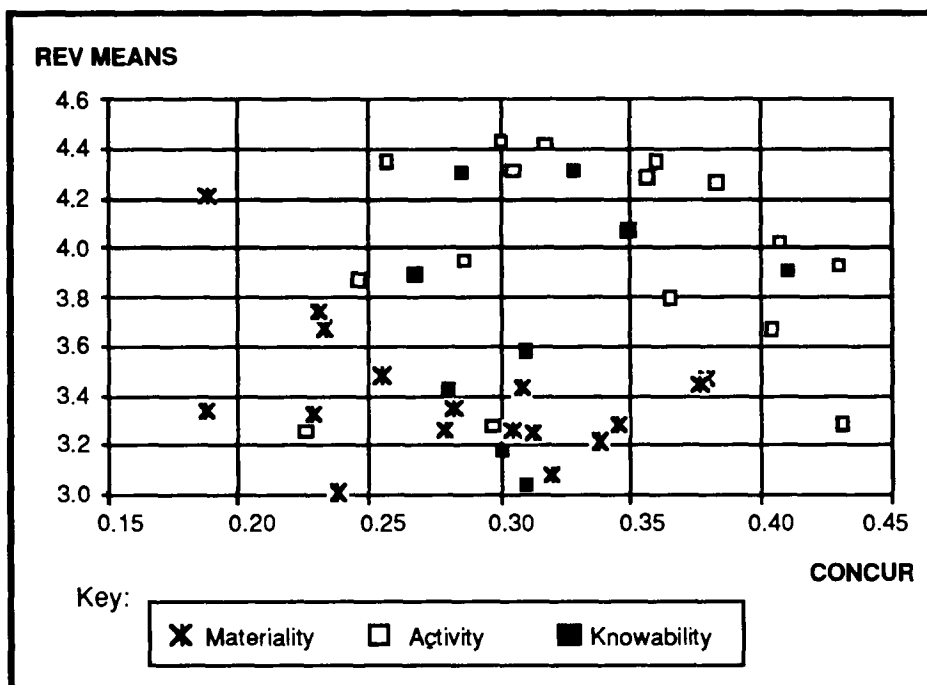

Figure 7.9: Reversed Means vs Concur plot for all data with categories exemplified

#### 7.4.2.3 How are students thinking?

To obtain further insight, the 44 variables were factor analysed using Orthotran/Varimax method. The best solution has 15 factors, which does not mean a great deal of simplification in the data as a whole. As has been already stressed in Section 6.2.3.3.2 of the previous chapter, the reasons for considering this result as due to chance are weakened provided that there is some natural interpretation of the factors and that the result of the Bartlett sphericity test enables one to reject the idea of no structure. In this case it gives  $\chi^2=3219.76$  for 989 degrees of freedom which corresponds to  $p \sim 0.0001$ , which enables one to reject the hypothesis of no

structure. The factors loadings are shown in Appendix 7.2. The interpretation of the factors, summarised in table 7.6 was as follows. Question mark symbols indicate factors whose interpretation seems least secure.

FACTORS	INTERPRETATION
Factor 1	Destructive Power
Factor2	Able to be Seen
Factor3	Substance-Like
Factor4	Natural Existence
Factor5	Permanence
Factor6	Dynamic (?)
Factor7	Active Energetic
Factor8	Dispersed (?)
Factor9	Can be Managed (?)
Factor10	Perceptible
Factor11	Abstract Existence
Factor12	Familiarity (?)
Factor13	Able to be Understood
Factor14	Dangerously Active
Factor15	Able to Move

Table 7.6: Interpretation for factors derived from factor analysis on data from all schools for all presentations

According to the proposed interpretation, factor 1, labelled **destructive power**, appears to relate to scales *strong vs weak, destructive vs creative, harmful vs beneficial, dangerous vs safe, productive vs destructive, secure vs risky, uncontrollable vs controllable* and *useful vs useless*. Factor 2 was interpreted as **able to be seen** and corresponds to loadings on scales which include *material vs immaterial, amorphous vs has shape, solid vs fluid, intangible vs tangible* and *invisible vs visible*. Interpreted as a collection of properties which would characterise the concepts as **substance-like**, factor 3 brings together *divisible vs indivisible, detectable vs undetectable, not composed of particles vs composed...* and, also, *powerful vs powerless, ordinary vs special, complex vs simple* and *material vs immaterial*. The fourth factor had high loadings on *ordinary vs special, natural vs artificial* and *has to be made vs grows by itself* and was thought to relate to a **natural existence**. “**Permanence**” was the name given to the fifth factor, which relates to the following scales: *momentary vs eternal, brief vs lasting* and *permanent vs transient*. More difficult to interpret because it presents high loadings only on *dead vs alive* and *passes through objects vs doesn't...* and, perhaps, *divisible vs indivisible* was factor 6. It was thought of as connected with a dynamic (active) character. More clearly, the high loadings on *passive vs active, energetic vs inert* and *powerful vs powerless* may justify the interpretation of factor 7 as relating to an **active energetic** character. Factor 8 relates to a set which includes

*spread vs located, permanent vs transient* and *acts by contact vs acts at a distance*, and was interpreted tentatively as relating to a **dispersed** character. The ninth factor is difficult to interpret, but can be seen as a possibility of **being managed** as its higher loadings are *stable vs unstable* and *known vs unknown*. Factor 10 was interpreted as connected to being **perceptible** and contains *perceptible vs imperceptible, invisible vs visible* and *uncontrollable vs controllable*. The eleventh factor was interpreted as relating to a **real existence** because of high loadings on *is always there vs comes and goes, light vs heavy* and *abstract vs concrete*. The twelfth factor probably relates to **familiarity** but it may well be a case of a single variable factor as it is highly loaded only on *familiar vs unfamiliar* and, less strongly, on *frequent vs rare*. Factor 13 was interpreted as related to being **able to be understood** because of the high loadings on *difficult vs easy* and *known vs unknown*. Factor 14 was identified as connected to a property of being **dangerously active**, being highly loaded on *makes other bodies radioactive vs doesn't..., can be measured vs cannot..., secure vs risky* and *divisible vs indivisible*. Finally, factor 15 because of high loadings on *still vs moving* and *moves by itself vs has to be carried about* received the label of **able to move**. Factors loadings are given in appendix 7.2.

These results can be understood as an indication that students' views on any concept tend to be complex and can embody inner contradictions and inconsistencies. In other words, 15 uncorrelated factors say that perceptions are *not simple* though the interpretations *do*, however, group naturally under the three main categories materiality, activity and knowability.

Firstly, considering the heading *Materiality* it is possible to interpret factors 2 (**Able to be seen**) and factor 3 (**Substance-like**) as one natural division which is related to the fact that material things are, in general, visible and have some shape. Factor 5 (**Permanence**) can also be seen as an aspect of a material character as well as factor 11 (**Abstract existence**). Still relating to materiality are factors 4 (**Natural Existence**) and Factor 8 (**Dispersed**). Secondly, *Activity* appears to be considered under different perspectives, namely **Destruction** (factor 1), perhaps a **Dynamic character** (factor 6), **Energy** (factor 7), **Danger** (factor 14) and **Movement** (factor 15). This division seems likely to be related to some kind of knowledge both of effects of exposure to radiation and of how radiation propagates. Thirdly being **Able to be managed** (factor 9), **Perceptible** (factor 10), **Familiar** (factor 12) and **Able to be understood** (factor 13) relate in



different ways to *Knowability* in the sense the concepts can be seen as existing in nature or it being controlled, or detected and measured.

Such factors are dimensions along which students seem to be thinking about radiation, radioactivity and radioactive material. We also have to look at which pole of each factor students actually tend to choose. Thus the general picture of the results could be summarised by saying that, taking the actual polarity of their choices (as shown in table 7.7), the concepts of radiation, radioactivity and radioactive material are seen mostly as follows:

IS	UNSURE	OPPOSED VIEWS
Destructive	Substance-like	Able to be seen
Dynamic	Permanence	Natural Existence
Active	Dispersed	Able to be understood
Unfamiliar	Can be managed	
Dangerously Active	Perceptible	
	Real Existence	
	Able to move	

Table 7.7: Students' choices across factors (data derived from Real Means vs Concur plot by scales on factors).

Thus, the general picture of students' views on each factor is something essentially destructive, dangerous, active and unfamiliar. Attributes students are most unsure are those concerning aspects related to the concepts' real existence, material nature and their autonomy. Nevertheless, according to their preferences, it is more likely they would take a substance-like view. They also hold opposing views as to whether radiation, radioactivity and radioactive material would exist in nature, though there may be a slight tendency to prefer a view which characterises them as artificial. Students also disagreed in relation to the possibility of the concepts be seen or understood.

#### 7.4.2.4 Differences Due To Presentation

The question of whether the ambivalences in students' choices relate to answers given to the different presentations of the questionnaire is open to inspection.

It will be seen that differences in responses which are due to presentation are few. However, the differences that exist appear to resolve some of the ambiguities

present in the discussion of the overall results. By looking at the correlations between the means of each scale for the different presentations, it is possible to have an idea of how similar responses given for the three different presentations are.

	RN	RY	RM
RN	1		
RY	.961	1	
RM	.929	.885	1

Table 7.8: Correlations for means of RN, RY and RM presentations

Comparing the values of the reversed means for each scale across different presentations, it can be seen that nine out of the first ten scales ranked in descending order of their reversed means is the same for all presentations. These scales, all but one related to **activity**, are: *makes other bodies radioactive vs doesn't make...*, *secure vs risky*, *energetic vs inert*, *strong vs weak*, *dangerous vs safe*, *detectable vs undetectable*, *passive vs active*, *powerful vs powerless* and *complex vs simple*. Scales which have low values for their reversed means are not the same for all presentations. Inspecting the last ten scales in the same rank of descending order of reversed means, only three, namely *natural vs artificial*, *acts by contact vs acts at a distance*, *uncontrollable vs controllable*, are common to the three presentations. The remaining scales relate mostly to the category previously labelled **materiality** and differ for each presentation. In the case of radiation they relate mainly to its natural existence whereas the aspect that predominates in the radioactivity presentation concerns a substance-like or particulate character. In the case of the radioactive material presentation most of them concern primarily being visible and having mass. Thus, overall, it seems that a dangerously active character is shared by the three concepts whilst, some, differentiations start to be made when their materiality is evoked.

As far as concurrence is concerned students present more diverse opinions in the cases of the radiation and of the radioactivity presentations. If scales are ranked in descending order of rate of concurrence, it is possible to see that five out of the first ten scales are the same for the three groups. They are: *harmful vs beneficial*, *productive vs destructive*, *destructive vs creative*, *stable vs unstable* and *difficult vs easy*. Again most of them relate to **activity**; only one being related to

which the group does not concur. Out of the ten last scales of the same rank, four, all concerning the **materiality** category, are the same for all groups, namely *amorphous vs has shape, material vs immaterial, not composed of particles vs composed ... and can be measured vs cannot be measured*. They differ in so far as they are not sure of radiation being visible or invisible and of it to be able to move. The controversy as far as radioactivity is concerned relates to it being perceptible and tangible. Finally, when it comes to radioactive material doubts are about activity both of itself and on others.

In summary, radioactive material is the presentation in which the group concurs most and that presents the highest values for the reversed means in each scale. In fact, overall, the pattern of choices in the cases of the radiation and of the radioactivity presentations tends to be very similar whereas the radioactive material presentation is somewhat different from the other two. Although there is a great deal of variability in students' choices and, therefore, it is not possible to identify many cases where differences between means correspond to sharp distinctions, there seems to be a consistent pattern which depicts categories along which a differentiation between radioactive material and the other two is likely to have been made.

In order to test for statistical significant differences between means of all scales for the three groups, t-tests were conducted. Results are shown in Table 7.9 and cases in bold correspond to the few cases where the hypothesis of no difference between the means can be rejected.

STUDENTS ANSWERING ABOUT RADIOACTIVITY

SCALES	RN - RY		RN - RM		RY - RM	
	t	df	t	df	t	df
<b>Material vs Immaterial</b>	<b>-2.828</b>	<b>225</b>	<b>-2.677</b>	<b>212</b>	<b>5.587</b>	<b>220</b>
Momentary vs Etemal	-0.715	225	-1.467	210	-0.769	217
Complex vs Simple	1.394	209	0.636	212	-0.737	208
Strong vs Weak	-0.289	225	0.574	211	0.827	220
<b>Amorphous vs Has shape</b>	<b>0.650</b>	<b>225</b>	<b>-2.376</b>	<b>211</b>	<b>-3.017</b>	<b>216</b>
Brief vs Lasting	0.193	222	-1.123	212	-1.381	219
<b>Ordinary vs Special</b>	<b>-0.072</b>	<b>225</b>	<b>-3.261</b>	<b>210</b>	<b>-2.443</b>	<b>218</b>
Passive vs Active	0.380	225	-1.106	212	-1.457	220
<b>Solid vs Fluid</b>	<b>0.120</b>	<b>225</b>	<b>2.962</b>	<b>212</b>	<b>2.828</b>	<b>219</b>
<b>Is always there vs Comes and Goes</b>	<b>-1.799</b>	<b>225</b>	<b>0.498</b>	<b>209</b>	<b>2.443</b>	<b>219</b>
Natural vs Artificial	-0.912	225	0.506	202	1.318	210
Energetic vs Inert	-0.202	221	1.197	207	1.488	220
Spread vs Located	0.920	225	0.061	212	-0.867	220
<b>Frequent vs Rare</b>	<b>-1.594</b>	<b>223</b>	<b>-2.621</b>	<b>212</b>	<b>-1.120</b>	<b>216</b>
<b>Destructive vs Creative</b>	<b>1.896</b>	<b>223</b>	<b>2.819</b>	<b>212</b>	<b>0.979</b>	<b>219</b>
<b>Has to be made vs Grows by itself</b>	<b>2.194</b>	<b>224</b>	<b>1.753</b>	<b>210</b>	<b>-0.309</b>	<b>213</b>
<b>Light vs Heavy</b>	<b>1.267</b>	<b>223</b>	<b>-2.861</b>	<b>212</b>	<b>-4.215</b>	<b>216</b>
Stable vs Unstable	0.433	223	1.292	212	0.905	217
Harmful vs Benefitious	1.304	224	1.264	212	0.000	217
<b>Powerful vs Powerless</b>	<b>1.993</b>	<b>214</b>	<b>1.493</b>	<b>212</b>	<b>-0.426</b>	<b>212</b>
Not composed of particles vs Composed...	1.025	225	-0.34	212	-1.378	220
<b>Still vs Moving</b>	<b>-0.382</b>	<b>218</b>	<b>2.119</b>	<b>204</b>	<b>2.585</b>	<b>192</b>
Dangerous vs Safe	1.051	222	1.307	211	0.342	212
Productive vs Destructive	-1.007	224	-0.639	211	0.32	214
Divisible vs Indivisible	-0.360	220	-0.768	212	-0.477	216
Permanent vs Transient	-0.405	225	1.441	209	1.796	215
Secure vs Risky	0.546	225	0.774	199	0.269	210
Uncontrollable vs Controllable	0.729	219	1.578	212	0.944	215
Detectable vs Undetectable	-0.351	225	0.923	209	1.27	216
Useful vs Useless	-0.910	225	0.166	212	1.062	219
Increasing vs Decreasing	-0.384	225	-0.925	212	0.002	220
<b>Intangible vs Tangible</b>	<b>0.190</b>	<b>233</b>	<b>-4.162</b>	<b>208</b>	<b>-4.449</b>	<b>209</b>
Difficult vs Easy	0.014	225	0.357	211	0.334	219
Dead vs Alive	-1.615	217	0.254	212	1.892	210
<b>Invisible vs Visible</b>	<b>3.250</b>	<b>213</b>	<b>-2.888</b>	<b>210</b>	<b>-6.248</b>	<b>198</b>
Familiar vs Unfamiliar	1.642	225	0.796	207	-0.777	218
Passes through objects vs Doesn't pass...	-0.568	225	-0.983	210	-0.447	215
Perceptible vs Imperceptible	-2.981	225	-1.861	212	1.155	220
Moves by itself vs Is carried about	-0.053	225	<b>-2.938</b>	<b>212</b>	<b>-2.865</b>	<b>220</b>
Known vs Unknown	0.300	225	0.167	211	-0.124	218
<b>Abstract vs Concrete</b>	<b>2.640</b>	<b>217</b>	<b>-1.852</b>	<b>211</b>	<b>-2.059</b>	<b>187</b>
<b>Makes others radioactive vs Doesn't ...</b>	<b>1.640</b>	<b>211</b>	<b>-0.525</b>	<b>206</b>	<b>-2.059</b>	<b>187</b>
<b>Acts by contact vs Acts at a distance</b>	<b>0.768</b>	<b>224</b>	<b>-1.213</b>	<b>211</b>	<b>-1.986</b>	<b>216</b>
<b>Can be measured vs Cannot...</b>	<b>0.919</b>	<b>219</b>	<b>-1.001</b>	<b>212</b>	<b>-2.009</b>	<b>216</b>

Table 7.9: t-tests for statistical significant differences between means for all scales in the three presentations (bold type indicates statistical significance at a 5% level).

These differences are illustrated for some scales where the analysis found significant differences to exist, in figures 7.10 and 7.11. Numbers shown in figures 7.10 and 7.11 refer to the following scales: (1) material vs immaterial; (5) amorphous vs has shape; (9) solid vs fluid; (10) is always there vs comes and goes; (16) has to be made vs grows by itself; (17) light vs heavy; (32) intangible vs tangible; (35) invisible vs visible; (41) abstract vs concrete; (42) makes vs doesn't make other bodies radioactive.

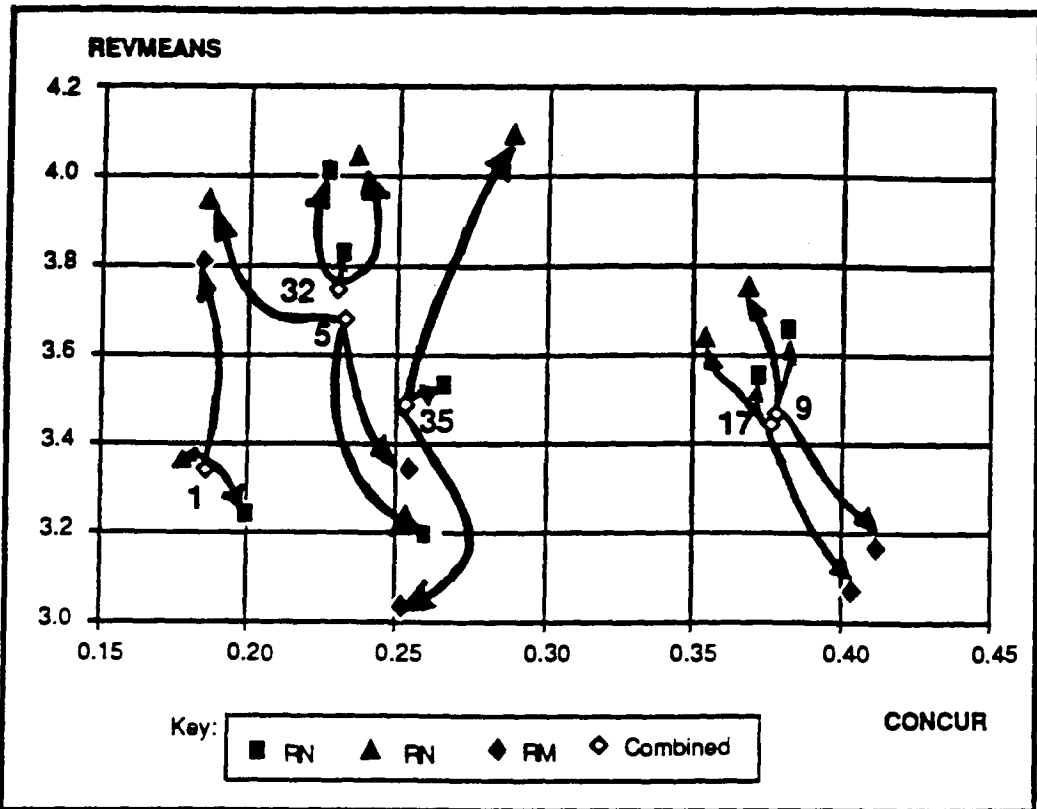

Figure 7.10: Reversed Means vs Concur plot selected scales across presentations as compared to overall totals

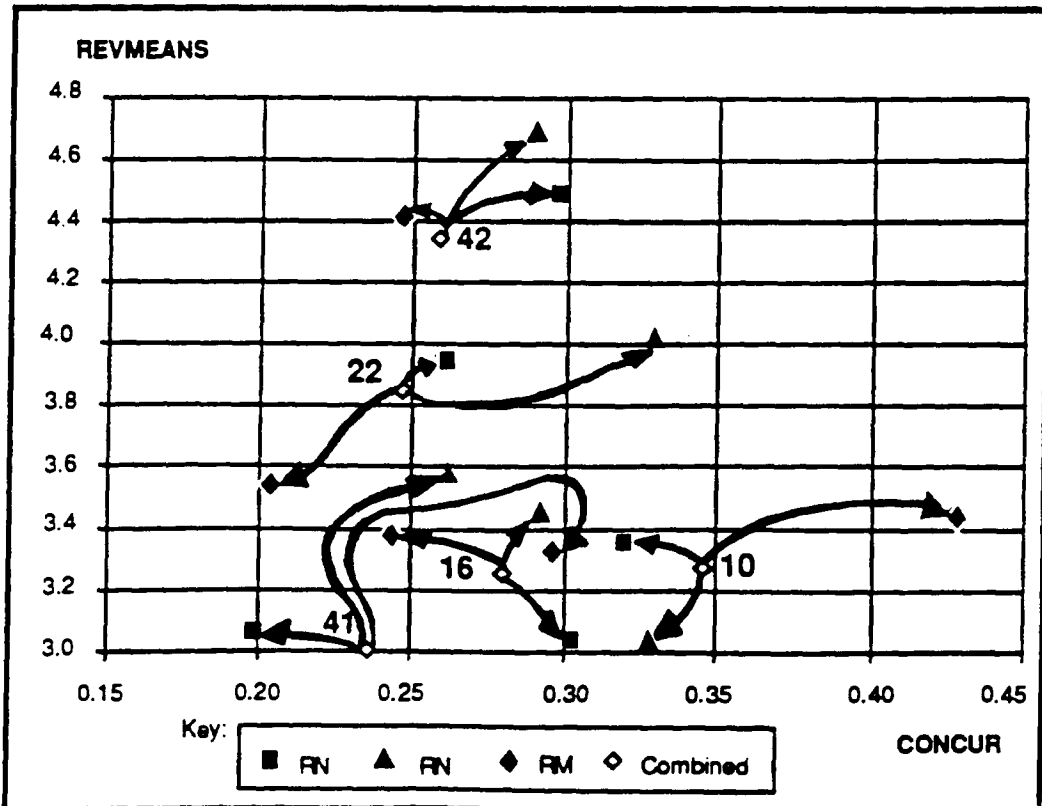

Figure 7.11: Reversed Means vs Concur plot for selected scales across presentations as compared to overall totals

Cases in which responses given to radiation (RN) and radioactivity (RY) tend to be similar to each other but different to those given to radioactive material (RM) are: *material vs immaterial* , with RM being more like material than the other two; *solid vs fluid* , with RM less like fluid; *always there vs comes and goes* , with more undecided as to whether RM could be seen as something that is always there; *frequent and rare*, as RM tends to be regarded more like rare while students remain unsure about RN and RY; *destructive vs creative*, with RY being more destructive than RM; *has to be made vs grows by itself*, with RY slightly more like something that has to be made; *light vs heavy* , with RM notably less like light; *powerful vs impotent* , with RY being more powerful than RN; *still vs moving*, as most of responses say RN and RY are more like moving though with some disagreement; *intangible and tangible* , with RM less like intangible and *visible and invisible* , with RM less like invisible; *abstract vs concrete*, where RY tends to be more like abstract than the other two; *makes other bodies radioactive vs doesn't make...* , with RY being more likely to make other bodies radioactive than RM; *acts by contact vs acts at a distance*, as for RY they are most unsure while holding opposing views to in the case of RM and; *can be measured vs cannot be measured*, for RY seems to be more liable to be measured than RM. In all cases results for RN and RY presentations tend to be very similar to one another and, yet, different from RM in so far as it is much more strongly associated with properties related to the materiality category such as tangibility and permanence and that it is regarded as more like material. Yet, it also appears to be the case that students have a more generalised view about the concept of radiation as they admit it is less destructive (as opposed to creative) and that it may be more concrete than radioactivity.

Apart from those already mentioned above, scales which present very similar value of reversed means as well as a similar degree of concurrence and, therefore, do not allow any discrimination among the concepts, are: *useful vs useless* , with students undecided between the two poles in all presentations; *passes through objects vs doesn't pass...* , for they, although with a lower degree of concurrence, more often select the first pole; *known vs unknown* , where there is a slight tendency for selecting "known" though the general picture in all presentation groups is more like half of the subjects selecting the central point of the scale while the other half is undecided between the two extremes.

To sum up briefly it can be said that if any differentiations among the three concepts are to be made they are more likely to be made between the concept of radioactive material and the other two. Furthermore these distinctions may be mostly related to

properties somehow connected with the material or immaterial nature of the concepts as all seem to share an active character and offer a similar level of difficulty as far as their intelligibility is concerned

This point is, perhaps, best illustrated by comparing the values of the correlations of the answers given to the scales both as a whole and separated by presentations. Looking at the correlations between the means of all scales for the three different presentations, it is possible to have an idea of how similar responses given for the three presentations the are.

If correlations for the scales now separated according to the three categories, namely, materiality, activity and knowability are compared, it is possible to see that they do not differ in the cases of activity and knowability for any combination of presentation. Nevertheless, the correlations tend to be lower in the cases where both radiation and radioactivity are compared with radioactive material in the cases of materiality.

	RN	RY	RM
RN	1		
RY	.961	1	
RM	.929	.885	1

Table 7.10 : Correlations for all scales

	RN	RY	RM
RN	1		
RY	.890	1	
RM	.754	.554	1

Table 7.11: Correlations for Materiality scales

	RN	RY	RM
RN	1		
RY	.992	1	
RM	.969	.972	1

Table 7.12: Correlations for Activity scales

	RN	RY	RM
RN	1		
RY	.956	1	
RM	.965	.968	1

Table 7.13 : Correlations for Knowability scales

One question which remains unanswered is that of whether two opposite views can coexist, that is, whether the same subject is likely to admit two conflicting behaviours for the same entity, or, whether it is the group that hold opposite views and, in this case, it is the very properties or behaviours of the concepts that are contentious.

This will require an examination of how individuals respond to scales which are related to the same category and that show a mean score near 3 (which indicates that either the central point of the scale was mostly chosen or that both extremes were equally chosen). The cases selected for an example were the following scales from the materiality category: *material vs immaterial*, *not composed of particles vs composed of particles*, *intangible vs tangible* and *abstract vs concrete*. Figures 7.12, 7.13, 7.14, 7.15, 7.16, and 7.17 show counts for all combinations of those scales. It is possible to see that, in general, answers tend to contain inner contradictions, in particular in the cases of the radiation and of the radioactivity presentations. Examples of the such contradictory views are radioactivity seen both as *composed of particles* and, at the same time, *intangible* and, radiation being *intangible* but *concrete* too. On the other hand, answers given to the radioactive material presentation are less likely to contain inconsistencies of that type, as answers given to these scales in this presentation suggest that it is more often and consistently viewed as *material* and *concrete*. The cases in which the group actually holds opposite views, like in *material vs immaterial* as compared to *abstract vs concrete*, for the radiation presentation, are, nonetheless, very few.

RN	Material	Both	Immaterial
Not Particles	6	1	6
Both	7	3	3
Particles	39	16	29

RY	Material	Both	Immaterial
Not Particles	10	0	9
Both	6	1	7
Particles	23	14	48

RM	Material	Both	Immaterial
Not Particles	8	0	4
Both	5	0	3
Particles	57	11	17

Figure 7.12: Totals for scales Material vs Immaterial and Not Composed of Particles vs Composed of Particles for all presentations.

RN	Material	Both	Immaterial
Intangible	28	15	27
Both	14	4	7
Tangible	10	1	4

RY	Material	Both	Immaterial
Intangible	26	11	44
Both	5	4	10
Tangible	7	1	10

RM	Material	Both	Immaterial
Intangible	28	4	11
Both	19	6	6
Tangible	22	2	7

Figure 7.13: Totals for scales Material vs Immaterial and Tangible vs Intangible for all presentations.



STUDENTS ANSWERING ABOUT RADIOACTIVITY

RN	Material	Both	Immaterial
Abstract	11	11	23
Both	13	5	4
Concrete	28	4	11

RY	Material	Both	Immaterial
Abstract	23	8	41
Both	7	3	10
Concrete	8	5	13

RM	Material	Both	Immaterial
Abstract	11	4	11
Both	25	5	4
Concrete	33	3	9

Figure 7.14 : Totals for scales Material vs Immaterial and Abstract vs Concrete for all presentations.

RN	Not Particles	Both	Particles
Intangible	8	8	54
Both	1	4	21
Tangible	4	2	9

RY	Not Particles	Both	Particles
Intangible	11	7	63
Both	2	4	12
Tangible	6	2	10

RM	Not Particles	Both	Particles
Intangible	4	4	36
Both	3	3	25
Tangible	5	1	25

Figure 7.15 : Totals for scales Not Composed of Particles vs Composed of Particles and Tangible vs Intangible for all presentations.

RN	Not Particles	Both	Particles
Abstract	3	6	36
Both	5	3	14
Concrete	5	4	34

RY	Not Particles	Both	Particles
Abstract	11	6	55
Both	5	2	13
Concrete	7	6	17

RM	Not Particles	Both	Particles
Abstract	1	3	22
Both	5	2	27
Concrete	6	2	36

Figure 7.16: Totals for scales Not Composed of Particles vs Composed of Particles and Abstract vs Concrete for all presentations.

RN	Intangible	Both	Tangible
Abstract	36	7	3
Both	12	8	2
Concrete	23	10	10

RY	Intangible	Both	Tangible
Abstract	54	9	9
Both	11	7	2
Concrete	16	3	7

RM	Intangible	Both	Tangible
Abstract	15	4	7
Both	13	14	7
Concrete	15	13	17

Figure 7.17 : Totals for scales Intangible vs Tangible and Abstract vs Concrete for all presentations.

### 7.4.2.5 Differences between Schools

Differences between schools were few. Correlations between the mean score for each scale in each school group are shown in Table ... and indicate a remarkable pattern of similarity. This pattern also remains the same if scales are separated according to the materiality, activity and knowability categories.

	PS	MS	NS
PS	1		
MS	.899	1	
NS	.897	.940	1

Table 7.14: Correlations for all scales in different school groups.

Statistically significant differences were found only for a few scales. In most cases they are differences between the responses given by the private school group and the other two. In fact, responses from the morning shift group and the night shift group tend to be very similar. The scales for which significant differences were found were *amorphous vs has shape*, *is always there vs comes and goes*, *destructive vs creative*, *harmful vs beneficial*, *productive vs destructive*, *uncontrollable vs controllable*, *detectable vs undetectable*, *useful vs useless*, *can be measured vs cannot be measured*.

Examining the choices made by each group, it seems that the private school group admits more relativism, that is, concepts may be seen more often by the same subject as both *useful* and *useless*, *productive* and *destructive*, *harmful* and *beneficial*. In the other scales where significant differences were found to exist, the pattern of choices of the night shift group is different from the others as they appear to be more unsure of concepts being either *amorphous* or *having shape* and also in doubt of them being more like something that *is always there* or that *comes and goes*. The night shift group also hold opposed views in relation to the other scales more often than the other two.

These differences are illustrated in figure 7.19, where the position of each of the scales mentioned above for each presentation is shown in relation to its correspondent for the whole set of data. Scale numbers are as follows: (5) *amorphous vs has shape*; (10) *is always there vs comes and goes*; (15) *destructive vs creative*; (28) *controllable vs uncontrollable*; (29) *detectable vs undetectable*; (30) *useful vs useless* and (44) *can ... vs cannot be measured*.

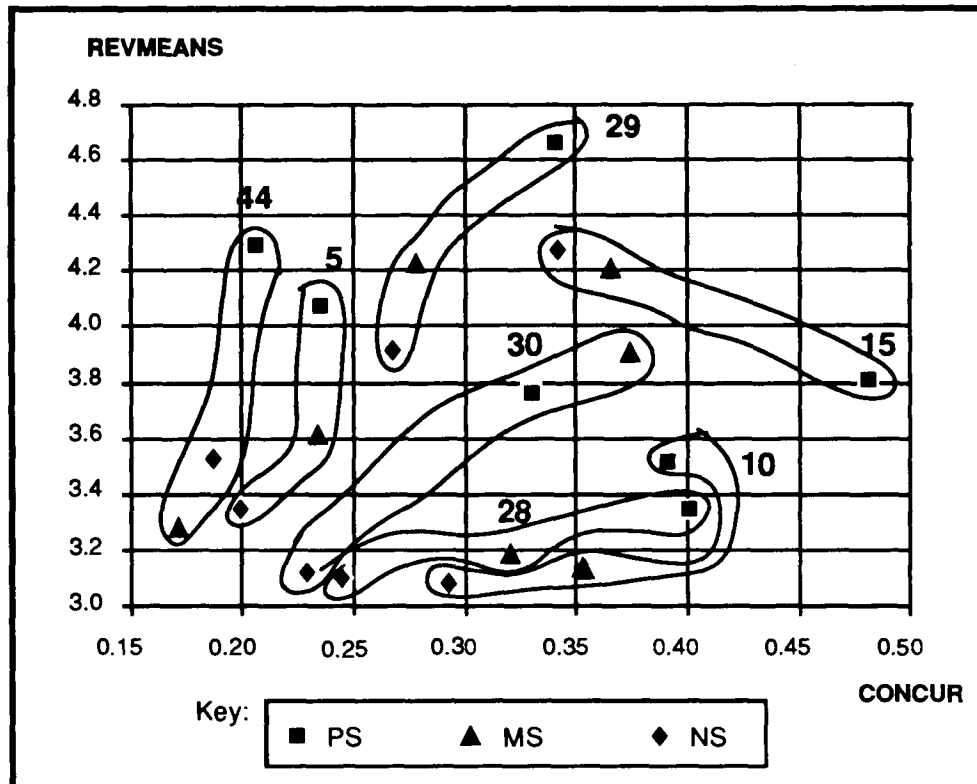

Figure 7.18: Reversed Means vs Concur plot for selected scales across school types.

## 7.5 SUMMARY OF RESULTS

Overall students say they do not know much about radioactivity related matters. Nonetheless they report some degree of interest in knowing more about it, especially in getting contextualised information (example, accident involving radioactive material) or information concerning immediate personal concerns about safety and how ionising radiation affects people.

Results on how the nature of the concepts of radiation, radioactivity and radioactive material are perceived by the students can be summarised as follows. Firstly, there was no evidence of either a clear-cut differentiation between the concepts or of differences between answers given by students from different schools. Altogether, concepts appear to resemble to some kind of intangible active entity with may not be readily accessible to the senses. When inquired in more detail, this simplified overall picture, however, unfolds in a plurality of features. The most striking one, about which the whole group, in general, concur, is the strong association of all concepts with *danger*, *activity* and with something unfamiliar. They are unsure about the characteristics which have to do with concepts' *real existence* and *materiality*, holding opposite views about their *intelligibility* and *natural existence*.

The suggested possibility that students draw a distinction between radioactive material and the other two concepts, as suggested by the analysis of the associations different concepts would evoke (Question 1), is again present in the analysis of the characteristics and properties attributed to the concepts (Question 2), the pattern of choices for the materiality scales being very similar in the case of radiation and radioactivity and different from those for radioactive material.

---

---

## CHAPTER VIII

### STUDENTS TALKING ABOUT RADIOACTIVITY

---

---

#### 8.1 ORGANISATION OF THE ANALYSIS

In this chapter, the results of the interview study conducted with students will be described. As previously described, each session consisted of two main blocks of activity. The first one concerning *explaining* which required them to discuss two extracts from newspapers concerning events which were related to the accident of Goiânia and to give explanations about both the nature and some properties of radioactivity.

The discussion of students' explanations will be divided into two main parts: content of their explanations (*what how they talk about*) and possible forms of reasoning which seem to be behind these explanations (*how they think about it*).

#### 8.2 ABOUT THE INTERVIEWS

Altogether, 52 students from all school types were interviewed in 13 groups of four. There were seven groups from the morning shift of the public school and six from the night shift of the public school. The absence of data from the private group is due to the fact that there was a private school teacher strike in Rio de Janeiro at the time the data was collected, it was impossible to complete the number of interviews required in the private school group.

All students had formerly responded to the questionnaire (shown in Appendix 7.1). All groups were formed of students from the same school and, whenever possible, the number of boys and girls in the same group was kept equal. Interviews took place in the school library or in a classroom which happened not be used at that

moment. Interviews were normally conducted after school hours, except for night shift students who were usually interviewed during their normal school hours. All students who took part in the interview study accepted to do so on a voluntary basis. Each group was interviewed once and sessions lasted, on average, for 1 hour and 40 minutes. The first part of the interview usually lasted for 40 minutes and was followed by a ten minute break, after which the second part would last for approximately the same time. All interviews were tape-recorded, transcribed in full and translated into English by the researcher at a later stage.

### **8.3 ON ANALYSING THE TRANSCRIPTS**

The first phase of the interview, concerning explanations students could give for the nature of radioactivity and some of its properties, consisted of four sub-parts. They are: (a) a concrete recollection of the accident with Caesium 137 in Goiânia; (b) explanations of the contamination of distant bodies; (c) a discussion about the possibility of keeping nuclear waste safe and; (d) a discussion of how radiation affects the human body. The interview started with asking students what they could remember about the accident, and continued with the presentation of two pieces of news published in connection with the accident, which provided a basis for the discussion.

At this stage, the discussion provided data about (a) students' recollections of the accident and (b) their views about the nature and properties of radioactive materials.

It was possible to identify a variety of themes and contexts in the transcripts. The first step was to classify the themes or emphases of the discussion. "*What is said*" could be distinguished with respect to the *subject matter* and to the *causation* perceived to be involved. The subject matter relates to *entities, events* or *settings*. Thus, the subject of the discussion could differ in so far as it might concern a thing (for instance, an object, people or even a physical entity), or an event (which could then be characterised as a process or a state of affairs) or a setting (which could be an actual physical place or a "scenario" which would also embody elements related to social interactions and to the role and behaviour of actors involved in the situation). Reasons for things to happen or behave in a given way as well as the their consequent effects were also identified as an emphasis in some accounts.

So far as “*how it is said*” is concerned, it was possible to recognise several modes of talk, different standpoints from which things were said and different lines of argumentation which were followed. The modes of talk they commonly adopted were classified as being *factual*, *speculative* or *evaluative*. Factual accounts consisted of reports of the event and its related circumstances, which were as faithful as possible, and in some cases quite detailed, but, without including any expressions which denoted conjectures, judgements or concerns. Speculative accounts contained conjectures, hypotheses and propositions which seemed to be based not solely on factual information provided either by the actual news or by other members of the group, but on any kind of previous knowledge, for example. Evaluative was the label given to accounts which include judgements and opinions.

As far as points of view expressed are concerned, the reference taken could be either individual or social, that is, the object of concern in a “story” could be either the individual or a group. Furthermore, accounts could also bear a more personal or impersonal tone, as things could be expressed in the form of either a personal point of view or in the third person.

Similarly the lines of argumentation could be either grounded on expressions of concern (with, for example, reference to roles and responsibilities of authorities or claims for the need of information) or could concentrate more on expressing feelings such as condolences, sympathy or indignation about what happened.

Figure 8.1 shows schematically the distinctions within each dimension and the possible combinations between them in form of a systemic network (Bliss et al, 1983). It was possible to identify examples of these possible combinations of themes and contexts in the analysis. In fact factual and evaluative modes of discussion predominated in the “concrete recollection” and a more speculative tone was characteristic of answers given to questions about the nature and properties of radioactivity.

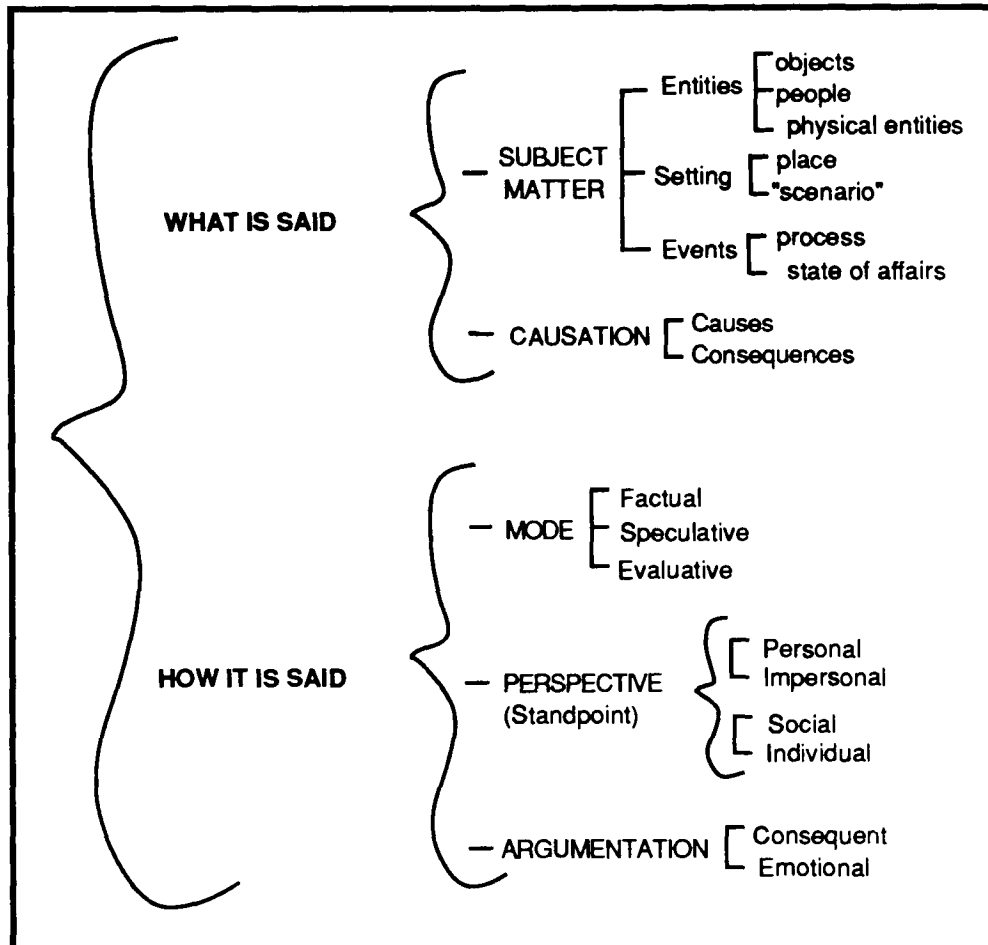

Figure 8.1: Proposed categories and distinctions used in the analysis of students' accounts.

The proposed dimensions of “*what they think*” and “*how they think*”, as illustrated in the network shown in figure 8.1, serve the purpose of helping in defining units of analysis. In order to illustrate how this was done in the case of both recollections and explanations, some examples are offered below.

In the recollections of a given group, it was possible to see that different aspects of the problem have been prioritised, that is, the event was regarded from different perspectives, by different people. It was also possible that several shifts both at the thematic and contextual levels could occur. For the purpose of the analysis, this was considered as a change in the unit to be analysed, that is, changes in both *what was being said* and *how that was being said*.

To illustrate these points, excerpts from an interviews are quoted and different possibilities of combinations of categories are exemplified.



## Example 1:

- 1 **A:** *I remember that... there was the owner of this junk-yard, who got this material, which was a sort of a capsule... of Caesium. He opened the capsule and became contaminated with a powder... that was solid... that was Caesium.*
- 2 **M:** *But he had to remove the lead...*
- 3 **J:** *And it seems that... he also took a piece home...*
- 4 **A:** *... and his son found it nice to play with and as he did that, he passed it along to everybody...*
- 5 **M:** *But it was sealed with lead... but he didn't know anything about [what] it [was] and removed it [lead]... but inside there was Caesium...*
- 6 **Z:** *But I would like to know how that ended up in their hands...*
- 7 **A:** *Yes, how?!*
- 8 **M:** *It belonged to a clinic... he then took it...*
- 9 **A:** *... and he found it very nice...*
- 10 **M:** *He wanted it as scrap-iron, because of the lead...*
- 11 **A:** *Yes, but it was not until the thing spread that did one discovered that it was Caesium...*
- 12 **J:** *Later, some people became ill... it was a big problem...*
- 13 **Z:** *And nobody knew anything...*
- 14 **I:** **What else do you remember?**
- 15 **A:** *Some people died ... yes, the daughter of the man from the junk-yard ...*
- 16 **J:** *... yes, she died soon after, poor little thing...*
- 17 **I:** **Do you remember why she died?**
- 18 **J:** *... she put it in her mouth ... how was it? Please tell me.*
- 19 **I:** **Yes I think what happened was that she had been playing with the Caesium and soon after she ate a sandwich, without having washed her hands or whatever. As a result she ended up ingesting a bit of it.**
- 20 **Z:** *And then ... other people ... people started to loose their hair ...*
- 21 **I:** **Who are these other people?**
- 22 **Z:** *People who became ill... because of it... the junk-yard owner gave it away to some people...*
- 23 **J:** *... yes, that's because of the effects of radiation. (MS1)*

The group appears to start by providing factual information about an object, namely the Caesium capsule (from lines 1 to 5), then Z, at line 6, changes both the subject and the mode of the discussion when she conveys reproof and surprise about the fact that some people were able to have access to the radioactive material. This change was analysed as re-focusing the discussion on an event viewed through constraints and implications concerning its social context (from 6 to 7). This is then developed into a scenario of the accident with a description of the role and relationships of actors, mainly in a factual mode (from 8 to 11). The emphasis is gradually changed so as to start enumerating effects and consequences, the mode of the discussion changes towards a more evaluative one, within a social perspective. Evidence for this are the indications of amazement and reproof expressed (from 12 to 14). A more emotional line of argumentation is pursued so as to contain expressions of grief or regret relating to consequences: the death of the junk-yard owner's child (from 15 to 16). The theme remains related to consequences until the end of this piece, with the interviewer providing details (repeating what had been published) about the contamination of the junk-yard's daughter with radioactive material, in a factual mode.

Another example of how different combinations of themes and contexts may be present even in the speech of the same person is as follows:

Example 2:

*A: I heard about it on TV. About a cloud, a radioactive cloud, that could reach us here...*

*I: Yes...*

*A: ... no... I don't know... yes, I think I am a bit confused. This has to do with that other accident in Germany, that which happened in Europe, when the reactor exploded... I was much more worried then. I remember now: it was in Chernobyl. I was worried about the people, about the children who would be born with problems. People were afraid because of the pasture and the animals becoming contaminated and they wouldn't be able to export things from there. The animals, the people, the milk... Then I became worried: could you imagine if they brought the animals, the cattle, the milk here? There was a ship with products coming to Brazil...*

*AE: Yes, that's right!*

*CLA: But that happened in Goiânia too. People were afraid of buying the products...*

**A:** *I hope it doesn't happen in Angra<sup>1</sup>. (MS4)*

In this piece, as the recollection of an event and its relating scenario develops, it is possible to identify factual, speculative and evaluative modes of expression.

In another example a student starts by talking about a scenario in a factual perspective as she tries to remember what happens. The subject then changes to contamination (seen here not so much as a process though) in a speculative way.

Example 3:

**M:** *A girl found a sort of a box with a radioactive substance inside it. She took it home and her father, who was badly informed, opened it and radioactivity was spread throughout the place. (MS5)*

Or with very specific details but less rigour:

**F:** *... it was Caesium she ate it... it was bright... she picked it in her hands and put into her mouth... (MS5)*

The same categories were also used to define units of analysis in the explanatory accounts given by students. In the example below, the group starts a factual description of how an entity (radioactive material) is stored away, from a mainly impersonal standpoint. It then changes to a speculation about the process of contamination and 'insulation', which ends up in a consequent argumentation done in an evaluative mode about their consequences.

**St:** *Well, the lead... you put it into containers... I think it will leak with time.*

**Se:** *No, it's the actual containers that are made of lead. It's Caesium that was put inside lead containers.*

**I:** *Right.*

**Se:** *But the city, this isolated area it was not [isolated] with lead, was it? Wouldn't it be the case of... Wouldn't there be the possibility of this irradiation leak? Would they have to put lead around the city as well?*

**A:** *It depends.*

**I:** *It depends on what?...*

---

<sup>1</sup>Angra (dos Reis) is the name of a city which is approximately 200 km away from Rio and where, in the last 15 years, three nuclear power stations have been built though technical problems of various sorts prevent them from operating in full capacity.

*A: It depends on the amount. In Chernobyl, it contaminates a huge part of the Soviet Union.*

*SI: Not only the Soviet Union but also a huge part of Europe.*

*E: It makes sense, doesn't it? Because if a very small ball contaminated such an enormous area [in Goiânia] the amount in Chernobyl was much bigger...*

*SI: But, over here, it contaminated because of people's ignorance. They even manipulated the material...*

*A: But in Chernobyl, people knew what to do and it was a disaster anyway. Knowledge did not extinguish the flames. (NS2)*

In general, units of analysis were not as small as in these examples. They were chosen to illustrate the procedure used to divide the text into units, as they contain instances of the categories and distinctions which characterised students' modes of talking.

## **8.4 A FIRST LEVEL OF ANALYSIS: WHAT DO STUDENTS SAY?**

### **8.4.1 CONCRETE RECOLLECTION**

Overall, it took students some time to feel relaxed and free to start exposing their own ideas about radioactivity. It was very common indeed that at the beginning of an interview students would give a warning about their lack of knowledge on the subject and apologise in advance if they were not able to answer the questions correctly. As the interview went along and it became clear that the objective was not simply to assess whatever knowledge they had, students felt more comfortable to express their own ideas and mutually encourage one another to speculate about the questions posed.

Few students produced total a coherent individual recollection. In fact individual accounts tended to be, in general, fragmented and superficial. Instead, recollection worked better as a collective enterprise with details being brought together by different members of the group so as to produce a reasonably complete account of the radiological accident of Goiânia. Little by little, the "story" of a capsule of Caesium being taken from an abandoned hospital and opened by two men who wanted just to make money out of it, develops, culminating in devastating consequences. The words "Caesium", "radioactivity", "contamination" as well as

circumstances like, for example, the capsule having been opened in a junk-yard, were frequently mentioned. Nonetheless there were also, though not so frequently, laconic responses which were not enriched by the contributions of the other participants in the group as, for instance:

**CLA:** *It was a radiation leak, wasn't it?*

**CLE:** *I don't remember very well. I remember that there was a big fuss about it a few years ago. They said the situation was under control, but who would say the opposite? Nobody guarantees.*

**AE:** *I remember it had something to do with Caesium, I don't know... I wasn't very interested in it at that time. (MS4)*

The accident was reported by most groups as a collection of facts about a social scenario. This kind of account often developed into a factual description of things including, sometimes, remarks which indicate a social concern. This illustrated by the example shown next.

**A:** *It was robbery.*

**E and Se:** *... yes, robbery.*

**A:** *The robbery of a medical device that eventually ended up in a junk-yard. There, they destroyed it, opened it, found it beautiful, it was bright in the dark...*

**Se:** *... they found a little blue ball and found it very beautiful, shiny... They took it home and stated playing with it.*

**SI:** *... it was their lack of knowledge, their own ignorance that led them to...*

**E:** *That's right... (NS2)*

At this initial stage of the group discussion, although contamination was often mentioned, the process through which it was believed to happen was not brought out in any detail. Some examples of this fact are:

**"A:** *It was opened and contaminated everything."* (NS2)

### 8.4.2 CONTAMINATION OF DISTANT BODIES

The contamination of distant bodies is explained in similar ways by the various groups. Two main lines of argument are generally proposed. In the first one, any agent such as radiation, radioactivity or Caesium powder is thought of as being responsible for the contamination; is viewed as being carried about in a variety of ways. Alternatively, the contaminating agent is thought of as having a means of travelling by itself. In the first case, the nature of the contaminating agent is actually particulate being frequently associated to a kind of powder. On the other hand, a more wave-like or ray-like nature tends to accompany accounts where contamination is related to the possibility of movement. Such views can be summarised as:

*“AD: Like a kind of dust... that [in order to] go from one place to the other, it needs the wind...” (NS5)*

*“Ve: No, I think it is more like a wave that gives off force and energy.” (NS3)*

These conflicting views and its consequent properties and behaviours were found in almost all groups, though the disagreement did not provoke a very contentious debate. Usually, views were exposed and there was an actual effort to make sense of one another's points. This, most often ended up in the opening of a wider range of possibilities and led the participants to balance conflicting views. It is interesting to point out that, in some cases, this debate ended due to lack of supporting information or any kind of previous knowledge which would serve the purpose of backing an argument.

The quotation below illustrates the typical polarised views in the discussion of one group, when asked to explain the contamination of the distant trees. The subject matter is physical entities and, predominantly, the discussion is run in a speculative mode.

*SI: Through the wind.*

*Se: Maybe because of the radiation...*

*I: Can you try and explain it better?*

*Se: In my opinion... I believe it was through the radiation...*

**SI:** ... but "allowed" <sup>2</sup> by the wind ...

**E:** I agree with that.

**I:** I don't think I follow what you are saying...

**Se:** The radiation... the radiation of the material...

**A:** You're saying that radiation gets in contact with the environment and...

**E:** ... it expands very easily, the irradiation. I think it has got a very easy expansion. So in a 100 meters radius, it is very easy for it to contaminate everything...

**A:** I remember... I don't know ... but I remember an explanation of our teacher ... it was a very fine powder, finer than dust... that could be easily taken by the wind... it wouldn't expand by itself, only carried by the wind or by people...

**I:** Right. It wouldn't have then the capacity of expanding by itself.

**A:** Yes.

**SI:** I don't think so... well, I don't know really.

**Se:** It's enough for it to be exposed in the atmosphere, there is the possibility of expanding.

**SI:** I'm not so sure.

**E:** As if it were "kitchen gas"..... if you leave it open, it is going to contaminate the whole house.

**A:** Isn't radiation a bit like radio<sup>3</sup>...?

**I:** What do you mean?

**A:** Like the waves... couldn't it be... because of its own energy?

**SI:** Positive waves...

**I:** So you think it has got its own energy...

**A:** It's not that I think... it does have it.

**I:** And the way it propagates...

**A:** Well it can be either way...

**I:** You mean: being carried or through its own energy...

**ALL SAY YES.** (NS2)

---

<sup>2</sup>The idea here is that the wind also makes it possible for "it" [the contaminating agent] to travel.

<sup>3</sup>In Portuguese the word "rádio" is used both to denote the chemical element Radium and "the radio", that is the well-known sound broadcasting apparatus.

Typical attempts at explaining the contamination of distant bodies would, in general, develop in the form of a polarised discussion about the nature of the “contaminating agent”, with its possibilities of moving around as well as its power or strength to affect surrounding bodies usually being seen as directly dependent on its nature. This example also shows that the polarised debate would not necessarily have a winner. Most of the students admitted points made by those who happened to defend a different stance and ended up compromising opposing views. This compromise is done at the expense of a more clear-cut definition of the nature of radioactive materials/radiation/radioactivity. This is also shown in the quotation shown next, where the group starts by explaining contamination but ends up discussing possible ways radiation propagates.

*F: I think it [contamination] occurred through the soil.*

*I: Can you explain it better?*

*F: When they isolated the area, the area that was highly contaminated, maybe they didn't check this other area, 100 meters away from it, so... it seems to me that they removed [a layer of] the contaminated soil, so many centimeters or meters deep, but maybe there was some contaminated soil left and it passed to the other trees...*

*I: What passed to the trees?*

*F: The substances passed along...*

*M: The radioactivity...*

*A: No, I think it was through the air... Well I don't know very well... Is there a radius of action for radioactivity?*

*M: Well, it spreads...*

*A: I believe it was carried by the air.*

*M: It spreads...*

*I: What do you mean, Marcelo?*

*M: It spreads by itself, it's nature is like that.*

*I: If this tape-recorder was made of Caesium would I be affected by it?*

*M: Of course.*

*I: Even if I am careful enough not touch it?*

*M: Yes, because you are close to it.*

*A: Yes, and with the help of the wind... it helps to carry the particles...*



**I: So this stuff that is carried is like particles...?**

**A: Yes, that's right. But to contaminate... there is no need to transport the particles**

**M: Exactly because the radiation spreads ... like rays... giving off rays...**

**A: It can be by transportation of particles but it contaminates the air too. So there's no need for transport of material... it contaminates the air and then goes by itself... (MS5)**

This example also suggests that whatever the contaminating agent may be like, contamination is related to the possibility of movement. Whatever the agent, it is seen as having to 'reach' whatever it contaminates, but this can be done equally across a space by rays, as through the transport of material.

In general, radioactive materials seem to be conceived by students as some kind of solid or gas which release radiation or radioactivity in the form of waves or rays. This was the closest they could get as far as a differentiation between the three concepts is concerned, as exemplified in the following quotation from the same student.

*"...radiation spreads... no matter how far radiation was from the trees... it spreads... well, if it was a kind of dust and they broke it into pieces, everyone picked it up, it might have been mixed with water, people touching things without having washed their hands, just like the girl who died.... (MS2, p.2)*

*"Well ... [this stuff that is carried about is] ...the radioactivity. I don't know but, my conception of radioactivity is... I think it is some sort of energy... maybe then that thing could spread all over... I can't explain it." (MS2, p.4)*

It seems that, for this student, there are two distinct entities namely a radioactive material which resembles dust and is carried about and radioactivity which is more like a kind of energy which spreads by itself<sup>4</sup>. This differentiation is illustrated by the quotations below:

**"AC: Yes, they put everything in a container made of lead so that the Caesium would not escape to the outside. People who dealt with it**

---

<sup>4</sup>Some evidence of this differentiation cannot be fully represented in the translation into English. Portuguese is a language where gender is determined and, therefore, adjectives, pronouns, etc have to agree with the subject be it masculine or feminine. As it happens, the words 'radiation' and 'radioactivity' turn out to be feminine whereas a 'material' is masculine. It is possible then to identify, in some cases, to which of the concepts students are making reference to. That was, however, impossible to be preserved in the English translation.

*had to wear special clothes ... It's funny, I've started talking about it and as I was talking I was able to remember more...*

**I:** *So, this was done so that Caesium did not escape to the outside...*

**AC:** *No, the radioactivity. Not the actual material Caesium but its radioactivity.” (MS2)*

**Fe:** *... it was transported...*

**Fa:** *No, the Caesium stayed there, but its radioactivity...*

**Fe:** *...the radioactivity released by it...*

**Fa:** *Yes, that's right, the radioactivity it released started affecting the environment. there was no transport of Caesium but rather, transport of radiation.” (MS3)*

**E:** *But the radioactive material is solid, isn't it? And isn't it the radioactive material, the solid material that contaminates, it's a kind of gas that expands and contaminates other areas.” (NS2)*

Nonetheless there are cases of situations where words are used interchangeably and denoting the same meaning. In the quotation below, for example, the word radioactivity is used to refer to something that is possessed by bodies instead of a property.

**Va:** *... they opened it and it contained radioactivity... (NS3)*

### 8.4.3 CAN WE KEEP IT SAFE?

In general students tend to think that it is very difficult and hardly ever possible to keep a radioactive material safe. A lot of extra care is needed, the use of “strong” materials being essential; however no one can be completely sure whether it is really safe and for how long. Caesium’s “strength” is much greater when compared to the soil’s but probably lower, when compared to lead’s. This explains why Caesium is able to pass through the soil but is actually blocked by lead. The need to bury it deep down in the soil and cover it with several layers of different materials is understood as a consequence of its huge “power of propagation”.

Some students suggested that the radioactive material's radiation (or radioactivity) could leak, like for example kitchen gas leaks, passing through narrow gaps and spreading all over.

In some students' views, Caesium is thought of as able to "propagate very easily". It is also seen as able to pass through objects, even through "strong materials", with lead possibly being an exception.

Others justified their answers by saying that objects adjacent to the radioactive material would become contaminated and, therefore, able to contaminate others too. In this view there is not necessarily any transport of material, though that is also another way contamination is perceived as to occur. The two basic kinds of justifications for the way contamination occurs, both grounded on the potential active contaminating power radioactive materials are thought to possess.

Caesium's power of contamination is also seen as very much dependent on the amount of existing Caesium. In many interviews the accident at Chernobyl and its disastrous effects were mentioned. When comparing the consequences of the two accidents, especially the radius of contamination around the two areas, it was often said that there was not much danger that areas in the outskirts of Goiânia would be contaminated, by contrast with what happened at Chernobyl, when even areas in Europe were affected, because the amount of Caesium was smaller than that at Chernobyl. This leads to extra care and precaution being needed in the case of storing large amounts of nuclear waste.

One interesting discussion that took place in various interviews was that concerning conservation. The need for shielding is sometimes linked to the fact that "it never stops", that is the activity of the radioactive materials, if not eternal, at least lasts for many years, constituting a permanent danger. This is illustrated in the quotation below.

*A: .... it could decrease but would never really stop. It would always be releasing that kind of gas. When people were buried they had to be buried in special coffins, made of concrete... I don't know exactly...*

*B: ... yes, that's right, and the place had to be sealed and isolated.*

*A: I think it never stops. because when they buried the victims they said that if one day that cement... in one day they dig up those people, the whole place would be contaminated. That's why I think it never stops.*

This quote also illustrates the view in which radioactive materials are seen more like a kind of “stuff” which is able to emanate radiation or radioactivity in the form of a gas (or rays or even vibrations).

#### 8.4.4 HOW DOES IT AFFECT THE HUMAN BODY?

Students say radiation/radioactivity can affect the human body both internally and externally. External effects are mainly connected to burning whereas vomiting and diarrhoea are seen as evidence of how it affects you internally. Many direct consequences of exposure to ionising radiation are also evoked. The most often mentioned are hair loss, cancer (types of) and deformities (hereditary diseases). These are also mentioned as a kind of symptom, that is, as indicators of exposure.

External effects are seen as provoked by rays that burn the cells. In this case radiation is likely to be associated with heat in as much as both are able to provoke burns. Again the radioactive material is somehow dissociated from the rays it is supposed to emanate. From some accounts it is quite clear that no direct contact is needed, for one to suffer the effects of radiation. A frequently evoked idea was that of x-rays which, in students' views, seem to share many properties in common with ionising radiations. A quite illustrative example is shown next.

*Ve: ... when the treatment is being done...*

*Va: ... when x-rays are being taken...*

*Ve: Yes, the material, the Caesium, is not put in direct contact with the person. The person stays a little bit far from it. The person feels only the effects...*

*J: ... only the heat...*

*R: ... a kind of rays...*

*Ve: Yes, but what happens is that... it causes a kind of burning, a kind of blister, like burning, because it burns the cells. For people who have to undertake treatment for tumours and such things... I saw my friend's boyfriend when he was doing his treatment and his skin ... because it was so thin ... it looked like as if it had been burnt. He had his treatment done with Cobalt. (NS3)*

There were also the internal effects which were mostly explained by use of expressions which were clearly derived from Biology lessons. Two broad questions were asked. How does it get into the human body? How does it affect the human body internally?

The ways it gets into the body are seen as various. One obvious way would be by touching a radioactive material. In this case according to some students, you would either become radioactive too or would become a "carrier" of the material. In both cases the person who touches it becomes able to contaminate others. Many students mentioned "ingesting", making a clear reference to the girl who ate some Caesium Chloride particles. Others said by "inhaling", saying it would get into the body easily through the respiratory passages. This is also seen as a very common way of getting contaminated because, as one student explains, there is not a way to avoid "... *breathing such air [full] of radiation... because the the air gets well into your body*". The "inspiration and expiration" processes would also help it to spread through the body through blood flow. In such view radiation is clearly associated to some kind of "stuff" which would circulate along the veins. Another way of it getting into the human body is seen as going through the pores.

On the other hand, there were also cases in which radiation was not seen so much as a kind of stuff that somehow gets inside the human body. The quotation below exemplifies a view which is consistent with an idea of radiation as a sort of immaterial influence which is compared, in this case, with the sun's rays. Nonetheless in such cases the process tends to be made more no more explicit than in the other cases where there was a direct appeal to known Biology classes and their familiar jargon.

*J: In the same way the body takes... from the sun rays... the sun... the sun strikes the skin, the pores absorbed it and the body transforms it into a vitamin, I don't know which... I don't remember exactly... but I think it's the same kind of absorption..." (NS1)*

Once inside the body, it is believed to cause a "disruption in the cells" or to "destroy the cells" "*like a disease. like a type of cancer. It starts somewhere, then it spreads to other organs...*" (NS2). It is also thought to destroy the affected person's antibodies, especially if they are young children, since their organisms are more fragile. Other possible things it would do once inside the body are "*to block the blood veins*" (NS1) and "*to prevent leucocytes to reproduce*" (NS1).

Despite having different views about the nature of radiation, that is, whether it would be particulate or wave-like, or perhaps material or immaterial, there is a point which is widely agreed by students, in general, namely that exposure leads necessarily to contamination. In other words, everybody, or everything, that was exposed to radiation/radioactivity is contaminated and, therefore, is able to contaminate others too.

#### **8.4.5 RELATED TOPICS**

During the interviews several related issues were frequently mentioned as problematic: *contamination, conservation and means of propagation.*

##### **8.4.5.1. Contamination**

Contamination through radioactivity was mentioned in all contexts in which questions were asked. It is thought to happen inevitably when either exposure to radiation takes place or one has had any kind of contact with a radioactive material.

The processes through which they say that a person or an object may become contaminated have been discussed earlier, and are:

- (i) *transmission of matter*: radioactive material is deposited on the surface (like a fine layer of dust on a table) or get inside an object so as to turn it into a secondary contamination source;
- (ii) *irradiation*: exposure to radiation/radioactivity provokes a chemical alteration inside the organism (for example, in a similar way through which sun rays are absorbed and transformed into a vitamin inside the human body).

Similarly to both other studies on the subject (Eijkelhof, 1990) and to results obtained in the quantitative study, the wide-spread belief that irradiation leads necessarily to contamination and that contamination would lead to death was often found across different groups. Moreover, students appear to have little, if any at all,

knowledge about other contexts of use or applications in which the two processes, viz., irradiation and contamination do not happen together as, for example, in the sterilisation of food or surgical material. A few students, however, doubted this straight correspondence between irradiation and contamination provided the *amount* of radiation/radioactivity was not too big. One example is:

*Fa: For example, if you have an x-ray taken the amount of radiation you receive is not enough to contaminate you. You go away and nothing happens. It's only if you are...*

*P: Yes, that's right! Because the people who were medicated, they were treated normally, without any special care. If they were irradiating it would be different.*  
(MS3)

Another example in which this view was also challenged was that of a student who posed a question about how it could be possible that some people who had had direct contact with the radioactive material and that, therefore had to have been necessarily contaminated, could be still alive (like the owner of the junk-yard). In this particular case this was counter explained by another participant of the group who raised the issue of *de-contamination*.

Contamination was regarded by many students as a process of unequivocal and irreversible effects, though the possibility of de-contamination was mentioned by few. Some students mentioned medicines which came from Chernobyl and were given to some victims of the accident at Goiânia, so as to diminish or eliminate effects. Others mentioned having heard something about the de-contamination of the place where the capsule was opened. In both cases nobody was able to describe in more detail how the process of de-contamination would take place (for example how such medicines would act inside the body). The removal of contaminated objects was suggested as a way of de-contaminating a place but, even then, that it would be necessary to wait for many years until the place could be inhabited again.

#### **8.4.5.2 Conservation**

At the first stage of the group interview, the issue of conservation arose in two contexts of discussion: (a) in explaining what happens to the activity of a source after it has started contaminating other bodies and; (b) when talking about the possibility of keeping radioactive materials (and radioactive waste) safe. In both

contexts, it is seen as a problematic issue leading to a polarised debate between members of the group who disagree about its (non) conserved nature.

As was seen earlier, radioactive materials are seen, in general, as a kind of solid (which may be powder-like) or gas which is able to emit invisible emanations (which would resemble a wave or rays). Such emanations, whatever their nature is conceived to be, are often referred to as the radioactivity or the radiation possessed by the (radioactive) material. Radioactive materials are also believed to contaminate others in various ways with students often referring to their power of contamination. This power is frequently seen as directly dependent on the “amount” of existing material and/or on the capacity (or potential) of giving off these invisible emanations.

According to most of the subjects, locking up a radioactive material in a container does not seem to allow radioactivity or radiation to build up, though it certainly “*becomes concentrated*”. The problem arises when an explanation of what happens to this power of contamination of a given source when, as in their words, “*it gets in contact with the environment*”, and is, therefore, able to contaminate other bodies. The kinds of answers are strongly dependent on the perceived nature of radiation/radioactivity/radioactive materials and on the ways contamination is believed to occur. The most common ideas are:

(i) *The stuff is used up but its effects may last for many years*: This kind of idea was present when students referred to the sort of genetic alterations some people who lived in either the vicinities of Chernobyl when the reactor exploded or Hiroshima and Nagasaki when the atomic bomb was dropped. The fact that deformities and high incidence of certain types of cancer can be detected up to the present time may be seen as an indication that even after the actual material has dispersed (or become inactive) the results of its interactions last for a long time.

(ii) *“Irradiation” loses energy as it propagates*: This view is consistent both with a particulate, cloud-like view and with a ray-like emanation view of radiation. In the first case, as the particles travel their “irradiation” is used up by the contamination of the air or other bodies it meets as it travels. In the second case, the rays lose intensity or energy (or force, for some students) as they travel along. In both cases radiation is seen as something radioactive materials possess either “incorporated” in themselves or as



something they give off, and the amount of material is thought to be something different from the amount of radiation it possesses, though the greater the amount the more radiation it possesses. The time span of a radioactive material activity seems to be regarded as finite though it is better expressed in a scale of years. In fact, this was the most frequent view across all groups.

(iii) *Radiation lasts forever*: According to this view, the potential power of contamination possessed by radioactive materials is timeless. This is justified by saying that this power of contamination remains the same no matter how many “contaminations” it has caused. This probably modelled on the way a viral contamination seems to occur, since many justifications were of the type “*the girl contaminated a lot of people and after that died, in fact she went on contaminating even after her death, she was like atomic waste*”.

The discussion about conservation was not systematic or coherent. In fact it was very common that participants would change their views during the discussion. Grounds and justifications for opinions were often not made explicit. In the example shown below, three students had different opinions about the (non)conserved nature of radiation/radioactivity and a fourth student did not express her views at all. In this case one of the students challenges the others to give examples of why they believed radiation would not last forever. Much of the argumentation is developed in a speculative mode with the subject matter being the behaviour of physical entities and human beings. At this point R. defends the position that radiation given off by radioactive materials is similar to waves which tend to lose what he called 'intensity'.

*R: Yes and I think that everything that becomes radioactive starts losing ...*

*I: Suppose this table becomes radioactive, will it give off waves as well?*

*R: Yes, but the intensity is lower.*

*J: I don't think so because the little girl contaminated a lot of people and died.*

*Ve: No, I think it will take many many years for this radioactivity to finish.*

*R: O.K. It will take long for it to stop but it will have force to ... ..*

**I: Juliana, do you think she was still radioactive when she died?**

**J: Yes.**

**I: Could she contaminate others after she was dead?**

**J: Yes, that's the case and that's why the [special] coffins, the lead, etc.**

**Ve: Yes, she died but she became nuclear waste.**

...

**Ve: But even after she was already dead the Caesium was still there, she was irradiating because the Caesium was still there.**

**J: So this thing that if I am contaminated and I pass it along to you and it decreases, it's not like that... it doesn't happen like that...**

**R: Hummm...**

**Va: No, if you are contaminated and ...**

**J: I pass it along to you, O.K.? ... does mine decrease?**

**Va: Well, mine is not as intense as yours.**

**I: Vânia, are you saying that you become contaminated...**

**Va: Yes, but at a lower level.**

**I: And what about her level? Is it the same or is it lower?**

**J: I think it stays the same. It contaminates everybody in the same way. It will be the same thing.**

**Va: No...**

**J: How is that possible then? Didn't her mother die? Didn't her father die? Everybody died!**

**Va: No...**

**J: What you (Vânia) are saying is: I am contaminated, I pass it to you, yours will be lower than mine...**

**I: But what about yours?**

**J: I think it's the same thing that hers.**

**Ve: What she (I) is asking is if your radiation is going to be the same after you have contaminated her.**

**J: It will. It will.**

**I: And she gains some that is ... compared to yours...**

**J: She will be the same as me.**

**I: The same. Vânia, you think that yours will be lower and hers [the one who contaminated you] ...**

**Va:** *The same. Stays the same.*

**Ve:** *I think that it can be a very small amount, minimum, but the person who passes it along ... it decreases... because... otherwise how in the end of many years would Caesium have lost its radioactivity?*

**J:** *But it didn't lose its radioactivity...*

**Ve:** *But it will, after many many years it will.*

**J:** *Does it lose or will it never lose? I think it will never lose.*

**Ve:** *Well, it gives off, gives off, gives off...*

**J:** *If it is like that,... well, this box had been kept for many many years. It was opened after a long time. It had been stored for a long time and it didn't lose anything... The box that was in the old man's bar... it had been there for a long time as well...*

**Ve:** *You need much longer... It's not a matter of 10 or 20 years... Maybe a century, two centuries...*

**J:** *So you agree with me, Vera.*

**Va:** *But this material was sealed, well stored...*

**J:** *That's exactly what I am saying, perhaps it was well stored, but it will never finish. I think it is something that never finishes.*

**R:** *In the case of the power stations, when the energy of the material is used up they throw it away... It is not recyclable...*

**I:** *But does it last forever or not?*

**J:** *I think it lasts forever.*

**Ve:** *I don't think so. (NS3)*

From this excerpt, it is quite clear that the discussion about conservation is far from being unproblematic. In fact, as was said earlier, it seems that students felt awkward about not having more information from which they could draw arguments to back their positions. Despite that, in some cases, the discussion was pursued in a speculative mode.

**A:** *... Can I ask you a question? What I would like to know is... suppose... why does an exposed material, I mean, that is in contact with the environment, it starts losing energy... but it releases energy to the environment, but it is locked up inside a box, so what I cannot understand is... how can it finish or... [how can it] run out of energy, if its energy is there, it's there with it...*

**I:** *What would happen to this energy?*

**A:** *Well, from time to time, this lead would have to be changed because it would become radioactive as well, because it is suffering a constant pressure, that cannot be helped, if it has got to release it [energy] anyway, then the lead will have to absorb it. It is like that: either energy stays locked (concentrated) or the lead becomes contaminated.*

**I:** *And then...*

**A:** *I don't know. I don't know how it can be. This energy... I can't understand. If it dies away with time... in order to worn out, it has to go somewhere. It's got to go somewhere, if it is the lead that contains the material, then... it will be... (MS1)*

In such a case the argument is pursued without any knowledge of radioactivity or of the properties of the lead. It is also firmly grounded on the assumption that irradiation leads necessarily to contamination. However, it presents an argument for conservation which is nicely developed and the paradox perceived (either it does not die away with time and stays concentrated or it goes somewhere, to adjacent bodies, and then the lead has to be changed) remains regardless of the nature radiation/radioactivity is thought to possess (particulate or rays).

Interestingly no comparison is made with any other kind of physical entity which would present the same characteristics as far as conservation is concerned. Apparently what seems to matter is the evidence of a real danger and definitive messages about its lasting power of destruction. There is also evidence that radiation/radioactivity has a kind of man-made/artificial nature, as in many cases the activity of a source at a given later time is thought to be lower than when it was first "fabricated".

#### **8.4.5.3 On the Need of a Medium for Propagation**

Discussion about (the need of) medium through which radiation/radioactivity would propagate was not frequent. It happened in two cases, in the context of analogies made between radiation/radioactivity and electricity/magnetism. In general, this sort of interaction is perceived by students as a *action-at-a-distance* type, with no need for a medium to propagate.

**A:** *Because it's energy and energy passes from one body to the other. So how can we explain that electricity is transmitted? Nobody, nothing carries it.*

**E:** *Nobody is carrying it, it passes through the conductors, through the wires.*

**A:** *It is indeed passing through something. And energy, it's in the air, isn't it? It's like magnetism...*

**I:** *In the case of magnetism... Suppose I have two magnets... how does it happen? I put one closer to the other and they are attracted or...*

**A:** *Yes, in this case there's nothing that conducts.*

**I:** *What do you mean by there's nothing that conducts...*

**A:** *I think it's only energy. It's their own energy through the poles.*

**I:** *And is it similar to what happens in the case of radiation?*

**A:** *No, but it [radiation] is an energy. It's like the energy of the sun. The sun is radioactive. Like the energy of the sun. Nobody, nothing brings it.*

Although there is not enough evidence to support any further interpretation, it would be very interesting to investigate how such discussion on the need for a medium for propagation might reveal students' ideas on the nature of space. As it happens, it appears to be the case that their idea of no necessary need for a medium entails a conception of space as continuous and independent of matter. In so far as the radioactivity/radiation is concerned, if they resemble at all any physical entity, that entity would be an electromagnetic wave.

### **8.5 A FURTHER LEVEL OF ANALYSIS: HOW DO STUDENTS THINK ABOUT IT?**

Apart from the actual content of explanations given, it was also possible to learn something about their form, about the way they were constructed and communicated and speculate about which forms of reasoning would appear to be used. In the next section, different types of reasoning will be described, with examples. There will be also reference to their content when discussing different modalities of explanation, so as to arrive at a more general picture of students' views on the subject.

## 8.5.1 TYPES OF REASONING

Several different types of reasoning appeared to be behind answers given. They are: (i) use of analogical reasoning; (ii) identifying similarities of effects as indicating similarities at the level of causes; (iii) deriving knowledge from social expectations; (iv) use of semi-quantitative reasoning; (v) knowledge about properties triggering assumptions about nature. They are described in the next sub-sections.

### 8.5.1.1 Analogical Reasoning

Some use of analogical reasoning was expected, because students were not expected to know much about the topic, so some sort of comparison would have to be made in order to provide, in a first approximation, a basis for thinking. Thus, in order to explain the nature or some properties of radiation/radioactivity/radioactive material, reference to other entities were made. In such cases the concepts were being modelled on the entity, the nature and behaviour of which were known. There were also cases in which analogies were used to explain processes through which radiation/radioactivity/radioactive material act. In such cases it is mechanisms and processes that are being modelled on already known ones. Analogies then could be analogies of nature or analogies of processes.

#### (i) Analogies of Nature:

Analogies of nature were mainly employed by students when differentiating the concepts of radiation and radioactivity and when they wanted to make explicit what was meant by a radioactive material. Analogies were mainly used either to illustrate a point or to help to express some kind of doubt. Very rarely were they used so as to develop or support an argument. Consequently, in certain cases, there was not much follow-up and comparisons served more often the purpose of finishing a discussion.

Grounds for accepting or dismissing analogies were also not very often made explicit though, in some cases, there were some hints, as in the example below. In this case different material entities are proposed and rejected later, using the criterion of visibility. They ended up deciding for a similarity with electricity based on the fact that both are only perceived by their respective effects.

**\*AP:** .. I don't know...but my concept of radioactivity... I think it is some sort of energy... I can't explain.

.....

**AC:** I don't know, maybe like a kind of mist or fog, but you can see mist whereas radioactivity you can't. Maybe a kind of smoke... but you would be able to see it too.

**K:** Maybe a kind of dust. You can't see dust very well, even in the daylight.

**AC:** Maybe.

**AP:** No, maybe it really looks like electrical energy, because you can't see it by any means. You know there is energy because the lights are on, but you don't see it.

**AC:** Yes! I think you're right!"  
(MS2)

Unlike the majority of cases this discussion was pursued and followed-up by the group until, based on some differences in properties, they arrived at the conclusion that the analogy with electrical energy would probably be inadequate.

**\*AC:** But they've used lead so that it would not pass through... it would be insulated...

**I:** What do you mean by insulated?

**AC:** It won't let it pass... Lead is a very strong material.

**I:** Can you give me an example of another insulator or another thing that can be insulated?

**A:** Yes, rubber, it blocks electricity. It doesn't let it [electricity] get into your body. It stays in the rubber.

**I:** Would it [the insulation] happen in the same way in the case of radioactivity?

**A:** Well... hang on. Lead is an insulator for radioactivity, isn't it? But isn't it also a metal?

**I:** Yes.

**A:** But then... we have this concept that all metals are electricity conductors and I imagine radioactivity as a kind of electricity. But... in this case, how could it [lead, a metal] be an insulator for radioactivity? If radioactivity is a kind of electricity, how would lead, a conductor, be able to insulate anything? I think ...

**I:** ... that makes you think...

**A:** I don't know, maybe it's not a kind of electricity or ... is Caesium also a metal?

**I:** Yes.

**A:** ... maybe, because both are metals one "isolates" (neutralizes) the other, I don't know... I'm not sure... but it's not easy... maybe we cannot think of it as electricity, then... I would need to know more. (MS2)

This idea of insulation was quite common and was frequently mentioned in a context of discussing the need for special shielding. It was frequently developed and expanded so as to speculate about the nature of insulators and the nature of radioactive materials. In some cases it was not possible to identify whether the type of insulation or interaction perceived was electrical, magnetic or thermal, as in the quotation below.

**M:** But the lead... what is so special about it? I would like to know. It is a metal, isn't it? Why is it an insulator? Why does it prevent radiation to escape to the outside?

**I:** Any suggestions?

**J:** I don't know... Could it be because it is formed by the same kind of material... because in physics we learn that two bodies attract or repel each other depending on their components. Isn't it the case, it [lead] repels Caesium...

**I:** What do you think?

**J:** I think that lead may create a field that makes Caesium to join together, to hold together, instead of spreading, separating.

**I:** When you were talking about attraction and repulsion, which kind of interaction did you mean? I mean, would it be like an electrical...

**A:** No, I meant it [lead] has got a component to neutralise the radioactive material. (MS1)

As far as "analogues" are concerned, immaterial entities were, in general, preferred to material ones. The most often mentioned analogy was one with rays, especially with x-rays. In fact students evoked examples involving use, applications, effects or situations in which x-rays were likely to be present and discussed them as if radioactive materials were actually used in x-ray devices. In some extreme cases the taking of an x-ray is regarded as equivalent to radiotherapy and conclusions made in one case are seen as valid in the other. However, in most cases the confusion was avoided and some basis for the comparison was given. This illustrated by the quote below, in which students were talking about radiation/radioactivity.



*"P: I imagine it [radiation/radioactivity] like the ultra-violet sun-rays. It passes through but we cannot see it. Just like x-rays, we don't feel anything but it passes through our bodies...you cannot see them but they do affect you. You cannot see ultra-violet rays passing through the atmosphere or when you have an x-ray taken you don't see the particles passing through your body."  
(MS3)*

Radioactive materials' power to irradiate and the consequent need for shielding was also explained by analogy with the sun's infinite capacity to irradiate. In the words of one student:

*"A: It's like the sun, it's there, shining and it will never stop shining. Clouds come and go, there's the rain, but it's always there."  
(MS1)*

Some other interesting analogies made, though less frequently, were those which compared radiation to a kind of pollution, which resembles a dispersed "cloud" of particles that has hazardous effects on health.

(ii) Analogies of Processes:

It was common that a process which appears to be connected to radioactivity/radiation was explained by means of another process which happened to be more familiar in another context. For example, in order to explain the fact that you do not need to be close to a source to feel its effects, one student compared it to heat saying:

*" X: I think that heat... you asked for an example... well, I think heat is an example. Suppose there is a fire on that corner, on the other side of the room... It will warm up the whole room..." (NS3, p.3)*

*"Fa: It is [a kind of] heat.... If it is not heat, how can it cool the Earth down [as in the aftermath of a nuclear war]? ... And it produces heat too. (MS3)*

Another example, aims at explaining that radiation propagates as waves is:

*"Ve: ... it propagates like waves in a water tank. There is a drop and the wave propagates... reaching greater and greater distances... it's the same for radiation... further and further while its force lasts."  
(NS3)*

The way radiation/radioactivity can leak was described by some as similar to the way (kitchen) gas leaks. Again, in this case, there were very few cases where it

followed that a radioactive material was seen as a gas, and students appeared to appreciate the limits and the purpose of the comparison they were trying to make.

The process of contamination by a radioactive material was often described as similar to the process of contamination by a virus. In some cases this analogy appeared to hold further than simply an analogy of process. In the example below there is some indication that the analogy is developed so as to be able to speculate about some way of fighting against it in the body, perhaps with some sort of anti-bodies.

*J: It can be like a virus, you catch it and you contaminate other people...*

.....

*Fe: It is contagious. It provokes diseases, depending on how serious it is the person may even die, or become very ill...*

*I: Would it be possible to protect against it?*

*Fe: ... well... there is the de-contamination process... but that's different because then you are already contaminated. But ... for example... this thing of your own body to have means of fighting against radiation is still not very clear. Because... well, apparently cockroaches are immune to radiation, but nobody knows exactly how or why.*

*I: When you say the cockroach is immune to radiation, do you mean that it has means of fighting against it or that it is never affected by it?*

*Fe: I think that it is simply not affected.  
(MS3)*

This idea was developed and made more explicit when students questioned about the need for an external agent entering the human body and attacking anti-bodies.

*"M: I think it destroys the body's defences.*

*R: ... anti-bodies.*

*I: Could anti-bodies fight against radiation?*

*A: I don't think so.*

SILENCE

*F: I don't know... radiation would be like... .. small things entering your body and making you ill.... I can't imagine it like that ... though...*

*I: Is it...*

*F: If you are close to it...*

**A:** *I'll give you an example. If you're close to it... something like a fire or a furnace... something very big, if you come closer you feel hotter and hotter and that affects you more, it destroys the tissues. So, radiation is more or less like that.*

**R:** *That's a good example. If you stay close to it for a long time, you end up with that smell and you carry it with you... like a perfume, you don't need to pass it onto your body...*

**F:** *I don't know... I also think that there is an "incubation" period. In Chernobyl... no, I think it is Kiev, there were many people who were not in Chernobyl but in Kiev and they were affected. I don't remember very well... Anyway, people who were contaminated, even people who were away, they may not have it now, but they may have it in the future. The doctors don't know exactly, there will be an evolution of the disease, in 40 years ... it will appear. Like a virus that stays incubated, gets stronger and then explodes. (MS3)*

In the next case the student emphasises that she does not believe that radiation is like a virus. She states clearly that the process through which one person seems to be able to contaminate another is similar in both cases, but when it comes to comparing the nature of the contaminating agent the analogy does not hold anymore.

**A:** *... Just like a disease. There are some diseases that you don't know that you are ill. It is not until have you contaminated a lot of people that you realise [that you were ill].*

**I:** *Can you give me an example?*

**A:** *In a moment we will change the subject to viruses... (LAUGHS). A disease that contaminates ... let me see.*

**M:** *Well, my niece had meningitis and she didn't know...*

**Z:** *There's AIDS too.*

.....  
*(Students start discussing about AIDS and how to avoid contamination by the HIV virus)*

.....

**I:** *I am not sure whether I understand this comparison you suggested... the comparison with viruses...*

**A:** *No, it's not like a virus.*

**J:** *No, it's not a virus.*

**A:** *Not as a virus, but the way it acts, the way it behaves, the way the contact, the contagion occurs or appears to occur. (MS1)*

Other examples are:

*"A: It's different from the virus because it will contaminate even without entering the body." (MS1)*

*"AE: But there are microscopes... and you can see viruses in the microscope... you can't see radiation in the microscope. (MS4)*

One interesting description for the way emanations released by a radioactive material and, consequently, yielding some detail about the process through which contamination occurs, was in the form of an analogy with naphthalene. Nevertheless, changes of physical state were not mentioned in this context.

*"A: I think it is very similar to... very much like naphthalene. You don't need to touch it or even get too close to it to smell it. And you know, because it smells, that it is releasing [something]..."*

*CLA: Yes, I think it's the same case.*

*A: But naphthalene, when you take it out of the plastic wrap, it becomes smaller and smaller, so in these circumstances, I think that this material behaved in the same way: they opened the shielding, it started mixing with air and spread. (MS4)*

#### **8.5.1.2 Similarities of Effects equals to Similarity of Causes**

Some explanations students gave implied some degree of association between two given entities or events. This association was based upon a similarity of observable effects derived from the interaction between these entities or events with other entities and upon their known similar overt behaviour in other contexts.

This kind of explanation identified effects which were believed to arise from exposure to radiation, mainly physical symptoms of related diseases, and evoked other situations and circumstances when such symptoms were likely to occur. The next step was then to associate processes through which symptoms could appear. A very common example was to associate symptoms such as loss of hair, loss of immunities and certain types of cancer with both effects of exposure to radiation, with chemioteraphic treatment and with infection by the HIV virus. The next step is to associate the way the virus attacks the immunological system with the way radiation affects the human body internally.

It should be made clear that students appreciate that radiation and viruses do not possess the same nature and that the similarity perceived is one of process only. The point here is that this similarity at a more fundamental level is derived from an observed similarity at the surface, as in the example below, where a comparison between radiation and virus is put forward based on symptoms of related diseases caused by both.

*"A: It is like a disease. At the beginning you don't feel anything.*

*AE: Like a virus.*

*CLE: Like AIDS, because all those symptoms are caused by AIDS, it causes diarrhoea...*

*CLA: It destroys the anti-bodies... (MS4)*

Consider the fact that a person may be infected by a virus, without noticing it, and that there is an incubation period when the infection develops without any apparent symptoms of the actual illness. That was seen as similar to the fact that radioactive contamination may occur without being noticed and that it may take some time until the contaminated person presents the symptoms of consequent diseases.

### 8.5.1.3 Deriving Knowledge from Social Expectations

*"CLA: It's not that I have heard of [the existence] of many types of radiation. But there must be several types, of course there are several, otherwise they wouldn't bother to specify all of them, which one they are talking about, say, solar radiation, etc. " (MS4)*

*"A: And if you think about it, if it were so easy for it to propagate, the whole world should be contaminated because if it is her, it is spreading all over, from one city to the other, this unlimited propagation is impossible because, otherwise, everyone would be contaminated. (MS1)*

The quotes above illustrate instances where inferences are drawn and consequences are derived from a collection of facts which are familiar from other contexts and are thought to be generalisable enough to apply to the present situation. Justifications for the ideas are based upon the contraposition of the proposed explanation, which is intended to characterise a sensible expected course of action, with *any alternative*.

It is perhaps best exemplified when a student, to explain why a nuclear waste deposit has to be built with so much extra care, says that “they wouldn’t spend so much money” or that “they wouldn’t bother to make it so secure” if the possibility of contamination were not considerable. He is basing a conclusion about the nature of radioactive materials on a different kind of knowledge, in this case, previous knowledge of the attitude authorities may have in relation to expenses concerning public welfare.

Likewise, if x-rays (and similarly) ionising radiation were not dangerous and hazardous to health, why would radiologists be obliged to leave the room when x-rays are taken? It is interesting to notice that this fact is used so as to corroborate the notion of danger and hazard and not to exemplify measures of safety and control that should be employed when dealing with radioactive material.

This type of reasoning also appears to reinforce the view that contamination is necessarily contagious, as in the words of X:

*“X: Of course it is [contagious] ! Otherwise why had the victims to be isolated in special wards at the hospital? And why those masks and gloves and aprons all that?” (MS3)*

#### **8.5.1.4 Semi-Quantitative Reasoning**

Much of the reasoning employed by students could be identified as essentially qualitative. Very rarely did they make reference to possible ways of quantifying magnitudes which characterised the effects of exposure to radiation. Units were not mentioned by any of the groups either. Nonetheless there were several indications of the direction and magnitude of effects. That frequently happened in a form which was characterised by Ogborn (Ogborn, 1989) as *semi-quantitative*. This occurred when a description of the conditions under which radiation “acts” and its related effects was required. Time, distance, amount [of material] and dose were very often mentioned as factors upon which effects would depend. The “dose” of radiation received by people who were exposed was also frequently estimated in terms of these parameters. Typically students would relate effects as being either directly or inversely proportional to one or many of these factors. Some examples of this are:

*“R: The closer the person is , the more contaminated she gets. I mean, if the person is closer, the effect is bigger.” (NS3)*

*"A: ... and they had the stone with them for a long time before they knew anything about it. They were there everyday, sitting, eating, doing everything, with the stone right next to them, and it was so beautiful... it's time that matters, the amount of the contagion depends on the time you were exposed to it. (MS1)*

*"Fa: For the amount of Caesium was big and, because of that, it had more force, more power to act upon the environment. ... (MS3)*

#### **8.5.1.5 Knowledge of Properties Triggers Assumptions about Nature**

It was very common that some knowledge of the properties of, or of well-known facts about radioactive materials, triggered assumptions about their nature, as illustrated by the example below:

*"M: I have never seen Caesium, this radioactive material, I don't know ...but ... it must be powder-like so as to be able to spread all over... "* (MS1)

*"Ve: I think it is like a kind of rays .. I remember another story now! It's the story of an old man. I don't remember exactly where I heard this story of if I have read it somewhere... Anyway, it's about this old man who ran a bar. The bar had been built close to a few concrete boxes. So there was a wall, but the boxes were behind the counter where he worked for all day. After sometime, some blemishes appeared in his skin but he had not been burnt by anything. Then they discovered, some people discovered that, on the other side of the counter, behind the wall, they discovered that there was a radioactive material there, in the boxes. It was not Caesium, it was another radioactivity, but that was the reason for the burns on his back. It is the same with the burns caused by Cobalt in the medical treatments, the radiation, the rays reach you, you don't need to touch the material, the rays, the heat will get you and burn you." (NS3)*

In both cases something about the nature of the radioactive material is inferred from knowledge of some of its properties. Therefore, in order to spread all over, to reach distant places, to deposit over both flat and rough surfaces, it must be like tiny little particles as some kind of powder. Similarly, burns are something to be known as provoked by heat and there is no need to be close to the source to feel the effects of thermal radiation.

Another example is that of a girl, who believed radiation lasts forever, and the way she justified her opinion about radioactive material activity.

*"Ve: ... well, it [radioactive material] is not a living being, is it?"*

**I: What do you think?... Jullana?**

**J: I think that if it were alive it would die . (NS3)**

### 8.5.2 SUMMARY

The network in figure 8.2 summarises students' views on the nature of radioactivity/radiation/radioactive material. It also reflects the fact that, as many students said, most of the difficulties associated with the concepts concern its nature and not so much the processes through which it is perceived to act or behave. According to some students *knowing what it really is* is crucial for an understanding of its effects. In fact some students go further and say that "*if we knew what it is then we would know better the processes*", that is, seeing properties and process as determined primarily by the nature of entities. Evidence for that is the fact that, in many cases, the discussion of some processes, especially contamination, was inhibited because of the feeling some students had of not knowing enough about the nature of radiation.

Overall the general picture of the results is consistent with results already presented. It is indeed very similar to that provided by the results of the questionnaire study. It serves to reinforce the idea that there is a great deal of ambiguity and uncertainty, perhaps caused by their lack of relevant knowledge on the subject. Features like the materiality ambiguity, the clear-cut characterisation of activity and the hesitancy about ways of blocking or preventing its effects are undoubtedly present.

Most students would characterise the concepts as possibly either made of particles or as some kind of rays and which can move either by itself though reaching further targets if "carried". It acts on bodies around it mainly in a negative way and its power of propagation and contamination depends strongly on the amount of existing material. It is essentially non conserved and probably does not need a medium, as far as transportation in space is concerned.



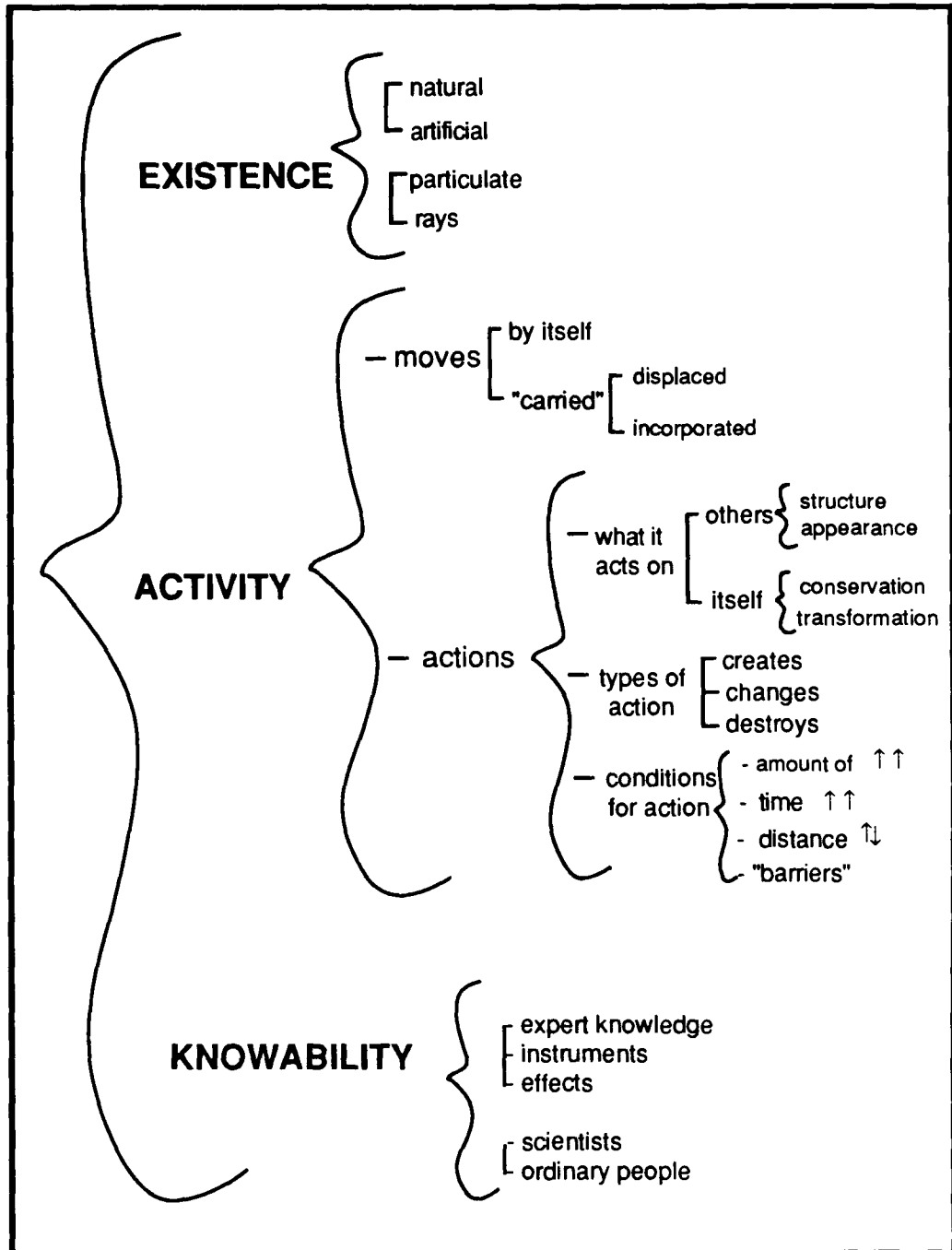

Figure 8.2: Network summarising students' views on radioactivity

In so far as types of reasoning which appear to lie behind students' explanations of radioactivity are concerned, it is possible to say that the need for thinking of it as something else is present in most of the explanations. Some kind of analogy or model, where the both the nature and the properties of the analogue or object on which radioactivity will be modelled are explored so as to test which of these features and properties hold. Some limitations of such comparisons can be appreciated by a few students.

A notable aspect of the thinking is the pragmatic aspect use of ordinary social knowledge. Quite deep inferences about the nature of radioactivity are made, using knowledge of what people usually do, or what can normally be expected in practical affairs. For example, if the dentist must leave the room, the X-rays probably cannot penetrate brick walls.

---

---

## CHAPTER IX

### STUDENTS THINKING ABOUT RADIOACTIVITY

---

---

#### 9.1 UNDERSTANDING

The second part of the interviews with groups required students to read a text containing information about radioactivity, comment upon their difficulties in making sense of the information it presents and summarise it by constructing a semantic network. The discussion of students' understandings will concern both observations about their difficulties in interpreting information contained by the text and remarks about how pre-conceptions may shape the understanding of new related information. The translated text is given in Chapter 5 and the original in Appendix 5.3.

In average, students took approximately 12 minutes to read the text, which was given to them at after the first part of the group discussion. They were asked to read the text individually and, later, to discuss their opinions about what its main message was and to represent this in the semantic network.

The text students were presented with contained information about the nature of radioactivity and its effects on matter. It begins with a description of radioactivity as a process which involves nuclear disintegration, energy release, formation of new atoms and emission of one or more types of radiation. It then presents comparisons between the power of penetration of different kinds of radiation and the potential damage caused by exposure to, inhalation and ingestion of radioactive material. Examples related to the accident at Goiânia are given to illustrate these points. This is done in three paragraphs, which end with information about Caesium 137 transforming into Barium 137 after emitting one particle. The text goes on with a discussion of the transformations it causes in matter. Ionisation is described as a

process in which electrons are removed having as an effect, changes in the characteristics of molecules which can be observed macroscopically. Such changes are also described for the case of interaction of radiation with living tissue. The consequences of exposure to radiation is either total destruction of or changes in the way cells reproduce. This explains why radiation is capable of both causing and help the treatment of cancer. Occurrence of cancer after exposure to radiation is described as a statistical probability. The last paragraph explains how radioactivity is measured and defines the Curie as the number of disintegrations of a given radioactive material per second. It also presents data about the activity of the teletherapy device involved at the accident of Goiânia.

### 9.1.1 HOW DO STUDENTS FIND THE TEXT?

Students' first reactions were that the text was not particularly helpful as providing explanations for their doubts. After having read it, their original questions and doubts remained for most of them, even for those whose first reaction had been to find the text well written and, in principle, understandable. For some students the text really missed the point and left out the most important bits of information one would need to know, while for others, the explanations given were not easy to grasp. For most students, the understanding of the text was dependent on two main factors, namely the level of interest of the reader and his educational background.

The quotation below exemplifies this point:

*AD : This thing of alpha, beta and gamma...*

*AP: I think this explanation is very superficial.*

*C : But it was written for people who don't know much about it.*

*AP: For this very reason ! People who read newspapers will not understand this.*

*AN: Say a bus collector.*

*I : What would you need to understand it ?*

*AD : Some interest. The person has got to be interested.*

*C : And apart from that...*

*AP : To know about particles.*

*C : It is difficult anyway. They cannot explain everything. There will be always certain things that a lay person won't know. (NS5)*

Criticisms about the text concentrated on two related issues, namely the language used and the audience to which the text was supposedly addressed. It was considered by many students as too "technical", containing a lot of statistics. In addition, knowledge of chemistry and mathematics was thought to be required for its comprehension.

**I: So... how do you find the text?**

SILENCE FOR NEARLY ONE MINUTE

**I: What were your Impressions...**

**A:** Well... I think I have learnt much more talking than reading this text because it's too technical, it has a lot of statistics and numbers... these numbers here at the end...I didn't understand this bit very well. I think that what really interests us is left behind.

**Z:** Well... and for someone who doesn't have information about it ... he will not understand it. I am not talking about illiterate people because an illiterate person cannot does not read the papers anyway. But ... somebody who is educated, who has done an undergraduate course, no... or even an ordinary person... do you know what I mean? Even this person will not understand it. ... For example, he talks about ionisation. How many people are there that know what ionisation is? If you stopped school at primary school, what are you going to make of it? Look, he says: " $1 \text{ Curie is equal to } 3.7 \times 10^{10}$ ", these are things that ...

**I: Do you think that this bit of information is unnecessary?**

**A, M and J:** No, no.

**M:** It's just not the most important.

**A and M:** Yes, it's necessary but it's not the most important.

**M:** The most important bit is that it modifies the atoms, when it passes through matter it modifies the atoms.

**A:** O.K., but for a person who has not studied physics or chemistry, a lay person, because this [the text] comes from a newspaper, doesn't it? So, there are some parts here, for example this thing of  $3.7 \times 10^{10}$  to the ... it interests us because we are at school and we know what it is. But a lay person, who doesn't know anything about it, will simply skip it.

**I: What do you think is the most important bit of information that you need?**

**A:** How it propagates, what it is, what can we do in case of contamination, these kinds of thing. How will it get you? How does it affect you? The ways it contaminates, what can you do to stop it...

**J:** But it does say here: paper, aluminium, lead, ...

**A:** *Yes, but it doesn't say in detail. It says here that if you put a sheet of paper you'll stop an alpha particle, if you use aluminium you'll stop a beta particle. But, what's an alpha particle? What's a beta particle? What's the difference between them?*

**J:** *Yes, that's right... it doesn't say in detail. (MS1)*

The issues of the audience to which this kind of information should be addressed and the language used to communicate such ideas are linked together by one student when she says:

**A:** *...What is a Curie? ... it says here it is equal to 3.7 disintegrations per second... What is that? I know that... but somebody who lives in the shanty towns... I know that because I have studied these numbers in Maths. I may live in the "shanty towns", but I go to school, I know what it is. But my father, my aunt, my grandmother, they have never studied that. And they are the ones, because of their poor education and their lack of knowledge, that will be affected by it.*

**M:** *In general... it happens with people who doesn't know anything about it.*

**A:** *Because the man who found it, the owner of the junk-yard, if he had been educated he would stop and think -- 'where does this thing come from? From a clinic. Right. It was sealed with lead. It must be dangerous. I'd better not to touch it'. No... the exact opposite happens... he doesn't realise the dangers and opens it and finds it beautiful and gives it away to everyone he knows...*

**M:** *And also because he wanted money for the lead... (MS1)*

The nature of decay was clearly problematic for some students who appeared to have difficulties with this notion. That might have been reinforced by the way numerical information is presented in the text. Although the text did not present a qualitative explanation the mere reference to rates of decay and simple proportion calculations were enough to provoke a negative reaction in some students. The quotation below exemplifies this.

**E:** *... the worst bit is this bit of disintegration. In 1971, when it was fabricated, there were 2,000... 74 million of atoms... now... when the accident happened, it was worth 1,270 ... I don't understand these calculations... In 1971 it was equivalent to that, and that is 2,000 Curies...*

**S:** *Yes, these are numbers that were put here to make it easier to understand, but they are not simple to understand at all. (NS2)*

In fact, what a Curie represents, remained obscure for most students, even after reading the text. It was not understood properly as a unit of measurement and the closest they could get to understanding its meaning is exemplified below. This

quotation may also suggest that, perhaps for some students, a meaningful unit is that which, perhaps, gives some indication of the power of a radioactive material, maybe in terms of its effects (on matter) .

**R:** *I really didn't understand what a Curie is...*

**V:** *Curie is a measurement of the ... they've used it to... to explain... to determine the force of Caesium or of the radiation...*

**R:** *No... but, what's its consequence? I mean what is its power? For example... 1 Curie... what is its power?*

**I:** *What do you mean by that?*

**R:** *I mean... is it a lot... is it a little... what is it? We need more specific information here. (NS3)*

This linked with a discussion about conservation. For some students it was not clear whether the actual number of atoms had decreased or whether the "power" of the radioactive source had decreased. A few students suggested a possible comparison with energy in order to understand better the nature of the decay. They would associate the radiotherapy device to a non-renewable source of energy like, for example, a battery, and associate this "decrease" to energy that is used up. The quotation below makes reference to this point.

**A:** *... if you've got a battery at home, it releases energy, it is used up, it hasn't got a way of getting more energy... to replace energy.*

.....

**Se:** *Hang on! Maybe the proportions are not correct here. Is it correct to compare a battery to a Caesium bomb?*

**E:** *Well... that's not the point really, is it? The important thing is that it is releasing energy and that this energy has to finish.*

**Se:** *And, according to what you're saying, the fact that it was opened made it... to finish... to decrease quicker...*

**A:** *That's right.... [It had a greater power] because it was sealed. Of course, it had been used up at the hospital.*

...

**A:** *I think it's the same as if you picked up a light-bulb and put it inside a black box with only a very small hole. Then you could control whether you wanted more or less light.*

**E:** *Yes, that should be right. It was releasing all the time but it was controlled, otherwise everybody who worked at the hospital would have been contaminated too. (NS2)*

**A:** ... when it's fabricated it has a very strong force, but then it decreases and... but it takes very long to finish... I think maybe it never finishes, there's always something left... some of it is left... maybe it is very little, sometimes it turns into another element but there's always some of it... some of it is left even after many years.  
(NS6)

On the other hand, the text was considered as containing lots of "new important" information about radioactivity, such as the existence of different types of radiation, how ionising radiation is used in Medicine and the definition of half-life. The way it affects the human body was also considered "well explained" and was carefully read by most students to whom it was a main concern.

Nevertheless when asked which was the main message of the text, nearly all students' responses contained some reference to the dangers associated with radioactivity and its applications. Some typical responses were "to inform the population of the dangers that Caesium represents to mankind" (NS2). However, some attenuated comments like, "to warn people that Caesium is an element that can help as well as be harmful to people" (NS4) were also made, though less frequently. This is consistent with the fact that danger was the most significant and prevalent feature in students' responses to questions related to properties attributed to the concepts of radiation, radioactivity and radioactive material (see chapter 7, section 7.4.2).

The credibility of the information conveyed in the text was raised as an issue for discussion by some students. Most of them thought that the information "must" be true, for two main reasons. One was that it came from an interview with a specialist and the other was that it would not have been accepted for publishing if it was not true or reliable. However, a point made by a few students was that, be it true or false, they, as lay people, would not have any other alternative but to believe in it as they had no means to either question the facts or verify the results presented. The quotation below illustrates this point.

**AE:** I think the text is O.K.. It's well explained and so on. But if it wasn't... I mean... there is no way to know. There's no way I can tell. I would have to calculate if I want to know... if I want to be sure... I would have to have the equipment to detect... and that's not possible for an ordinary person." (NS4)



This suggests that some people feel, in a sense, alienated from this kind of knowledge. In fact this raises the issue of how much or which kind of knowledge one should have in order to analyse information critically. It is often argued that, owing to their lack of knowledge, people ultimately rely on the opinion of experts. Although this may be the case for most people, a problem arises when two experts hold opposing views on the same subject and people have to analyse the two lines of argument and decide in favour of one. In that situation, the question arises of how much knowledge, or which kind of knowledge one would need to be able to follow an informed debate. Some students' opinions converge to a view where both information and knowledge required by people are, in general, dependent on the relevance they might have for the lay person in daily life situations. This is exemplified by the quotation shown next.

*E: There's also this formulae here: three point seven times ten to the tenth power...*

*A: But this is not so important in the daily life. The important thing is to know whether or not it is dangerous. You don't have to make calculations to know that.*

*Se: But if there were no calculations... people need the calculations to know it is dangerous.*

*A: I know. But what really interests people is whether or not it is dangerous, people don't need to do calculations, people just can't do it. Can you imagine if everybody had to make some sort of calculation to decide whether it is dangerous or not? (NS2)*

## 9.1.2 WHAT DO THE NETS SAY?

### 9.1.2.1 Task administration

Semantic networks were used here with two main objectives. Firstly as a way of exploring how students would organise and structure the information contained in the text. Secondly as a 'motivation' for a complementary discussion about their understandings of radioactivity. Underlying these two objectives is a primary concern with the kind of thinking involved in making use of previous knowledge in order to make sense of new related information.

Following the group discussion about the text, students were asked to make a summary of what they considered to be the main ideas contained in the text, by

means of constructing a semantic network. They were presented with twenty-six cards corresponding to a list of entities, processes, objects, etc, covering most of the concepts mentioned in the text, which were to be used as the nodes in the network.

Similarly, there were eleven cards representing the labelled directed relationships which should be used to link nodes in the diagram. Links could be the classic class/subset links (is a kind of, is an example of, etc) or activity links, denoting the effects nodes could have upon one another (creates, destroys, etc). Links could also denote a more indirect influence of one concept upon the other (prevent or allow). By contrast to links, which could be used as often as necessary, nodes could not be repeated.

Students were allowed to consult the text whenever they judged necessary and were encouraged to discuss and justify their propositions. Instructions given also emphasised the need for an agreement on what should be represented in the net. No time was set in advance to complete the task. The average time spent by the groups was 30 minutes. The discussion which accompanied the mounting of the net was tape-recorded and transcribed, to clarify the meaning of links and associations. A list of all nodes and links is as follows:

<b>NODES</b>	<b>LINKS</b>
Radioactivity	is an example of
Nuclei	is a kind of
Atoms	is an amount of
Energy	is a part of
Radiation	creates
Rays	causes
Particles	provokes
Paper	produces
Person	destroys
Aluminium	prevents
Caesium 137	allows
Lead	
Barium 137	
Electrons	
Cells	
Cancer	
Time	
Probability	
Radium	
Disintegration	
Emission	
Penetration	
Substance	
Transformation	
Ionisation	
Curies	

Table 9.1: Nodes and Links allowed in the Semantic Network

### 9.1.2.2 Overview and Discussion of Results

The table below shows the number of nodes and links used in each net. Totals and breakdowns for school are given. The figures in the table reveal that, on average, nets were constructed using 14 of the twenty six nodes provided connected by 15 links. This is the case for both morning and night shift schools. In fact, as will be seen later there were no major differences among the nets constructed by students from the two school groups.

	NODES	LINKS		
		Class/Subset	Activity	Total
MS1	14	2	15	17
MS2	14	7	9	13
MS3	17	3	14	17
MS4	16	6	12	18
MS5	13	4	9	13
MS6	20	4	17	21
MS7	12	4	9	13
NS1	16	6	11	17
NS2	15	3	10	13
NS3	13	3	11	14
NS4	17	5	14	19
NS5	14	4	10	14
NS6	8	2	4	6

Table 9.2: Numbers of nodes and links per net

The fact that nets were constructed using only half of the links provided suggests that students were quite selective in relation to the information they decided to include in their summaries. Table 9.3 contains information about frequency of use of each proposed node and link. It shows that the nodes radiation, lead and cancer were used in all nets. In fact, a closer examination of the nets reveals that references to *radiation / radioactivity / radioactive materials as able to cause cancer* and to *lead as capable of preventing them* are present in all the nets. Links such as cause, produces and provokes were used to express this idea. In the case of lead being capable of 'preventing' radiation / radioactivity / radioactive materials, the link 'prevents' meant essentially 'prevent propagation' or 'blocks'. Other nodes used in most nets were energy, rays, particles, cells, transformation, Caesium 137, Barium 137. They were either connected among one another by links like 'is a kind of' (e.g. Caesium 137 - produces -> Barium 137) or by activity links such as 'destroys', 'provokes' or 'produces' (for example in Radiation (- is a kind of ->) Energy - destroys-> Cells, NS1; Radioactivity - produces -> Particles, NS3).

STUDENTS THINKING ABOUT RADIOACTIVITY

The table also shows that nodes such as Nuclei, Electrons, Probability and Radium as well as the link 'is a part of' were hardly ever used. It also shows that processes such as, Emission, Penetration and Ionisation, were mentioned less often than were physical entities.

<b>NODES</b>	<b>MS</b>	<b>NS</b>	<b>Total</b>	<b>LINKS</b>	<b>MS</b>	<b>NS</b>	<b>Total</b>
Radioactivity	5	5	10	is an example of	7	2	9
Nuclei	0	0	0	is a kind of	13	14	27
Atoms	4	3	7	is an amount of	6	7	13
Energy	6	6	12	is a part of	0	0	0
Radiation	7	6	13	creates	6	4	10
Rays	7	4	11	causes	12	9	21
Particles	6	6	12	provokes	12	7	19
Paper	2	2	4	produces	11	14	25
Person	3	3	6	destroys	13	13	26
Aluminium	2	2	4	prevents	10	11	21
Caesium 137	6	5	11	allows	6	1	7
Lead	7	6	13				
Barium 137	6	4	10				
Electrons	1	1	2				
Cells	5	6	11				
Cancer	7	6	13				
Time	3	1	4				
Probability	0	1	1				
Radium	1	0	1				
Disintegration	5	3	8				
Emission	5	0	5				
Penetration	2	3	5				
Substance	4	2	6				
Transformation	6	4	10				
Ionisation	3	2	5				
Curies	3	3	6				

Table 9.3: Frequencies of use of nodes and links in the semantic networks

The table also shows that 'activity' links were used much more often than class/subset links. 'Destroys', 'produces', 'causes' were often associated with negative effects of radiation, radioactivity and radioactive materials, and 'prevent' was used in connection with the idea of lead shielding. 'Is an amount of' was used nearly just to express the relationship between Radioactivity and the Curie. 'Is an example of' was regarded by students as giving an indication of strong similarity and, for this reason, was avoided many times, with 'is a kind of', to which a vaguer connotation was attributed, being preferred instead.

'Allow' was used to refer to an action which although necessary was not sufficient to cause a given effect. One example is Time - allows -> Ionisation (MS4). In general links are used to indicate 'negative actions'. Examples of these are:

Radiation - provokes -> Cancer (MS1), Radioactivity - causes -> Cancer (MS3) ,  
 Radioactivity - destroys -> Cells (MS2), Caesium 137 - destroys -> Person (MS1).

An overall view suggests that, most nets, despite their diagrammatic arrangement, consist of linear 'chains' of nodes, with interconnections being, in fact, rare. This is illustrated by the contrast between figures 9.1 and 9.2.

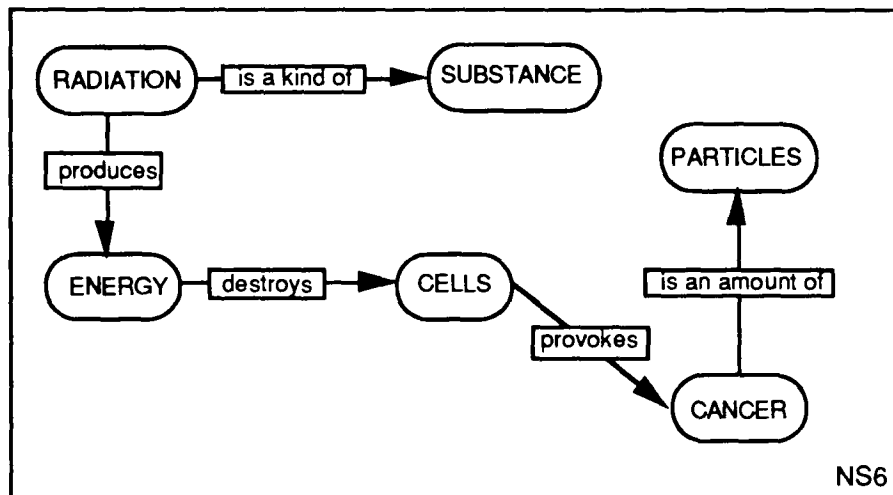

Figure 9.1: A linear 'chain' of nodes

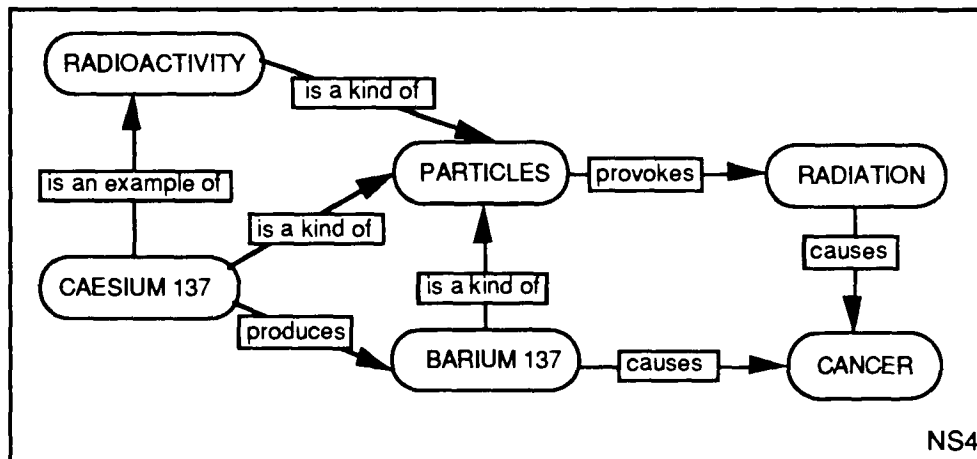

Figure 9.2: Interconnected nodes in a network

One indication of how structured a net is, is the ratio between of the number of links to the number of nodes. It is easy to see that the maximum ratio between links and nodes in a net which has  $n$  nodes (where each node is connected to one another) is  $(n-1)/2$ . The table below compares these numbers with the actual ratios, as calculated for each net.

	$\left(\frac{\text{links}}{\text{nodes}}\right)_{\text{m}\acute{\text{a}}\text{x}}$	$\frac{\text{links}}{\text{nodes}}$
MS1	6.5	1.2
MS2	6.5	1.1
MS3	8.0	1.0
MS4	7.5	1.1
MS5	6.0	1.0
MS6	9.5	1.1
MS7	5.5	1.1
NS1	7.5	1.1
NS2	7.0	0.9
NS3	6.0	1.1
NS4	8.0	1.1
NS5	6.5	1.0
NS6	3.5	1.3

Table 9.4: A measurement of net structure

This table also repeats, indirectly, the information about how many nodes were used to construct each net. On average, each net contained fourteen nodes. The ratio between links and nodes is in most cases slightly greater than one indicating that the number of links is approximately the same of that of nodes. This is consistent with the general view that diagrams set out by students were mainly chains of nodes.

A more sensitive measure of how structured a net is obtained by dividing the total number of links associated to each node (either “departing” from or “arriving” at each), by the total number of nodes. These figures, shown in Table 9.5, represent better the degree to which a net presents more or less connections. For example, in the case of nets NS4 and NS6, whereas the ratios of links to nodes differ by just 0.2, the ratio between the total of all links associated to each node to the total number of nodes differ by 0.9. In fact this quotient reveals differences which would not be noticed just by inspecting table 9.5, such as that between NS1 and MS6.

	<b>all links/nodes</b>
MS1	2.3
MS2	2.2
MS3	1.6
MS4	2.2
MS5	1.7
MS6	2.3
MS7	2.2
NS1	1.9
NS2	1.5
NS3	2.2
NS4	2.2
NS5	2.0
NS6	1.3

Table 9.5: Another measurement of network structure.

As further way looking at the nets, the computer language PROLOG was used to answer the question, " Given a net, how many inferences can be made from it ?". For example, given:

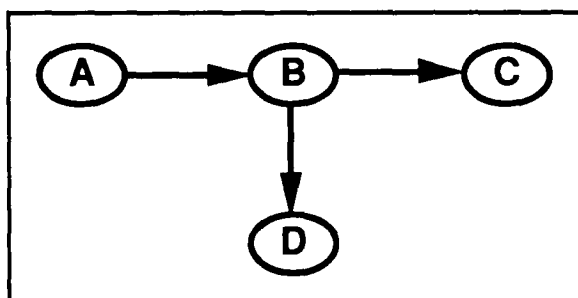

Figure 9.3: Scheme of an arbitrary net

If arrows are causes, it is possible to infer, besides  $A \rightarrow B$ ,  $B \rightarrow C$ ,  $B \rightarrow D$ , the more indirect inferences  $A \rightarrow C$  and  $A \rightarrow D$ . The same can be done for indirect inferences with 'is a' relationships.

PROLOG is a programming language adapted to logical inferences (Bratko, 1990). Each pair of two entities and a link from a semantic network are expressed in PROLOG as rules with the following general form:  $\text{LINK}(\text{ENTITY 1}, \text{ENTITY 2})$ . For instance, in the net of MS2 (shown in figure 9.4), the program is as follows:

## PROLOG programme for MS2 Net

```

prevents(lead, radioactivity).
prevents(lead, caesium).
destroys(radioactivity, cells).
destroys(ionisation, cells).
produces(caesium, barium).
provokes(radioactivity, ionisation).
allows(atoms, cancer).
is_kind_of(caesium, substance).
is_kind_of(barium, radiation).
is_kind_of(radiation, energy).
is_kind_of(radiation, rays).
is_kind_of(radiation, particles).
is_kind_of(radiation, atoms).
is_example_of(ionisation, transformation).

```

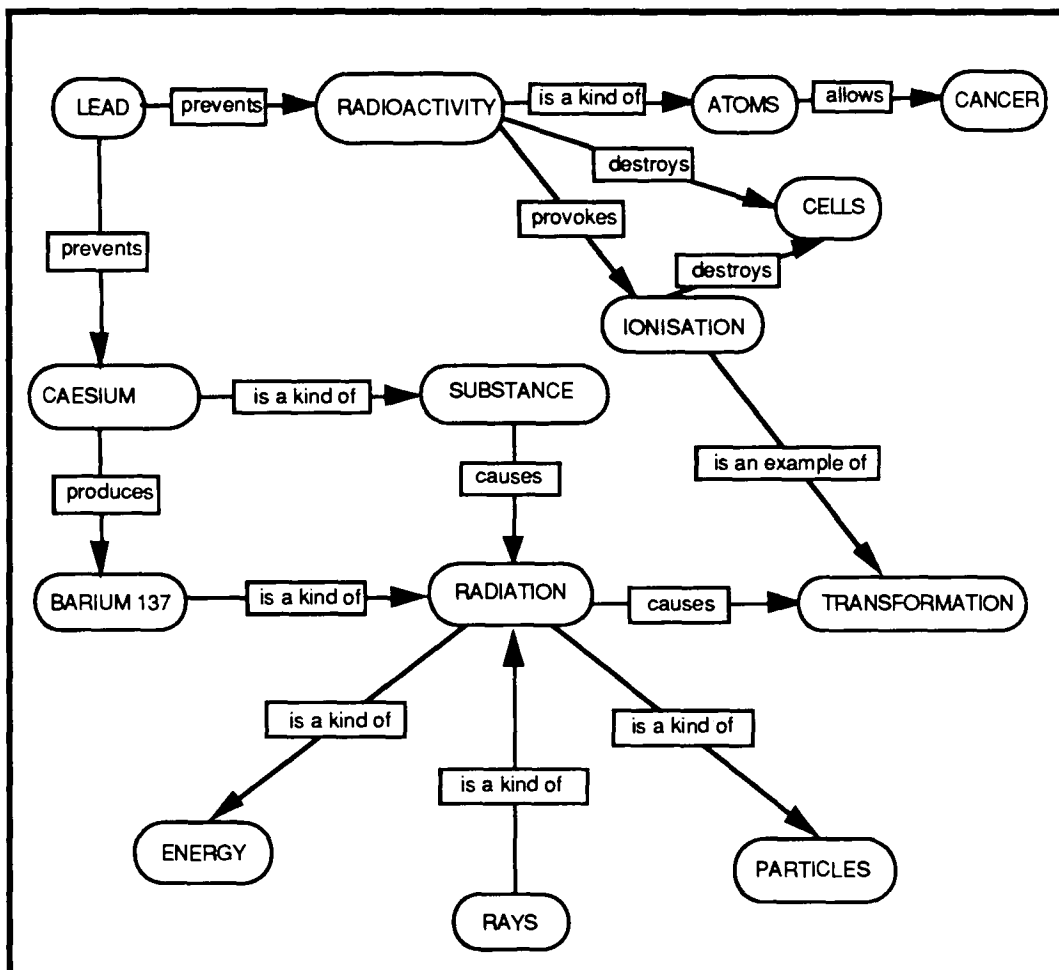

Figure 9.4: Semantic Network MS2

There are other facts, which, although not explicitly represented in the nets and therefore not stated as clauses in the programs, can be inferred from this net. For



instance, from the following facts: (Lead - prevents -> Radioactivity) and (Radioactivity - provokes -> Ionisation), is possible to infer that (Lead - prevents -> Ionisation). Likewise, things which are seen as kinds of radiation, such as, for example, energy, rays and particles, can also be inferred to cause transformation, as radiation causes transformation<sup>1</sup>.

Meta-rules were added to define sequences of links. An 'is a' chain was defined as any chain if 'is a' links. An 'activity chain' was defined as any chain containing causal links only, which could be of several kinds. A 'causal chain' was defined as any chain consisting of 'is a' links or causal links, but with at least one causal link.

A PROLOG programme works by answering queries. In the analysis, queries could ask how many links or chains there were of a given kind, or what they were,; what links or chains led from or to a given node, or whether two given nodes were connected, directly or indirectly.

Questions about numbers of links or chains allow some comparability among the nets, giving an indication of the nature of the relationships between the entities chosen. Other questions allow the identification of particular relationships which may be of interest. For example one may want to know to what extent the concepts of radiation, radioactivity and radioactive material are seen as differentiated or not. A typical query aiming at listing all the case where some kind of class/subset relationship is obtained is :

Q: is\_link(X,Y)  
A: X,Y

In the case of MS2 net, the answers are:

radioactivity,atoms  
barium,radiation  
caesium,substance  
radiation,energy  
rays,radiation  
radiation,particles  
ionisation,transformation  
barium,energy  
barium,particles

---

<sup>1</sup>This is actually a statement of the "inheritance" property of the semantic network (see chapter 5).

The program works by searching for 'is a' links, as they were defined, and prints the cases which match the query, displaying the node at the beginning of the link (head) and the node at the end of the link (tail).

In this example, the nature of all is\_a links indicate, once more, the confusion between the concepts of radioactivity, radiation and radioactive material ( as exemplified by Caesium And Barium). It is possible to check whether this is a feature that appears in all nets by checking directly what the associations of the is\_a type are for each of the concepts. This convenience makes easier the identification of well known misconceptions and also facilitates the spotting of certain association. For example, in the case of radioactivity, this query would be:

Q: is\_link(radioactivity,Y)

A: Y

It is also possible to search for causal chains with the following query:

Q: cause\_chain(X,Y)

A: X,Y

For MS2, the answers are:

caesium,barium  
radioactivity,ionisation  
substance,radiation  
radiation,transformation  
ionisation,cells  
radioactivity,cells  
lead,radioactivity  
lead,caesium  
atoms,cancer  
radioactivity,cancer  
barium,transformation  
caesium,radiation  
caesium,radiation  
caesium,energy  
caesium ,particles  
caesium,energy  
caesium ,particles  
radioactivity,transformation  
substance,energy  
substance,particles  
lead,atoms  
lead,substance  
caesium,transformation  
radioactivity,cells  
substance,transformation  
lead,ionisation

lead,cells  
lead,cancer,  
lead,transformation  
lead,cells  
lead,cancer  
lead,transformation  
lead,cells  
lead barium,  
lead,radiation -  
lead,radiation  
lead,energy  
lead,particles  
lead,energy  
lead,particles  
lead,transformation

Repeated pairs indicate that different paths were found linking them.

Combining these results with an inspection of the net, it is possible to see that out of the 44 causal associations allowed by the net, 9 involved the association of two nodes, 16 involve three nodes, 13 involve four nodes and 3 involve five nodes. They all have the form of 'chains of activity'. For instance, Lead --prevents --> Caesium -- produces --> Barium -- is a kind of --> Radiation -- causes--> Transformation.

Some chains include both causal and 'is a' links, giving an indirect causal relation. Consider, for example, the case of the association between Rays and Transformation. The program takes into consideration the relationship Radiation -- is a kind of --> Rays and infer that a ray, as being a kind of radiation, which is associated to transformation, must be associated (may be causing) transformation too. In this net there are three cases of these more indirect inferences, namely that between Lead and Cancer and that between Lead and Radiation. As the nature of associations of this kind have to be guessed, they will not be discussed in this analysis.

A similar analysis was done for all the nets and table 9.6 summarises information concerning the number and the kinds of inferences allowed by each of the nets.

STUDENTS THINKING ABOUT RADIOACTIVITY

NETS	Inferences			Is_a	Amount_of	Causal				
	Direct	Indirect	Total			Direct	Indirect	Activity	Mixed	Total
MS1	17	15	32	2	0	15	15	21	9	30
MS2	16	33	49	9	0	9	31	24	16	40
MS3	17	16	33	0	3	14	16	30	0	30
MS4	18	22	40	5	2	12	21	26	7	33
MS5	13	8	21	3	1	9	8	15	2	17
MS6	19	31	50	0	3	16	31	47	0	47
MS7	13	5	18	4	0	9	5	12	2	14
NS1	16	24	40	4	2	10	24	13	21	34
NS2	13	25	38	2	1	10	25	15	20	35
NS3	13	14	27	3	1	10	13	20	3	23
NS4	18	35	53	6	1	13	33	28	18	46
NS5	14	30	44	4	1	10	29	26	13	39
NS6	6	3	9	1	1	4	3	7	0	7

Table 9.6: Number and types of inferences allowed by semantic networks.

From table 9.6 it is possible to see that there seems to be little difference between the two groups of results of schools, in so far as the number of inferences allowed by the nets is concerned. Most of the links are causal and the majority of the causal associations correspond to causal chains which link at least three nodes. The only exception are nets MS7 and NS6 which do not allow as many inferences as the others.

Examples of parts of networks containing long chains of activity, or causal chains, are shown in figures 9.5 and 9.6. In most cases they include both positive and negative links. From an analysis of such causal links, it is possible to see that Radiation, Radioactivity, Caesium, Barium and Energy are seen as essentially active concepts, having in most cases more arrows either departing from or arriving to them than processes such as Ionisation, Penetration and Transformation have. Processes were not connected to many nodes either, with the possible exception of Disintegration which was more frequently associated to Atoms, Particles or to radioactive materials. One reason for this may be the stronger emphasis given to this process in the text. Cells, Particles, Substance, Atoms and Time are, on the other hand, examples of concepts which were not connected to as many nodes as those mentioned above.

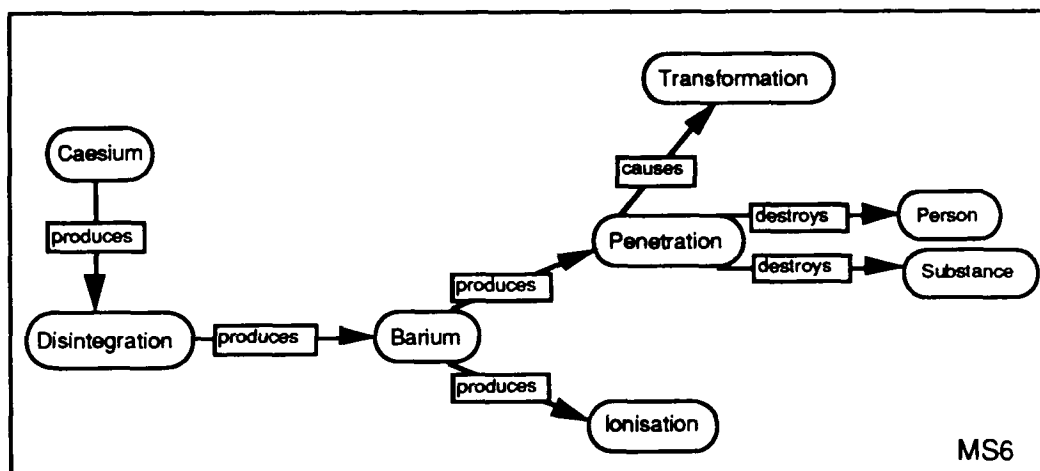

Figure 9.5: Example of part of a network containing long chains of activity (I).

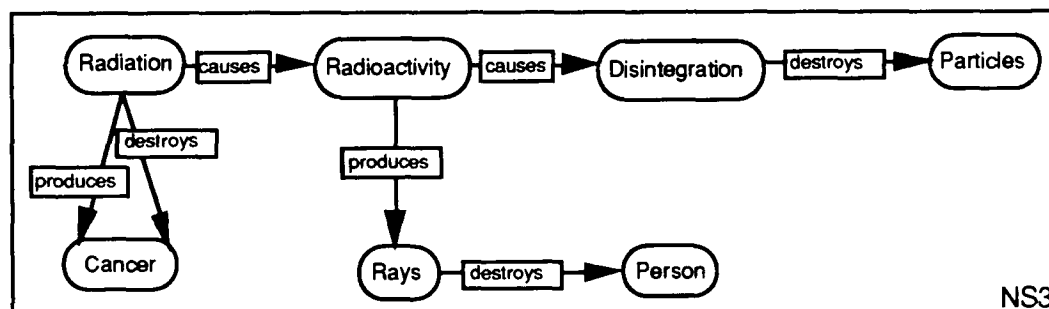

Figure 9.6: Example of part of a network containing long chains of activity (II).

Finally, instances of the confusion between substance and activity as observed earlier in media reports (see chapter 4) as well as in students' responses to the questionnaire and interviews (see chapters 7 and 8), were also observed in the networks. One example is from net NS4. The association Curies -- is an amount of --> Barium, together with Barium -- is a kind of --> Particles, leads to Curies being associated with Particles.

### 9.1.2.3 The Nets as Summaries of the Text

Since the networks were constructed by students with the objective of summarising the text, it is interesting to examine how far the information contained in the nets relates to the information contained in the text. An analysis of the nets in relation to the text will involve then looking for:

STUDENTS THINKING ABOUT RADIOACTIVITY

- What is *in the text* and *in the net* ?  
 What is *in the text* and *not in the net* ?  
 What is *in the net* and *not in the text* ?

Table 9.7 shows which items of information were present in the text only, in the nets only or in both. The types of information listed in the first column correspond to the researcher's interpretation of the main ideas contained in each paragraph of the text and of some associations made by students.

	MENTIONED IN THE TEXT	TEXT NOT NET	TEXT AND NET	NET NOT TEXT
RY - disintegration - forms other atoms	✓	✓		
RN as emission of particles / rays	✓		✓	
Different power of penetration of $\alpha, \beta, \gamma$ particles	✓		✓	
Caesium 137 transforms into Barium 137	✓		✓	
Ionisation - changes in characteristics of molecules which constitute atoms	✓		✓	
Ionisation - changes in living tissue	✓		✓	
Radiation both helps treatment and increases chances of getting cancer	✓		✓	
Possibility of developing cancer is statistical probability	✓	✓		
Radioactivity is measured in Curies	✓		✓	
Activity decreases with time	✓	✓		
Relationships between RY, RN and RM				✓
Type relationships between atomic particles and radiations / Nature of radioactive elements				✓
Effects of cancer on people				✓

Table 9.7: The Nets as Summaries of the Text

It is possible to see that students rarely included information which was not in the text in the nets. In fact, in most groups, students tried to be as complete as possible, including all information available in the text that they could and avoiding interpretations of their own. One type of extra information they did mention was that about the type relationship between radioactive materials and atomic particles. When they did include information of this type, it was regarded by them as additional information that could be omitted without spoiling the meaning of the activity link. This is illustrated by figures 9.7, 9.8 and 9.9, where such extra information is shown in bold.

STUDENTS THINKING ABOUT RADIOACTIVITY

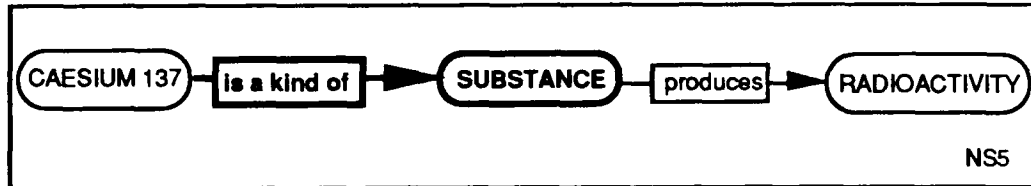

Figure 9.7: Information that was in the nets but not in the text (I).

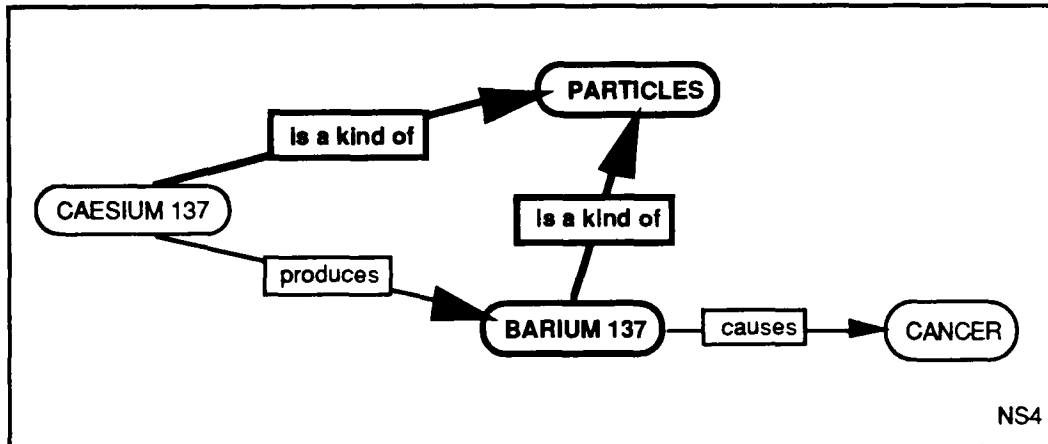

Figure 9.8: Information that was in the nets but not in the text (II).

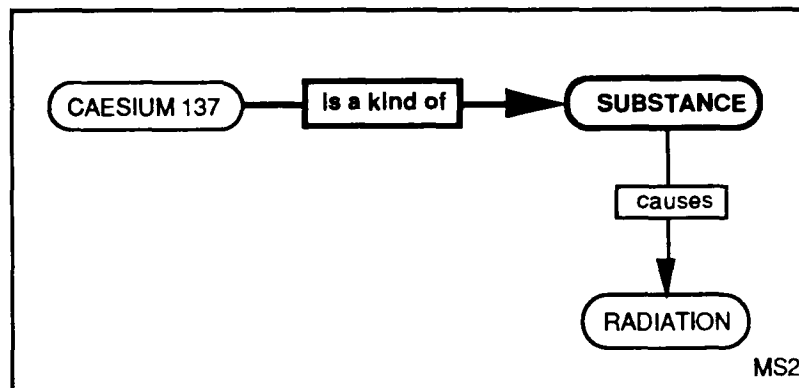

Figure 9.9: Information that was in the nets but not in the text (III).

The other type of information that students included in their nets, that was not explicitly mentioned in the text, related to their own knowledge about the effects of cancer on people. About half of the nets included information about people being 'destroyed' both directly and indirectly, by radiation, cancer or radioactive materials. In this case, the link 'destroys' was used as meaning 'kills'.

Despite not being overtly discussed in the text, relationships between the concepts of radiation, radioactivity and radioactive material were made explicit by all but one group. Links attached to these concepts were both class/subset and activity links. A

closer analysis of the class/subset links used reveals more about possible differentiations between them.

Radioactive materials were more often associated with particles, atoms and substance, though there were a few cases of links with rays and radiation too. Radioactivity was also associated with particles, atoms, radioactive materials and substance, but more often with radiation, energy and rays. Only once was it associated with a process, namely that of emission. Radiation was equally associated with particles, substance, atoms and radioactive materials, and with rays, radioactivity and energy.

Direct associations made between radiation and radioactivity were not as many as one might expect in view of the strong pattern of undifferentiation between these two concepts as suggested by the questionnaire study results (see Chapter 7, section 7.5). Although the text does not contain an explicit discussion about the nature of these concepts, many students noticed that the words were used in two different contexts. That was revealed by hesitation in employing the two words synonymously during the discussion of the net. That does not mean students were able to differentiate the concepts at all. In fact, the confusion between the concepts became hidden. The two examples shown in figures 9.10 and 9.11 are used to illustrate the points above.

In these nets, Caesium 137 is seen as able to create/produce/provoke both radiation and radioactivity. Radiation is also seen as a kind of energy and as able to provoke/cause cancer by both groups. Similarly, the information that radioactivity is measured in Curies was translated as 'Radioactivity <-- is an amount of --> Curies' by the two groups. It is also the case that in the two examples Radiation has more links attached to it, whilst Radioactivity is only associated to Curies. In the net shown in figure 9.11 it is Radioactivity (and not Radiation) which is seen as a kind of emission, denoting some confusion between the two concepts. For this reason, it is not possible to understand the different associations made with the concepts as an indication that students perceive a distinction between the two. In fact, that might be only related to an attempt to be faithful to the text.



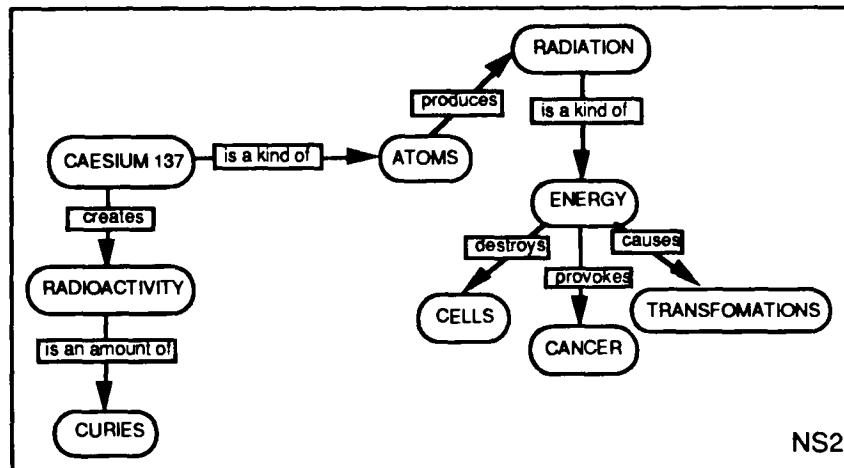

Figure 9.10: Nature of relationships between radiation, radioactivity and radioactive material (I)

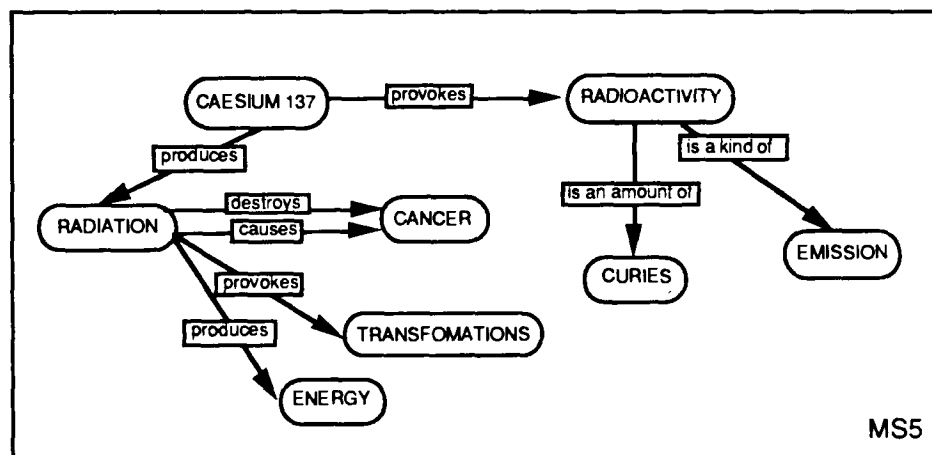

Figure 9.11: Nature of relationships between radiation, radioactivity and radioactive material (II)

All three concepts are seen as essentially active, in that the number of activity links which are associated to each of them usually outnumbers those of class/subset type. It was also possible to find in most nets 'chains of activity', that is, nodes connected by activity links only. Many of them emphasised the destructive character of radiation/radioactivity/radioactive material on matter.

Information which was both contained in the text and which appeared frequently in the nets related mainly to the effects of ionising radiation on living tissue. This links with the strong interest in knowing more about "how radiation affects both living and non-living things" as identified in the quantitative study (see chapter 6 and chapter 7). It relates also to the fact that most of the students considered the main message of the text to be "a warning of the possible dangers of radioactivity to mankind" as reported in the last section. Examples of that are shown below in figures 9.12 and 9.13.

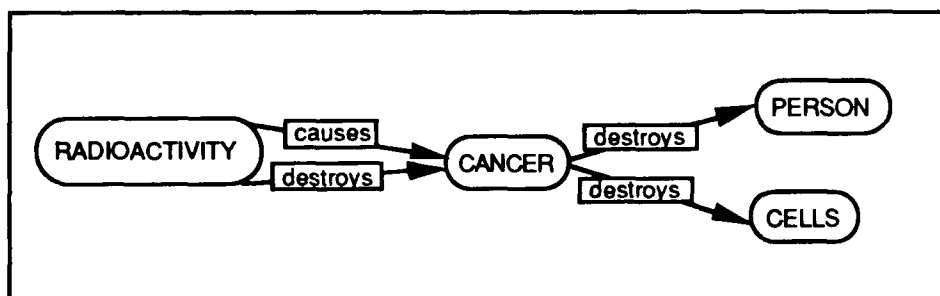

Figure 9.12: How radiation affects living tissue I (NS5)

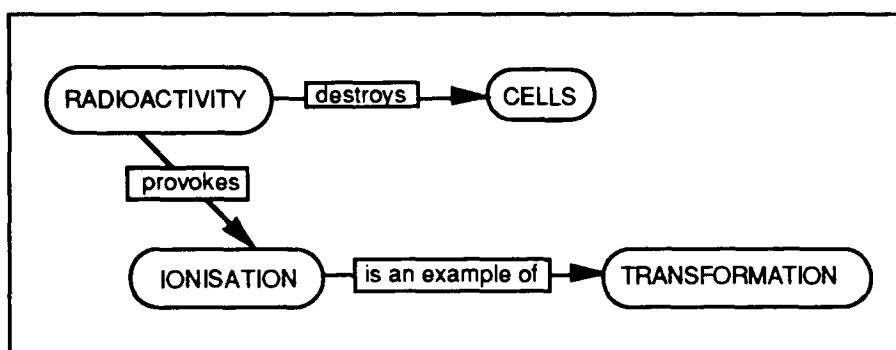

Figure 9.13: How radiation affects matter II (MS2)

In fact, all nets contained reference to damage caused by ionising radiation to cells and to it as causing cancer or destroying the person or cells. In half of the nets this view is more balanced, with students mentioning that radiation is also used to treat (destroy) cancer. This mainly 'negative' view of radiation is consistent with students' answers in the questionnaire study, which were found to be related to a factor called danger (see chapter 7).

Many nets contained references to the fact that radiation, radioactivity and radioactive materials can be seen as 'kinds of' as well as 'producing' particles and/or rays. Examples of this are shown in figure 9.14. Again, the similarity in the associations made in connection with any of the three concepts (radiation, radioactivity and radioactive material) seems to reinforce the argument for the undifferentiation among them.

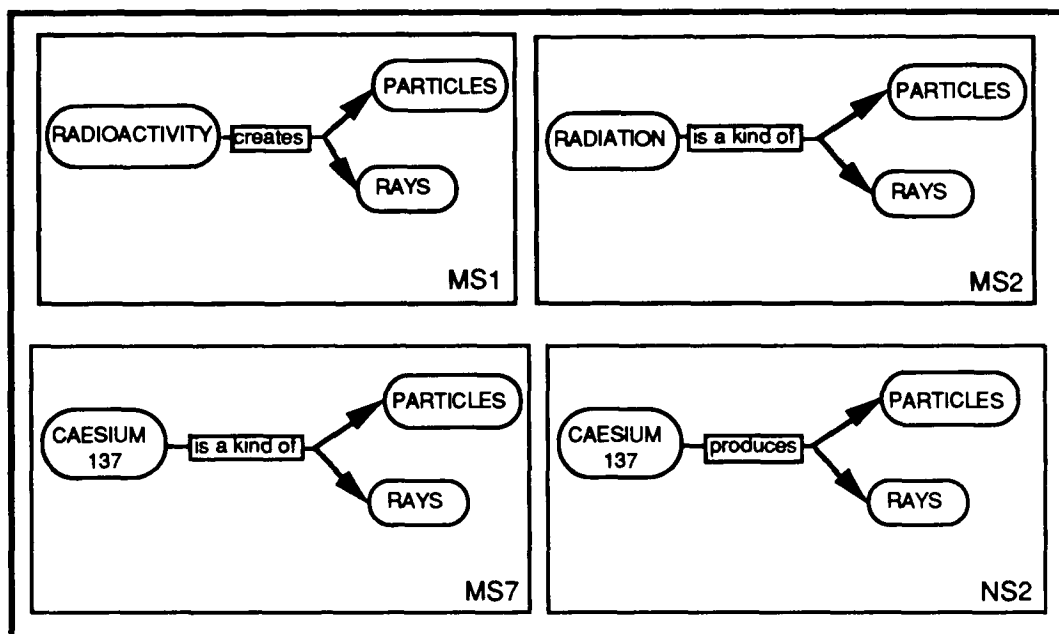

Figure 9.14: The Undifferentiation of the Concepts.

There were three types of information which were left out in the construction of the nets. One was the characterisation of radioactivity in terms of the process of disintegration and the formation of new atoms, which appeared only in three out of the thirteen nets analysed. Another related to activity decreasing with time and the influence of time in the effects of exposure to ionising radiation. A third was that concerning the probabilistic effects of exposure to ionising radiation. In this case, however, it is not possible to determine to what extent this is due to constraints imposed by the nature of the links allowed or whether it reflects a deliberate choice of the students. Nevertheless, it can be argued that a similar problem of awkward representation could have also affected representing the idea of activity decreasing with time. Some students insisted on having this represented in the net, making it clear this is what they meant by links of the type 'Time -- allows --> Disintegration' (MS3). "Allows" was, therefore, used to express "happens as time goes by".

## **9.2 HOW CONSISTENT ARE THE RESULTS ACROSS DIFFERENT CONTEXTS?**

Students' ideas and explanations about radioactivity can be summarised with the aid of the systemic network presented in figure 8.2. In this network the different aspects discussed are organised according to the same categories used to guide the quantitative analysis of the semantic differential grid. They are *materiality*, which

here was expanded so as to acquire a wider-in-scope view of *existence*, *activity* and *knowability*.

Overall, students appeared to have views which are consistent with those which emerge from analysis of the questionnaire. As far as the nature of radiation/radioactivity/radioactive materials are concerned, the responses they give in the interviews possess the same broad features identified in the analysis of the questionnaire study, namely, a constant association to danger, the mentioning of a rather unclear concept of "strength", the doubts about a material or immaterial nature, the certainty about an active destructive character and so on.

It is also interesting to note that, in the interview, some of their choices for both associations to and properties of the concepts are made explicit. For example, the large number of choices in the questionnaire for x-rays as something that resembles radioactivity/radiation/radioactive material has a parallel in the interview study, where many students refer to x-rays to illustrate applications of radioactivity, considering them as essentially the same entity.

Associations with light and heat for example are frequently made and are used to explain the way radiation propagates in a space. What they mean when they say it is like light, heat or a gas is respectively:

*"C: It is like light... it can fill a big space...by its own means.. it's the way it is" (NS3)*

*"R: ... you were asking about an example [of something it resembles]... I think heat is an example. Suppose there is a fire on the corner, on the other side of the room... it will warm up the whole room.*

*"A: ... [it can be] as a kind of light... well, it's even bright... but it doesn't pass through like light... I don't know... I think it's more like a gas... it could escape through the most narrow gap..." (NS6)*

Similarly many references to it being like a stone, like a kind of solid, made of particles, as a kind of compressed powder are made. Being like fine powder would be consistent with the fact that it spreads easily and attaches to objects it has contact with. Being like a cloud suggests that it can travel around.

The incompatible complex multi-faced views on the material nature of radiation/radioactivity/radioactive material is also present in the accounts of students who find it difficult to commit themselves to a position of considering any of the

concepts as material or immaterial. There is also evidence that the way radioactive material can be distinguished from the other two is similar to that suggested by the distinctions made by students when answering the questionnaire.

The active character, the capacity of modifying and doing things to other bodies, and the possibility of moving around, are most frequently mentioned features as well as those related to danger, destruction, risk and harm and the rather unclear notion of "strength".

There is also a great deal of consistency between answers given to questions concerning the possibilities of "getting to know" them as, according to the results of the choices for the *knowability* scales in the questionnaire. There, students appeared to disagree whether it can be understood or, somehow, managed. In the interviews they make this explicit by saying it is actually understood to different extents by different people and that only in special circumstances can it be detected, measured or controlled.

---

---

## CHAPTER X

### WHAT DO TEACHERS SAY?

---

---

#### **10.1 ORGANISATION OF THE ANALYSIS**

In this chapter results of a complementary study carried out with teachers will be reported. They refer both to a questionnaire and to an interview study. The questionnaire contained identical questions to those answered by students concerning the nature of knowledge ("Is Radioactivity Like...?" and the semantic differential grid). In addition, teachers were asked to predict students' answers in the nature of knowledge questions, and to give their opinions of students' interests and sources of information. They were also asked to classify and exemplify the most common types of doubt they thought students have on the subject.

Interviews concerned mainly: (a) teachers thinking about students' ideas; (b) recollection of questions students asked at the time of the accident in Goiânia; (c) teachers' explanations about radioactivity.

The teachers' questionnaire is shown in Appendix 10.1. The presentation of results will follow under the same headings used when presenting students' results so as to allow a more direct comparison between teachers' predictions and students' answers. In the interviews there was reference to the pieces of news and to the text used in students' interviews, and given appendices 5.1, 5.2 and 5.3.

#### **10.2 KNOWLEDGE AND SOCIETY**

Questionnaires were sent to 50 teachers and, out of these, 27 were returned completed. 7 were Biology teachers, 11 were Chemistry teachers and 19 were Physics teachers. They were in their mid-thirties, on average, and all of them had

two years experience or more, with half of them with more than five years experience.

When asked to give their opinion about students' level of interest in radioactivity, one half of the teachers said they considered that students had either very little or superficial interest in the topic whereas the other half considered them to have a reasonable interest in it. This illustrated in chart 10.1.

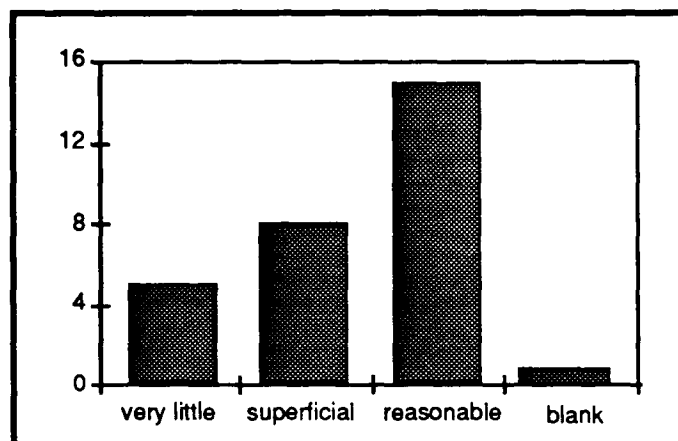

Chart 10.1: Totals for question "In your opinion, students' interest in knowing more about radioactivity is ..." (figures in the vertical axis are actual numbers of teachers).

The teachers' predictions can be seen as a little pessimistic in that most of the students, claimed to have either some or much interest in radioactivity related topics (see section 7.2, chapter 7).

Teachers were also found to have a good idea of students' most likely sources of information. The results show that the options given were actually ranked in the same order they appear in students' answers (see section 7.2, chapter 7), with TV being more often chosen than all other options, followed by the newspapers and magazines, school related sources (teachers, school books, etc) and a small minority of other possible sources like, for example, talking to friends. Chart 10.2 shows the totals for teachers' choices in this question.

WHAT DO TEACHERS SAY?

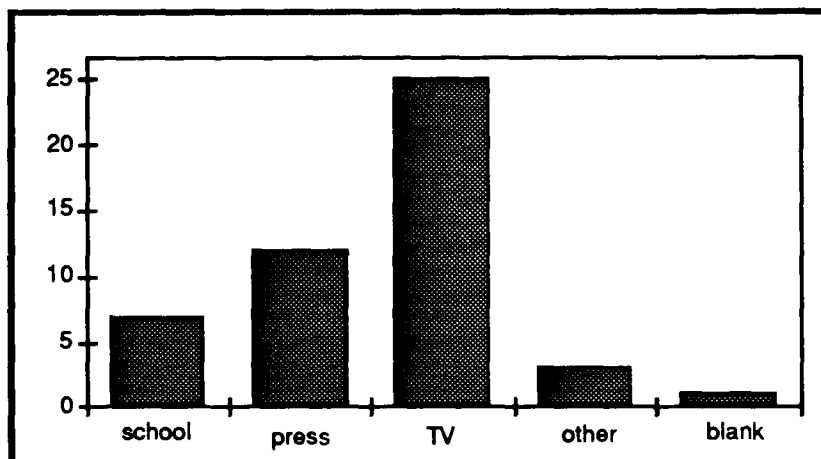

Chart 10.2: Totals for answers to question: "Where do you think students got most of their knowledge on radioactivity?" (figures shown in the vertical axis are total number of choices for each option).

Information on what teachers remembered to be the most common questions asked by students at the time of the accident at Goiânia was also obtained. In this question teachers were able to tick more than one option (and did so: the ratio of choices per teacher is approximately 3.4). Seven alternatives of broad headings were given as well as a blank space if the teacher wished to specify some other. The alternatives available mentioned kinds of questions or doubts related to:

- scientific explanations about the nature of radiation;
- how radiation affects both living and non-living matter;
- applications of radioactivity in Medicine;
- applications of radioactivity in power production;
- applications in problems involving nuclear waste;
- accidents involving radioactive material;
- security and control measures necessary when dealing with radioactive materials.

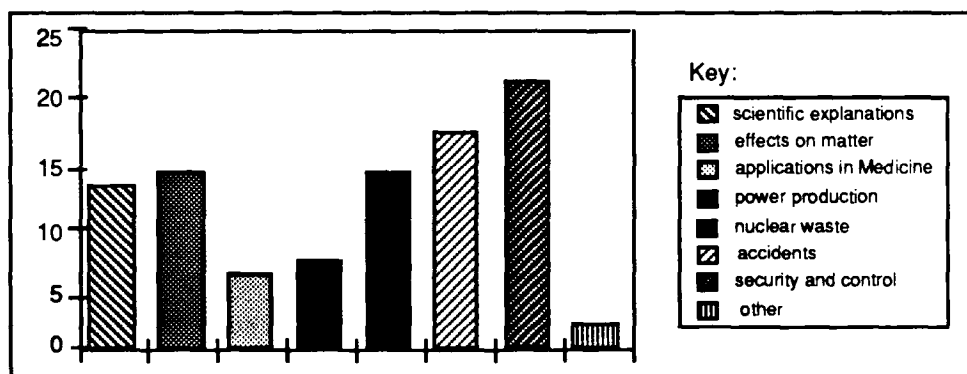

Chart 10.3: Teachers' recollection of most common kinds of questions asked by students at the time of the radiological accident of Goiânia.



As can be seen from Chart 10.3, the majority of questions teachers reported as being asked concerned either security and control measures necessary when dealing with radioactive materials, or were about accidents involving radioactive material. Ways through which radiation affects matter and scientific explanations about its nature were also mentioned by nearly half of the teachers. Applications in Medicine or Industry and problems related to nuclear waste were only ticked by a minority. One particular teacher remembered, although without exemplifying, questions generated by “mixing up cause and effects”.

In this case, teachers’ pattern of choices probably outline a representative picture of students’ concerns, at that time. The fact that most of the questions can be identified with the actual context of the event, together with an interest in problems related to nuclear waste, reflects a possible preoccupation with personal safety and consequences of the accident. Questions about the nature of radiation came lower and concerned mainly its interactions with matter. This picture also supports the earlier evidence about knowledge-in-context as being important (see chapter 6 and chapter 7).

Questions added to the list by teachers concerned primarily the issue of safety. Questions were divided between those which asked about precautions, and those which asked about actions to be taken in the event of “problems”. These include: *How to get information about it? How it would be possible to control both the use of radioactive materials and the levels of exposure to them? How to avoid radioactivity and accidents involving it?* There were also questions related mainly to the possibilities of “de-contamination” and of “moving away from it”. Examples of these questions are: *In relation to its applications in Medicine, which are the control measures of the exposure of: a technician who operates the equipment? the patient who is submitted to the treatment? How can de-contamination be done: in inert materials? in living beings?*

Many of the questions reported also related to the possible effects of radioactive/radiation/radioactive materials/ contaminated bodies, primarily on human beings, followed by other living things (plants and animals), places (the city of Rio de Janeiro, which is far away from Goiânia, or the neighbourhood of the junk-yard where the capsule was opened) and food. Examples of such questions were: *When it does not kill, which changes in the organism are likely to appear in men, plants and animals? Can the city of Rio de Janeiro be affected by the radioactivity from the accident of*

*Goiânia? How are things in the place where the accident happened now? Is radioactivity contagious?*

Lastly, and sometimes not very clearly formulated, there were questions about the nature of radioactivity and some of its possible effects. What it is; how long its effects can last and; how it can be detected, were examples of some questions raised by students.

With respect to the most common types of doubts students held, some teachers claimed to have been able to identify cases where there was a “total and complete ignorance about the existence of background radiation”, “a wide-spread and deeply-rooted belief that any form or dose of radiation was harmful” or, alternatively, “lack of knowledge about safe uses of radiation”.

Teachers’ recollection do seem to be quite accurate when compared to students’ own recollection about questions they asked and doubts they had at that time, though they are presented and described in a more elaborated and synthetic way. Referring back to section 6.2.3.1.5, where students’ questions are described we saw that, in their opinion, the most problematic aspects of radioactivity are identified with contradictions about risks and benefits associated with its use as well as about its nature and real existence. Many of the questions that teachers could remember, summarise and illustrate just these points.

### **10.3 NATURE OF KNOWLEDGE**

#### **10.3.1 “IS RADIOACTIVITY LIKE...?”**

Teachers were able to predict rather well what students had actually responded to this question, namely that radioactivity can be seen in many different ways, as like many different things. They were also broadly right about the pattern of students preferences, that is, associating radioactivity more often with immaterial active entities, such as, *energy*, *rays x-rays*, etc and less often with tangible non active entities such as *water* and *object* . The table below shows totals and percentages of yes answers to each entity.

Entity	Count	%
ENERGY	25	86
RAYS	24	83
X-RAYS	23	79
CLOUD	20	69
DUST	20	69
HEAT	19	66
GAS	19	66
WAVES	17	59
LIGHT	17	59
SMOKE	16	55
M <sup>g</sup> FIELD	13	45
ELECTRICITY	12	41
AIR	11	38
MOVEMENT	5	17
SOUND	3	10
WATER	1	3
OBJECT	1	3

Table 10.1: Teachers' predictions about students responses to question: "Is radioactivity like...?" (totals and percentages) N=27

A classification of the proposed entities according to their degree of resemblance to radioactivity was obtained by means of a cluster analysis. Figure 1.1 depicts the resulting dendrogram and identifies the three main clusters. Similarly to the cluster analysis performed on data from students' responses to the same question there were three main clusters.

Cluster 1 contains *smoke, gas, air, dust* and *cloud*, and was interpreted as relating to a **dispersed** (cloud-like) character. *X-rays, rays, energy, heat, light* and *waves* are gathered in Cluster 2, which was named **immaterial influence**, as it puts together immaterial active entities. Cluster 3, formed by *object, water, movement, sound, electricity* and *magnetic field*, is harder to interpret as it joins both tangible material non active entities (object and water) and immaterial active entities (such as electricity and magnetic field and, perhaps, sound). It was considered as probably relating to **movement**.

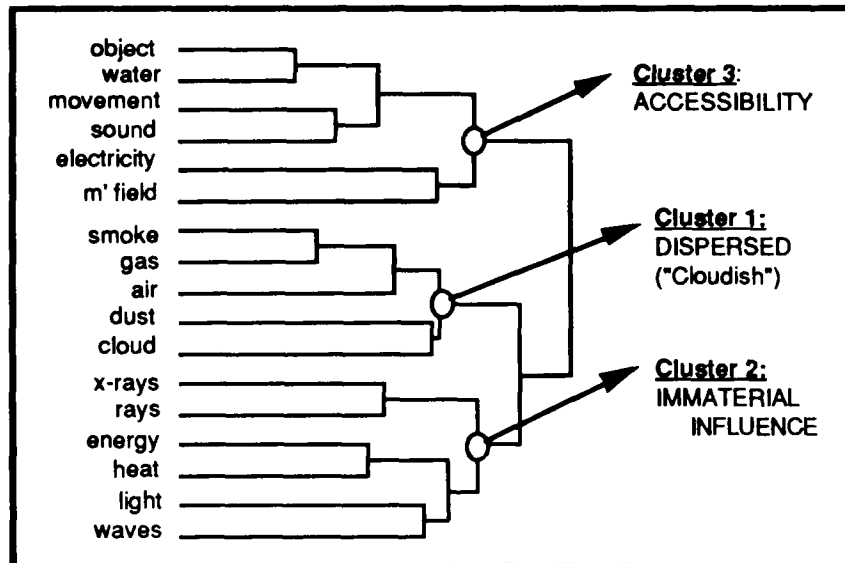

Figure 10.1: Cluster analysis (complete linkage) for teachers' predictions on students' answers to: "Is radioactivity like...?"

Comparing the results of the analysis on both teachers' and students' data (which is shown in section 7.4.1), it is possible to identify some grounds for similar interpretations.

Cluster 1, named **dispersed**, is the same in both analyses and Cluster 2, called **immaterial influence**, contains almost the same entities as the first cluster named, **intangible active**, in the students' analysis. The only exception is *waves*, which appears associated with light and x-rays in the teachers' opinion. This overall similarity does not hold for the case of cluster 3 from the teachers' analysis, **accessibility**, which cannot be straightforwardly associated with **materiality**, as in the case of Cluster 3 from students' analysis.

Teachers' responses to each scale were also factor analysed. Again, the results obtained corroborated the proposed interpretation for the cluster analysis. The Orthothran/ Varimax solution has 7 uncorrelated factors, all with eigenvalues greater than 1. The Bartlett sphericity test gives  $\chi^2 = 279.353$  for 152 degrees of freedom which corresponds to a probability of 0.0001. Table 10.2 shows the factor loadings for each factor along each variable for the preferred orthogonal transformation solution.

WHAT DO TEACHERS SAY?

ENTITIES	Factor1	Factor2	Factor3	Factor4	Factor5	Factor6	Factor7
air	.722	.050	.118	-.276	-.051	-.265	.022
waves	-.239	.079	-.668	.376	.069	.124	.330
cloud	.402	-.277	.177	-.233	.408	-.588	-.022
rays	.068	-.309	-.112	-.081	.288	.702	-.120
dust	.488	.211	.425	.066	.365	.073	-.300
water	-.175	.109	-.052	.084	.855	.096	.157
x-rays	-.265	-.355	.336	.287	.101	.341	.059
m' field	-.273	.294	.193	-.143	-.009	.747	.245
electricity	-.035	.029	.030	.042	.133	.058	.949
heat	-.365	.723	-.141	.245	-.006	-.032	.125
object	-.220	-.706	-.157	.090	.010	-.181	.309
light	-.103	.044	-.054	.874	.169	-.253	.068
energy	.100	.838	-.065	-.054	.130	-.080	.129
sound	.275	-.053	.297	.664	-.213	.402	-.052
movement	.002	-.019	.893	.164	-.092	.042	.163
gas	.902	.091	-.046	.079	-.180	-.061	.163
smoke	.917	-.081	.061	.073	.016	.016	-.204

Table 10.2: Factor loadings from factor analysis on teachers' predictions to students' responses to "Is Radioactivity Like...?" (Orthogonal Transformation solution).

Factor 1 puts together invisible tenuous substance-like entities, namely *smoke*, *gas*, *air*, *dust* and *cloud*, and, for this reason, was given the label **dispersed**. Factor 2 has high loadings only in the cases of *energy* and *heat* and, negatively, in *object*, and was named **energy**. The third factor relates, perhaps, to **physical movement** because of high loadings on *movement* and *dust* and, negatively, on *waves*. Factor 4 was labelled **wave** and is highly loaded on *light*, *sound* and *waves*. Factor 5 probably relates to a **substance-like** character and has high loadings on *water* and *cloud*. High loadings on *magnetic field*, *rays* and, negatively, *cloud*, suggested an interpretation of factor 6 as **invisible influence**. Finally, factor 7 appears to be a single-variable factor as it is highly loaded uniquely on *electricity*, being consequently called **electricity**.

The interpretations given to factors 3, 5 and 7, physical movement, substance like and electricity respectively, help to understand better the cluster analysis earlier performed on the data as it splits cluster 3 (movement) in three aspects: (i) moving entities namely, substance-like (*object* and *water*); (ii) wave-like (*sound*) and; (iii) a kind of flow (*electricity*). The other factors have a simple correspondence in the clusters: factor 1 and cluster 1 both bringing together dispersed substance-like entities and factors 2, 4 and 6 (energy, wave and invisible influence) having high loadings on the entities which form cluster 2 (immaterial influence).

Combining the results of this factor analysis with information about teachers' actual choices, it seems that, according to teachers' views, students would consider radioactivity as actually dispersed and energetic, perhaps as some kind of moving particles. They also think students may also conceive it as wave-like or as a form of invisible influence, perhaps as a kind of "electricity".

Students' answers (section 7.4.2.3) and teachers' predictions differ not so much in terms of the main features but in their degree of specificity. Both interpretations make use of general features such as materiality, activity and dispersal.

### 10.3.2 PROPERTIES ATTRIBUTED TO ENTITIES

Teachers were also asked to predict students' answers for the semantic differential grid. Responses were scored in the same way as for students (section 6.2.3.3.2). The RevMeans vs Concur plot is shown in figure 10.2, with cases in bold corresponding to the most often chosen extreme of the scale.

Distinctions related to activity are those which correspond to the most polar views and about which there is the highest level of concurrence. Thus, according to teachers, students would consider the concept of radioactivity as, for example, *powerful, energetic, moving, risky, harmful, destructive* (as opposed to creative), *destructive* (as opposed to productive), *difficult*, as something that *makes other bodies radioactive* and that *has to be made*. They also predicted, though there is more disagreement between them in this case, that features such as *detectable, complex, can be measured, special, active, strong, invisible, amorphous, intangible, unfamiliar, passes through matter, lasting, immaterial, moves by itself and alive*. would be thought of as applicable to radioactivity by students.

Cases about which teachers, as a group, were unsure relate to features *is always there vs comes and goes, useful vs useless, natural vs artificial*, and *acts by contact vs acts by itself*. There were opposite views about students' preferences the case of properties such as *light vs heavy, uncontrollable vs controllable, abstract vs concrete, not composed...vs composed of particles, momentary vs eternal, increasing vs decreasing, known vs unknown, spread vs located*, though there was a slight tendency for the underlined pole to be more often chosen. Nonetheless, in the cases of the scales *perceptible vs imperceptible, permanent vs transient, acts by*

*contact vs acts at a distance, useful vs useless, is always there vs comes and goes, there was no preferred pole whatsoever.*

If teachers' predictions are classified along the previously categories of Materiality, Activity and Knowability (see Table 7.6), it is seen that teachers, in general, concur about Activity scales. The level of concurrence decreases in relation to some of the Materiality scales (such as *intangible vs tangible, invisible vs visible, etc*). Scales about which they are likely to hold opposed views are those about Knowability and some Materiality scales (such as *momentary vs eternal, abstract vs concrete, spread vs located, not composed... vs composed of particles, etc*).

Teachers' predictions match students' answers reasonably well, as indicated by the correlation of 0.893 between students' and teachers' mean scores. The matching is especially good, in the Activity and Knowability categories, with correlations of 0.960 and 0.910 respectively. With respect to Materiality scales, the correlation of 0.707, though still high, is lower than the others.

This good agreement can be seen as an argument in favour of the decision to consider the results of the factor analysis performed on students' responses as meaningful. At that time, this decision was based on the results of the Bartlett sphericity test and on the interpretability of the factors. The fact that when asked to predict what students' responses would be like, teachers give remarkably similar answers, reinforces our belief in the assumption that the structure of these responses is, in fact, "real" and not a mere consequence of random correlations. This holds also if one speculates about the possibility of teachers having answered the questionnaire according to their own beliefs about radiation, which would then imply that they are not much more informed than their students. This possibility will be discussed later, when data from the interviews are presented.

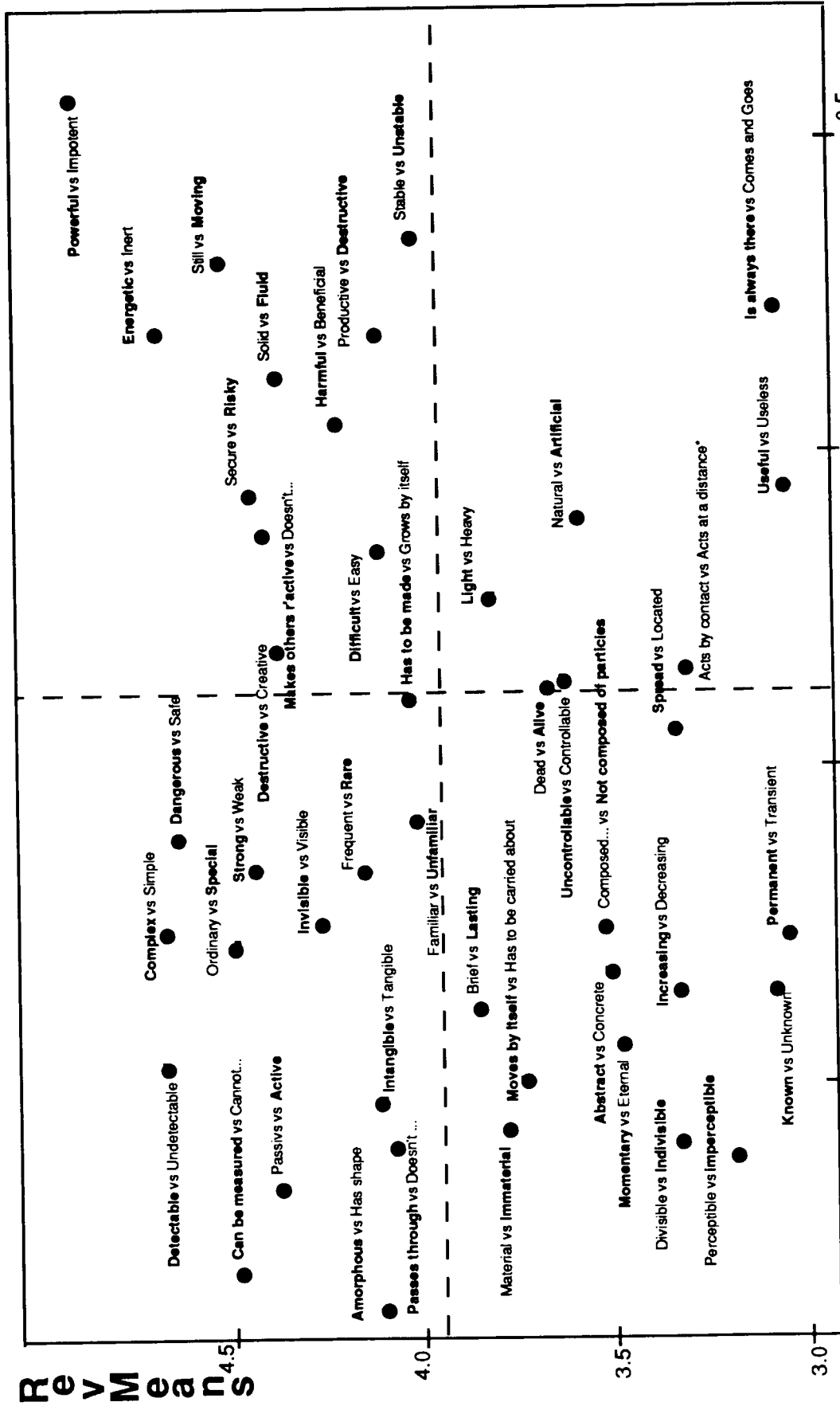

Figure 10.2: Reversed Means vs Concur Plot for Teachers' predictions of Students' answers to Question 2.  
 \* strongest preference for centre point of scale.



## **10.4 LEARNING AND THINKING: The Interview Study**

### **10.4.1 INTRODUCTION**

Interviews with teachers differed from interviews with students both in their focus and of their structure. Unlike students who were required to answer direct questions about their general conceptions on the subject and their understandings about a specific text, teachers were asked to talk about students' conceptions of and difficulties with radioactivity. Teachers interviews involved:

- (i) a discussion about the status they attributed to students' pre-conceptions;
- (ii) reporting their perceptions of students' understandings and doubts about radioactivity;
- (iii) predicting possible patterns of answer students would give to questions about the nature of and processes involved in radioactivity;
- (iv) proposing explanations for or approaches to the topic in the classroom;
- (v) expressing their views on some specific kinds of responses given by students when they were interviewed and;
- (vi) giving their impressions of and evaluating an explanatory text about ionising radiation in relation to its use for secondary school students.

### **10.4.2 THE SAMPLE**

Interviews lasted for one hour, in average, and were tape-recorded and transcribed at a later stage. Altogether, 16 teachers, 9 male and 7 female, were interviewed in groups of two or three. Seven out of these sixteen teachers had more than five years of teaching experience whereas the remaining nine had between two and five years. All had physics as their main subject though some had already taught basic science.

One particular characteristic of the sample is the fact that all of them, though in a varied degree, had regular contact with the Federal University Physics Education department. Their level of involvement might vary, ranging from casual visits for

help and advice, to systematic engagement in research activities in some of the projects based at the department.

As was expected, considerable difficulty was met in trying to arrange dates at which teachers could be interviewed in groups, because, most teachers, to increase their wages, may work for up to twelve hours a day at different schools, since they are normally paid by the hour. For this reason, and considering the limited time available, the researcher benefited from the fact that teachers who had some kind of regular contact with the university staff, in general, would meet, at least, once a week at the Physics Education department.

As said earlier, the involvement of teachers with the activities promoted by the department varied. However all of them would have some knowledge of the alternative conceptions research programme, though most would not be either familiar or up-to-date with the current literature in the field. Many others would be engaged in discussions of the teaching of science at secondary school.

### **10.4.3 SUMMARY OF RESULTS**

#### **10.4.3.1 General Observations**

In general teachers did not feel entirely comfortable and confident until they satisfied their curiosity about the aims of the interview. Some indication of that was the fact that some teachers needed to display their mastery of the subject mainly through casual comments even though they were never required to provide explanations. However, they soon relaxed and cooperated seeming happy to have the opportunity of discussing with colleagues and to thinking about their practice in the classroom.

During the interview teachers were encouraged to express their views as freely as possible and a debate in which different points of view could be challenged was stimulated. In order to avoid teachers feeling under pressure, the interviewer played the role of a mediator of the debate, rather than intervening.

#### **10.4.3.2 On Teachers' Knowledge of and Opinions about Students' Ideas**

When questioned about the status and importance that should be attributed to children's preconceptions in the classroom, most of the teachers acknowledged the value of both having information about what these ideas are like and trying to plan instruction accordingly. Students' preconceptions were regarded as mainly wrong ideas which do not relate to any deeper structure of reasoning but rather to a wrong way of observing daily life phenomena and to a lack of the necessary conceptual knowledge to understand scientific ideas.

In spite of that, most teachers agreed that it would be interesting to take students' previous ideas on the subject as well as any related experience as a starting point of a discussion. This was thought to be important in order to make the discussion either more accessible or meaningful to the student. Although this opinion that prior knowledge should be taken as a starting point to instruction was widely mentioned, there were very few occasions when suggestions about *how to do it* were made. The difficulty of doing so in the case of radioactivity was appreciated. This was based upon the remoteness and non-familiarity of the subject, which was characterised by many teachers as *too sophisticated*, and *not accessible* to the average secondary school student.

In fact most of the teachers showed a belief that both the kind of prior knowledge as well as the possibilities of discussing related topics would differ with students' socio-economical background, with students from upper middle-class families having more access to reliable information.

Teachers also thought that students are bound to have problems with radioactivity related information because, when it happens to be available in the media, it is often unreliable, sometimes confusing, and tends to emphasise the bad consequences and effects of applications of radioactivity.

### **10.4.3.3 On Teachers' Perceptions of Students' Knowledge and Doubts**

In general teachers did not believe students knew much about radioactivity. This statement was often justified on the basis of the questions teachers remembered students asking them, which, in general they said as indicating almost a total lack of knowledge. Some teachers said the most frequent associations students would make would involve both fear and criticism, and that both were derived from ignorance of radioactivity related issues. Many teachers also remembered that many associations were made with the accident at Chernobyl.

The kinds of questions they remembered students having asked are very similar to those already reported by teachers who answered the questionnaire (PAGE 249). They can be roughly divided into two main headings: those concerning the effects of radiation in humans and in the environment and those related to a discussion on the need for and benefits one gets from this seemingly controversial source of energy. The first type of question was the most frequent. Some examples evoked by teachers and which were not present in the answers given to the questionnaire are<sup>1</sup>: *How is it capable of burning? For how long can the effects last? How do I know whether I am dealing with an infected [contaminated] person?* Examples of questions of the second type are: *How could we avoid it? Why is it allowed to be used? Do we really need radioactivity?*

One teacher could also remember that there were many questions, especially from lay people, about the status of the information broadcast by the media at that time. This worry is exemplified by questions such as: *Is it really true that radiation causes cancer? Is it so dangerous as it is said in the papers? Is this news true?*

The subject of contamination was often central in students' doubts. Most teachers believe contamination is seen by students as something which can hardly be avoided and the processes through which it might occur, though not made explicit, are not seen as problematic. One teacher remembers students did not appear to be puzzled by how milk could be contaminated by radiation; on the contrary, they expected it to be because cows had eaten contaminated grass. One teacher compared the fear people had at that time of shaking hands with a person who had been

---

<sup>1</sup>In these quotations, the pronoun it refers to a feminine subject, which suggests questions about either radiation or radioactivity and not about radioactive material (which is masculine in Portuguese).

exposed to radiation (and that would be therefore, according to their views, contaminated) as comparable to the fear they have of shaking hands with an HIV infected person. There are indeed many instances of questions, both as reported by students and teachers (Chapter 6 and earlier in this chapter) which revealed a preoccupation with the fact that people from Goiânia were being treated in Rio. As recalled by one teacher:

*"S: I remember many people worried because some patients were brought here to a hospital in Niterói, I don't remember exactly where, because they could be better assisted here. And I know some people who live close to that hospital and they used to wonder whether it was possible that they could suffer effects of contamination as well, because these people from Goiânia were being brought to Rio. There was also at that time, a sports event, a car race, I am not sure, but some sports event, and people who were going there, in the planes, they asked, 'what if this person sitting next to me is contaminated'? There was much fear and much ignorance too." (T2)*

In so far as people's interest in the subject was concerned teachers' general opinion was that it was circumstantial and did not generate any specific motivation to learn more about radiation. One teacher described their interest as occasional, just coming out of an episodic event, saying that, especially for the lower social classes, any violent crime would generate more interest and worries. In fact it was quite common for teachers to underestimate students' both prior knowledge of and interest in the subject as, in the questionnaire, when giving their opinion about students' interest in radioactivity (see section 10.2).

#### **10.4.3.4 On Teachers' Predictions of Students' Answers**

None of the specific questions asked in the interview with students, namely the contamination of distant bodies (in the case of the contaminated distant trees) and the possibility of keeping radioactive waste safe (as in the case of the deposit) had actually been the subject of discussion by teachers with their students. This made some teachers quite hesitant to speculate about students' possible answers. However, although not allowing themselves to venture too elaborate possible types of explanations, teachers, in general, could predict quite accurately many of students' answers. However, it was emphasised that they did not believe that if these answers were probed students would be able to sustain a coherent view about of the subject.

Teachers reported that the kinds of doubt both students and lay people (friends, relatives, acquaintances, etc) had at the time of the accident in Goiânia were related to: (i) the risks the population would be under and; (ii) the efficacy of the measures taken to control the situation. Questions about the necessary scientific concepts were less asked, and had mainly to do with the processes and mechanisms through which radiation/radioactivity acts.

A great majority thought that students would have said that the transport of radioactive material occurred through the air, especially because of the numerous and recurrent descriptions of the bright bluish powder that was rubbed into the skin, spread all over, etc, which could be found in the media reports. They also tended to believe that contamination is seen by students as mainly a transport of material stuff, needing a “carrier”, which could be the air, the wind, the rain, or even people. Nevertheless some teachers admit the possibility of associations with immaterial invisible emanations. They believe this view is very much influenced by current use of the words radiation and irradiation when referring to mental force, energy, etc, and indicating some sort of immaterial influence. Another possibility would be a ray-like view of radiation which, according to some teachers, would stem from other contexts such as laser pistols used by modern science fiction cartoon heroes.

In more general contexts other than the example of the contamination of the distant trees which was offered, the opinion was that students would favour associations with immaterial entities such as waves, fields or energy. One reason given is the fact that, similarly to these concepts, radiation is essentially an invisible but very active entity. The closest to a material association they are prepared to get is a gas or a volatile substance.

They also predicted, quite correctly, that students would favour a view in which irradiation would inexorably lead to contamination either by the transport of radioactive material from one body to the other or through the action of these so-called invisible emanations altering the structure of other bodies.

Teachers also reproduced instances of what was called “deriving knowledge from social expectations”, as illustrated by the quotation below:

*“R: It was very common that they said: ‘How can it not be dangerous?! It certainly is, otherwise people wouldn’t make all this fuss about safety’. (T2)*

Nevertheless teachers tended to overlook and underestimate students potentiality to establish analogies and draw inferences from them. In fact most of them were quite surprised at the kinds of comparisons students proposed. The association with x-rays was thought of as plausible by all teachers, but one believed x-rays were more familiar than ionising radiation and seen as highly beneficial whereas radiation was too much associated with catastrophes. Others analogies mentioned by students, like that with the sun's rays, were dismissed on the grounds that students would not appreciate their similarity nature, saying that the sun was too much associated with pleasant leisure (beaches and sunbathing) to evoke the harm it may cause to health. Teachers also doubted that some apparent ambiguities in the effects of exposure to ionising radiation, namely that it may both cause and help to treat cancer, were perceived by students. Only one teacher admitted that students could be aware of such contradictions but doubted a fruitful discussion would follow from that as they did not possess the necessary background knowledge.

#### 10.4.3.5 On the Difficulties in Explaining Radioactivity

Overall the main difficulties mentioned by teachers (in order of the frequency with they appeared) were:

(a) *students lack the necessary background knowledge for an informed discussion* . Basic knowledge of atomic chemistry, atomic structure of matter, periodic table and properties of chemical elements were thought of as fundamental and essential to a proper understanding of a scientifically accepted explanation.

(b) *that radiation is invisible* . It was very often mentioned that the main difficulty in making sense of such an entity was the fact that it was not possible to have even a mental image of what it is like, making attempts to picture it as something else even harder;

(c) *the fact that radiation can be both matter and electromagnetic waves* . Wave-particle duality and the fact that there is no unique correct explanation was thought of as problematic for students.

(d) *the lack of continuity between different contexts to which ionising radiation might be related* . This was often mentioned in the context of avoiding an artificial distinction between the "scientific" and the "real" world, perceived as a tendency in

students' way of thinking that is very often crystalised by how school science is presented to them.

When talking specifically about how to deal with the topics radiation/radioactivity in the classroom, teachers insisted on the argument that this would be virtually impossible to do, unless students already had previous knowledge of basic atomic chemistry.

Many teachers mentioned that a great deal of abstract thinking was required in order to understand radioactivity and that this was a problem for students who tended to prefer a more concrete approach. One teacher envisaged this as a crucial obstacle in communicating scientific ideas to students and to the public in general. The only way to overcome that is, in his own words:

*"JC: It is difficult for them to understand it because it's difficult for them to understand that the concept [of a field] is a model. They want 'concreteness', it's hard for them to grasp that radiation is a model that you construct so as to explain certain phenomena you observe. This is very difficult to understand because it involves working at a more abstract level."* (T5)

Thus, according to some teachers, a step towards a solution would be to help them to realise what science is, what scientific practice is about and the roles of models in science. This goes in the same direction as a comment made by another teacher referring to the problems of students being presented with two alternative valid explanations about the same entity:

*"F: It's necessary to demystify science and the notion that there absolute truths"* (T8)

Other suggestions were to explore situations which were already familiar for students, for example sunlight and necessary precautions to avoid being burnt, security measures for people who operate X-ray equipment, etc. Some analogies with thermal radiation were also proposed, both at the level of their nature and at the level of processes. Nevertheless the view that the discussion should be mainly about effects, consequences of exposure and applications as opposed to a highly theoretical account of structure and properties of the matter was expressed as a consensus.



Without exception teachers found analogies helpful, the best one being that with x-rays, since they are part of daily life and possess the same nature as ionising radiation. The fact that there are also limits for safe exposure and that it causes similar effects on the human body were also thought to be useful in so far as comparison could be made. Analogies with heat were also thought to be especially helpful, as it would instantiate another context where something you cannot see affects you, as well as having a delay in feeling the effects.

An important point made by several teachers was that it is necessary that they acknowledge the limitations in their professional capacities, which become evident in situations when they are required to discuss topics which are not part of the text-book programme.

#### **10.4.3.6 On Students' Typical Responses**

When teachers were presented with students' answers most of them were surprised with what students remembered about what they had read or watched at the time of the accident. They were also surprised by the fact that students had little difficulty in admitting a dual nature for radiation. Some analogies made by students in order to explain how ionising radiations affect the human body, for example in a similar way that a virus does, were thought to be curious but again teachers did not believe students would be committed to any particular view of the problem.

The analysis with a virus, especially with the HIV virus, was thought of as especially problematic as it limited the explanation to a material one. Again many teachers admitted not knowing enough about either process. However, it was agreed that teachers should benefit from this association to try and promote a *dissociation* of the two concepts, especially because both topics were of public interest and concern.

#### **10.4.3.7 On Evaluating the Text**

In general teachers thought the text was very good and that many important points about the nature of radiation are made clear. They also thought that it could be used in secondary schools, perhaps in the teaching of basic atomic chemistry. They also predict that the text would be readily understood by an average secondary school

student, though pointing out that the discussion of rates of disintegration and different unities of measurement would not be a straightforward, as students experience many difficulties in Maths (see section 9.1.1).

Most of them suggested some adaptation of the final paragraph which is considered to have "*too much information*" that is not particularly relevant to the layman. Special attention is also thought to be needed when discussing the relationship between mass and energy when one element transforms into other.

### **10.5 SUMMARY OF RESULTS**

Overall teachers were able to make reasonably correct predictions about student's answers and doubts. Although they acknowledge students' prior knowledge and its importance they tend to see them as an obstacle which prevents learning. Nevertheless, some teachers were surprised with answers students could give and doubtful that some could be explored in discussions with the classroom.

Most of them also said that explanations about radioactivity should make reference to some kind of analogy, though emphasising that this attempt could also be impaired by pupils' deficient background knowledge.

Almost all teachers acknowledge the social implications of science though, in their opinion, this should not constitute the major focus of science instruction. They could probably be seen as being more sympathetic to a view in which only occasional though regular reference is made towards STS issues in the classroom.

---

---

## CHAPTER XI

### CONCLUSIONS

---

---

#### 11.1 INTRODUCTION

This chapter presents the main conclusions of this research discussing them in relation to the original research questions. It also discusses the implications of the results for further research and for curriculum planning.

#### 11.2 OVERVIEW

This thesis investigated the understandings selected groups had of scientific information related to a matter of public concern. Secondary school students and teachers were chosen so as to focus on problems related to communicating such kind of ideas for the purpose of formal instruction.

The research questions were conceived in a framework which takes into consideration the relationships between Science and Education as institutions within society. Therefore the questions concern aspects relevant to the main dimensions of interest of Science and Education, namely the theoretical, social and educational. They are best located in the intersections of the diagram shown in figure 2.2 and reproduced below.

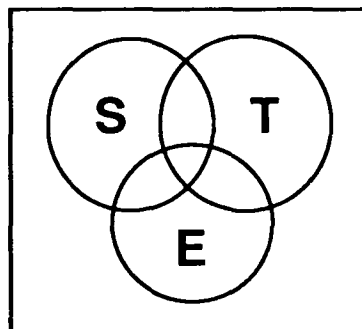

For example, questions concerning the nature of the entities, processes and causation involved in students' explanations of radioactivity concerned an interaction between the theoretical and the educational dimensions. Questions concerning sources of information and how people see themselves in relation to this kind of knowledge relate to the connection between the educational and the social aspects. Questions about how scientific ideas are communicated to the lay person refer to the theoretical-social link.

The research questions also reflect the nature of the object of this study, namely people's potential ability to make sense of new information as opposed to a static picture of people's knowledge about a given topic.

Since the nature of the information wanted was varied, it was decided that different instruments should be used in the data collection. That enabled data to be compared across different contexts and suggested possible ways of understanding better the relationships between Science, Education and Society, as illuminated by a particular case.

### **11.3 SUMMARY OF RESULTS**

#### **11.3.1 The Theoretical - Educational Link**

##### **What are people's conceptions about the nature of radioactivity?**

*Radioactivity appears to be seen as some kind of active intangible entity and not differentiated from radiation or from radioactive material.* This is valid for students from different socio-educational background (see section 7.4.1.1 and section 7.4.2.2) and is in consonance with teachers' predictions of students' answers (see section 10.3.1 and 10.3.2). More specifically, all three concepts are perceived as not readily accessible to the senses and as essentially dangerous. Students are unsure of about features concerning a possible material existence for the concepts and disagree about their natural existence and about the possibilities of getting to know them (see section 7.4.2.2). See also Chapter 9.

**What are people's conceptualisations about the causation processes related to radioactivity?**

*All concepts are seen as essentially active and powerful, capable of provoking transformations in matter, of causing destruction; perhaps autonomous and maybe acting by contact.* Where students agree about their power to cause harm and destruction, there is disagreement about how they appear to act upon other bodies. This seems to relate to disagreement about them being dispersed or locatable and material or immaterial (see section 7.4.2.2). Whatever its nature, the agent is believed to have to 'reach' the object it acts upon, either across a space by rays or by direct contact (see section 8.4.2). There is also disagreement about their ability to grow or move by themselves and there is indication that their action might be affected by surrounding conditions (see section 8.6). Its great power of action, the little control one might have upon means of detecting and controlling it, give to radiation an almost *necessary* destructive character. Analogies are an important source of ideas concerning both nature and processes (section 8.5.1.1). There was also an observed tendency of associating similar effects and, from this similarity, deriving a similarity of their causes (see section 8.5.1.2).

**11.3.2 The Theoretical - Social Link****How do people see themselves in relation to knowledge of scientific information about radioactivity related matters?**

*Knowledge about radioactivity is seen as very specialised and complex, available and accessible to scientists who possess appropriate instruments to detect and measure it as well as the required background knowledge to explain it.* There is no clear consensus about radioactivity being perceptible, measurable or controllable (see section 7.4.2.2) unless by qualified professionals (see section 9.1.1). For the ordinary person, it is remote and unfamiliar, only perceived by its lethal effects, since evidence of its existence cannot be grasped through the senses. Overall, experts are seen as the only source of reliable information though, in different contexts, this may not be entirely intelligible, as students have re-stated their difficulties in understanding information they were given (see section 7.3.1). Nonetheless a reasonable level of interest is reported, especially that about practical aspects concerning safety in daily life context (see section 6.2.3.2).

There is very little or virtually no evidence of students drawing differences between science and technology spontaneously, which reinforces a hypothesis made (see section 2.2.2). Nevertheless, the practical, or pragmatic, and the conceptual, or theoretical, aspects of radioactivity seem to be linked somehow. Knowledge of radioactivity is also strongly contextualised, with frequent references to real events being found in students accounts (see section 8.4).

### **How are scientific ideas related to radioactivity communicated to people?**

*Information about radioactivity tends to be communicated in different forms depending on the context, with different focus and purposes, but, in most cases, presupposing some kind of previous background knowledge.* Sources of information are varied and students report having had more access to incidental sources on specific occasions (as in the coverage of the radiological accident at Goiânia by TV) though some information they found came through school related contexts (see sections 7.3). An analysis of different publications related to radioactivity matters shows that arguments are generally presented in a way that pros and cons are balanced, and based on the opinion of experts. Scientific explanations and social implications tend to be themes around which texts appear to be organised, the former being more often found in traditional text books and the latter in popularised accounts and in STS materials (see section 4.3). Explanations also very often appeal to external authority (experts' accounts, statistics, examples of well-known facts and related events) so as to lower the degree of dispute and questioning over matters concerning risks (see section 4.3.4). In so far as explanations of the nature of radioactivity is concerned, there seems to be a tendency to 'substantialise' radiation (see section 4.4). Analogies are also widely used in explaining radioactivity to a lay audience (see chapter 4).

### **11.3.3 The Social - Educational Link**

#### **What do people know about radioactivity?**

*Students knowledge of radioactivity includes episodic information about related events and and conceptions of danger, risk and power associated with radioactive materials. Most students are not familiar with related aspects such as the existence*

*of background radiation and with the use of radioactivity to sterilise food.* In general, students claim not to know much about radioactivity (section 8.4.1) and, in fact, many of their questions reveal areas where their most fundamental doubts are, namely, those concerning the nature of ionising radiation, the ways it affects matter, etc. What they appear to be really sure of is that anything which relates to radioactivity is potentially dangerous and harmful to mankind (section 6.2.3.1.5). Some continuity with other types of radiation (solar radiation, for example) is perceived and used as a basis for comparisons and inferences (section 8.4.5.2 and 8.4.5.3; also section 8.5.1.1).

### **What is the role of prior conceptions in understanding?**

*New related information appears to be interpreted against a background of diffuse knowledge about danger and risks, which are acquired mainly through the media.* Instances of previous knowledge being used to transform new information concern three main aspects: (i) notions of danger and risk associated with radiation is reinforced itself when the context is that of precautions, as in for example, examples concerning safety at work (see section 8.5.1.3); (ii) long-terms effects of exposure to ionising radiation and its low degree of predictability support a non-conserved conception of radioactivity and radiation (see section 8.4.5.2); (iii) the lack of means for the ordinary person to detect its presence and of suitable actions to be taken to control it, associated to devastating consequences of accidents involving radioactive material support a view of an intangible strong powerful destructive entity.

### **What lies beneath the most common types of misconceptions?**

*Most common types of misconceptions appear to be associated with ways the topic is dealt with by the media as well as with attempts to derive conclusions from comparisons with examples from other domains.* The undifferentiation between an entity and its properties is noticed both in students' responses as well as in media reports where a tendency to "substantialise" radiation was observed. The confusion between units of measurement also reflect at a superficial level, deeper confusions about the nature of concepts units refer to. Another important point is that what is taken as evidence of the existence of radiation consist basically of observable macroscopic long-term effects of its interaction with living tissue, mostly concerning cases of over-exposure to it. That appears to reinforce the idea that radiation is necessarily dangerous and possess<sup>25</sup> an immense destructive power. A

common strategy to infer knowledge is a 'pragmatic social strategy', with ideas about radioactivity being derived from obvious social expectations (see section 8.5.1.3).

**Which analogies and schemas from commonsense are assimilated?**

*People employ analogies so as to derive knowledge of and explain some of the properties of ionising radiation as well as of the mechanisms and processes through which it acts. Such analogies and schemas may be drawn from both familiar or remote domains. As an entity which can only be perceived through its effects in special contexts, much is left to be learnt or inferred through comparisons with other entities, processes or events which are already known. It is possible to see that people use analogies when referring to both the nature of radioactivity and its mechanisms of action (Chapter 8 and Chapter 9). Some of the analogies mentioned may also relate to different domains.*

## **11.4 IMPLICATIONS FOR WIDER ISSUES**

At a more general level, the findings of this research can be discussed in terms of their main implications for further research, curriculum planning and teacher training.

### **11.4.1 FURTHER RESEARCH**

Research on Science Technology and Society issues has concentrated on how children discuss related issues and less on how children understand the relevant science or what their interpretations and conceptions are. Knowledge about the former is both necessary and important but should not be prioritised over the promotion of understanding scientific concepts and processes in the classroom. This research has shown that many of students' doubts actually relate to lack of specific knowledge on the subject or to background knowledge necessary to interpret information.

This research has also shown that there is a need for understanding better the nature of students' ideas and the extent to which they are shaped by information acquired through incidental sources, like the media. Many of the inconsistencies and misconceptions students appear to have are actually replicated in newspaper articles



written by non-experts. More research seems to be needed to detect whether this corresponds to manifestations of the same kinds of ideas by different people or whether there is an influence of one on the other.

In so far as commonsense is concerned, these results show that people's ideas can be diverse and complex, though presenting a certain degree of regularity. It also shows that the genesis of such ideas and the sources from which they might originate from are not at all obvious. Further research is needed so as to understand better the role of more fundamental categories of thinking about objects and the real world (Mariani & Ogborn, 1991). When dealing with remote objects, which cannot be manipulated or experimented with, people appear to appeal to well known entities or events and to be able to decide on grounds of similarity between the two domains what could be appropriate analogies. At the core of these decisions, there lie most fundamental questions about the processes of identification and the role of similarity in constructing explanations. In the case of this research, there are indications that students may not simply be borrowing language from one domain and using it into another. It appears that students reason in terms of analogies, that is, derive inferences about unknown objects from their knowledge of a familiar domain. However, questions about how "mapping" from one domain to another is done as well as about the ontology of such domains of potential interest is important to understanding the role of similarity in explanations.

#### **11.4.2 CURRICULUM PLANNING**

Implications for curriculum planning include indications of students' preference for contextualised information over a more general context-free approach. This might suggest that materials to be applied in the classroom, should make reference to actual events and contexts which are familiar to the student.

Nevertheless, there is a risk here that an approach which is severely context-bound may yield limited and restricted opportunities for learning. On the other hand, there is a risk that a too general approach makes it more difficult for students to see things in perspective and to fully appreciate the nature of the problems under question.

Another problem concerns the strategy adopted to deal with the topic in the classroom. It was seen that a macroscopic description of phenomena appears to

accompany approaches which start by discussing the social implications of radioactivity, whereas a microscopic description is used when the point of departure is science itself. However, it is important to point out that the former position is adequate to tackle a specific problem, namely that of addressing social issues in the classroom. There is a risk, however, that this is seen as an alternative approach or a possible solution to problems concerning the teaching of scientific ideas, being considered by both teachers and students as more problematic and dependent on previous knowledge.

### **11.4.3 TEACHER TRAINING**

At the moment, in Brazil, pedagogic interventions concerning the introduction of a systematic discussion of social issues of science are very few and do not have an impact on the educational system as a whole. Science Technology and Society does not exist as discipline either. The opportunity students have of discussing social issues in the classroom are, therefore, very limited and depend on incidental occasional interventions which depend almost entirely on the good will of their science teachers.

However, it is important to point out that dealing with a discussion of social issues in the classroom may not be an easy task for teachers. It is certainly no less easy than dealing with the problems of adopting a teaching strategy which helps students to understand the relevant science so as to have an informed discussion about these issues.

In fact, many teachers considered themselves badly prepared (see chapter 10) and not very sure about their knowledge of science. There seems to be little information about how they feel in relation to what is involved in the management of such a discussion in the classroom, as well as about their abilities to conduct them. Preparing teachers to cope with the demands of Science Technology and Society courses would be essential if any such courses were to be established.

# **BIBLIOGRAPHY**

- Aikenhead, G. (1987). *Views on Science Technology and Society. Form CDN.mc4*. Department of Curriculum Studies, University of Saskatchewan, Canada.
- Aikenhead, G. (1990a). *Science Technology and Society Education Development: from curriculum policy to student learning*. Paper presented at the First Major STS Conference, Brasília, Brazil, June, 1990.
- Aikenhead, G. (1990b). *Consequences to Learning Science through STS: a research perspective*. Paper presented at the British Council's "Science Technology and Society Education" course, Department of Educational Studies, University of Oxford, September 10-20, 1990.
- Aitkenhead, A. & Slack, J. (eds.) (1985). *Issues in Cognitive Modelling*. London: Lawrence Earlbaum Associates Publishers.
- Andersson, B. (1986). *The Experiential Gestalt of Causation: a common core to pupils' preconceptions in science*. Eur.J. Sci. Ed., vol.8, No.:2, 155-171.
- Andersson, B. (1990). *Pupil's conceptions of Matter and its Transformations (age 12 - 16)*. Stud. Sci. Ed., 18, 53-85.
- Antaki, C. (ed.) *Analysing Everyday Explanation*. London: Sage. 1990.
- Arcà, M., Guidoni, P. & Mazzoli, P. (1983). *Structures of Understanding at the Root of Science Education: Part I. Experience, language and knowledge*. Eur. J. Sci. Ed., vol.5, No.: 4, 367-375
- Arcà, M., Guidoni, P. & Mazzoli, P. (1984). *Structures of Understanding at the Root of Science Education: Part II. Meanings for Formalisation*. Eur. J. Sci. Ed., vol.6, No.: 4, 311-319.
- Bartlett, F. (1932). *Remembering*. Cambridge: Cambridge University Press.

- Berger, A. (1982). *Media Analysis Techniques*. London Sage.
- Berger, P. & Luckmann, T. (1966). *The Social Construction of Reality. A Treatise in the Sociology of Knowledge*. London: Penguin.
- Black, M. (1962) *Models and Metaphors*. NY: Cornell University Press.
- Blalock, H. (1981) *Social Statistics*. London: McGraw-Hill.
- Bliss, J, Monk, M. & Ogborn, J. (1893). *Qualitative Data Analysis for Educational Research*. London: Croom-Helm.
- Bliss, J. & Ogborn, J. (1991). *A Psycho-logic of Motion*. Eur. J. Psych. Ed., vol.V, No.: 4, 379-390.
- Bratko, I. (1990). *PROLOG. Programming for Artificial Intelligence*. 2nd ed. Reading: Addison-Wesley Publishers Ltd.
- Brewer, W. (1987). *Schemas versus Mental Models in Human Memory*. in Morris, P. (ed.) (1987). *Modelling Cognition*, London: John Wiley & Sons.
- Brook, A., Briggs, H. & Bell, B. (1983) *Secondary Students' Ideas About Particles*. CLIS Project, Centre for Science and Mathematics Education, University of Leeds.
- Bryman, A. (1988). *Quality and Quantity in Social Research*. London: Unwin Hyman.
- Carey, S. (1987). *Theory Change in Childhood*. in Inhelder, B., de Caprona, D & Corm-Wells, A. (1987). *Piaget Today*. London: LEA.
- CEE (1977). *Science and European Public Opinion*. The Commission of European Communities.
- CEE (1979). *The European Public Attitudes to Scientific and Technical Achievement*. The Commission of European Communities.

## BIBLIOGRAPHY

---

- Chatfield, C. & Collins, A. (1980). *Introduction to Multivariate Analysis*. London: Chapman & Hall.
- Child, D. (1978). *The Essentials of Factor Analysis*. London: Holt, Rinehart & Winston.
- Clement, J. (1983). *A Conceptual Model discussed by Galileo and used intuitively by Physics Students*. in Gentner, D. & Stevens, A. (eds) (1983). *Mental Models*. London: Lawrence Earlbaum Associates Publishers.
- CNPq (1987). “Q que o brasileiro pensa da ciência e da tecnologia?” A Imagem da Ciência e da Tecnologia junto à população urbana brasileira. Relatório de Pesquisa. Brazil: MCT, CNPq, MAST.
- Cohen, L. & Manion, L. (1989). *Research Methods in Education*. 3<sup>rd</sup> ed., London: Routledge.
- Delacôte, G. (1987). *Science and Scientists: public perceptions and attitudes*. in O'Connor, M. & Evered, D. (1987). *Communicating Science to the Public*. Chichester: John Wiley & Sons Inc.
- Delamont, S. (1989). *The Fingernail on the Blackboard? A Sociological Perspective on Science Education*. *Stud. Sci. Ed.*, 16, 25-46.
- DES (1985). *Science in Schools 1981-1985*. London: DES.
- diSessa, A. (1989). *Knowledge in Pieces*. in Forman, G. & Putfall, P. (eds.) (1989) *Constructivism in the Computer Age*. London: LEA.
- diSessa, A. (1983). *Phenomenology and the Evolution of Intuition*. in Gentner, D. & Stevens, A. (eds) (1983). *Mental Models*. London: Lawrence Earlbaum Associates Publishers.
- Driver, R. & Easley, J. (1978). *Pupils and Pradigms: a review of literature related to concept development in adolescent science students*. *Stud. Sci. Ed.*, 5, 61-84.

## BIBLIOGRAPHY

---

- Driver, R. & Ericksson, G. (1973) *Theories in Action: Some theoretical and empirical issues in the study of students' conceptual frameworks in science*. Stud. Sc. Ed., 10, 37-68.
- Driver, R., Guesne, E. & Tiberghien, A. (1985). *Children's Ideas in Science*. Milton Keynes: Open University Press.
- Duit, R. & Pfundt, H. (1985). *Bibliography. Students' Alternative Frameworks and Science Education*. 2<sup>nd</sup> ed., Kiel: IPN.
- Duit, R. & Pfundt, H. (1991). *Bibliography. Students' Alternative Frameworks and Science Education*. 3<sup>rd</sup> ed., Kiel: IPN.
- Durant, J, Evans, G. & Thomas, G. (1989). *The Public Understanding of Science*. Nature, vol. 340, 6 July 1989, 11-14
- Durant, J. & Thomas, G. (1987). *Why Should we Promote the Public Understanding of Science?* in Scientific Literacy Papers, summer issue, 1-15, Department of External Studies, University of Oxford.
- Eijkelhof, H. & Millar, R. (1988). *Reading about Chernobyl: The Public Understanding of Radiation and Radioactivity*. School Science Review, 70, 251, 35-41.
- Eijkelhof, H. (1990) *Radiation and Risk in Physics Education*. Utrecht: IVLOS.
- Eijkelhof, H., Klaassen, K., Linjse, P. & Scholte, R. (1990). *Perceived Incidence and Importance of Lay-Ideas on Ionising Radiation: Results of a Delphi-Study Among Radiation Experts*. Sci. Ed., 74 (2), 183-195.
- Everitt, B. & Dunn, G. (1983). *Advanced Methods of Data Exploration and Modelling*. London: Heinemann.
- Flood, W. (1957). *The Problem of Vocabulary in the Popularisation of Science*. Institute of Education, University of Birmingham.

- Forman, G. & Putfall, P. (eds.) (1989). *Constructivism in the Computer Age*. London: LEA.
- Franklin, A. (1978). *Inertia in the Middle Ages*. *The Physics Teacher*, 201-207.
- Gentner, D. & Stevens, A. (eds) (1983). *Mental Models*. London: Lawrence Earlbaum Associates Publishers.
- Gick, M. & Holyoak, K. (1983). *Analogical Problem Solving*. in Aitkenhead, A. & Slack, J. (1985). *Issues in Cognitive Modelling*, London: Lawrence Earlbaum Associates Publishers.
- Gilbert, J. & Swift, D. (1985). *Towards a Lakatosian Analysis of the Piagetian and the Alternative Conception Research Programme*. *Sci. Ed.*, 69, (5), 681-696.
- Gilbert, J., Osborne, R. & Fenham, P. (1982) *Children's Science and its Consequences for Science Teaching*. *Sci. Ed.*, 66, (4), 623-633.
- Hann, K., Brosnan, T. & Ogborn, J. (1991). *CHATS "Children and Teachers Talking Science": work in progress*. A paper presented at the 16th International ATEE (Association for Teacher Education in Europe) Conference, The Netherlands, September 1991.
- Harré, R. (1985). *The Philosophies of Science: an Introductory Survey*. Oxford: Oxford University Press.
- Harré, R. (1986). *Varieties of Realism: a Rationale for the Natural Sciences*. Oxford: Blackwell.
- Helm, H. (1980). *Misconceptions in Physics amongst South African Students*. *Phys. Ed.*, 15, 92-97.
- Hesse, M. (1963) *Models and Analogies in Science*. London: Sheed & Ward Ltd.
- Hewson, P. (1981). *A Conceptual Approach to Learning Science*. *Eur. J. Sci. Ed.*, 3, (4), 383-396.



- Inhelder, B., de Caprona, D & Corm-Wells, A. (1987). *Piaget Today*. London: LEA.
- Johnson-Laird, P. (1983). *Mental Models*. Cambridge: Cambridge University Press.
- Johnson-Laird, P. (1984). *Only Connections: a critique of semantic networks*. Phys. Bul., vol. 96, No.: 2, 292-315.
- Kelly, G. (1955). *The Psychology of Personal Constructs*. vols. 1 and 2. New York: Norton.
- Klaassen, K., Eijkelhof, H. & Lijnse, P. (1989). *Considering an Alternative Approach to Teaching Radioactivity*. Paper presented at the seminar 'Relating Macroscopic Phenomena to Microscopic Particles: A Central Problem in Science Education', University of Utrecht, The Netherlands.
- Kubli, F. (1979). *Piaget's Cognitive Psychology and its Consequences for the Teaching of Science*. Eur. J. Sci. Ed., vol.1, No.:1, 5-20.
- Lakoff, G. & Johnson, M. (1980) *Metaphors we Live By*. Chicago: The University of Chicago Press.
- Layton, D. (1988). *Revaluating the T in STS*. Int. J. Sci. Ed., vol.10, No.: 4, 367-378.
- Layton, D., Davey, A. & Jenkins, E. (1986). *Science for Specific Social purposes (SSSP): perspectives on adult scientific literacy*. Stud. Sci.Ed., 13, 27-52.
- Lucas, A. (1988). *Public Knowledge of Elementary Physics*. Phys.Ed., 23, 10-16.
- Mariani, M. C. & Ogborn, J. (1991). *Towards an Ontology of Commonsense Reasoning*. Int. J. Sci. Ed., vol.13, No.: 1, 69-86.
- McCloskey, M. (1983). *Naive Theories of Motion*. in Gentner, D. & Stevens, A. (eds) (1983). *Mental Models*. London: Lawrence Earlbaum Associates Publishers.

- McConnell, M. (1982). *Teaching about Science, Technology and Society at the Secondary Schooling the United States. An Educational Dilemma for the 1980s*. Stud. Sci. Ed., 9, 1-32.
- Miller, J. (1983a). *Scientific Literacy: a conceptual review*. Daedalus 112 (2): 19-48.
- Miller, J. (1983b). *The American Public and Science Policy*. New York: Pergamon.
- Miller, J. (1986). *Technological Literacy: some concepts and measures*. Paper presented at the National Technological Literacy Conference, Baltimore, February, 1986.
- Minsky, M. (1975). *Frame Theory*. in Schank, R. & NashWebber, L. (eds.) (1975). Theoretical Issues in Natural Language Processing. Pre-prints of a conference at MIT (reprinted in Jonhson-Laird, P. & Wason, Thinking: Readings in Cognitive Science. Cambridge: Cambridge University Press.
- National Science Board (1985). *Science Indicators*. Government Printing Office: Washington DC.
- Needham, R. et al (1987). *Teaching Strategies for Developing Understanding of Science*. CLIS Project, Centre for Science and Mathematics education, University of Leeds.
- Norman, D. & Rumelhart, D. (1985) *Representation of Knowledge*. in Aitkenhead, A. & Slack, J. (1985) Issues in Cognitive Modelling, London: Lawrence Earlbaum Associates Publishers.
- Norman, D. (1983) *Some Observations on Mental Models*. in Gentner, D. & Stevens, A. (eds) (1983). Mental Models. London: Lawrence Earlbaum Associates Publishers.
- Nussbaum, J. & Novak, J. (1976). *An Assesment of Children's Concepts of the Earth using Structured Interviews*. Sci. Ed., 60, (4), 535-550.

## BIBLIOGRAPHY

---

- Ogborn, J. (1985) *Understanding Students' Understandings: an example from dynamics*. Int. J. Sci. ed. vol.7, No.: 2, 141-150.
- Ogborn, J. (1987). *The Nature of Science and the Implications for Science for All*. pre-print, Institute of Education, University of London.
- Ogborn, J. (1989). *Primitive structures of commonsense reasoning and the understanding of science*. paper presented at the ANTHENA Conference, Montpellier, France.
- Ogborn, J. (1989). *Modelling with the Computer: prospects and possibilities*. Pre-print, Institute of Education, University of London.
- Osborne, R. & Wittrock, M. (1983). *Learning Science: A Generative Learning Process*. Sci. Ed., 67, (4), 489-508.
- Osgood, C., Suci, G. & Tannebaum, P. (1957) *The Measurement of Meaning*. Chicago: University of Illinois Press.
- Piaget, J. (1929) *The Child's Conception of Physical Causality*. London: Routledge & Kegan Paul.
- Piaget, J & Inhelder, B. (1973). *Memory and Intelligence*. London: Routledge & Kegan Paul.
- Pope, M. & Gilbert, J. (1983). *Personal experience and the Construction of Knowledge in Science*. Sci. Ed., 67, 2, 173-203.
- Proverbio, E. & Lai, S. (1989). *Spontaneous Models and the Formalisation of the Concepts of Weather and Time at the Elementary School Level*. Int. J. Sci. Ed., vol.11, No.: 1, 113-123.
- Ronen, M. & Ganiel, U. (1988). *From Assumptions of Knowledge to Knowledgeable Considerations: a class activity on ionising radiation and its biological effects*. Int. J. sci. Ed., vol. 10, No.5.

- Schank, R. & Abelson, P. (1977). *Scripts, Plans, Goals and Understandings*. London: Lawrence Earlbaum Associates Publishers.
- Schank, R. (1986). *Explanation Patterns. Understanding Mechanically and Creatively*. London: Lawrence Earlbaum Associates Publishers.
- Schutz, A. & Luckmann, T. (1974). *The Structures of the Life-World*. London: Heinemann.
- Scott, P. et al (1987). *A Constructivist View of Learning and Teaching Science*. CLIS Project, Centre for Science and Mathematics education, University of Leeds.
- Séré, M. G. (1985). *The Gaseous State*. in Driver, R., Guesne, E. & Tiberghien, A. (1985). *Children's Ideas in Science*. Milton Keynes: Open University Press.
- Séré, M. G. (1986). *Children's Conceptions of the Gaseous State, prior to teaching*. Eur. J. Sci. Ed., 8, 413-425.
- Shayer, M. & Adey, P. (1981). *Towards a Science of Science Teaching*. London: Heinemann.
- Shortland, M. & Gregory, J. (1991). *Communicating Science*. London: Longman Science and Technology.
- Shuell, T. (1987). *Cognitive Psychology and Conceptual Change: implications for teaching science*. , Sci. Ed., 71, (2): 239-250.
- Solomon, J. (1983) *Learning about Energy: how people think in two domains*. Eur. J. Sci. Ed., vol.5, No.: 1, 49-59.
- Solomon, J. (1986) *Social Influences on the Construction of Pupils' Understandings of Science*. Stud. Sci. Ed., 14, 63-82.
- Solomon, J. (1987) *Social influences on the Construction of Pupils' Understandings of Science*. Stud. Sci. Ed., 14, 63-82

- Solomon, J. (1988). *Science Technology and Society courses: tools for thinking about social issues*. Int. J. Sci. Ed., vol.10, No.: 4, 379-387.
- Stewart, J. (1980). *Techniques for Assessing and Reporting Information in Cognitive Structure*. Sci. Ed., 64, (2), 223-235.
- The Royal Society (1985). *The Public Understanding of Science*. London: The Royal Society.
- van Dijk, T. & Kintsch, W. (1983). *Strategies of Discourse Comprehension*. New York: Academic Press.
- Viennot, L. (1979). *Spontaneous Reasoning in Elementary Dynamics*. Eur. J. Sci. Ed., vol.7, (2), 151-162.
- Vosniadou, S. & Ortony, A. (1989). *Similarity and Analogical Reasoning*. Cambridge: Cambridge University Press.
- Wandersee, J. (1985). *Can the history of science help science educators to anticipate students' misconceptions?*. J. Res. Sci. Teach., 23, 7, 581-597.
- Whitelock, D. (1990). *Commonsense Causes of Motion*. Unpublished PhD thesis, Institute of Education, University of London.
- Williams, M., Hollan, J. & Stevens, A. (1983). *Human Reasoning about a Simple Physical System*. in Gentner, D. & Stevens, A. (eds) (1983). *Mental Models*. London: Lawrence Earlbaum Associates Publishers.
- Wiser, M & Caery, S. (1983) *When Heat and Temperature Were One*. in Gentner, D. & Stevens, A. (eds) (1983). *Mental Models*. London: Lawrence Earlbaum Associates Publishers.
- Ziman, J. (1978) *Reliable Knowledge*. Cambridge: Cambridge University Press.
- Ziman, J. (1984). *An Introduction to Science Studies*. Cambridge: Cambridge University Press.

## BIBLIOGRAPHY

---

Ziman, J. (1990). *"Its not what you do: it's the way you do it!"*. *The Rationale of STS Education is in the Approach*. paper presented at the British Council's "Science Technology and Society Education" course, Department of Educational Studies, University of Oxford, September 10-20, 1990.

Zoller, U., Donn, S., Wild, R. & Beckett, P. (1991). *Students' versus their teachers' beliefs and positions on science/Technology /Society- Oriented Issues*. *Int. J. Sci. Ed.*, vol.13, No.: 1, 25-36.

**APPENDIX 4.1**

**WRITTEN TEXTS ANALYSED**

**NEWSPAPER AND WEEKLY MAGAZINE MATERIALS**

Correio Braziliense, 29.09.87

Folha de São Paulo, 15.10.87

Folha de São Paulo, 16.10.87

Folha de São Paulo, 19.11.87

Isto é, 04.11.87

Isto é, 08.11.87

Jornal do Brasil, 01.07.91

Jornal do Brasil, 01.10.87

Jornal do Brasil, 01.11.87

Jornal do Brasil, 11.10.87

Jornal do Brasil, 11.10.87

Jornal do Brasil, 12.03.88

Jornal do Brasil, 12.03.89

Jornal do Brasil, 12.11.87

Jornal do Brasil, 18.02.90

Jornal do Brasil, 23.10.87

Jornal do Brasil, 25.08.89

Jornal do Brasil, 29.04.88

O Estado de São Paulo, 08.11.87

O Globo, 01.11.87

O Globo, 11.10.87

O Globo, 13.10.87

O Globo, 24.10.87

O Globo, 20.06.89

O País, 29.10.87

Time, (1987). *A Battle Against Deadly Dust.*, pp.46-47.

Veja, 14.10.87



Veja, 28.10.87

### SCIENTIFIC POPULARISATION MAGAZINES

Ciência Hoje, vol.1, No.: 4, 1983 “Radiação ambiental na região de Poços de Caldas”.

Ciência Hoje, vol.2, No.: 12, 1984 “Os males dos raios-X dentários”.

Ciência Hoje, vol.2, No.: 12, 1984. “Raios-X”.

Ciência Hoje, vol.4, No.: 24, 1986. “O que aconteceu em Tchernobyl?”.

Ciência Hoje, vol.5, No.: 28, 1987 “Radiação ao alcance de todos”.

Ciência Hoje, vol.7, No.:40, 1988, Supplement “Autos de Goiânia”

New Scientist (1986). *Tracking the cloud from Chernobyl*’. 17.07.86, 42-45.

New Scientist (1987). “*Lessons from the Soviets*” . 23.04.87, 37-39.

New Scientist (1987). *May sheep safely graze?* 23.04.87, 46-49.

New Scientist (1987). *Nuclear medicine homes in on disease.*, 15.01.87, 48-53.

New Scientist (1987). *Radiation meets the public’s taste.* , 19.02.87, 46-49.

New Scientist, (1987). *Europe calculates the risk.* 23.04.87, 40-43.

Which? (1989). *Irradiation.* Nov., 541-543.

### TEACHERS’ SUPPORT MATERIALS

Cruz, F. (1987) *Radioatividade e o acidente de Goiânia.* Caderno Catarinense de Ensino de Física, vol.4, No.: 3, dec.

ICChemE 2 Science in Action, *Food Irradiation.*

Okuno, E. (1989). *Radiação: Efeitos, Riscos e Benefícios.* São Paulo: Harbra.

SATIS

SISCON

Terrazan, E. (1989). *Radiações*. Revista de Ensino de Ciências, No.: 22, 8-16.

**EXPLANATORY LEAFLETS**

IAEA, "*How Concerned should we be about Low-level Radiation*" - a companion leaflet to *Radiation - a fact of life*.

Friends of the Earth (1989) *Irradiation: the contamination of food*.

MAFF, (1989). News Releases: McLean Questions Food Irradiation Fiction., 21.06.89

UKAEA, Radiation and You.

UKAEA, Nuclear Fusion.

UKAEA, Nuclear Waste.

UKAEA, Atoms at Work.

UKAEA, Energy and the Need for Nuclear Power.

UKAEA, The Effects and Control of Radiation.

UKAEA, A Glossary of Atomic Terms.

**APPENDIX 5.1**

**ARTICLE USED IN INTERVIEWS**

**"Contamination of Distant Objects"**

## Surgem novos focos de alta radiação

Um novo foco de contaminação por césio-137 em Goiânia, fora da área isolada, foi encontrado por físicos goianos. Luiz Pinguelli Rosa, Diretor da Coordenação dos Programas de Pós-Graduação em Engenharia da UFRJ e Membro da Sociedade Brasileira de Física, disse que duas árvores — uma a 60 metros e outra a 100 metros do ferro-velho de Devair Alves Ferreira, onde a cápsula de césio foi quebrada — apresentaram níveis de radiação 20 vezes superior àquele permitido pela Cnen na ocasião da importação de leite contaminado em Tchernóbyl.

Os frutos da mangueira e da banana apresentaram níveis de contaminação equivalente a 8 mil becquerel (unidade de radiação) por quilo e que as folhas das árvores apresentaram cerca de 24 mil. Segundo Pinguelli, o nível de contaminação dos alimentos permitido pela Cnen é de 370 BQ por quilo, considerado bastante alto para se permitir que sejam consumidos.

O físico explicou que a possibilidade de existirem outros focos ainda não identificados é muito remota, mas deveria ser feita uma monitoração nas demais áreas, pois com as chuvas fortes a penetração do césio-137 no solo é favorecida por ele estar em forma de cloreto e a contaminação pode se dar mais rapidamente, como foi o caso das árvores que estavam bem próximas da Rua 57.

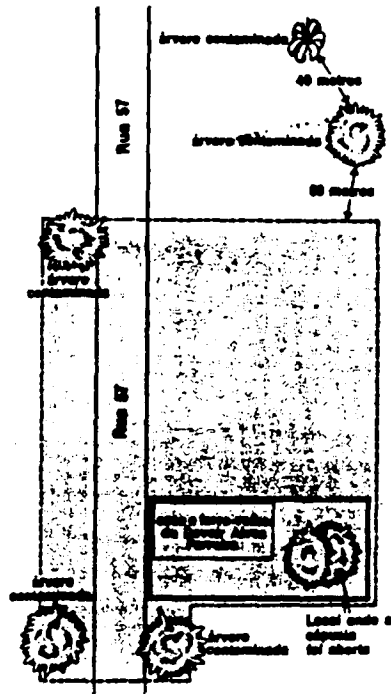

Os focos estão fora da área isolada

A descoberta foi comunicada à Cnen, mas, segundo Pinguelli, nada foi feito para esclarecer à população o que a ingestão dos frutos pode causar, embora seja grande a probabilidade de se contrair doenças, como o câncer.

JB, 12.11.87

**APPENDIX 5.2**

**ARTICLE USED IN INTERVIEWS**

**"Can We Keep it Safe?"**

O G L O B O  
2 0 JUN 1989  
PESQUISA

O MUNDO/CIENCIA E VIDA • 15

O G L O B O

Terça-feira, 20 de junho de 1989

# Césio mal armazenado ameaça Goiânia

**SÃO PAULO** — O Instituto de Pesquisas Energéticas e Nucleares (Ipen) concluiu ontem um estudo, a pedido da Comissão Nacional de Energia Nuclear (Cnen), no qual recomendou a construção de um depósito definitivo para o lixo radioativo de Goiânia, período durante o qual se com o césio. O estudo conclui que, na época, a lixo foi armazenado inadequadamente, o que representa uma séria ameaça de contaminação à população.

Segundo o Chefe do Departamento de Ciclo de Combustível do Ipen, Achilles Afonso Suarez — responsável pelo estudo —, o lixo radioativo não é liberado como esturro e misturado com o lixo comum, sob condições adversas como calor e umidade. Também não foi possível deixar de conter a terra em torno de um depósito de dentro para fora dos recipientes, aumentando o risco de ocorrer uma eventual liberação de material radioativo para o meio ambiente.

Suarez ressaltou que os próprios trabalhadores também foram contaminados durante o armazenamento de lixo radioativo, sofrendo graves consequências para a saúde.

## O projeto do depósito

O depósito, revestido de concreto e com capacidade de armazenar 3.000 cúbicos de resíduos radioativos, terá 30 por 50 metros e uma altura de 10 metros. O custo de construção é de cerca de R\$23,5 milhões.

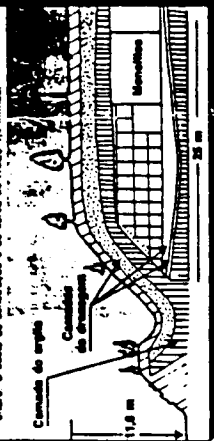

projetam um processo de correção, de modo a evitar a liberação de material radioativo para o meio ambiente. No entanto, Suarez explicou que, devido ao tamanho das células de armazenamento, o depósito não poderá ser construído em um único bloco, mas sim em várias células, o que permitirá a construção de um depósito de concreto armado, mas sem colunas, de forma a evitar a liberação de material radioativo para o meio ambiente.

O local do depósito de lixo radioativo foi escolhido em uma área de 10 hectares, onde há um depósito de concreto armado, mas sem colunas, de forma a evitar a liberação de material radioativo para o meio ambiente.

## Projeto serve também para resíduos de Angra

O modelo de depósito de lixo radioativo também serve para resíduos de Angra. O projeto foi desenvolvido pelo Instituto de Pesquisas Energéticas e Nucleares (Ipen), sob a supervisão da Comissão Nacional de Energia Nuclear (Cnen). O estudo conclui que o depósito de resíduos de Angra deve ser construído em uma área de 10 hectares, onde há um depósito de concreto armado, mas sem colunas, de forma a evitar a liberação de material radioativo para o meio ambiente.

A ideia é colocar os tanques e o concreto armado sobre pilares, evitando-se completamente. Ao lado, há um compartimento para o armazenamento de lixo radioativo. Esse modelo utiliza ainda a argila como revestimento dos compartimentos, já que ela também funciona como isolante de radioatividade.

Um modelo de depósito brasileiro de lixo radioativo também serve para resíduos de Angra. O projeto foi desenvolvido pelo Instituto de Pesquisas Energéticas e Nucleares (Ipen), sob a supervisão da Comissão Nacional de Energia Nuclear (Cnen). O estudo conclui que o depósito de resíduos de Angra deve ser construído em uma área de 10 hectares, onde há um depósito de concreto armado, mas sem colunas, de forma a evitar a liberação de material radioativo para o meio ambiente.

Um modelo de depósito brasileiro de lixo radioativo também serve para resíduos de Angra. O projeto foi desenvolvido pelo Instituto de Pesquisas Energéticas e Nucleares (Ipen), sob a supervisão da Comissão Nacional de Energia Nuclear (Cnen). O estudo conclui que o depósito de resíduos de Angra deve ser construído em uma área de 10 hectares, onde há um depósito de concreto armado, mas sem colunas, de forma a evitar a liberação de material radioativo para o meio ambiente.

**APPENDIX 5.3**

**TEXT USED IN INTERVIEWS**

JB, 23.10.87

## Radiação dura três séculos

*Em 2300, lixo atômico ainda emitirá 1 curie*

**A** radiatividade é o processo em que certos núcleos de átomos sofrem desintegração, liberando energia e formando, em geral, novos átomos. Nesse processo, costuma haver emissão de um ou mais tipos de radiação: as partículas alfa e beta e os raios gama.

As partículas alfa têm pouco poder de penetração e podem ser detidas por uma simples folha de papel. Vale dizer, uma pessoa submetida a radiação alfa sofre danos apenas na pele.

As partículas beta são um pouco mais penetrantes que as partículas alfa. São capazes de atravessar uma folha de papel, mas não atravessam, por exemplo, uma lâmina fina de metal leve, como o alumínio. Numa pessoa submetida a radiação beta, os danos vão um pouco além da pele, mas também não são profundos, a não ser que a pessoa tenha inalado ou ingerido uma substância emissora de radiação beta. Nesse caso, as partículas provocarão danos maiores, pois estarão sendo emitidas dentro do corpo. Foi o que aconteceu com a menina Leide das Neves Ferreira, que ingeriu o césio 137 com um ovo cozido. O césio 137 emite partículas beta ao se desintegrar.

Os raios gama são muito mais pene-

trantes. São não conseguem atravessar camadas espessas de chumbo (por isso, a blindagem com chumbo nos caixões das vítimas de Goiânia). Assim, uma pessoa submetida por tempo prolongado a radiação gama sofre danos nos tecidos profundos de seu corpo. Ao se desintegrar, o césio 137 transforma-se em bário 137, que é emissor de raios gama. Por isso, as vítimas de Goiânia foram expostas aos dois tipos de radiação — beta e gama.

Quando a radiação atravessa um material qualquer, ela modifica os átomos desse material. A essa modificação chama-se ionização, isto é, a radiação tira elétrons dos átomos, mudando as características das moléculas constituídas por esses átomos (há aplicações industriais em que a radiação é propositalmente usada para mudar um determinado material, tornando-o por exemplo, mais duro ou mais flexível).

Quando a radiação passa por um tecido vivo, ela também ioniza seus átomos.

A consequência é que as células que formam esse tecido ou são destruídas ou passam a se reproduzir de maneira diferente do normal. É por isso aliás, que a radiação tanto serve para tratar o câncer, como pode ser causadora de câncer. Aplicada com cuidado, em doses cientificamente calculadas, por um tempo também calculado, e dirigida especificamente para o órgão que se quer tratar, a radiação mata as células cancerosas. Aplicada sem con-

trole pode transformar células sadias em células cancerosas. A incidência de câncer é, porém, uma probabilidade estatística, como revela o médico Luis Renato Caldas, chefe do Serviço de Radiologia do Hospital dos Servidores do Estado. Não é garantido que uma pessoa irradiada vai ter câncer, apenas a probabilidade é maior.

A radiatividade é medida em curies, em homenagem à pesquisadora franco-polonesa Marie Curie, que estudou e esclareceu seus mecanismos, tendo descoberto no começo do século o elemento rádio, e que morreu de câncer. Como explica o físico Aquilino Senra Martinez, da Coppe/UFRJ, um curie equivale a  $3,7 \times 10^{10}$  desintegrações por segundo. Isto quer dizer que um curie equivale à radiação emitida pela desintegração de 37 bilhões de átomos por segundo. A CNEN (Comissão Nacional de Energia Nuclear) informa que a bomba de césio destruída em Goiânia tinha uma atividade total, em 1971, quando foi fabricada, de 2.000 curies. Ou seja, naquela ocasião, 74 bilhões de átomos de césio desintegravam-se (e, portanto, emitiam radiação) a cada segundo. Quando o átomo de césio se desintegra, vira átomo de bário. Por isso, no mês passado, quando a bomba foi destruída, havia em seu interior átomos de bário do que em 1971 (a CNEN calcula que em setembro a atividade da bomba já tinha caído para 1.370 curies, isto é, 50 trilhões 690 bilhões de átomos de césio desintegrando-se por segundo).



**APPENDIX 6.1**

**THE PILOT QUESTIONNAIRE**

2

1ª Parte

1- Descreva brevemente o acidente com material radioativo em Goiânia:

Em 13 de setembro de 1987, ocorreu um acidente com material radioativo em Goiânia, quando um técnico de uma empresa de manutenção de equipamentos elétricos, ao trabalhar em um equipamento de diagnóstico por imagem, utilizou um equipamento de diagnóstico por imagem que continha uma fonte de radiação radioativa, resultando na contaminação de uma pessoa e na liberação de material radioativo no ambiente.

2- Quanto certeza você tem de se lembrar do que aconteceu?

- total
- muito
- alguma
- pouco
- nenhuma

3- Quantas pessoas morreram neste acidente?

- nenhuma
- de 1 a 5
- de 5 a 10
- de 10 a 20
- mais de 20
- não sei

4- Quanto tempo demorou, depois de ter sabido do acidente, para que você pudesse avaliar a gravidade da situação?

- 1 dia
- 3 dias
- 1 semana
- 1 mês
- mais de 1 mês
- não lembro

5- Após você ouviu falar do acidente primeiro?

- TV
- rádio
- revista
- jornal
- escola
- trabalho
- amigos
- outro, qual? \_\_\_\_\_

Nome: GILANK Data: 16/1/87  
 Escola: 3ª de 2ª G Série Escolar: 3ª de 2ª G

O objetivo deste questionário é conhecer melhor o que as pessoas entendem por radiação e por radioatividade.

Grande parte da informação que você possui acerca de radiação foi provavelmente adquirida através dos meios de comunicação por ocasião do acidente envolvendo material radioativo em Goiânia em 1987.

Por esta razão, a primeira parte deste questionário se compõe de perguntas sobre o que você se lembra e sobre o que você entendeu acerca do que foi dito, escrito ou falado a respeito de radioatividade na época do acidente.

Na segunda parte, existem perguntas mais específicas sobre tópicos tais como: a natureza da radiação, como se dá a contaminação radioativa, etc.

Lembre-se que este não é um teste de conhecimento e que não vale nota. Responda as perguntas com atenção e não se preocupe com certo ou errado. Estamos interessados em qualquer resposta que você possa dar. Muito obrigada por sua colaboração.

6 - Você sabe alguma coisa sobre radioatividade antes do acidente?

- sim
- não

Se sua resposta for sim, vá para questão 7  
 Se sua resposta for não, vá para questão 2

7 - Aonde você obteve estas informações? (se for o caso, você pode marcar mais de uma alternativa neste questionário)

- casa
- escola
- revista
- jornal
- livros
- TV
- rádio
- outro, qual? \_\_\_\_\_

8 - Este conhecimento que você já possuiu foi suficiente para você entender os comentários feitos sobre radiação ou radioatividade?

- inteiramente
- até certo ponto
- só um pouco
- de jeito nenhum

9 - Você procurou alguma informação sobre radioatividade depois do acidente?

- sim
- não

Se sua resposta for sim, vá para questão 10  
 Se sua resposta for não, vá para questão 13

10 - Aonde ou com quem você procurou estas informações? (se for o caso, você pode marcar mais de uma alternativa neste questionário)

- casa
- escola
- revista
- livros
- TV
- rádio
- país
- professor
- amigo
- outro, qual? \_\_\_\_\_

4

11 - Aonde ou com quem você encontrou estas informações? (se for o caso, você pode marcar mais de uma alternativa neste questionário)

- casa
- escola
- revista
- livros
- TV
- rádio
- país
- professor
- amigo
- outro, qual? \_\_\_\_\_

12 - Qual foi o razão para procurar estas informações ou conversar com estas pessoas?

- tornar seus hábitos sobre radiação ou radioatividade mais claras
- obter uma explicação sobre radiação ou radioatividade
- simplesmente aprender alguma coisa nova
- entender melhor os fatos relacionados à contaminação
- mera curiosidade
- outra, qual? \_\_\_\_\_

13 - Quem, na sua opinião, deve entender de radiação e radioatividade? (se for o caso, você pode marcar mais de uma alternativa neste questionário)

- país
- professor
- jornalista
- amigo
- engenheiro
- outro, quem? todos da comunidade em geral menos uma ou duas pessoas
- médico
- cientista
- político
- todo mundo, em princípio
- ninguém

14 - Quem, na sua opinião, realmente entende de radioatividade? (se for o caso, você pode marcar mais de uma alternativa neste questionário)

- país
- professor
- jornalista
- amigo
- engenheiro
- outro, quem? ninguém
- médico
- cientista
- político
- todo mundo, em princípio
- ninguém

5

15- As informações que você obteve sobre radioatividade, na época do acidente, se relacionavam principalmente com:  
 uma análise dos possíveis causas do acidente  
 comparações com outros acidentes envolvendo radiação  
 descrição das medidas de controle e segurança tomadas  
 possíveis consequências da exposição à radiação  
 explicações acerca da natureza da radioatividade  
 não obteve nenhuma informação  
 outra, qual? \_\_\_\_\_

16- Existem coisas que você não tenha entendido na época?

sim  
 não

Se sua resposta for sim, vá para questão 17

Se sua resposta for não, vá para questão 18

17- As coisas que você não entendeu se relacionavam principalmente com:

informações científicas a respeito da natureza da radioatividade  
 informações médicas acerca dos efeitos da exposição à radiação  
 causas do acidente  
 medidas de segurança e controle necessárias  
 outras, qual? \_\_\_\_\_

18- Que tipo de informação foi mais útil e mais lhe ajudou a entender alguma coisa sobre radiação ou radioatividade?

informações científicas a respeito da natureza da radioatividade  
 informações médicas acerca dos efeitos da exposição à radiação  
 causas do acidente  
 medidas de segurança e controle necessárias  
 outras, qual? \_\_\_\_\_

19- Que tipo de informação lhe ajudou a entender alguma coisa sobre radioatividade?

informações científicas a respeito da natureza da radioatividade  
 informações médicas acerca dos efeitos da exposição à radiação  
 causas do acidente  
 medidas de segurança e controle necessárias  
 outras, qual? \_\_\_\_\_

6

20- Existem coisas que você ainda não entende?

sim  
 não

Se sua resposta for sim, vá para questão 21

Se sua resposta for não, vá para questão 22

21- As coisas que você ainda não entende se relacionam principalmente a:  
 informações científicas a respeito da natureza da radioatividade  
 informações médicas acerca dos efeitos da exposição à radiação  
 causas do acidente  
 medidas de segurança e controle necessárias  
 outras, qual? \_\_\_\_\_

22- Você se sentiu capaz de, na época, avaliar os riscos envolvidos na situação?  sim  não

Por que? Porque obtive uma boa educação para isso

Devido ao fato de

2ª Parte

1 - Na sua opinião a RADIOATIVIDADE se parece de alguma forma com:  
(nesta questão você pode, se quiser, assinalar mais de uma opção)

- o ar
- a luz
- raios-X
- campo magnético
- a água
- ondas de rádio
- um gás
- um objeto
- uma nuvem
- a eletricidade
- poeira
- raios

2 - Nesta questão apresentamos uma sequência de pares de afirmativas a respeito de radiação ou radioatividade. Indique sua resposta com um X, procedendo da seguinte forma:

assinale esta alternativa se você considerar a afirmativa da esquerda perfeitamente adequada ao se falar de radiação ou radioatividade

assinale esta alternativa se você considerar a afirmativa da direita perfeitamente adequada ao se falar de radiação ou radioatividade

assinale esta alternativa se você considerar a afirmativa da esquerda parcialmente adequada ao se falar de radiação ou radioatividade

assinale esta afirmativa se você considerar a afirmativa da direita parcialmente adequada ao se falar de radiação ou radioatividade

assinale esta alternativa se você considerar que ambas são igualmente adequadas ao se falar de radiação ou radioatividade

Você acha que Radiação / Radioatividade:

duro para sempre	<input checked="" type="checkbox"/> <input type="checkbox"/> <input type="checkbox"/> <input type="checkbox"/>	ocorre com o tempo
existe na natureza	<input type="checkbox"/> <input checked="" type="checkbox"/> <input type="checkbox"/> <input type="checkbox"/>	é fabricada artificialmente
pode ser absorvida	<input checked="" type="checkbox"/> <input type="checkbox"/> <input type="checkbox"/> <input type="checkbox"/>	é bloqueada por alguns objetos
aumenta por si só	<input type="checkbox"/> <input type="checkbox"/> <input checked="" type="checkbox"/> <input type="checkbox"/>	pode ser refletida
pode ser dividida em partes	<input type="checkbox"/> <input type="checkbox"/> <input type="checkbox"/> <input type="checkbox"/>	tem que ser feita por um processo especial
é estática	<input type="checkbox"/> <input checked="" type="checkbox"/> <input type="checkbox"/> <input type="checkbox"/>	não pode ser dividida em partes
não é material	<input type="checkbox"/> <input type="checkbox"/> <input checked="" type="checkbox"/> <input type="checkbox"/>	se move
pode ser localizada no espaço	<input type="checkbox"/> <input checked="" type="checkbox"/> <input type="checkbox"/> <input type="checkbox"/>	é material

Vire a página para encontrar as afirmativas a respeito de radiação ou radioatividade, analise-as com atenção e indique suas repostas conforme foi especificado acima.

3.1 - A radiação é utilizada para esterilizar alimentos.

Já ouviu falar?	sim	não
entende como pode ser?	<input type="checkbox"/>	<input checked="" type="checkbox"/>
sabe explicar?	<input type="checkbox"/>	<input checked="" type="checkbox"/>
gostaria de uma explicação?	<input checked="" type="checkbox"/>	<input type="checkbox"/>

3.2 - A luz emitida pelo sol é um exemplo de radiação.

Já ouviu falar?	sim	não
entende como pode ser?	<input checked="" type="checkbox"/>	<input type="checkbox"/>
sabe explicar?	<input checked="" type="checkbox"/>	<input type="checkbox"/>
gostaria de uma explicação?	<input checked="" type="checkbox"/>	<input type="checkbox"/>

3.3 - A radiação é utilizada no tratamento de doenças como o cancro.

Já ouviu falar?	sim	não
entende como pode ser?	<input checked="" type="checkbox"/>	<input type="checkbox"/>
sabe explicar?	<input checked="" type="checkbox"/>	<input type="checkbox"/>
gostaria de uma explicação?	<input checked="" type="checkbox"/>	<input type="checkbox"/>

3.4 - Existem lugares, como Quarcuarl, onde existe um alto nível de radiação do meio ambiente.

Já ouviu falar?	sim	não
entende como pode ser?	<input checked="" type="checkbox"/>	<input type="checkbox"/>
sabe explicar?	<input checked="" type="checkbox"/>	<input type="checkbox"/>
gostaria de uma explicação?	<input checked="" type="checkbox"/>	<input type="checkbox"/>

*Eu realmente gostaria de obter um formulário sobre*

é composto de partículas	<input checked="" type="checkbox"/>	não é composto de partículas
age sobre os corpos ao seu redor	<input checked="" type="checkbox"/>	não age sobre os corpos ao seu redor
atua diretamente por contato	<input checked="" type="checkbox"/>	não atua diretamente por contato
não atua à distância	<input checked="" type="checkbox"/>	atua à distância
não é afetada por corpos ao seu redor	<input checked="" type="checkbox"/>	é afetada por corpos ao seu redor
cria coisas	<input checked="" type="checkbox"/>	destrói coisas
age por si só	<input checked="" type="checkbox"/>	é colocada em ação por alguma outra coisa
é criada do nada	<input checked="" type="checkbox"/>	é gerada por alguma coisa
não pode ser guardada em segurança	<input type="checkbox"/>	pode ser guardada em segurança
pode tornar outros corpos radioativos	<input checked="" type="checkbox"/>	não pode tornar outros corpos radioativos
é algo complicado de se entender	<input checked="" type="checkbox"/>	é algo simples de se entender

**APPENDIX 6.2**

**CALCULATION OF**

**$\sigma$  max**

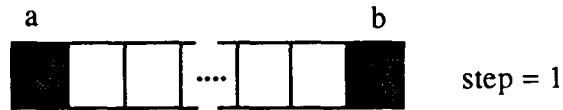

In the above scale, for any mean, the maximum standard deviation is when all replies are a or b. In this case, for a total of N responses, if f is the fraction of 'b' choices, then the fraction of 'a' responses must be (1-f). In this case of maximum dispersion, the mean is:

$$M = \frac{1}{N} [f N b + (1-f) N a]$$

and:

$$f = \frac{M - a}{b - a}$$

The square of the maximum standard deviation is:

$$\sigma_{\max}^2 = \frac{1}{N} [f N (b - M)^2 + (1-f) N (a - M)^2]$$

Substituting for f in terms of M, a and b, the expression is reduced to:

$$\sigma_{\max}^2 = (b - M)(M - a)$$

For a=1, b=5:

$$\sigma_{\max} = \sqrt{(5 - M)(M - 1)}$$



**APPENDIX 7.1**

**STUDENTS' QUESTIONNAIRE**

1  
 07/1910 R20 R45- 6

-1-

Nome: \_\_\_\_\_ Ocupação: ESTUDANTE Idade: 17 Série Escolar: 3ª

*O objetivo deste questionário é conhecer e entender melhor o que as pessoas entendem por radioatividade. Leia com atenção as instruções e responda as perguntas sem se preocupar com certo e errado. Este questionário não é um teste escolar e, portanto, não vale nota. Muito obrigada pela sua colaboração.*

1- Nesta questão apresentamos uma lista relacionando conceitos em física, objetos da experiência diária, elementos da natureza, etc. Pedimos que você leia esta lista com atenção e pense se a radioatividade pode ser vista, pensada ou entendida como alguma opções propostas. Você deve indicar suas respostas marcando um X nas lacunas correspondentes a SIM ou NÃO para cada item.

Você acha que a RADIOATIVIDADE, de alguma forma, se parece com:

	SIM	NÃO
o ar	X	
ondas	X	
uma nuvem		X
raios	X	
neve		X
água	X	
raios-X	X	
um campo magnético	X	
eletricidade		X
calor		X
um objeto		X
luz	X	
energia	X	
som		X
movimento	X	
um gás		X
fumaça		X

2- Nesta questão nós gostaríamos que você avaliasse o conceito de radioatividade em relação a uma série de escalas que estão divididas em cinco intervalos e que contêm em seus extremos dois adjetivos que são complementares em significado. Leia as instruções com atenção e responda a cada um dos itens separadamente sem tentar checar itens que lhe pareçam similares. Faça seu julgamento baseado no que o conceito de radioatividade significa para você tendo cuidado para não "pular" nenhum item. Proceda da seguinte forma:

Marque esta posição se você considerar o adjetivo da esquerda PERFEITAMENTE adequado para se referir à radioatividade.

Marque esta posição se você considerar o adjetivo da direita PERFEITAMENTE adequado para se referir à radioatividade.

Marque esta posição se você considerar o adjetivo da esquerda PARCIALMENTE adequado para se referir à radioatividade.

Marque esta posição se você considerar o adjetivo da direita PARCIALMENTE adequado para se referir à radioatividade.

Marque esta posição se você considerar que ambos adjetivos são IGUALMENTE adequados para se referir à radioatividade.

Vire e pegine para responder as perguntas da questão 2.

-2-

Pense em RADIOATIVIDADE

Você acha que ele é:

material				X	imaterial
momentânea				X	eterna
complexa		X			simples
forte					fraca
ampla	X				tem forma
efêmera					duradoura
comum	X				especial
passiva					ativa
solida					fluida
está sempre ali		X			que vai e volta
natural			X		artificial
energética			X		inerte
espalhada			X		localizada
irrequente				X	rara
destruidora			X		criadora
tem que ser fabricada			X		crece por si só
leve	X				pesada
estável			X		instável
prejudicial			X		benéfica
poterosa	X				impotente
não é composta de partículas					é composta de partículas
imóvel				X	móvel
perigosa		X			inofensiva
produtiva			X		destrutiva
divisível					indivisível
permanente			X		transitória
sequia			X		arriscada
incontrolável			X		controlável
detectável			X		não detectável
útil			X		inútil
crecente		X			decrecente
impalpável	X				palpável
difícil					fácil
morta					viva
invisível			X		visível
familiar					não familiar
passa através de objetos			X		não passa através de objetos
perceptível			X		imperceptível
mova por si só			X		tem que ser transportada
conhecida			X		desconhecida
abstrata	X				concreta
tem outros corpos radioativos			X		não tem outros corpos radioativos
se por contato			X		se a distância
pode ser medida		X			não pode ser medida

57

-3-

3- Você acha que o seu conhecimento sobre radioatividade é:

- nenhum  razoável  
 muito pouco  profundo  
 superficial

4- Aonde ou com quem você adquiriu a maior parte deste conhecimento?

- livros / escola / professores  televisão  
 jornais / revistas  outro, qual? \_\_\_\_\_

5- Qual o seu nível de interesse em saber mais sobre radioatividade?

- nenhum  algum  
 pouco  muito

6- Em quais dos tópicos abaixo você estaria interessado em obter mais informações? (nesta questão você pode, se desejar, marcar mais de uma alternativa)

- explicações científicas a respeito da radioatividade  
 como a radiação afeta a matéria, viva e não viva  
 aplicações da radioatividade na medicina  
 aplicações da radioatividade na produção de energia  
 aplicações da radioatividade em problemas envolvendo lixo atômico  
 acidentes envolvendo material radioativo  
 medidas de segurança e controle necessárias ao trato com materiais radioativos  
 aplicações da radioatividade na preservação e esterilização de alimentos  
 aplicações da radioatividade na indústria  
 outro, qual? \_\_\_\_\_

7- Leia com atenção a lista abaixo que contém diferentes tipos de informação sobre radioatividade e indique respostas afirmativas às perguntas feitas em seguida fazendo um círculo na letra correspondente a cada afirmativa ao lado da pergunta.

- (a) EXPLICAÇÕES CIENTÍFICAS SOBRE A NATUREZA DA RADIOATIVIDADE  
 (b) COMO A RADIAÇÃO AFETA A MATÉRIA, VIVA E NÃO VIVA  
 (c) APLICAÇÕES DA RADIOATIVIDADE EM MEDICINA  
 (d) APLICAÇÕES DA RADIOATIVIDADE NA PRODUÇÃO DE ENERGIA  
 (e) APLICAÇÕES DA RADIOATIVIDADE EM PROBLEMAS ENVOLVENDO LIXO ATÔMICO  
 (f) ACIDENTES ENVOLVENDO MATERIAL RADIOATIVO  
 (g) MEDIDAS DE SEGURANÇA NECESSÁRIAS AO TRATO COM MATERIAIS RADIOATIVOS

Dos tipos de informação listados acima, quais deles você:

- ... já possui na época do acidente com Césio 137 em Goiânia? (a) (b) (c) (d)  (e) (f) (g)  
 ... procurou, na época do acidente com Césio 137 em Goiânia? (a) (b) (c) (d) (e) (f)  (g)  
 ... foi capaz de encontrar, na época do acidente com Césio 137 em Goiânia? (a) (b) (c) (d) (e)  (f) (g)  
 ... ou já tinha ou foi capaz de encontrar e que provou ser mais útil para lhe ajudar a entender sobre radioatividade? (a) (b)  (c) (d) (e) (f) (g)  
 ... se tivesse encontrado, teria lhe ajudado a entender sobre radioatividade?  (a) (b) (c) (d) (e) (f) (g)  
 ... você ainda não entende sobre radioatividade? (a)  (b) (c) (d) (e) (f) (g)

**APPENDIX 7.2**

**FACTOR ANALYSIS  
FOR ALL  
SEMANTIC DIFFERENTIAL DATA**

APPENDIX 7.2

Orthogonal Transformation Solution-Varimax

	Factor 1	Factor 2	Factor 3	Factor 4	Factor 5	Factor 6	Factor 7	Factor 8
MATERIAL	.1	-.393	.344	.181	.192	.176	.178	.012
MOMENT...	.072	.019	.016	.072	-.761	-.046	-.071	-.009
COMPLEX	-.087	-.006	.391	-.345	-.075	.193	.045	.202
STRONG	-.392	.133	.216	.022	.13	.169	.236	.203
AMORPH...	-.029	.673	.211	-.092	.153	.076	-.107	.015
BRIEF	.003	.047	-.085	-.074	-.759	-.043	.042	-.053
ORDINARY	.213	.277	-.369	.371	-.099	-.107	-.082	.21
PASSIVE	.08	.023	.001	.147	-.03	-.026	-.723	.14
SOLID	-.054	-.558	.041	.192	.168	-.087	-.081	.009
IS ALWA...	.158	.018	.259	-.007	.287	-.15	.069	.005
NATURAL	.165	-.057	.049	.671	-.04	-.017	.051	-.055
ENERGETIC	.246	2.439E-4	.027	.044	.016	-.032	.723	.072
SPREAD	-.185	.228	-.044	-.016	-.075	.122	.228	.496
FREQUENT	.415	.22	-.076	.257	-.129	.021	.082	-.083
DESTRUC...	-.779	-.067	-.028	-.082	-.04	.069	-.058	.079
HAS TO B...	.055	.097	.054	-.737	-.064	.066	.121	-.024

	Factor 1	Factor 2	Factor 3	Factor 4	Factor 5	Factor 6	Factor 7	Factor 8
LIGHT	.181	.044	.095	.014	-.096	-.153	-.002	.051
STABLE	.072	-.152	-.022	-.112	.118	-.069	-.065	-.117
HARMFUL	-.832	.021	-.053	-.039	.016	.024	.045	.05
POWERFUL	-.244	-.023	.444	.036	.084	-.008	.475	-.101
NOT COM...	-.072	-.199	-.635	-.002	.069	.05	.094	.051
STILL	.003	-.183	-.079	.095	.083	-.061	-.182	-.156
DANGERO...	-.582	-.084	.125	-.07	.168	.033	.206	-.089
PRODUCT...	.785	-.01	.016	-.007	.001	-.039	.019	-.088
DIVISIBLE	.154	-.367	-.071	.03	-.004	.3	.094	.287
PERMANE...	-.065	.025	-.108	.072	.372	.061	.175	-.377
SECURE	.471	-.07	-.306	.087	-.123	-.016	-.032	.038
UNCONTR...	-.422	.043	-.201	-.067	.178	.052	-.119	-.116
DETECTA...	.135	-.022	.581	-.029	.098	-.074	.118	.033
USEFUL	.639	-.033	.189	-.067	.047	-.052	.17	.098
INCREASI...	-.12	.001	-.015	-.011	.243	.679	.06	.049
INTANGIB...	.012	.714	.044	.095	-.083	-.057	.071	.016

APPENDIX 7.2

	Factor 1	Factor 2	Factor 3	Factor 4	Factor 5	Factor 6	Factor 7	Factor 8
DIFFICULT	-.039	.017	.053	-.12	-.065	.001	.098	-.01
DEAD	.088	-.061	.025	.139	.077	-.729	.047	.067
INVISIBLE	.121	.579	-.087	.068	-.006	.031	-.011	.027
FAMILIAR	.108	-.053	-.028	.01	-.071	-.011	-.078	.086
PASSES...	.034	.036	.339	.321	-.01	.361	-.017	-.043
PERCEPTI...	.05	.003	-.001	-.06	.115	.09	.031	.01
MOVESB...	-.057	.188	-.01	.098	.011	.1	-.051	-.052
KNOWN	-.027	.134	-.019	.172	-.033	.062	.157	.175
ABSTRACT	-.015	.452	-.055	-.092	.042	.125	-.009	.059
MAKES O...	-.022	.064	.075	.132	.081	.06	-.014	-.027
ACTS BY ...	-.085	-.051	-.038	-.017	.123	-.064	-.159	.734
CAN BE ...	.294	-.084	.222	-.154	.064	-.286	.137	-.163

Orthogonal Transformation Solution-Varimax

	Factor 9	Factor 10	Factor 11	Factor 12	Factor 13	Factor 14	Factor 15
MATERIAL	-.068	.212	-.066	.05	-.07	-.309	-.036
MOMENT...	-.104	-.02	.115	.133	-.031	-.008	.01
COMPLEX	.029	.267	-.088	-.091	.035	.167	.147
STRONG	.161	.123	-.051	-.103	.148	.169	-.267
AMORPH...	-.019	-.133	-.108	.014	-.039	.058	.014
BRIEF	-.015	.138	.011	-.017	.035	-.085	2.433E-4
ORDINARY	-.132	-.02	-.108	.263	-.089	.061	.182
PASSIVE	.18	.041	.089	-.008	.093	.002	.012
SOLID	.029	-.027	-.103	-.032	.318	-.035	.044
IS ALWA...	-.155	.197	-.554	.038	-.039	.129	-.131
NATURAL	-.058	.184	.008	.055	-.11	.043	-.15
ENERGETIC	.19	-.002	.085	-.152	.099	-.022	.001
SPREAD	.027	-.002	-.168	.149	-.106	.146	.222
FREQUENT	.239	-.084	-.229	.288	.01	.109	.077
DESTRUC...	-.094	.047	-.064	.088	.02	.031	-.054
HAS TO B...	-.036	.047	.03	.057	.024	-.038	-.178

APPENDIX 7.2

	Factor 9	Factor 10	Factor 11	Factor 12	Factor 13	Factor 14	Factor 15
LIGHT	-.203	.087	.621	.203	-.153	.088	.053
STABLE	.727	.077	-.001	.192	-.118	.016	-.058
HARMFUL	.063	.033	.022	.017	.058	-.008	-.064
POWERFUL	-.015	-.01	-.023	.118	.163	.141	.164
NOT COM...	-.142	.027	-.023	.215	-.137	.029	-.06
STILL	.226	.055	-.074	.242	.248	-.014	-.657
DANGERO...	.054	-.157	.284	-.125	.111	.141	-.084
PRODUCT...	.064	.034	.107	.07	.102	.025	-.126
DIVISIBLE	.03	.082	-.029	-.108	.024	.41	-.049
PERMANE...	-.137	.038	-.049	.143	-.2	.034	-.131
SECURE	-.055	.218	-.092	.095	-.031	-.443	.013
UNCONTR...	.111	.372	-.266	-.015	.206	.049	.254
DETECTA...	-.212	-.046	-.065	.17	-.117	.128	-.098
USEFUL	-.006	-.105	.042	.132	.01	.191	-.261
INCREASL...	-.033	-.012	.168	.118	.072	-.017	.091
INTANGIB...	-1.62E-4	-.014	.001	-.107	.103	-.087	.218

	Factor 9	Factor 10	Factor 11	Factor 12	Factor 13	Factor 14	Factor 15
DIFFICULT	-.112	-.079	-.042	-.044	.761	.054	-.039
DEAD	-.002	.048	.155	.116	.08	-.045	-.055
INVISIBLE	-.242	.376	.125	.037	.04	.034	.171
FAMILIAR	.109	-.004	.101	.801	-.004	-.076	.03
PASSES ...	-.084	-.228	.055	.007	-.051	.185	-.01
PERCEPTI...	-.037	-.806	-.042	.006	.081	.007	.068
MOVES B...	.071	.005	.065	.173	.082	.039	.782
KNOWN	.43	-.095	-.02	-.132	-.417	.061	.01
ABSTRACT	.17	.179	.471	-.046	.109	.08	.034
MAKES O...	.029	.04	.036	-.007	.039	.797	.026
ACTS BY ...	-.116	-.006	.125	.082	-.054	-.091	-.095
CAN BE ...	-.159	-.02	-.187	-.039	-.325	.436	.121



**APPENDIX 9.1**  
**SEMANTIC NETWORKS**

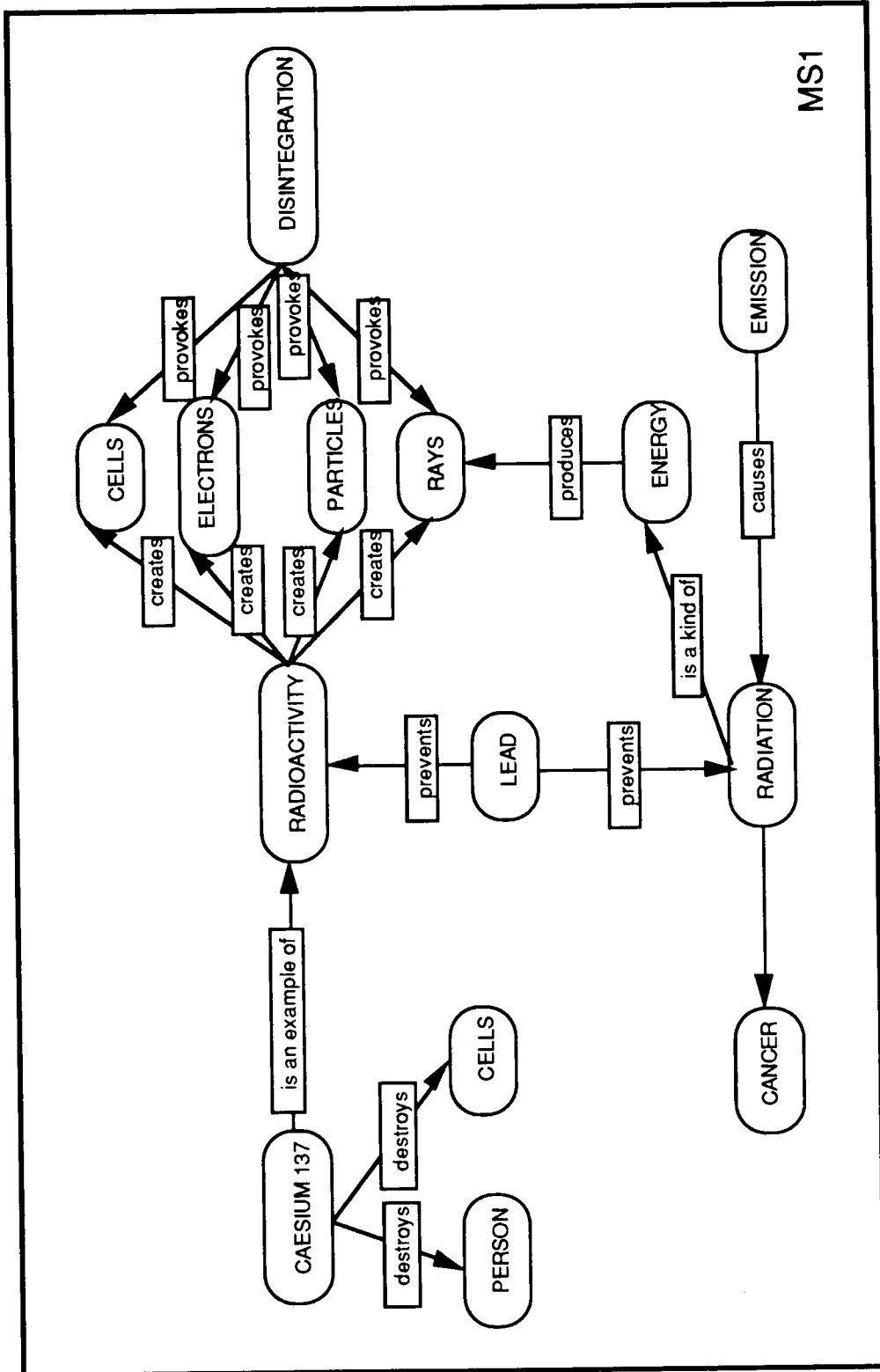

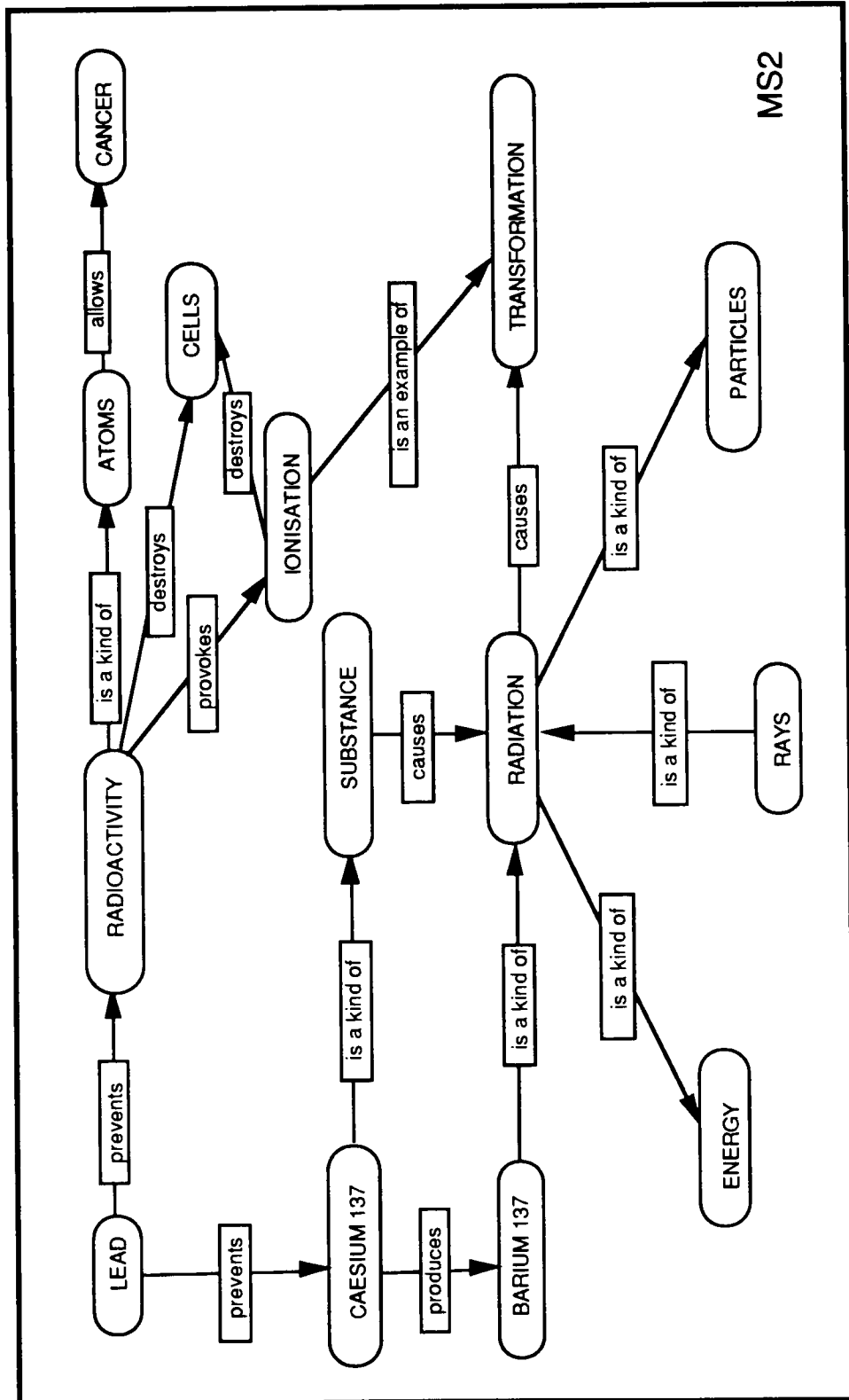

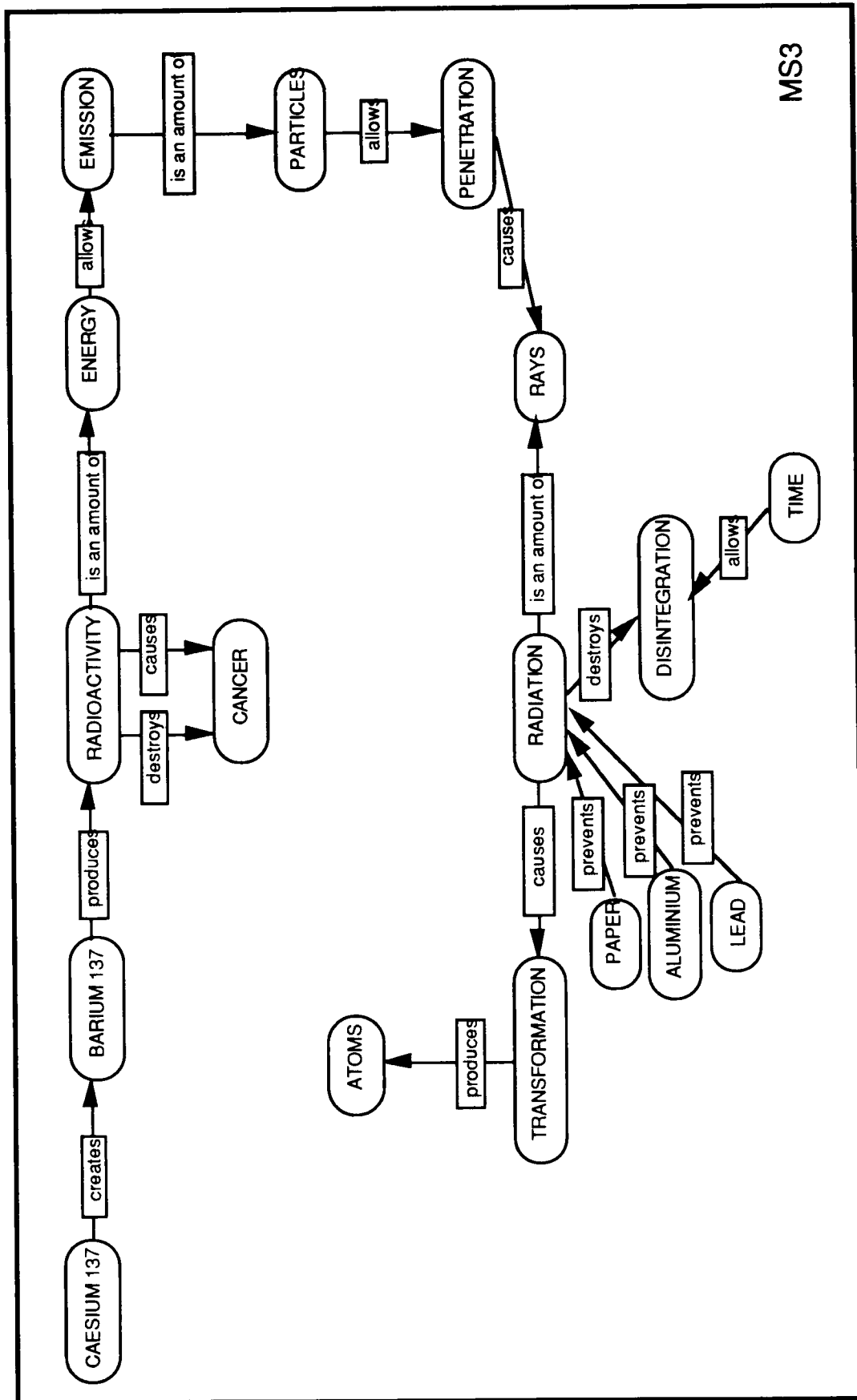

MS3

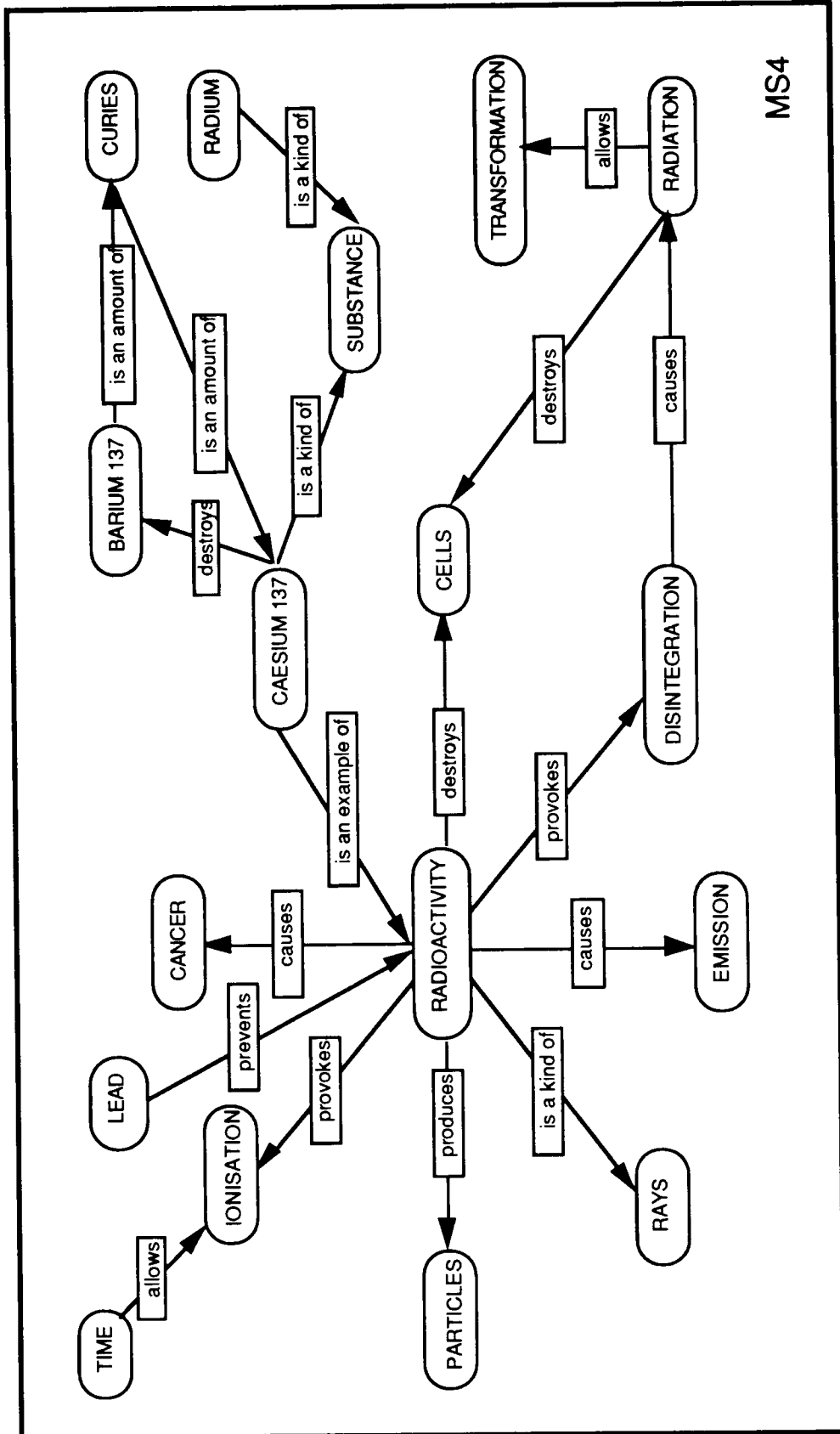

MS4

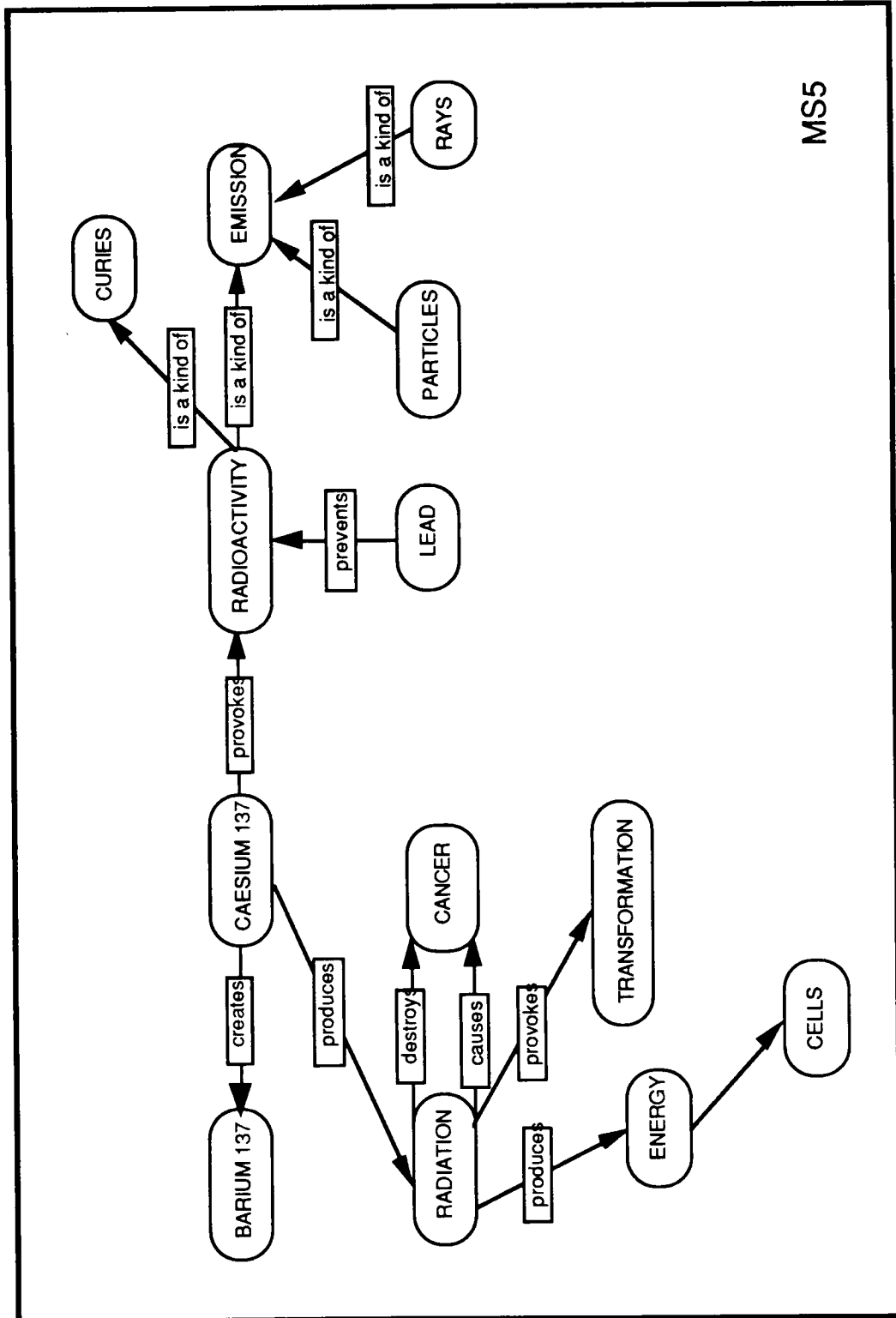

MS5

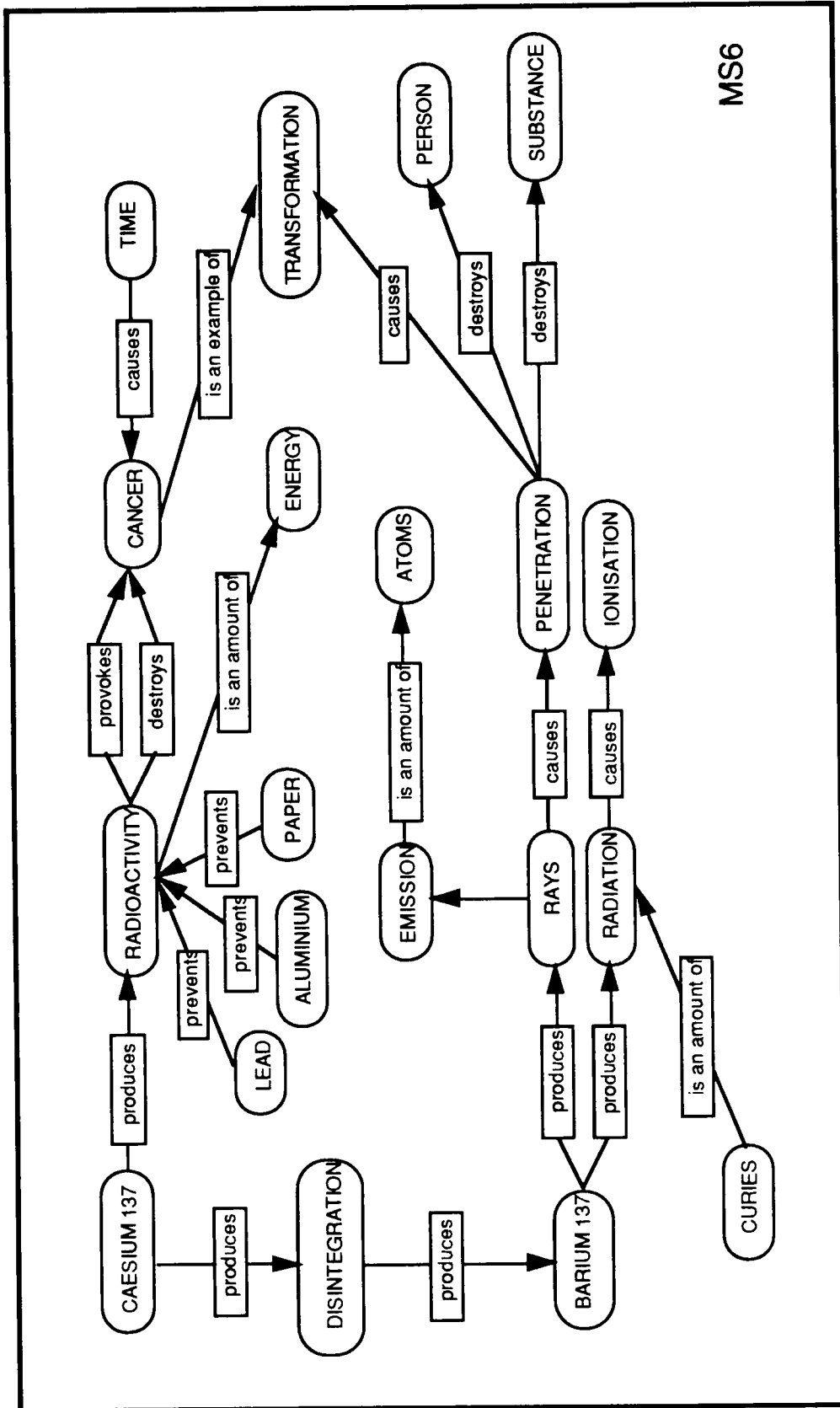

MS6

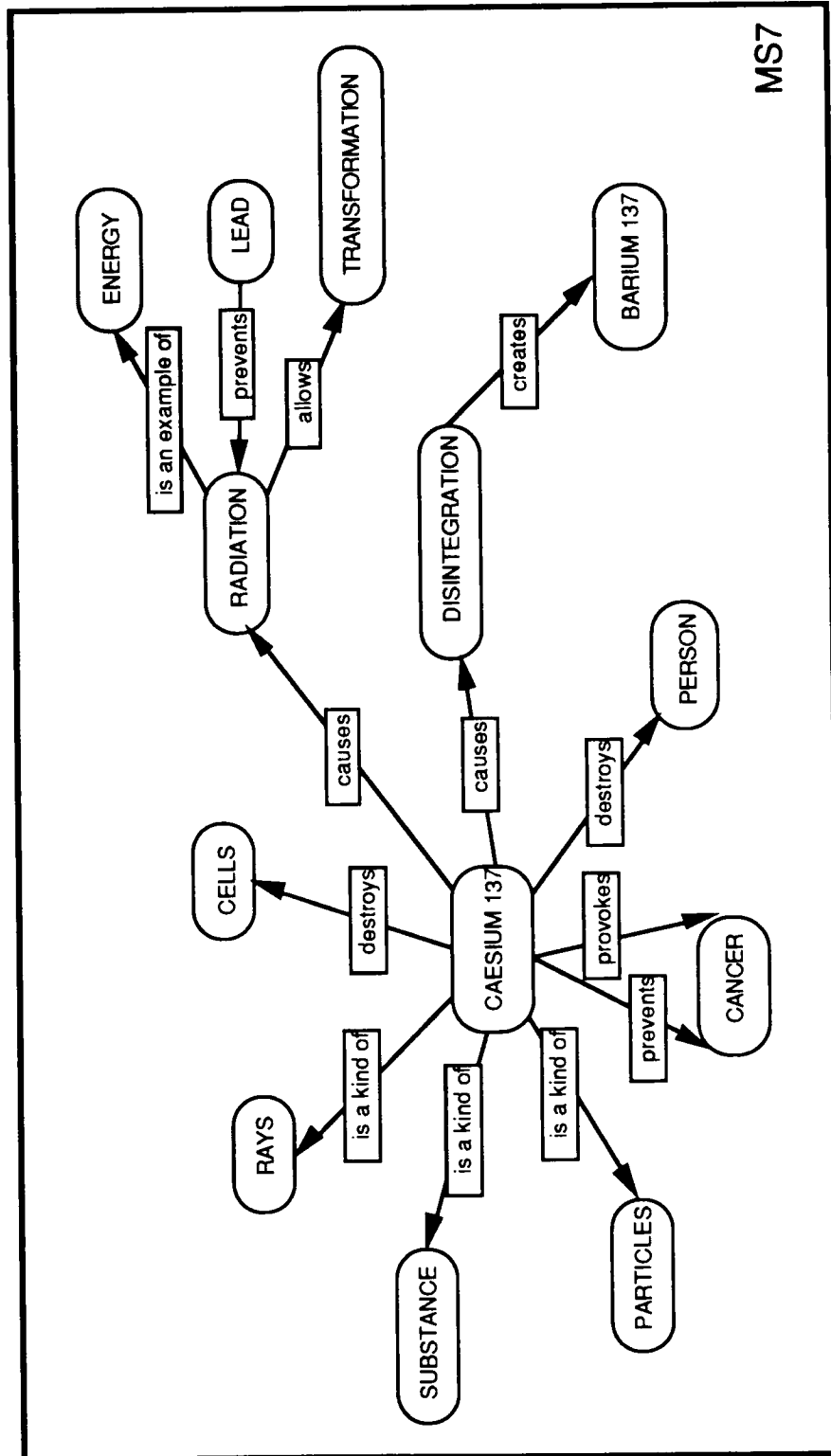

MS7



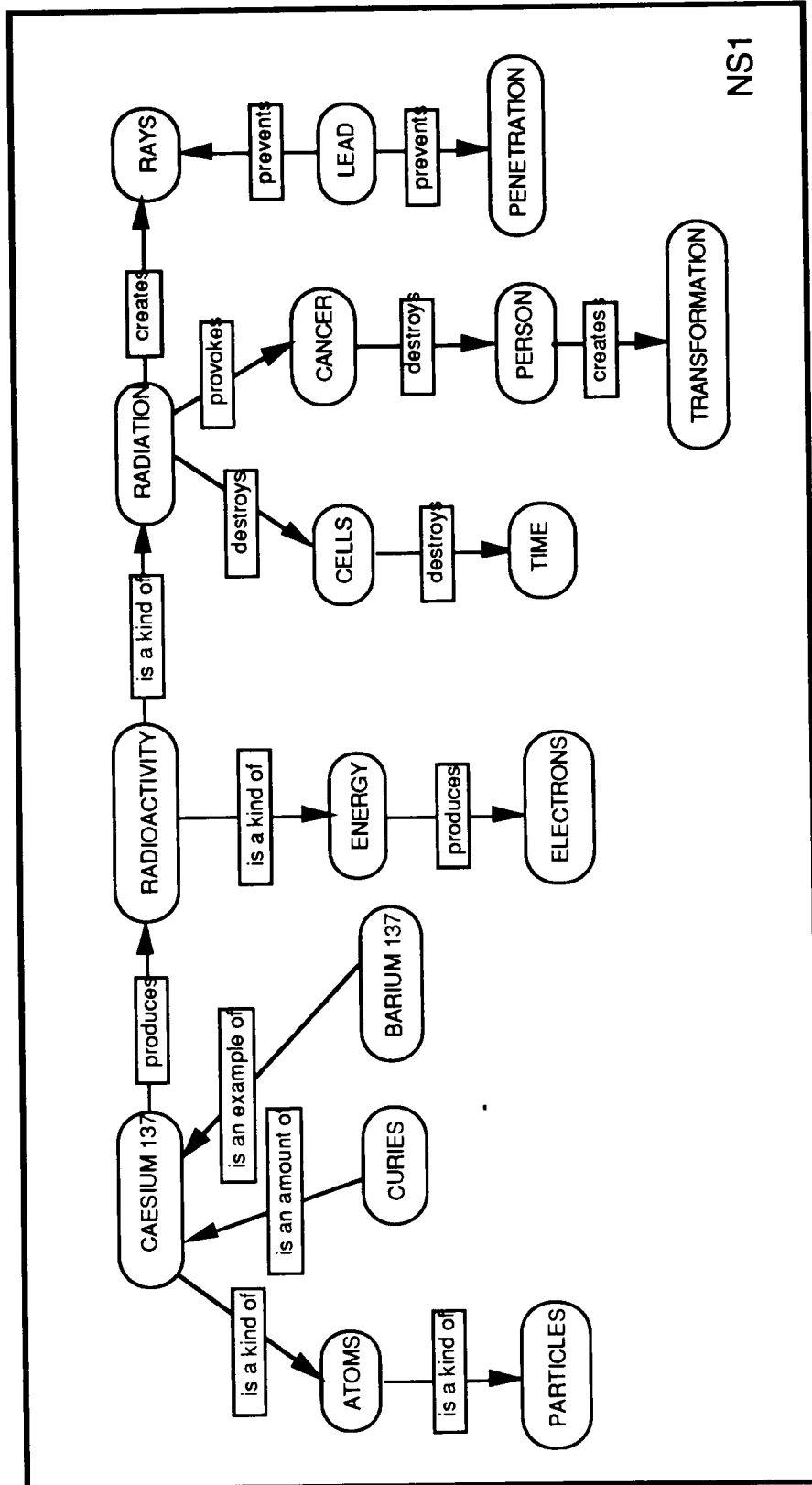

NS1

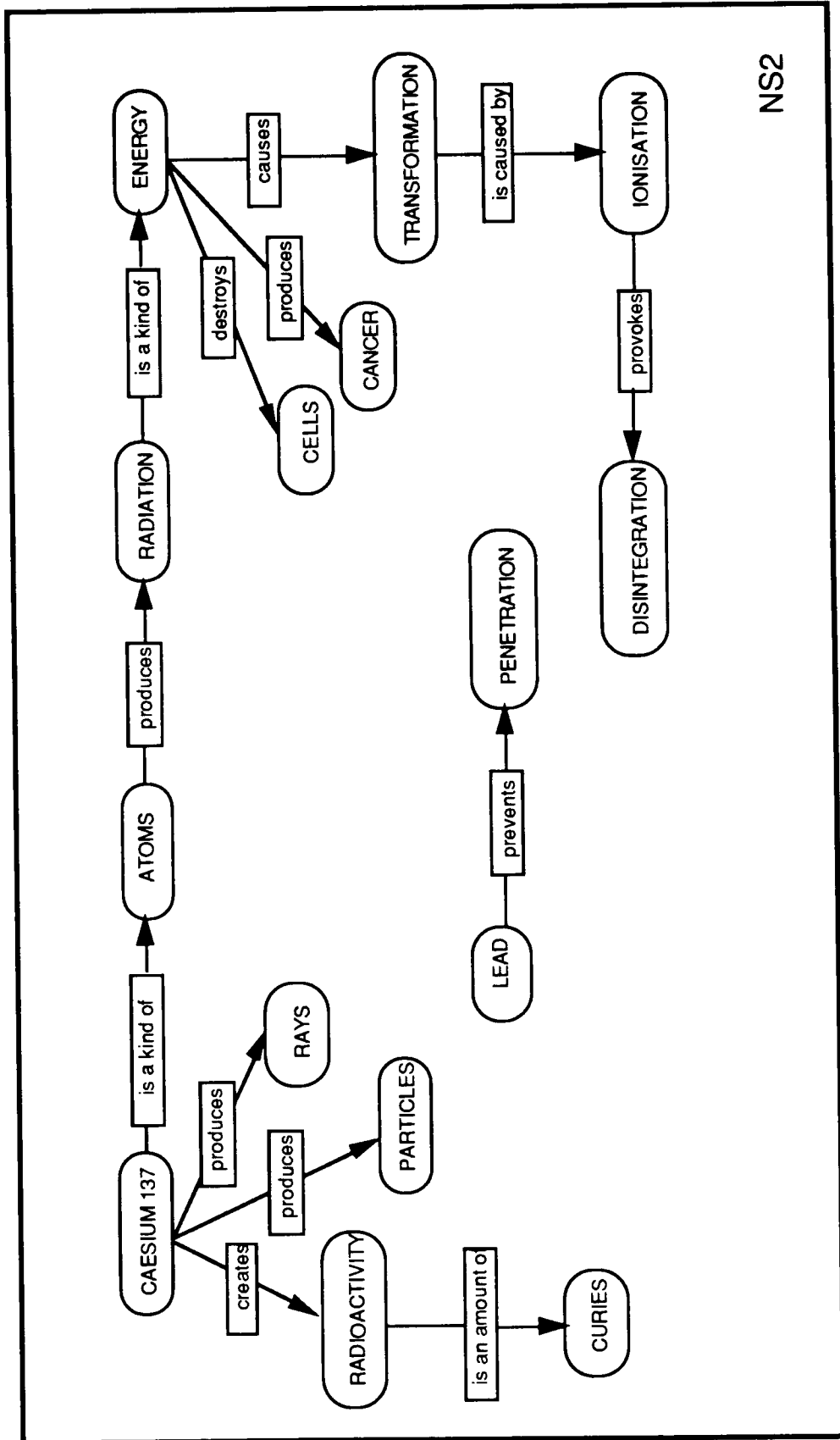

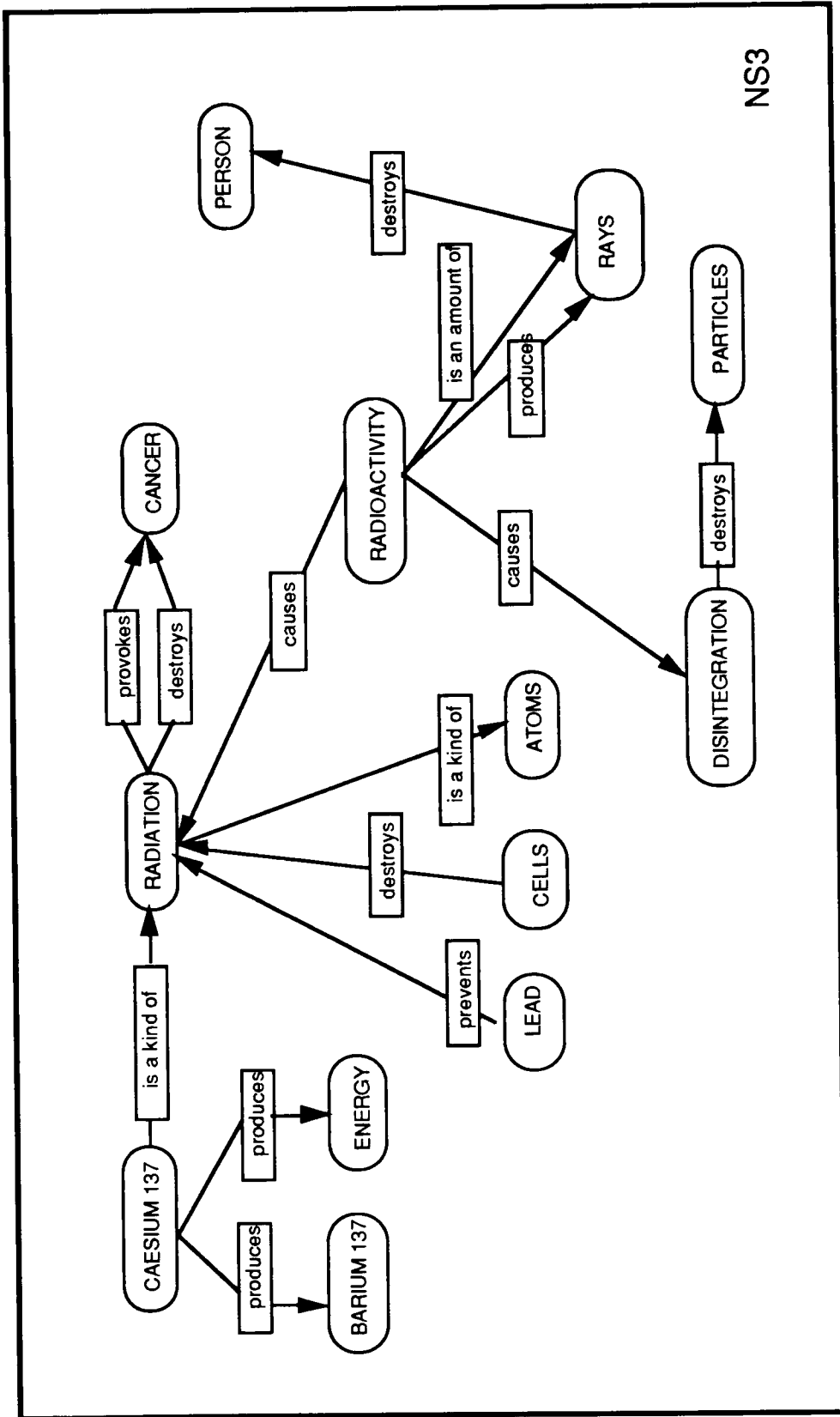

NS3

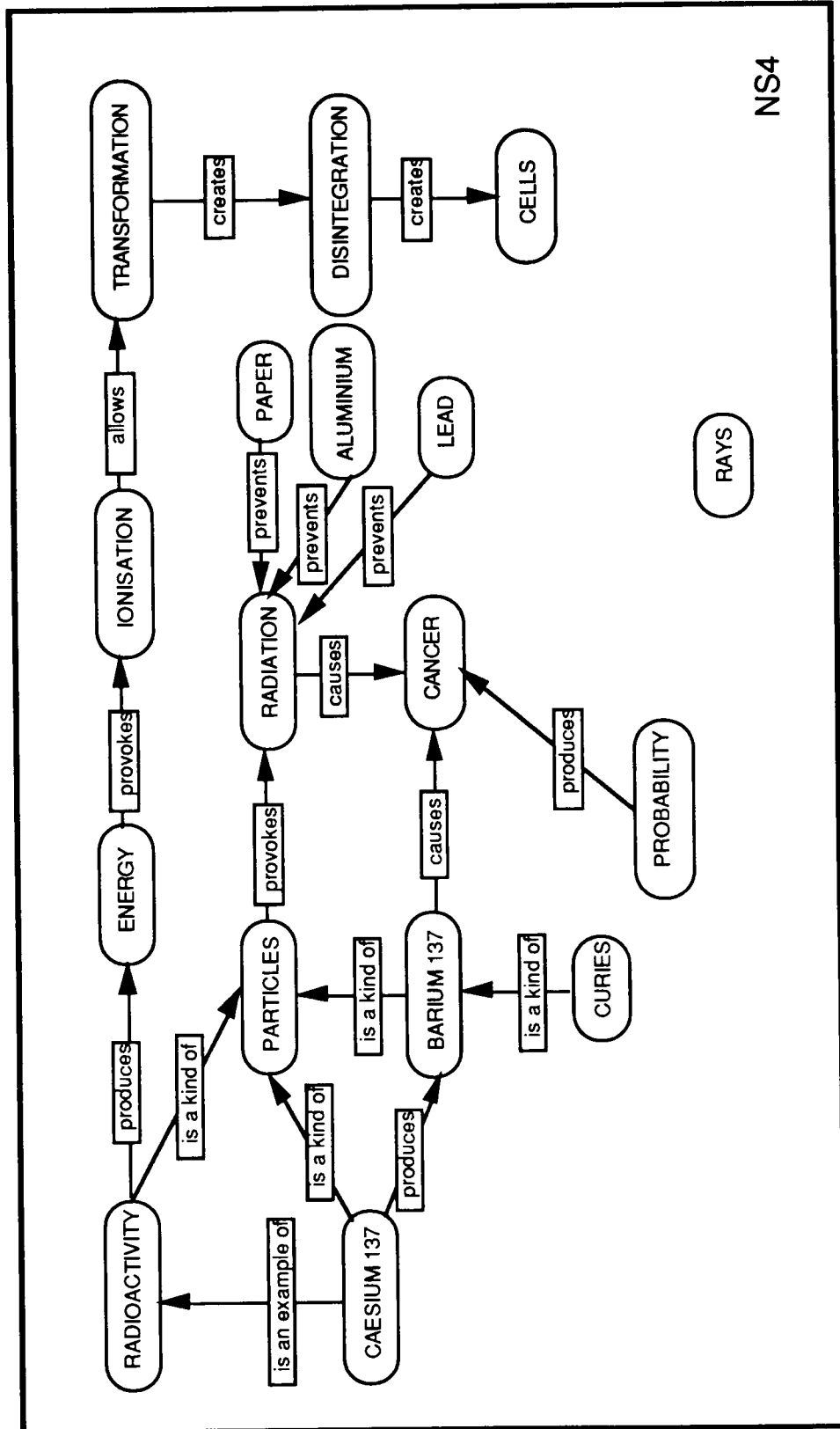

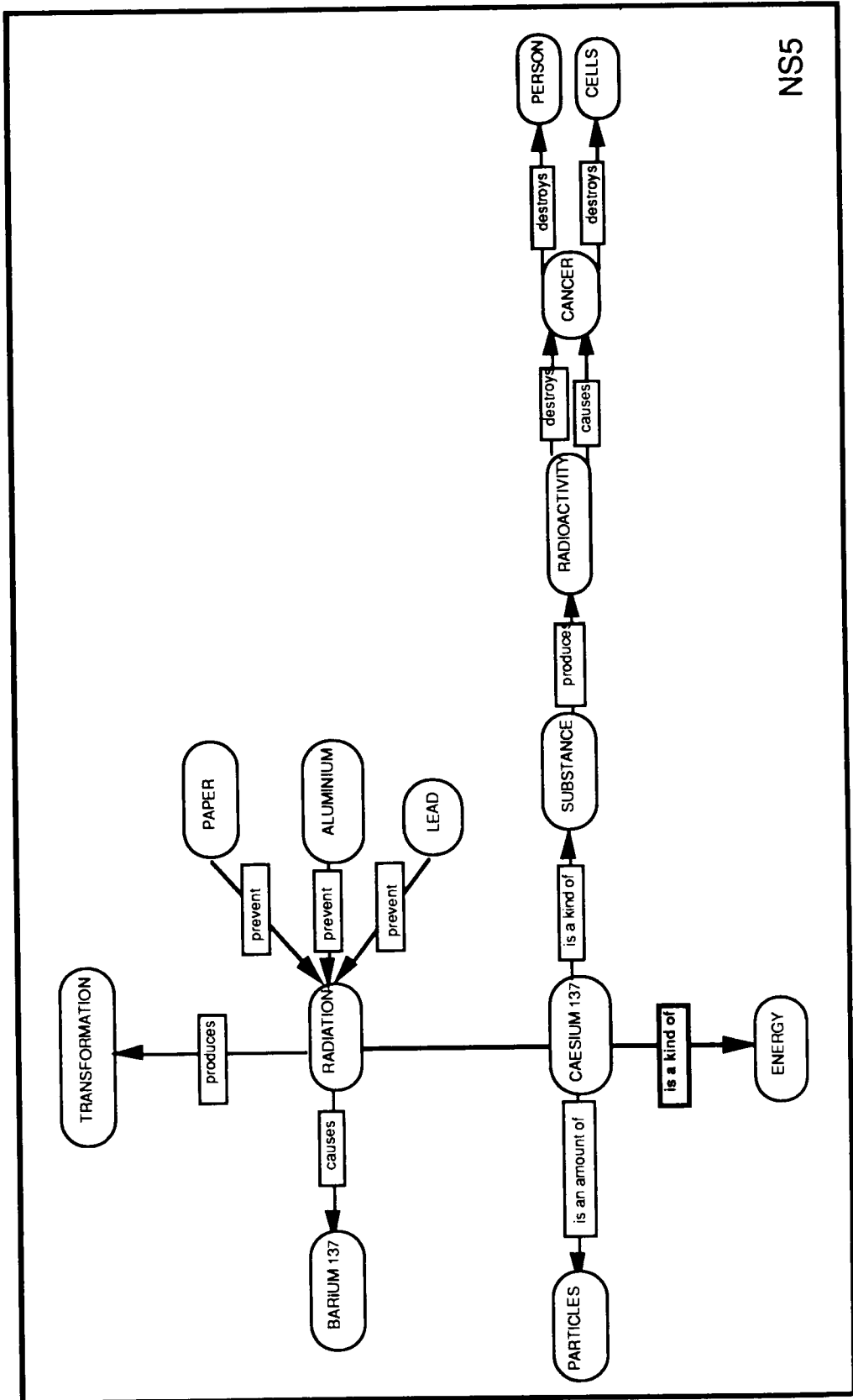

NS5

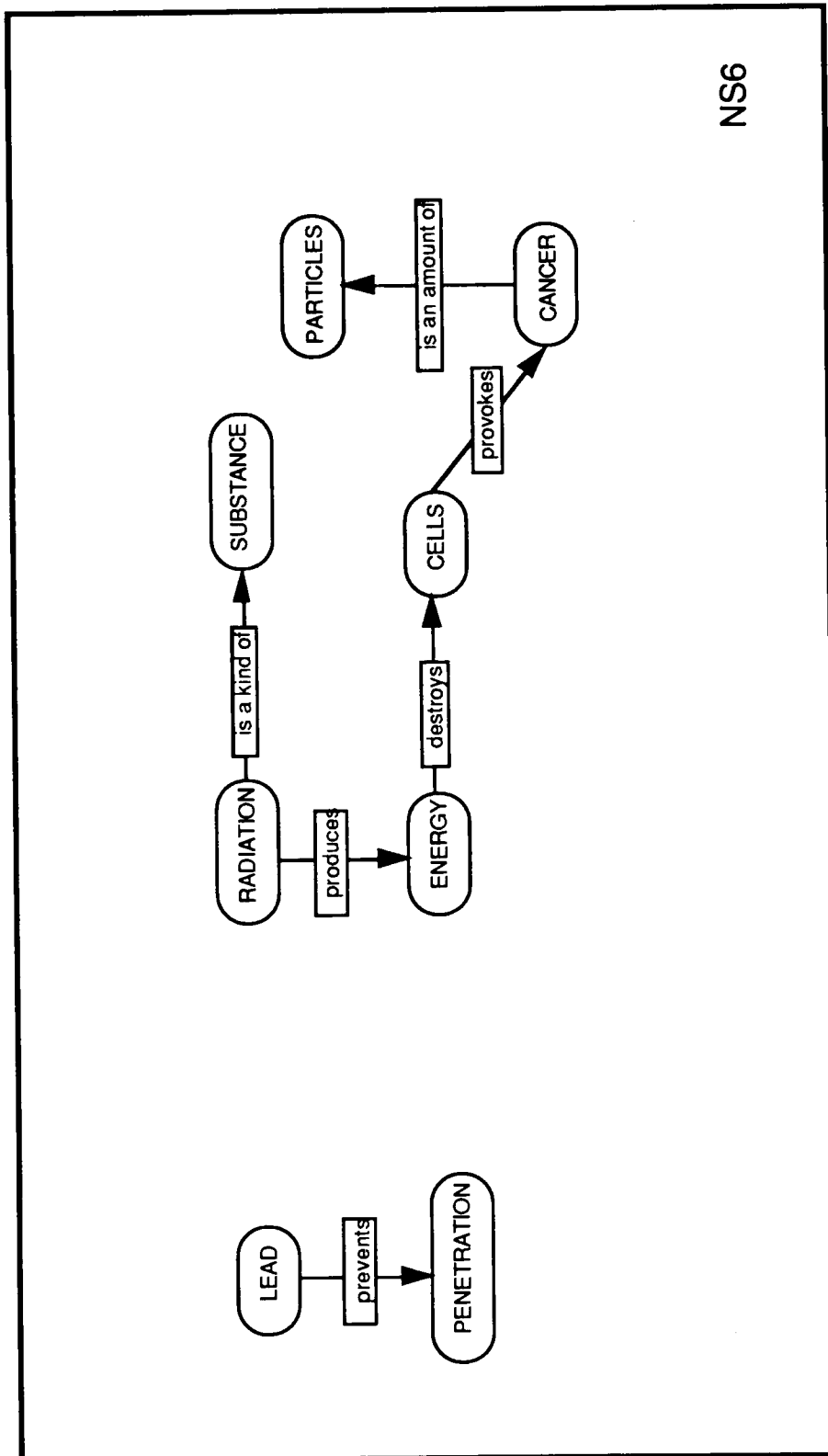

NS6

**APPENDIX 10.1**

**TEACHERS' QUESTIONNAIRE**

Sexo  M  F T26 Leciona em escola  Técnica  Pública  Particular  
 Matéria(s) que leciona Biologia  
 Leciona há quantos anos? 20 anos

O questionário abaixo foi aplicado em estudantes do segundo grau formação geral do Rio de Janeiro. Os estudantes responderam o questionário individualmente e foram avisados que não havia respostas certas ou erradas uma vez que a pesquisadora estava interessada nas ideias próprias que os estudantes possuíam sobre o assunto e que o questionário não valia nota.

Queríamos que você, professor, respondesse a este questionário tentando prever o tipo de respostas dadas pelos estudantes. Tente se colocar no lugar de um estudante típico e pensando na sua experiência sobre o tipo de ideias que os estudantes possuem, responda às duas questões que se seguem. Muito obrigada pela sua colaboração.

1- Nesta questão apresentamos uma lista relacionando conceitos em física, objetos da experiência diária, elementos da natureza, etc. Pedimos que você leia esta lista com atenção e pense se a radioatividade pode ser vista, pensada ou entendida como alguma opções propostas. Você deve indicar suas respostas marcando um X nas lacunas correspondentes a SIM ou NÃO para cada item, pensando em como os estudantes responderiam a esta questão.

Você acha que a RADIOATIVIDADE, de alguma forma, se parece com:

	SIM	NÃO
o ar		X
ondas	X	
uma nuvem	X	
raios	X	
poeira	X	
água		X
raios-X		X
um campo magnético		X
eletricidade	X	
calor	X	
um objeto		X
luz	X	
energia	X	
som		X
movimento		X
um gás	X	
tumores	X	

2- Nesta questão nós gostaríamos que você avaliasse o conceito de radioatividade em relação a uma série de escalas que estão divididas em cinco intervalos e que contém em seus extremos dois adjetivos que são complementares em significado. Leia as instruções com atenção e responda a cada um dos itens separadamente sem tentar checar itens que lhe pareçam similares. Faça seu julgamento baseado no que o conceito de radioatividade significa para você tendo cuidado para não "pular" nenhum item. Proceda da seguinte forma:

Marque esta posição se você considerar o adjetivo da **esquerda** PERFEITAMENTE adequado para se referir à radioatividade

Marque esta posição se você considerar o adjetivo da **direita** PERFEITAMENTE adequado para se referir à radioatividade

Marque esta posição se você considerar o adjetivo da **esquerda** PARCIALMENTE adequado para se referir à radioatividade

Marque esta posição se você considerar o adjetivo da **direita** PARCIALMENTE adequado para se referir à radioatividade

Marque esta posição se você considerar que **ambos** adjetivos são IGUALMENTE adequados para se referir à radioatividade

Vire a página para responder às perguntas da questão 2.



Pense em um estudante pensando sobre

RADIOATIVIDADE

você acha que ele responderia que a radioatividade é

Você acha que cada resposta do estudante reflete um entendimento real do que é perguntado? Indique SIM ou NÃO para cada um deles.

SIM NÃO

materiais		X			imateriais		X
momentâneas	X				eternas		X
complexas			X		simples		X
fortes	X				fracas		X
amorfos		X			tem forma		X
efêmeras	X				duradouras		X
comuns			X		especiais		X
passivas	X				ativas		X
solitas				X	fluidas		X
está sempre ali	X				que vai e volta		X
natural			X		artificial		X
energética	X				inerte		X
espalhada	X				localizada		X
frequente	X				rara		X
destruidora	X				criadora		X
tem que ser fabricada	X				crece por si so		X
leve	X				pesada		X
estável			X		instável		X
prejudicial	X				benéfica		X
poterosa	X				impotente		X
é composta de partículas			X		e composta de partículas		X
imóvel				X	móvel		X
perigosa	X				inofensiva		X
produtiva			X		destrutiva		X
divisível	X				indivisível		X
permanente	X				transitória		X
segura			X		arriscada		X
incontrolável	X				controlável		X
detectável	X				não detectável		X
útil			X		inútil		X
crecente	X				decrecente		X
impalpável	X				palpável		X
difícil			X		fácil		X
morta			X		viva		X
invisível	X				visível		X
familiar	X				não familiar		X
passa através de objetos	X				não passa através de objetos		X
perceptível			X		imperceptível		X
move por si so	X				tem que ser transportada		X
conhecida	X				desconhecida		X
abstrata	X				concreta		X
tem na outros corpos radioativos	X				não tem na outros corpos radioativos		X
age por contato	X				age a distância		X
pode ser medida	X				não pode ser medida		X

- 3 -

Finalmente gostaríamos que você, professor, tentasse se lembrar do tipo de pergunta que seus estudantes ou talvez pessoas amigas (amigos, parentes, conhecidos, etc.) lhe fizeram na época do acidente radiológico de Goiânia em 1987. Apresentamos abaixo uma lista de possíveis tipos de informação relacionada à radioatividade que foram, provavelmente, divulgadas pelos meios de comunicação da época. Por favor, indique os tipos mais comuns de dúvidas ou perguntas dos estudantes e dos leigos que chegarão até você.

- explicações científicas a respeito da natureza da radioatividade
- como as radiações afetam a matéria viva e a matéria não viva
- aplicações da radioatividade em medicina
- aplicações da radioatividade na produção de energia
- aplicações da radioatividade em problemas envolvendo lixo atômico
- acidentes envolvendo materiais radioativos
- medidas de segurança e controle necessários ao trato com materiais radioativos
- outro tipo, qual: Relacionando erroneamente causa e efeito

Você seria capaz de dar exemplos deste ou de outro tipo de pergunta que lhe tenham sido feitas ou que você ache que tenha sido motivo de preocupação para o público em geral?

(1) Que tipo de defeito a radioatividade contém no leite ou na carne provocando naqueles que os usam como alimento

(2) Que qualquer forma e grau de radioatividade sejam prejudiciais

(3) Complicta ignorância sobre a existência de uma radioatividade natural

Você acha que o nível de interesse dos estudantes em saber mais sobre radioatividade é

- nenhum
- muito pouco
- superficial
- razoável
- profundo

Você acha que a maior parte do conhecimento que os estudantes possuem sobre radioatividade foi adquirida em

- livros/escola/professores
- jornais/revistas
- televisão
- outro meio, qual: \_\_\_\_\_

### APPENDIX 6.3: Multidimensional Scaling

The objective of multidimensional scaling is, for given information about “relative distances” between a set of points, to find a spatial configuration (that is, a set of co-ordinate values) of these points, preferably in a small number of dimensions. The idea is analogous to building a map of England from data on road distances between all pairs of English towns.

The term “distance” is used to describe any measure of dissimilarity and are often derived from measures of similarity. Examples of such measures are relative frequencies (number of choices for which pairs of items are thought to be similar) or correlations (indicating how similar choices between different items across individuals are). There are also direct measures of dissimilarity like, for example, Jardine & Sibsons’s dissimilarity functions.

In our case distances were calculated by subtracting the value of the correlations between answers for each entity across individuals from one.

Methods for finding out the configuration of points may derive the calculation of co-ordinate values from: (a) Euclidean distances (either through the data matrix  $X$  or through the matrix  $B=XX^T$ , which is the matrix of between-individuals sum of squares and products (scalar product of point vectors); (b) the use of the rank order of dissimilarity only. This method is particularly useful when measures of dissimilarity have little intrinsic meaning (as in arbitrary scoring of choices in a scale), and, for this reason, was preferred in our case.

The interpretation of the number of dimensions yielded in the solution then relates to underlying features of the data. Some criteria for deciding on the “true” dimensionality of the solution may be derived from the examination of stress and RQS values for solutions with different number of dimensions. The stress can be understood as a goodness of fit for a given solution and is calculated in terms of “distances” and dissimilarities. It is equal to the square root of the sum of squares over a scaling factor, which are, respectively:

$$SS = \sum_{i=1}^{n-1} \sum_{j=i+1}^n (\delta_{ij} - d_{ij})^2$$

$$SC = \sum_{i=1}^{n-1} \sum_{j=i+1}^n d_{ij}^2$$

Observed values for stress are generally “evaluated” against values given by Kruskal’s rules of thumb (1964) and it is possible to say that good fits are obtained when the value for the stress is equal or less than 5%.

RQS values are the proportion of the variance of scaled data (disparities) in the partition which is accounted for by their corresponding distances. The bigger the value of RQS the greater proportion of variance is explained.

