

DYNAMICAL SYSTEMS IN COSMOLOGY

Supervisor

Dr. Christian G. Böhrer

Co-supervisor

Dr. Stephen A. Baigent

Nyein Chan

Department of Mathematics

University College London

A thesis submitted for the degree of
Doctor of Philosophy

2012

DECLARATION

I, Nyein Chan, confirm that the work presented in this thesis is my own. Where information has been derived from other sources, I confirm that this has been indicated in the thesis.

Chapter 4 is based on the paper “Quintessence with quadratic coupling to dark matter” published in Physical Review D (Vol.81, No.8). Chapters 5 and 6 are based on the paper “Dynamics of dark energy models and centre manifolds” (eprint arXiv:1111.6247 [gr-qc]). The figures 4, 5, 6, 7, 8, 9, 10, 11, 15 and 16 are kindly provided by Ruth Lazkoz.

Abstract

In this PhD thesis, the role of dynamical systems in cosmology has been studied. Many systems and processes of cosmological interest can be modelled as dynamical systems. Motivated by the concept of hypothetical dark energy that is believed to be responsible for the recently discovered accelerated expansion of the universe, various dynamical dark energy models coupled to dark matter have been investigated using a dynamical systems approach. The models investigated include quintessence, three-form and phantom fields, interacting with dark matter in different forms. The properties of these models range from mathematically simple ones to those with better physical motivation and justification. It was often encountered that linear stability theory fails to reveal behaviour of the dynamical systems. As part of this PhD programme, other techniques such as application of the centre manifold theory, construction of Lyapunov functions were considered. Applications of these so-called methods of non-linear stability theory were applied to cosmological models. Aforementioned techniques are powerful tools that have direct applications not only in applied mathematics, theoretical physics and engineering, but also in finance, economics, theoretical immunology, neuroscience and many more. One of the main aims of this thesis is to bridge the gap between dynamical systems theory, an area of applied mathematics, and cosmology, an exciting area of physics that studies the universe as a whole.

ACKNOWLEDGEMENTS

This Doctoral Thesis is dedicated to my motherland Republic of the Union of Myanmar, my alma mater, my family and my teachers. Since my birth and up to the present, I am indebted to many people. I would like to thank them all in no particular order but as per academic traditions I, first of all, would like to offer my heartiest thanks to my supervisor Dr. Christian Böhmer. This PhD thesis would not have been possible without his guidance, support, understanding, patience and professionalism. It has been a great honour, privilege and pleasure for me to have worked under him.

Next, my admiration and deep gratitude go to my father Lieutenant Commander Sun Maung (Myanmar Navy Retd.), whose wisdom and foresight have enabled me to be able to study in the United Kingdom. I am also indebted to my late mother Daw Thazin who had dedicated all out to my education as well as my development as a person. It is virtually impossible to completely describe in words, her love and support all through my life for me to have made achievements in my life. I also thank my brother Wai Min who motivates me to work harder to become an exemplary person for him as an elder brother.

I wish to thank all my teachers from University College London (UCL), all those in the UK and around the world, who have supported me throughout my academic journey and life. In particular, I wish to thank Dr. Peter Doel, Mr. David Lefevre, Dr. Stan Zochowski, Dr. Keith Norman, Dr. Johannes Bauer, Mr. Mike Corbett, Mr. Robert Charlton, Dr. Htay Lwin, Daw Khin Swe Gyi, Mr. Philip Thacker and Miss Christine Duce for their kindness and directions given. I am obliged to mention my gratitude owed to the schools I attended in Tokyo, Japan. They are Jinan Elementary School, Shoto Junior High School and Ichigaya Senior High School of Commerce. I also thank my teachers from Notre Dame Catholic Sixth Form College, Leeds, UK. My thanks also goes to each and every PhD colleague of mine from the Department of Mathematics as well as my friends and ex-classmates from other departments and universities, especially to Daniel Ellam, Pete Kowalski, Jamie Rodney, Tom Ashbee, Ali Khalid, Louise Jottrand, Ben

Willcocks, Joe Pearce, Niko Laaksonen, Edgardo Roldán Pensado, Pablo Soberón Bravo, Atifah Mussa, Nicola Tamanini, Dr. James Burnett and James Oldfield from Mathematics, Mae Woods from CoMPLEX, Katarina Markovic, Alan Nichols, Guy Brindley, Elisbieta Paplawska, Warrick Ball, Flight Lieutenant Lee Harrop (Royal Air Force), Dr. Daniel Went, Sebastian Meznaric, Fotini Economu and Adam Hawken, formerly or currently, from Physics & Astronomy, Dr. Susanna Davis, Dr. Nick Skipper, Dr. Tim Osborne and Dr. Mohammed Eisa from the UCL Medical School, Dr. Vicky Kosta from European University Institute, my ex-flatmate Es Davison, and my ex-colleagues from ULU Noppadol Chamsai, Mirissa Ladent and Maria Pitkonen for their friendship and being a part of my life. I am also grateful to Dr. Mark Roberts, departmental tutor to undergraduate students, for offering opportunities to teach. I also thank my research collaborators Dr. Gabriela Caldera-Cabral, Dr. Ruth Lazkoz and Prof. Roy Maartens. I am also very grateful to Prof. Valery Smyshlyaev for the award of a scholarship.

I would like to thank all my childhood friends from alma mater Practising High School, Yangon Institute of Education (former Teachers' Training College), especially to each and every single one from Section F (Class of 2002). Much of the strength, courage and support needed to overcome the life's hurdles stems out of my friendship with Andrew Bawi Lyan Uk, Khine Min Htoo, Yupar Myint, May Chan Oo, Kyaw Htut Swe, Su Sandi Win, Chan Myae San Thwin, Haemar Min Thu, Captain Dr. Phyo Kyaw, Lieutenant Dr. Khaing Thinzar Kyaw, Captain Myo Thiha Zaw, Lieutenant S.G. Nay Lynn Htun, Banyar Aung, Ye Thwe Thant Zin, Thura Soe, Thu Rein Kyaw, Si Thute Aung, Zin Hlyan Moe, Saw Aye Chan Myint Oo, Ye Myat Ko, Hein Soe Aung, Win Ei Khine, Dr. Nay Thu Soe, Khine Wint Swe, Lei Sandi Aung, Dr. Khin Kathy Kyaw, Dr. Lawrence Thang, Dr. Kay Zin Win, Yadanar Hnin Si, Su Zarchi Seint, Thet Hnyn Wai Wai and many others. Furthermore, along with my former teachers Daw Aye Aye Maw, Daw Tin Tin Kyaing, Daw Chaw Chaw, Daw Khin Than Myint and Daw San Yi, I would like to express my thanks and gratitude to all my teachers from TTC for their care, guidance and support continually extended to me even after many years of my leaving from the school.

“To love is to risk not being loved in return.”
(anonymous/unknown)

Contents

1	Introduction to Cosmology	12
1.1	The Expanding Universe	12
1.2	General Relativity and Components of the Universe	14
1.3	Dark Matter	20
1.4	Dark Energy	22
1.5	Interacting Dark Energy Models	25
1.6	Alternatives to Dark Energy	29
2	Introduction to Dynamical Systems	30
2.1	Dynamical Systems	30
2.2	Linear Stability Theory	31
2.3	Lyapunov's Functions	34
2.3.1	An example of proving the stability of a critical point by finding a corresponding Lyapunov's function	35
2.4	Centre Manifold Theory	35
2.4.1	An example of application of centre manifold theory: a simple two-dimensional case	38
3	Dynamical Systems Approach to Cosmology	41
3.1	Introduction	41
3.2	Constructing a Cosmological Dynamical System	42
3.3	Incorporating Interacting Dark Energy into the Dynamical System	47
4	Models with Quadratic Couplings	50
4.1	Introduction	50
4.2	Model \mathcal{A} : $Q = \frac{\alpha}{H_0} \rho_\varphi^2$	54
4.3	Model \mathcal{B} : $Q = \frac{\beta}{H_0} \rho_c^2$	58
4.4	Model \mathcal{C} : $Q = \frac{\gamma}{H_0} \rho_c \rho_\varphi$	62
4.5	Superposition of Couplings	66
4.6	Conclusion	70

5	A Simple Model of Self-interacting Three-form and the Failure of Linear Stability Theory	72
5.1	Introduction	72
5.2	Constructing a Dynamical System for the Three-form with Simple Coupling to Dark Matter	74
5.3	Applying the Centre Manifold Theory	81
5.4	Conclusion	84
6	Interacting Phantom Dark Energy	86
6.1	Introduction	86
6.2	Phantom Dark Energy Coupled to Dark Matter with Varying-mass	87
6.3	Application of the Centre Manifold Theory to Phantom Dark Energy Model	90
6.4	Conclusion	93
7	Discussion, Future Work and Conclusion	94
7.1	Standard Model Higgs Boson Non-minimally Coupled to Gravity	94
7.1.1	Introduction	94
7.1.2	Constructing a Dynamical System and Failure of Centre Manifold Analysis	96
7.2	Einstein's Static universe	98
7.2.1	Introduction	98
7.2.2	Studying Einstein Static Universe as a Dynamical System	99
7.3	Conclusion	101

List of Figures

1	Hubble diagram from the Hubble Space Telescope Key Project. Best fit of H_0 vs distance gives the value of $72\text{km sec}^{-1} \text{Mpc}^{-1}$. Credit: Freedman <i>et al.</i> , 2001	14
2	Depiction of three possible geometries of the universe i.e. relationship between K and Ω . The top image $\Omega_{\text{tot}} > 1$ corresponds to $K > 0$ (spherical geometry). The middle image $\Omega_{\text{tot}} < 1$ corresponds to $K < 0$ (hyperbolic geometry). The bottom image $\Omega_{\text{tot}} = 1$ corresponds to $K = 0$ (flat Euclidean geometry). Credit: NASA (http://map.gsfc.nasa.gov/media/990006/index.html Accessed: 19th September 2011)	19
3	Chart showing the contents of the universe. Credit: NASA (http://map.gsfc.nasa.gov/media/060916/index.html Accessed: 7th August 2011)	21
4	Phase-space trajectories for model \mathcal{A} showing the stable node G, with $\lambda = 1.2$ and $\alpha = 10^{-3}$	56
5	Phase-space trajectories for model \mathcal{A} showing the stable focus F, with $\lambda = 2.3$ and $\alpha = 10^{-3}$	57
6	Phase-space trajectories for model \mathcal{B} showing the stable node G, with $\lambda = 1.2$ and $\beta = 10^{-3}$	60
7	Phase-space trajectories for model \mathcal{B} showing the stable focus F, with $\lambda = 2.3$ and $\beta = 10^{-3}$	61
8	Phase-space trajectories for model \mathcal{C} showing the stable node G, with $\lambda = 1.2$ and $\gamma = 10^{-3}$	64
9	Phase-space trajectories for model \mathcal{C} showing the stable focus F, with $\lambda = 2.3$ and $\gamma = 10^{-3}$	65
10	Phase-space trajectories for the superposition of couplings showing the stable node G, with $\lambda = 1.2, \alpha = 2$ and $\gamma = 2 \times 10^{-3}$	68
11	Phase-space trajectories for the superposition of couplings showing the stable focus F, with $\lambda = 2.3, \alpha = 2$ and $\gamma = 2 \times 10^{-3}$	69
12	Illustration of the movement of critical points in cases $\alpha = 0$ and a small value of α	77

13	Illustration of the movement of critical points as α value gradually increases.	78
14	Critical points at $\alpha = 3$ (left) and illustration of the movement of critical points with respect to α (right).	78
15	Trajectories in the uncoupled three-form model	79
16	Trajectories in the coupled three-form model	80
17	Dynamical behaviour of the system around the LQ critical point for the case $\Lambda > \kappa\rho_c$ with $\Lambda/\kappa = 2, w = 1$	100

List of Tables

1	Summary of the dynamical behaviour of the scale factor for different epochs of the universe	20
2	Summary of the critical points and their existence in uncoupled model.	45
3	Summary of the critical points and their stabilities.	45
4	Critical points and associated eigenvalues for coupling model \mathcal{A}	54
5	The properties of the critical points for model \mathcal{A}	55
6	Critical points and associated eigenvalues for coupling model \mathcal{B}	58
7	The properties of the critical points for model \mathcal{B}	59
8	Critical points and associated eigenvalues for coupling model \mathcal{C}	62
9	The properties of the critical points for model \mathcal{C}	63
10	Critical points and associated eigenvalues for the superposition of couplings for model \mathcal{A} and model \mathcal{C}	67
11	The properties of the critical points for the superposition of couplings.	67
12	Critical points in uncoupled case of three-form cosmology.	77
13	Critical points in the coupled case of three-form cosmology.	77
14	Critical points of the phantom dark energy model.	90

Outline

The outline of this thesis is as following: In Chapter 1, the basics of cosmology, including dark energy and its alternative, are reviewed. In Chapter 2, the mathematical machinery needed to take the dynamical systems approach to study cosmological models and its underlying theories are discussed. This is followed by Chapter 3 which reviews the role of dynamical systems in cosmology. Chapter 4 concerns with new models of coupling between quintessence dark energy and dark matter which is quadratic in their energy densities while in Chapters 5 and 6 dynamical three-form and phantom dark energy models were studied, respectively. Chapter 7 concludes the thesis with discussion on work currently in progress as well as that for the future.

1 Introduction to Cosmology

Cosmology, in simple terms, may be regarded as the study of the universe as a whole - its history, its current state, and its future. It seeks to answer the oldest questions of mankind: How did the universe come into existence? What is the universe made of? What will happen to us in the future? There are still many unanswered questions which remain subject to further scientific investigation and philosophical debate. In this thesis, the nature of a kind of mysterious contents of the universe, namely, dark energy has been studied.

1.1 The Expanding Universe

From recent observational data of Supernovae Type Ia (SNIa) in 1998, reported independently by Riess *et al* [1] and Perlmutter *et al* [2], it seems likely that our universe has been undergoing accelerated expansion (see also Reference [3]). This discovery, which subsequently led to the award of the 2011 Nobel Prize, raised many more exciting questions. Where would the energy needed to drive this possible accelerated expansion come from? One of the explanations is that a kind of energy, known as “dark energy”, may be responsible for this. Since dark energy has neither been detected nor been

understood well, it is still hypothetical and is an area of research in progress for cosmologists. Dark energy is believed to drive the universe into accelerated expansion in defiance of the known gravitationally attractive properties of the matter contents of the universe.

The acceleration could also have been due to the cosmological constant Λ term in the field equations of Einstein (see later in Chapter 2). The cosmological constant was introduced by Einstein and included in the field equations to keep the universe static, but it was later abandoned. In reality, the universe seems far from being static, it is in fact undergoing accelerated expansion. However, a positive and sufficiently large Λ can overcome the gravitational attractive force to provide repulsion, leading to an accelerating universe [4].

One of the methods to determine the expansion of the universe is by means of calculating the Doppler effect of distant objects. In 1929, Hubble observationally discovered that distant galaxies recede away from Earth and the receding velocity was found to be proportional to the relative distance of the object [5]. This becomes known as Hubble's law and is expressed as

$$v = H_0 d, \quad (1.1)$$

where v is the velocity of the receding object, H is the Hubble constant and d is the relative distance. The subscript 0 refers to today's value of the quantity concerned. Such a relationship is given by the plot in Figure 1 [6]. Objects moving towards the observer would produce blue-shifted wavelengths while those moving away from the observer would be red-shifted in the spectrum. The red-shift z of the objects moving away from observer can be expressed as

$$1 + z = \frac{\lambda_0}{\lambda}, \quad (1.2)$$

where λ is the wavelength.

The estimated value of H_0 varies: Freedman *et al* [6] estimates that $H_0 = 72 \pm 8 \text{ kms}^{-1}\text{Mpc}^{-1}$,¹ while Riess *et al* [7] estimates $H_0 = 74.2 \pm$

¹1 Parsec (Pc) is approximately 3.23 light years and 1 light year is about $1 \times 10^{16}\text{m}$.

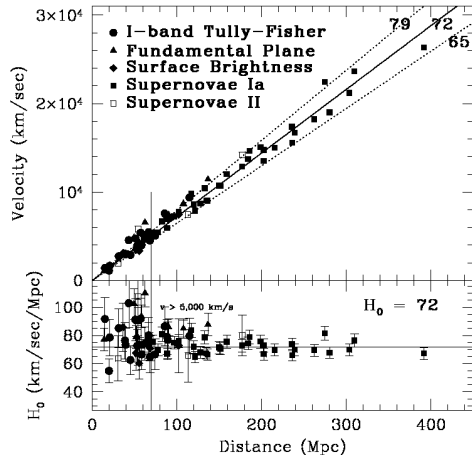

Figure 1: Hubble diagram from the Hubble Space Telescope Key Project. Best fit of H_0 vs distance gives the value of $72 \text{ km sec}^{-1} \text{ Mpc}^{-1}$. Credit: Freedman *et al.*, 2001

$3.6 \text{ km s}^{-1} \text{ Mpc}^{-1}$, while most recently, it is measured to be $67 \pm 3.2 \text{ km s}^{-1} \text{ Mpc}^{-1}$ by Beutler *et al* [8].

1.2 General Relativity and Components of the Universe

General relativity (GR) can be thought of as a geometric theory of gravitation, from which one can study the geometry of the space-time of the universe. Throughout this entire research programme, the universe is regarded as spatially flat, homogeneous and isotropic universe, known as Friedmann-Lemaître-Robertson-Walker (FLRW) universe, described by the following metric

$$ds^2 = -dt^2 + a^2(t) [dr^2 + f^2(r)d\Omega^2], \quad (1.3)$$

where

$$f(r) = \begin{cases} \sin r & \text{if } K = 1 & \rightarrow & \text{positively curved,} \\ r & \text{if } K = 0 & \rightarrow & \text{spatially flat,} \\ \sinh r & \text{if } K = -1 & \rightarrow & \text{negatively curved,} \end{cases} \quad (1.4)$$

and

$$d\Omega^2 = d\theta^2 + \sin^2 \theta d\phi^2, \quad (1.5)$$

is the metric of a 2-sphere in spherical polar coordinates. K is the spatial curvature of the universe. Since the model under assumption is a spatially flat model, the value of K is taken as 0 throughout this thesis.

Data from WMAP satellite observations [9] reveals nearly identical temperature of about 2.725 K of the Cosmic Microwave Background (CMB) radiation coming from different parts of the universe [10]. This suggests that the universe may be, at least on very large scales (> 100 Mpc), homogeneous and isotropic. Consequently, the cosmological principle, which asserts that the universe is homogeneous on large scales [11], is assumed. If the nearby environment, which contains stars, galaxies and clusters of galaxies, is to be taken into account, then the universe is highly inhomogeneous. Such inhomogeneities at local or small scales are ignored by assuming the cosmological principle. Homogeneity implies that the universe expands uniformly and hence any observer would measure the same expansion rate everywhere. Isotropy of the universe means that it looks the same in all directions and is invariant under rotations. The following axioms are also assumed:

1. The laws of physics known do not change and are the same everywhere.
2. Physical constants are true constants.
3. The universe is connected.

Matter in the Einstein field equations is described by a stress-energy tensor² $T_{\mu\nu}$. The present universe, to a good approximation, can be described

²Stress-energy tensor is also sometimes referred to as energy-momentum tensor.

by pressureless fluid or dust whose stress-energy tensor $T_{\mu\nu}$ is given by

$$T_{\mu\nu} = \rho u_\mu u_\nu, \quad (1.6)$$

where u_μ is the particle's four-velocity and ρ is the mass density of the matter³. The differential equations for the scale factor and the matter density follow from the Einstein's field equation given by [12, 13]

$$G_{\mu\nu} \equiv R_{\mu\nu} - \frac{1}{2}g_{\mu\nu}R = 8\pi GT_{\mu\nu}, \quad (1.7)$$

where $G_{\mu\nu}$ is the Einstein tensor, $R_{\mu\nu}$ is the Ricci tensor and R is the Ricci scalar, all of which depend on the metric and its derivatives. $G = 6.673 \times 10^{-11} \text{Nm}^2\text{kg}^{-1}$ is Newton's universal gravitational constant. Natural units for G and the speed of light c are used i.e. $G = c = 1$.

When the cosmological constant Λ is included, the modified Einstein's field equation becomes [13, 14]

$$R_{\mu\nu} - \frac{1}{2}g_{\mu\nu}R + \Lambda g_{\mu\nu} = 8\pi T_{\mu\nu}, \quad (1.8)$$

whose trace yields

$$R + 4\Lambda = 8\pi T. \quad (1.9)$$

The Hubble constant is related to the scale factor a by

$$H = \frac{\dot{a}}{a}. \quad (1.10)$$

Together with this, and with assumption of the perfect fluid, differentiating the Hubble constant with respect to time gives

$$\dot{H} = \frac{\ddot{a}a - \dot{a}^2}{a^2} = \frac{\ddot{a}}{a} - H^2, \quad (1.11)$$

³On cosmological scale, each galaxy is idealised as a test particle.

equation (1.8) yields

$$H^2 = \frac{8\pi}{3}\rho + \frac{\Lambda}{3} + \frac{K}{a^2}, \quad (1.12)$$

$$\dot{H} = -4\pi(p + \rho) + \frac{\Lambda}{3} + \frac{K}{a^3}, \quad (1.13)$$

$$\frac{\ddot{a}}{a} = -\frac{4\pi}{3}(\rho + 3p) + \frac{\Lambda}{3}, \quad (1.14)$$

while the continuity equation is given by

$$\dot{\rho} + 3H(\rho + p) = 0, \quad (1.15)$$

where ρ and p are the total energy density and pressure of the fluid respectively. From equations (1.12) and (1.14), it suggests that cosmological constant contributes negatively to the pressure term. It must therefore be a kind of energy with negative pressure which is in fact a property that defies the gravitational attraction.

When there is a vanishing cosmological constant and $K = 0$, and from (1.12) and (1.13), it gives

$$\frac{\ddot{a}}{a} = -\frac{4\pi}{3}(\rho + 3p), \quad (1.16)$$

from which the condition for acceleration is obtained as

$$\rho + 3p < 0, \quad (1.17)$$

and hence

$$w = \frac{p}{\rho} < -1/3. \quad (1.18)$$

Critical density ρ_{crit} is given by

$$\rho_{\text{crit}} = \frac{3H^2}{8\pi}, \quad (1.19)$$

and the density parameter Ω is defined as

$$\Omega = \frac{\rho}{\rho_{\text{crit}}}. \quad (1.20)$$

Coming back to the original equation (1.12), and dividing it by H^2 gives

$$1 = \frac{8\pi}{3H^2}\rho + \frac{\Lambda}{3H^2} - \frac{K}{a^2H^2}. \quad (1.21)$$

With the density parameters of the cosmological constant and the curvature defined respectively as

$$\Omega_\Lambda = \frac{\Lambda}{3H^2}, \quad (1.22)$$

$$\Omega_K = \frac{K}{a^2H^2}, \quad (1.23)$$

we have

$$\Omega_{\text{tot}} = \Omega + \Omega_\Lambda, \quad (1.24)$$

$$\Omega_{\text{tot}} - 1 = \frac{K}{a^2H^2} = \Omega_K. \quad (1.25)$$

From (1.24) spatial geometry of the universe is determined as

$$\Omega_{\text{tot}} > 1 \quad \text{or} \quad \rho > \rho_{\text{crit}} \quad \rightarrow \quad K = +1, \quad (1.26)$$

$$\Omega_{\text{tot}} = 1 \quad \text{or} \quad \rho = \rho_{\text{crit}} \quad \rightarrow \quad K = 0, \quad (1.27)$$

$$\Omega_{\text{tot}} < 1 \quad \text{or} \quad \rho < \rho_{\text{crit}} \quad \rightarrow \quad K = -1. \quad (1.28)$$

The geometry of the universe is spherical if $\Omega_{\text{tot}} > 1$, hyperbolic if $\Omega_{\text{tot}} < 1$, and is spatially flat Euclidean if $\Omega_{\text{tot}} = 1$. Since the value of Ω_{tot} is the density of matter present in the universe, the spatial geometry of the universe is determined by its matter distribution. As stated before, throughout this research, the universe is assumed to be spatially flat and hence the $\Omega_{\text{tot}} = 1$ case. This assumption, in fact, seems consistent with reality as suggested by observations which have shown that the current state of universe is such that the value of Ω_{tot} is very close to 1 [15].

Then, by solving the Friedmann equation, one obtains the solution for the scale factor $a(t)$ which represents the dynamics of the universe and it turns out that for dust-dominated universe with the value of the equation of

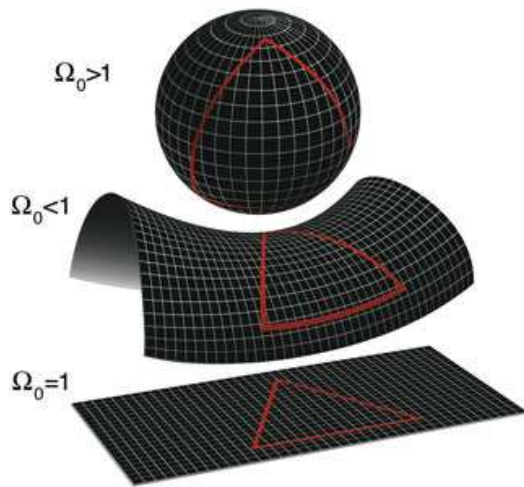

Figure 2: Depiction of three possible geometries of the universe i.e. relationship between K and Ω . The top image $\Omega_{\text{tot}} > 1$ corresponds to $K > 0$ (spherical geometry). The middle image $\Omega_{\text{tot}} < 0$ corresponds to $K < 1$ (hyperbolic geometry). The bottom image $\Omega_{\text{tot}} = 1$ corresponds to $K = 0$ (flat Euclidean geometry). Credit: NASA (<http://map.gsfc.nasa.gov/media/990006/index.html> Accessed: 19th September 2011)

state $w = 0$ [14],

$$a(t) \propto (t - t_0)^{2/3}, \quad \rho \propto a^{-3}, \quad (1.29)$$

while for radiation-dominated universe with $w = 1/3$, the solution is

$$a(t) \propto (t - t_0)^{1/2}, \quad \rho \propto a^{-4}. \quad (1.30)$$

For matter-dominated universe, $\rho \propto \frac{1}{a^3}$ is expected as $\rho \propto \frac{1}{V}$ and $a^3 \propto V$, where V is the volume. In the radiation-dominated universe, the energy E of the photons is lost as the universe expands as $E \propto \frac{1}{a}$. The number density, as in the matter-dominated universe, is proportional to $\frac{1}{a^3}$. Together with this, in the radiation-dominated universe, there is an extra-factor of a^{-1} in the relationship between energy density and scale factor. The dynamical behaviour of the scale factor for different epochs of the universe is summarised in Table 1.

Measuring how the scale factor changes, therefore, reveals the energy

Epoch	Dynamical behaviour of the scale factor
inflation	$a \propto \exp(\lambda t)$ (model-dependent and λ is a constant)
matter	$a \propto t^{2/3}$
radiation	$a \propto t^{1/2}$
dark energy	$a \propto \exp(\sqrt{\frac{\Delta}{3}}t)$

Table 1: Summary of the dynamical behaviour of the scale factor for different epochs of the universe

contents of the universe. Cosmic inflation takes place in the early era universe prior to radiation-dominated epoch. We are interested in late-time era of the universe dominated by dark energy. Therefore, radiation has been neglected in this thesis.

1.3 Dark Matter

Regarding the contents of the universe, it has been known that only about 4% of the universe is the observed ordinary matter such as atoms, while the dark matter is believed to make up about 22% of it. The rest is filled with so-called dark energy whose nature is still unknown. The existence of dark matter has long been implied from the flattened galactic rotation curves [16] observed by Zwicky [17, 18] as early as 1933 (although modified Newtonian dynamics or modified gravity may be an alternative explanation). Dark matter does not interact with normal matter or electromagnetic radiation. It perhaps interacts only gravitationally. Therefore, so far, it has not been possible to detect dark matter directly. Only the total dark sector energy-momentum tensor is inferred from its combined gravitational effect on visible matter. One of the indirect methods of detecting it is, amongst others, by means of gravitational lensing (see e.g. [19] and references therein). The search for candidate dark matter particles is still in progress (see e.g. [20–23]). Possible candidate particles or models includes, but are not limited to, axions, neutrinos, neutralinos and so on. Ordinary matter is referred to as baryonic matter or baryons and quantities related to them are indicated with subscript b . They are protons and neutrons, but for cosmological purpose, electrons

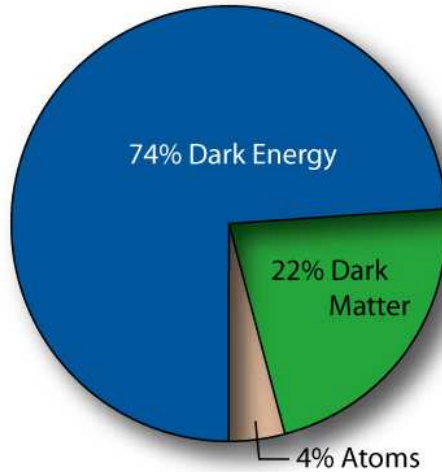

Figure 3: Chart showing the contents of the universe. Credit: NASA (<http://map.gsfc.nasa.gov/media/060916/index.html> Accessed: 7th August 2011)

are also included in the baryons. It could also include baryonic dark matter which may be detected by means of gravitational lensing. Dark matter may also be non-baryonic. This possibility is also inferred from the event where atomic nuclei were formed in the early stage of the universe. This process is called nucleosynthesis.

Dark matter is considered essential in the formation and growth of large-scale structures in the universe such as galaxies and clusters of galaxies. It has been predicted by particle physicists that the dark matter particles must be very massive in order for its properties to be consistent with respect to the structure formation in the universe [24]. Weakly interacting particles, including dark matter and its candidate particles, are collectively classed as Weakly Interacting Massive Particles (WIMPs).

Dark matter can be classified into different families: one of them is the cold dark matter (CDM) for non-relativistic dark matter which have no significant random motion, and another one is called hot dark matter (HDM) which is relativistic. The former is a simple model since individual particle properties are, by definition, not important and their density Ω is the only

important quantity. CDM may be considered extremely important since it is said to incorporate dark matter with evolution of structure and inflation that are beyond the Standard Model [13]. There is yet another type of dark matter model known as warm dark matter (WDM), cosmological effects of which depend both on density and the nature of random motion and are therefore considered more complex. The CDM candidates may be some kind of lightest supersymmetric particles or massive primordial black holes while neutrinos may be the possible candidates of HDM. Active experimental efforts have been made to search for neutrinos as one possible candidate (see e.g. [25] and references therein).

1.4 Dark Energy

The current best fit in the Hubble’s diagram seems to imply a preference for a universe with more than 70% of the energy in the form of dark energy [13], for which reason investigating a universe with a scenario in which it is dominated by dark energy appears important. The idea of dark energy, however, is hypothetical since it has never been detected or created in a laboratory.⁴ It has been introduced to explain the observed accelerated expansion of the universe. Furthermore, at this stage, it is necessary to include the concept of dark energy in order to account for the vast majority of missing energy in the universe, which otherwise would lead to a “shortfall” of the energy budget of the universe. One of the simplest models for dark energy is the cosmological constant Λ or vacuum energy density, with negative pressure, whose equation of state is given by

$$w_\Lambda = \frac{p_\Lambda}{\rho_\Lambda} = -1, \quad (1.31)$$

where p_Λ and ρ_Λ are the pressure and the energy density of the cosmological constant respectively.

Λ is also called the vacuum energy density since, in particle physics, it

⁴Analogical phenomena may be observed in a kind of superfluid condensate known as Bose-Einstein Condensate which exhibits behaviour analogous to accelerated expansion of the universe [26].

naturally arises as the energy density of the vacuum. The fact that it has negative pressure distinguishes dark energy from other kinds of matter such as baryons and radiation, which are also constituents of the universe. Originally, the cosmological constant was introduced by Einstein and included in his field equations of general relativity to keep the universe static. However, it later turned out that the cosmological constant itself can be regarded as a form of dark energy that is driving the late-time acceleration of the universe.

The standard model of cosmology, known as Λ CDM (cold dark matter) model, is a very good model that is in good agreement with observational data. However, there exists several fine-tuning problems, one of which is that the value of Λ is many orders of magnitude smaller than that of the vacuum energy predicted in quantum field theories. It is severely fine-tuned and is the order of about 10^{121} wrong. The observational value of dark energy is expected to be about 10^{74} GeV while the vacuum energy is approximately 10^{-47} GeV. This problem is called the cosmological constant problem (for recent review, see e.g. [27, 28]). It has not been resolved satisfactorily until today.

It has been considered that if dark energy evolves with time, the cosmological coincidence problem may be alleviated. One of the simplest scalar field models of time-evolving dark energy is quintessence [29, 30] which is one of the main investigations of this thesis. Some other models of dark energy are scalar field models such as phantom fields [31], K-essence [32–34], tachyons [35, 36], Chaplygin gases [37–39], and Higgs fields amongst others. A review on various dark energy models can be found in [14] and references therein. In theoretical particle physics and string theory, scalar fields naturally arise. It may, therefore, be possible for them to act as potential candidates of dark energy. There are also more complicated fields proposed as dark energy models such like as p -forms, spinors [40, 41] and vector fields [42]. Each model has its own strengths and shortcomings.

The cosmological constant problem is not the only problem that the standard model of cosmology suffers from, there are also other problems, namely the flatness problem and the horizon problem.

Flatness problem

By recalling that we have

$$\Omega_{\text{tot}} - 1 = \frac{K}{(aH)^2},$$

which is time-dependent in general. However, if the constant time hypersurfaces are flat i.e. $K = 0$, then $\Omega_{\text{tot}} = 1$ and it remains so for all times. In a flat matter-dominated universe,

$$a \sim t^{2/3}, \quad H \sim \frac{1}{t} \quad \Rightarrow \quad aH \sim t^{-1/3}, \quad (1.32)$$

while for radiation-dominated epoch,

$$a \sim t^{1/2}, \quad H \sim \frac{1}{t} \quad \Rightarrow \quad aH \sim t^{-1/2}, \quad (1.33)$$

hence arriving at

$$|\Omega_{\text{tot}} - 1| \sim \begin{cases} t & \text{radiation-dominated;} \\ t^{2/3} & \text{matter-dominated.} \end{cases} \quad (1.34)$$

The flatness problem is that in general aH is a decreasing function. The value of Ω_{tot} at time $t = 0$ is of the order of unity. Thus it is expected that Ω has to be close to unity at earlier times. For example, it is required that, at time $t = t_{\text{nucleo}}$ when nucleosynthesis takes place, $|\Omega(t_{\text{nucleo}})| < \mathcal{O}(10^{-16})$, and in Planck epoch⁵ at time $t = t_{\text{Planck}}$, $|\Omega(t_{\text{Planck}})| < \mathcal{O}(10^{-64})$, in order to obtain the universe as it is at present. These are highly fine-tuned conditions and are unlikely. Without these fine-tuned conditions the universe would either collapse too soon, or expand too quickly before structure formation.

⁵Planck epoch is when the universe is only at the age of Planck time, which is about 10^{-43} s. This is before inflation.

Horizon problem

The particle horizon D_H is the distance travelled by light since the beginning of the universe at time $t = t_0$ and is defined as

$$D_H = ad_H, \quad (1.35)$$

where

$$d_H = \int_{t_0}^t \frac{dt'}{a(t')}, \quad (1.36)$$

is the comoving distance. Both in radiation- and matter-dominated epochs, there are particle horizons and there exist regions that cannot interact. On the other hand, the cosmic microwave background (CMB) radiation is nearly homogeneous i.e. it has roughly the same temperature distribution in all directions on the sky. These are the regions that cannot have interacted before recombination⁶. Thus, the question arises as to how it was possible to achieve thermal equilibrium if there were no interactions between these regions. Such a problem is called horizon problem.

In order to overcome these problems, the concept of cosmological inflation [43] needs to be considered. It is an epoch in which the scale factor of the universe undergoes extremely rapid exponential expansion. The hypothetical field that is responsible for inflation to take place is called inflaton. There exist various inflationary models (see e.g. [44] and references there in).

1.5 Interacting Dark Energy Models

Since neither dark energy nor dark matter are understood fundamentally, currently there are no *a priori* conditions imposed upon possible interactions between these two components. Therefore, without violating the observational constraints, dark energy may interact with dark matter in various fashions by means of energy transfer between each other. If dark energy interacts with dark matter, then the former would also have some role in the past history of the universe, in particular, structure formation. In contrast, in the

⁶Recombination refers to an epoch in which electrons and nucleons combine to form atoms. Before this, the universe was too hot for the atomic nuclei to be formed.

uncoupled models, dark energy only become important at late times. During the early stage of the universe, it was dominated by radiation, and then by matter. The present universe or late universe appears to be dominated by dark energy.

The coupling strength of the coupling models may be varied to be in agreement with observations of Cosmic Microwave Background (CMB) and galaxy clustering. The interaction between dark energy and dark matter has never been observed or created in laboratory, nor is there a well-grounded theory that implies a specific form of coupling and therefore any such coupling models will necessarily be phenomenological and the aim is to work out a more realistic model with better physical justification. However, experimental activities are taking place to explore the relationship between dark matter and dark energy such like as those carried out at Large Hadron Collider (LHC) at CERN in Switzerland [45].

There is plenty of literature on this matter and various models have been investigated (see, for example, [46–62] and references therein). Some models are motivated by mathematical simplicity, while other may feature more interesting and realistic properties.

As mentioned earlier, we wish to alleviate the cosmological coincidence problem in which the Λ CDM model is highly fine-tuned due to the fact that dark matter energy density is comparable to the vacuum or dark energy density yet their time evolution is so different. A decisive way of achieving similar energy densities is if the couplings can lead to an accelerated scaling attractor solution with

$$\frac{\Omega_{\text{darkenergy}}}{\Omega_{\text{darkmatter}}} = \mathcal{O}(1) \quad \text{and} \quad \ddot{a} > 0. \quad (1.37)$$

Based on the fact that dark energy and dark matter have the same order of energy density today, it is reasonable to assume that there may be some form of interaction or relation between them. Therefore the above expression is a well-motivated scaling solution intended to alleviate cosmological coincidence problem. In fact, certain types of interaction such like as those taking place in the form of $Q = \beta\rho_m\dot{\varphi}$ [46, 47, 63] also appear in scalar-tensor the-

ories, $f(R)$ gravity and dilaton gravity (see e.g. [64] and references therein). Furthermore, coupling can lead to an accelerated scaling attractor solution such that the need for fine-tuned initial conditions can be eliminated from context [56, 65].

In the models investigated in this thesis, scalar fields with exponential potential [29, 30, 66] have been considered. There is also literature that considered other forms of scalar field potentials. An expression for general interaction between a scalar field φ , that contains dark energy, and dark matter is given by [14, 64]

$$\nabla_\mu T_{\nu(\varphi)}^\mu = -Q_\nu, \quad (1.38)$$

$$\nabla_\mu T_{\nu(M)}^\mu = Q_\nu. \quad (1.39)$$

where $\nabla_\mu T_{\nu(\varphi)}^\mu$ and $\nabla_\mu T_{\nu(M)}^\mu$ are the energy-momentum tensors of the scalar field φ and non-relativistic matter, respectively, which can be known from its combined gravitational effect. In order to separate the two components, it is necessary to assume a model for them. It is possible that the interaction between these two components takes place without being coupled to standard model particles (such like as baryons). The trace of $T_{\nu(M)}^\mu$ yields

$$T_M = -\rho_M + 3P_M, \quad (1.40)$$

of the matter fluid.

In this thesis, radiation has been neglected since the primary interest is in the dark sector. Furthermore, baryons are assumed to be decoupled so that they are unaffected by any force other than gravity, hence to ensure that the results obtained are comparable to that of observations.

The energy conservation equations in the case of general coupling Q become

$$\dot{\rho}_\varphi + 3H(\rho_\varphi + P_\varphi) = -Q, \quad (1.41)$$

$$\dot{\rho}_M + 3H\rho_M = Q. \quad (1.42)$$

For the sake of completeness, we state the other evolution equations for baryons and radiation which are given by

$$\dot{\rho}_b + 3H\rho_b = 0, \quad (1.43)$$

$$\dot{\rho}_r + 4H\rho_r = 0. \quad (1.44)$$

In what follows, the presence of ρ_b and ρ_r will be neglected in our models. It follows that

$$Q \begin{cases} > 0 & \text{energy transfer is dark matter} \rightarrow \text{dark energy;} \\ < 0 & \text{energy transfer is dark energy} \rightarrow \text{dark matter.} \end{cases} \quad (1.45)$$

The dark energy equation of state parameter is

$$w_\varphi := \frac{p_\varphi}{\rho_\varphi} = \frac{\frac{1}{2}\dot{\varphi}^2 - V(\varphi)}{\frac{1}{2}\dot{\varphi}^2 + V(\varphi)}, \quad (1.46)$$

The modified Klein-Gordon equation becomes

$$\ddot{\varphi} + 3H\dot{\varphi} + \frac{dV}{d\varphi} = \frac{Q}{\dot{\varphi}}. \quad (1.47)$$

and

$$\dot{H} = -\frac{\kappa^2}{2} \left[\rho_c + \rho_b + \frac{4}{3}\rho_r + \dot{\varphi}^2 \right], \quad (1.48)$$

subject to the Friedman constraint,

$$\Omega_c + \Omega_b + \Omega_r + \Omega_\varphi = 1, \quad \Omega := \frac{\kappa^2 \rho_i}{3H^2} \quad \text{with } i = c, b, r, \varphi. \quad (1.49)$$

However, in this case baryons are considered to be decoupled and radiation in the dark sector. Effective equation of state parameters for the dark sector are defined by

$$w_{c,\text{eff}} = \frac{Q}{3H\rho_c}, \quad w_{\varphi,\text{eff}} = w_\varphi - \frac{Q}{3H\rho_\varphi}. \quad (1.50)$$

Consequently,

$$Q > 0 \Rightarrow \begin{cases} w_{c,\text{eff}} > 0 & \text{dark matter redshifts faster than } a^{-3}; \\ w_{\varphi,\text{eff}} < w_{\text{de}} & \text{dark energy has more accelerating power.} \end{cases} \quad (1.51)$$

$$Q < 0 \Rightarrow \begin{cases} w_{c,\text{eff}} < 0 & \text{dark matter redshifts slower than } a^{-3}; \\ w_{\varphi,\text{eff}} > w_{\text{de}} & \text{dark energy has less accelerating power.} \end{cases} \quad (1.52)$$

1.6 Alternatives to Dark Energy

Since existence of dark energy has not yet been proved, it may be possible to find alternative theories that can explain the observed accelerated expansion of the universe, while at the same time solving the cosmological constant problem. Some of such theories are modified gravity theories known as $f(R)$ [67, 68] and $f(T)$ [69] theories, a network of topological defects driving the universe into a period of accelerated expansion [70], quantum gravity [71], string theory [72] and so on. This list is not exhaustive. Some reviews on recent progresses in the context of $f(R)$ gravity theories can be found in [73]. Investigation of these theories are beyond the scope of this thesis.

2 Introduction to Dynamical Systems

The aim of this chapter is to discuss some mathematical aspects of dynamical systems, or systems of autonomous differential equations. Autonomous systems are the ones which do not explicitly depend on time, while non-autonomous systems are the systems in which the time variable does not explicitly appear in the differential equation(s) describing the system, for example, a forced damped pendulum equation [74]. In Chapter 3, we will discuss the role of dynamical systems in cosmology.

2.1 Dynamical Systems

What is a dynamical system? It can be anything ranging from something as simple as a single pendulum to as complex as human brain and the entire universe itself. A dynamical system consists of

1. a space (state space or phase space), and
2. a mathematical rule describing the evolution of any point in that space.

The state of the system is a set of quantities which are considered important about the system and the state space is the set of all possible values of these quantities. In the case of a pendulum, position and momentum are natural quantities to specify the state of the system. For more complicated systems such as those in cosmology, the choice of good quantities is not obvious and it turns out to be useful to choose convenient variables.

There are two main types of dynamical systems. The first one is the continuous dynamical systems whose evolution is defined by ordinary differential equations (ODEs) and the other one is called time-discrete dynamical systems which are defined by a map or difference equations. In this PhD programme the systems under investigation are called autonomous systems which fall under the category of continuous dynamical systems.

The standard form of a dynamical system is usually expressed as [75]

$$\dot{\mathbf{x}} = \mathbf{f}(\mathbf{x}), \tag{2.1}$$

where $\mathbf{x} \in X$ i.e. \mathbf{x} is an element in state space $X \subset \mathbb{R}^n$, and $\mathbf{f} : X \rightarrow X$. The function $\mathbf{f} : \mathbb{R}^n \rightarrow \mathbb{R}^n$ is a vector field on \mathbb{R}^n such that

$$\mathbf{f}(\mathbf{x}) = (f_1(x), \dots, f_n(x)), \quad (2.2)$$

and $\mathbf{x} = (x_1, x_2, \dots, x_n)$.

These ODEs define the vector fields of the system. At any point $x \in X$ and any particular time t , $\mathbf{f}(\mathbf{x})$ defines a vector field in \mathbb{R}^n . As far as this PhD thesis is concerned, the systems under investigation are finite dimensional and continuous autonomous systems.

Definition (*Critical point*) The autonomous equation $\dot{x} = f(x)$ is said to have a critical point or fixed point at $x = x_0$ if and only if $f(x_0) = 0$.

The stability/instability of a fixed point may be categorised as following: A critical point $(x, y) = (x_0, y_0)$ is stable (also called Lyapunov stable) if all solutions $x(t)$ starting near it stay close to it and asymptotically stable if it is stable and the solutions approach the critical point for all nearby initial conditions. If the point is unstable then solutions will escape away from it. The stability/instability of the fixed points may also be revealed by means of linearisation.

2.2 Linear Stability Theory

Given a dynamical system $\dot{x} = f(x)$ with critical point at $x = x_0$, in order to linearise the system it should first be Taylor expanded such that

$$f(x) \approx f(x_0) + \frac{f'(x_0)}{1!}(x - x_0) + \frac{f''(x_0)}{2!}(x - x_0)^2 + \dots, \quad (2.3)$$

which can be generalised as

$$f(x) \approx \sum_{n=0}^{\infty} \frac{f^{(n)}(x_0)}{n!}(x - x_0)^n. \quad (2.4)$$

By the definition of the critical point, $f(x_0) = 0$ and by ignoring the higher order terms,

$$\dot{x} = f'(x_0)(x - x_0). \quad (2.5)$$

In this setup, the critical point x_0 can be deduced as

1. stable if $f'(x_0) < 0$,
2. unstable if $f'(x_0) > 0$,
3. unknown i.e. linear stability theory fails if $f'(x_0) = 0$.

If the linearisation results in the case 3 above, then non-linear stability analysis must be performed. The above was a 1D system. For higher dimensional systems, eigenvalues of the Jacobi matrix of the system evaluated at critical points would reveal information regarding their stabilities. Given a dynamical system $\dot{x} = f(x, t)$ with critical point at $x = x_0$, the system is linearised about its critical point by

$$\mathcal{M} = Df(x_0) = \left(\frac{\partial f_i}{\partial x_j} \right)_{x=x_0}, \quad (2.6)$$

and the matrix \mathcal{M} is called Jacobi matrix.

For example, a simple 2D autonomous system, may be given by

$$\begin{aligned} \dot{x} &= f(x, y), \\ \dot{y} &= g(x, y), \end{aligned} \quad (2.7)$$

where f and g are functions of x and y , with critical point at $(x = x_0, y = y_0)$ assumed. The Jacobi matrix constructed to linearise the system about its critical point would then be

$$\mathcal{M} = \begin{pmatrix} \frac{\partial f}{\partial x} & \frac{\partial f}{\partial y} \\ \frac{\partial g}{\partial x} & \frac{\partial g}{\partial y} \end{pmatrix}. \quad (2.8)$$

When eigenvalues are computed, it will have two eigenvalues, hereby denoted by λ_1 and λ_2 . The eigenvalues of this matrix linearised about the

critical point in question reveal the stability/instability of that point provided that the point is hyperbolic.

Definition Let $x = x_0$ be a fixed point (critical point) of the system $\dot{x} = f(x)$, $x \in \mathbb{R}^n$. Then x_0 is said to be hyperbolic if none of the eigenvalues of $Df(x_0)$ have zero real part, and non-hyperbolic otherwise [75].

If the point is non-hyperbolic, linear stability theory fails and therefore alternative techniques such as finding Lyapunov's functions or applying centre manifold theory must be carried out.

Assuming a general 2D system, the possibilities regarding the stability of the critical point with respect to the two eigenvalues λ_1 and λ_2 are as follows:

1. If $\lambda_1 < 0$ and $\lambda_2 < 0$, then the critical point of the dynamical system is asymptotically stable and trajectories starting near that point will approach that point or remain near that point.
2. If $\lambda_1 > 0$ and $\lambda_2 > 0$, then the critical point of the dynamical system is unstable and trajectories will escape away.
3. If $\lambda_1, \lambda_2 \neq 0$ and are of opposite signs, then the critical point is a saddle.
4. If $\lambda_1 = 0$ and $\lambda_2 > 0$, or the other way round, the point is unstable.
5. If $\lambda_1 = 0$ and $\lambda_2 < 0$, or the other way round, it is not possible to tell whether the critical point is stable or unstable. The point is non-hyperbolic. In the chapters that follow, how nature of stability of non-hyperbolic points can be determined will be reviewed.
6. If $\lambda_1 = \alpha + i\beta$ and $\lambda_2 = \alpha - i\beta$, with $\alpha > 0$ and $\beta \neq 0$, it is an unstable spiral.
7. If $\lambda_1 = \alpha + i\beta$ and $\lambda_2 = \alpha - i\beta$, with $\alpha < 0$ and $\beta \neq 0$, it is a stable spiral.
8. If $\lambda_1 = i\beta, \lambda_2 = -i\beta$, then the solutions are oscillatory and is a centre⁷.

⁷Note that a critical point being a centre is not related to centre manifolds.

2.3 Lyapunov's Functions

Lyapunov's functions, named after the Russian mathematician Aleksandr Mikhailovich Lyapunov, are functions that can be used to prove the stability of the critical points of the system. In constructing Lyapunov's functions, a number of conditions must be satisfied. Unfortunately, there is no systematic way of finding these functions. They are, at best, done by trial and error and by educated guess. Traditionally, Lyapunov's functions have played a key role in control theory, but there have also been some work in which it has been applied in cosmological contexts [76, 77].

Definition (*Lyapunov function*) Given a smooth dynamical system $\dot{x} = f(x)$, $x \in \mathbb{R}^n$, and an critical point x_0 , a continuous function $V : \mathbb{R}^n \rightarrow R$ in a neighbourhood U of x_0 is a Lyapunov function for the point if

1. V is differentiable in $U \setminus \{x_0\}$,
2. $V(x) > V(x_0) \quad \forall x \in U \setminus \{x_0\}$,
3. $\dot{V} \leq 0 \quad \forall x \in U \setminus \{x_0\}$.

The existence of a Lyapunov's function guarantee the asymptotic stability and one would not have to solve the ODEs explicitly. However, just because it was not possible to compute Lyapunov's function at a particular point does not necessarily imply that such a point is unstable. Since there is no systematic way of finding the function, it is possible that one could not simply construct a Lyapunov's function for the critical point concerned.

Theorem 2.1 (Lyapunov stability) *Let x_0 be a critical point of the system $\dot{x} = f(x)$, where $f : U \rightarrow \mathbb{R}^n$ and $U \subset \mathbb{R}^n$ is a domain that contains x_0 . If V is a Lyapunov function, then*

1. *if $\dot{V} = \frac{\partial V}{\partial x} f$ is negative semi-definite, then $x = x_0$ is a stable fixed point,*
2. *if $\dot{V} = \frac{\partial V}{\partial x} f$ is negative definite, then $x = x_0$ is an asymptotically stable fixed point.*

Furthermore, if $\|x\| \rightarrow \infty$ and $V(x) \rightarrow \infty$ for $\forall x$, then x_0 is said to be globally stable or globally asymptotically stable, respectively.

2.3.1 An example of proving the stability of a critical point by finding a corresponding Lyapunov's function

In the subsequent work where attempts were made to find the Lyapunov's function of the critical points, the following example from [75] has been closely followed. Suppose that a system is described by the vector field

$$\dot{x} = y, \tag{2.9}$$

$$\dot{y} = -x + \epsilon x^2 y, \tag{2.10}$$

which has a critical point at $(x, y) = (0, 0)$. A candidate Lyapunov's function is given by

$$V(x, y) = \frac{x^2 + y^2}{2}, \tag{2.11}$$

satisfying $V(0, 0) = 0$ and $V(x, y) > 0$. This function leads to

$$\dot{V}(x, y) = \nabla V(x, y) \cdot (\dot{x}, \dot{y}) = \epsilon x^2 y^2, \tag{2.12}$$

from which it can be concluded that the point is stable if $\epsilon < 0$ since it would give $\dot{V} < 0$. It is important to emphasise, however, that $\epsilon > 0$ does not imply the point is unstable.

2.4 Centre Manifold Theory

Centre manifold theory is a theory that allows us to simplify the dynamical systems by reducing their dimensionality. It is also central to other elegant theories such as bifurcations. Another technique that can also be applied to simplify the dynamical systems is the method of normal forms which eliminates the nonlinearity of the system. Here the essential basics of the theory are discussed. The eigenspace with corresponding eigenvalues that have zero real parts reveals little information about the system. As a result, where there is a zero eigenvalue resulting from the Jacobi matrix, the corresponding critical point is non-hyperbolic and the structural stability is no longer guaranteed. Thus, it is necessary to investigate further by, for example, applying the centre manifold theory.

In applying the centre manifold theory, the approach taken by Wiggins [75] has been closely followed.

Let a dynamical system be represented by the vector fields as followings:

$$\begin{aligned}\dot{x} &= Ax + f(x, y), \\ \dot{y} &= By + g(x, y), \quad (x, y) \in \mathbb{R}^c \times \mathbb{R}^s,\end{aligned}\tag{2.13}$$

where

$$\begin{aligned}f(0, 0) &= 0, & Df(0, 0) &= 0, \\ g(0, 0) &= 0, & Dg(0, 0) &= 0,\end{aligned}\tag{2.14}$$

are \mathbf{C}^r functions.

In the system (2.13), A is a $c \times c$ matrix possessing eigenvalues with zero real parts, while B is an $s \times s$ matrix whose eigenvalues have negative real parts. The aim is to compute the centre manifold of these vector fields so as to investigate the dynamics of the system.

Definition (*Centre Manifold*) A geometrical space is a centre manifold for (2.13) if it can be locally represented as

$$W^c(0) = \{(x, y) \in \mathbb{R}^c \times \mathbb{R}^s \mid y = h(x), |x| < \delta, h(0) = 0, Dh(0) = 0\},\tag{2.15}$$

for δ sufficiently small.

The conditions $h(0) = 0$ and $Dh(0) = 0$ from the definition imply that $W^c(0)$ is tangent to the eigenspace E^c at the critical point $(x, y) = (0, 0)$.

In applying the centre manifold theory, three main theorems [75], each for existence, stability and approximation, have been assumed without proof.

Theorem 2.2 (Existence) *There exist a \mathbf{C}^r centre manifold for (2.13). Its dynamics restricted to the centre manifold is given by*

$$\dot{u} = Au + f(u, h(u)), \quad u \in \mathbb{R}^c,\tag{2.16}$$

for u sufficiently small.

Theorem 2.3 (Stability) *Suppose the zero solution of (2.16) is stable (asymptotically stable) (unstable); then the zero solution of (2.16) is also stable (asymptotically stable) (unstable). Furthermore, if $(x(t), y(t))$ is also a solution of (2.16) with $(x(0), y(0))$, there exists a solution $u(t)$ of (2.16) such that*

$$x(t) = u(t) + \mathcal{O}(e^{-\gamma t}), \quad (2.17)$$

$$y(t) = h(u(t)) + \mathcal{O}(e^{-\gamma t}), \quad (2.18)$$

as $t \rightarrow \infty$, where $\gamma > 0$ is a constant and for sufficiently small $(x(0), y(0))$.

In order to proceed to compute the centre manifold and before stating or considering the third theorem, an equation that $h(x)$ must satisfy, in order that its graph to be a centre manifold for (2.13), needs to be derived. Its explicit derivation is as following.

First, by the chain rule, differentiating $y = h(x)$ gives

$$\dot{y} = Dh(x)\dot{x}, \quad (2.19)$$

and is satisfied by any (\dot{x}, \dot{y}) coordinates of any point on $W^c(0)$ since (x, y) coordinates of any point on it must have satisfied $y = h(x)$.

Furthermore, $W^c(0)$ obeys the dynamics generated by the system (2.13). Substituting

$$\dot{x} = Ax + f(x, h(x)), \quad (2.20)$$

$$\dot{y} = Bh(x) + g(x, h(x)), \quad (2.21)$$

into (2.19) yields

$$Dh(x) [Ax + f(x, h(x))] = Bh(x) + g(x, h(x)), \quad (2.22)$$

and re-arranging this results in quasilinear partial different equation \mathcal{N} given by

$$\mathcal{N}(h(x)) \equiv Dh(x) [Ax + f(x, h(x))] - Bh(x) + g(x, h(x)) = 0, \quad (2.23)$$

and must be satisfied by $h(x)$ so as to ensure its graph to be an invariant manifold.

Finally the following third and last theorem is assumed in computing the approximate solution of (2.23).

Theorem 2.4 (Approximation) *Let $\phi : \mathbb{R}^c \rightarrow \mathbb{R}^s$ be a \mathbf{C}^1 mapping with $\phi(0) = D\phi(0) = 0$ such that $\mathcal{N}(\phi(x)) = \mathcal{O}(|x|^q)$ as $x \rightarrow 0$ for some $q > 1$. Then*

$$|h(x) - \phi(x)| = \mathcal{O}(|x|^q) \quad \text{as} \quad x \rightarrow 0. \quad (2.24)$$

The advantage of this theorem is that one can compute the centre manifold which would return the same degree of accuracy as solving (2.23) but without having to face the difficulties associated with doing it. The proofs of these theorems can be found in Carr [78].

2.4.1 An example of application of centre manifold theory: a simple two-dimensional case

The following two dimensional example from Wiggins [75] has been closely followed and extended in applying the centre manifold theory to study the cosmological problems. Suppose there is a system given by the vector field

$$\begin{aligned} \dot{x} &= x^2y - x^5, \\ \dot{y} &= -y + x^5, \quad (x, y) \in \mathbb{R}^2. \end{aligned} \quad (2.25)$$

The origin, $(x, y) = (0, 0)$ is a critical points, which yields, when linearised about it, eigenvalues of 0 and -1 . Since there is a zero eigenvalue, it is not possible to determine the nature of stability of this point just by looking at the eigenvalues obtained from the Jacobi matrix evaluated at that point. The point is non-hyperbolic and therefore structural stability is no longer guaranteed. Thus, non-linear stability analysis must be performed and this is where centre manifold theory can be applied.

As per Theorem 2.2, there exists a centre manifold for the system (2.25)

and it can be represented locally as:

$$W^c(0) = \{(x, y) \in \mathbb{R}^2 \mid t = h(x), |x| < \delta, h(0) = Dh(0) = 0\}, \quad (2.26)$$

for δ sufficiently small.

In order to proceed with computing the $W^c(0)$, it is customary to assume the expansion for $h(x)$ to be of the form

$$h(x) = a_1x^2 + a_2x^3 + \mathcal{O}(x^4), \quad (2.27)$$

and it is then substituted into (2.23) which, in order for it to be a centre manifold, must be satisfied by $h(x)$.

In this example,

$$\begin{aligned} A &= 0, \\ B &= -1, \\ f(x, y) &= x^2y - x^5, \\ g(x, y) &= x^2. \end{aligned} \quad (2.28)$$

which, together with (2.27), is substituted into (2.23), gives

$$\begin{aligned} \mathcal{N} &= (2ax + 3bx^2 + \dots)(ax^4 + bx^5 - x^5 + \dots) \\ &+ ax^2 + bx^3 - x^2 + \dots = 0. \end{aligned} \quad (2.29)$$

The coefficients of each power of x must be zero so that (2.29) holds. Then coefficients of each power of x are equated to zero, so that for x^2 and x^3 ,

$$\begin{aligned} a &= 1, \\ b &= 0, \end{aligned} \quad (2.30)$$

respectively and the higher powers are ignored. Therefore,

$$h(x) = x^2 + \mathcal{O}(x^4). \quad (2.31)$$

Finally, as per Theorem 2.2, the dynamics of the system restricted to the centre manifold is obtained to be

$$\dot{x} = x^4 + \mathcal{O}(x^5). \tag{2.32}$$

By studying (2.32), it can be concluded that for x sufficiently small, $x = 0$ is unstable. Therefore, the critical point $(0, 0)$ is unstable.

3 Dynamical Systems Approach to Cosmology

3.1 Introduction

As defined earlier, a dynamical system, in simple terms, is nothing but a mathematical concept in which a fixed rule determines the evolution and state of a system in future. A dynamical system is described by an equation of the form

$$\dot{x} = f(x). \tag{3.1}$$

In equation (3.1), for simplicity t was not included as a variable in the function since the system is assumed to be autonomous. Many processes and systems that are of cosmological interest can be modelled as a dynamical system of that form. The motivation is to re-write Einstein's field equations for cosmological models in terms of a system of autonomous first-order ODEs, thereby modelling it as a dynamical system in \mathbb{R}^n [64].

It is a powerful tool which allows one to study the dynamical behaviour of the universe as a whole. By analysing the fixed points (critical points) at which $f(x)$ vanishes, it often suffices to extract information regarding the dynamics of the universe. In doing so, the following three requirements must be met:

1. There has to be an early time expansion (inflation), a state which should be unstable so as to enable the universe to evolve away from that point.
2. An epoch of matter domination is required since it would not be possible for us to exist otherwise.
3. A late-time attractor where the universe expands must exist. This is in order to resemble the current state of the universe which, according to observational data, is undergoing accelerated expansion and asymptotically approaching de Sitter space.

With this established, a dynamical system approach incorporating cosmological quantities fulfilling the above requirements has been taken in studying the interacting dark energy models. It was assumed that the universe is filled with a barotropic perfect fluid with equation of state given by

$$p_\gamma = (\gamma - 1)\rho_\gamma, \quad (3.2)$$

where γ is a constant and $0 \leq \gamma \leq 2$.

Its value is $4/3$ when there is radiation, and is 1 for dust or dark matter. In general, the potential V is assumed to be of the exponential form, $V = V_0 \exp(-\lambda\kappa\varphi)$ in which φ is a scalar field.

3.2 Constructing a Cosmological Dynamical System

In order to construct a dynamical system in a cosmological context, a spatially flat FLRW universe with the following evolution and conservation equations are considered:

$$H^2 = \frac{\kappa^2}{3} \left(\rho_\gamma + \frac{1}{2}\dot{\varphi}^2 + V \right), \quad (3.3)$$

$$\dot{\rho}_\gamma = -3H(\rho_\gamma + P_\gamma), \quad (3.4)$$

$$\ddot{\varphi} = -3H\dot{\varphi} - \frac{dV}{d\varphi}. \quad (3.5)$$

It follows that

$$\dot{H} = -\frac{\kappa^2}{2}(\rho_\gamma + P_\gamma + \dot{\varphi}^2). \quad (3.6)$$

Furthermore, dividing equation (3.3) with H^2 results in

$$1 = \frac{\kappa^2 \rho_\gamma}{3H^2} + \frac{\kappa^2 \dot{\varphi}^2}{6H^2} + \frac{\kappa^2 V}{3H^2}, \quad (3.7)$$

allowing the dimensionless variables x and y to be defined [14, 79] such that

$$x^2 = \frac{\kappa^2 \dot{\varphi}^2}{3H^2}, \quad (3.8)$$

$$y^2 = \frac{\kappa^2 V}{3H^2}, \quad (3.9)$$

leading to the following expression

$$1 - x^2 - y^2 = \frac{\kappa^2 \rho_\gamma}{3H^2} \geq 0, \quad (3.10)$$

implying a unit circle for phase space and boundedness $0 \leq x^2 + y^2 \leq 1$.

Furthermore, from equation (3.3),

$$\Omega_\varphi \equiv \frac{\kappa^2 \rho_\varphi}{3H^2} = x^2 + y^2. \quad (3.11)$$

The effective equation of state for the scalar field is given by

$$\gamma_\varphi \equiv \frac{\rho_\varphi + p_\varphi}{\rho_\varphi} = \frac{\dot{\varphi}^2}{V + \dot{\varphi}^2/2} = \frac{2x^2}{x^2 + y^2}. \quad (3.12)$$

Now, we are ready to derive a 2D system of autonomous ODEs, x' and y' where the prime denotes the differentiation with respect to $N = \ln a$ such that

$$dN = \frac{\dot{a}}{a} dt = H dt, \quad (3.13)$$

By differentiating x with respect to t gives

$$\begin{aligned} \dot{x} &= \frac{\kappa}{\sqrt{6}} \frac{\ddot{\varphi}H - \dot{\varphi}\dot{H}}{H^2} \\ &= \frac{\kappa}{H\sqrt{6}} \left(\ddot{\varphi} - \frac{\dot{\varphi}}{H} \dot{H} \right). \end{aligned} \quad (3.14)$$

Substituting for $\ddot{\varphi}$ and \dot{H} using evolution equations and then using (3.8)

and (3.9) to substitute for $\dot{\varphi}$ and V respectively in terms of x and y , it gives

$$\dot{x} = H \left[-3x + \sqrt{\frac{3}{2}}\lambda y^2 + \frac{3}{2}x ((1 - x^2 - y^2)\gamma + 2x^2) \right]. \quad (3.15)$$

From (3.13),

$$x' = \frac{\dot{x}}{H}. \quad (3.16)$$

Thus, dividing (3.15) with H gives

$$x' = -3x + \sqrt{\frac{3}{2}}\lambda y^2 + \frac{3}{2}x (\gamma(1 - x^2 - y^2) + 2x^2). \quad (3.17)$$

Following similar steps, the equation for y' is obtained as

$$y' = -\lambda\sqrt{\frac{3}{2}}xy + \frac{3}{2}y (2x^2 + \gamma(1 - x^2 - y^2)). \quad (3.18)$$

Thus the system of autonomous equations governing this cosmological dynamical system is

$$\begin{aligned} x' &= -3x + \sqrt{\frac{3}{2}}\lambda y^2 + \frac{3}{2}x (\gamma(1 - x^2 - y^2) + 2x^2), \\ y' &= -\lambda\sqrt{\frac{3}{2}}xy + \frac{3}{2}y (2x^2 + \gamma(1 - x^2 - y^2)). \end{aligned} \quad (3.19)$$

The system is invariant under $y \rightarrow -y$ and time reversal $t \rightarrow -t$, with $y < 0$ or the lower disc of the phase space corresponding to the contracting universe. Thus only the semi-circle is needed to contain the phase-space. The values of λ and γ affect the existence and stability of the critical points and this is summarised in Tables 2 and 3, attributed to [79]. By computing the critical points and the eigenvalues of the system linearised about these points, and by investigating the phase-space of the above system is expected reveal cosmological information of the system in this context. Such information could include whether the model under investigation can admit the evolution of the universe in a way it should be, what the universe will be dominated by etc. Since this model is non-interacting, the dynamical equations

Point	x	y	Existence
A	0	0	$\forall \lambda$ and γ
B	1	0	$\forall \lambda$ and γ
C	-1	0	$\forall \lambda$ and γ
D	$\lambda/\sqrt{6}$	$[1 - \lambda^2/6]^{1/2}$	$\lambda^2 < 6$
E	$(3/2)^{1/2}\gamma/\lambda$	$[3(2 - \gamma)\gamma/2\lambda^2]^{1/2}$	$\lambda^2 > 3\gamma$

Table 2: Summary of the critical points and their existence in uncoupled model.

Point	Stable?	Ω_φ	γ_φ
A	Saddle point for $0 < \gamma < 2$	0	Undefined
B	Unstable node for $\lambda < \sqrt{6}$ Saddle point for $\lambda > \sqrt{6}$	1	2
C	Unstable node for $\lambda > -\sqrt{6}$ Saddle point for $\lambda < -\sqrt{6}$	1	2
D	Stable node for $\lambda^2 < 3\gamma$ Saddle point for $3\gamma < \lambda^2 < 6$	1	$\lambda^2/3$
E	Stable node for $3\gamma < \lambda^2 < 24\gamma^2/(9\gamma - 2)$ Stable spiral for $\lambda^2 > 24\gamma^2/(9\gamma - 2)$	1	γ

Table 3: Summary of the critical points and their stabilities.

involved are relatively simple compared with their interacting counterparts. Thus, it may be possible to find the Lyapunov function of the critical points of the system prove their stability. Existence of a Lyapunov's function is sufficient, but not necessary, to ensure the stability of a critical point. Thus, to apply this technique in a cosmological context, construction of a Lyapunov's function for two of the critical points, D and E, which are, by linear theory, stable nodes for $\lambda^2 < 3\gamma$ and $3\gamma < \lambda^2 < 24\gamma^2/(9\gamma - 2)$ respectively, was considered.

The candidate Lyapunov's functions for these two points are hereby proposed to be

$$V(x, y) = \frac{1}{2} \left(x - \frac{\lambda}{\sqrt{6}} \right)^2 + \frac{1}{2} \left(y - \sqrt{1 - \frac{\lambda}{\sqrt{6}}} \right)^2, \quad (3.20)$$

and

$$V(x, y) = \frac{1}{2} \left(x - \sqrt{\frac{3\gamma}{2\lambda}} \right)^2 + \frac{1}{2} \left(y - \sqrt{\left(3(2-\gamma)\frac{\gamma}{2\lambda^2}\right)} \right)^2, \quad (3.21)$$

respectively and indeed both functions turn out that they are indeed the Lyapunov functions for their respective critical points since they both satisfy

$$V(x_0, y_0) = 0, \quad (3.22)$$

$$V(x, y) > 0 \quad \text{in the neighbourhood of } x_0 \text{ and } y_0, \quad (3.23)$$

$$\dot{V}(x, y) < 0. \quad (3.24)$$

The above condition is affected by the values of the λ and γ chosen, but according to Theorem 2.1 the existence of this function proves the stability of the above two points and it may serve as an alternative to linear stability theory which could be applied in case results obtained via linear theory are inconclusive. It is also possible that a Lyapunov's function of another form may be constructed. This method was extended to interacting dark energy models that were investigated in the chapters that follow but a suitable Lyapunov's function was not discovered. Thus the method has limitations.

A detailed and comprehensive phase-space analysis of this non-interacting model can be found in [79]. This model has interesting features as well as some problems which motivates the idea to be extended, leading towards studying interacting models. In particular, it is possible for the last critical point in the Table 3 to be a scaling solution which might alleviate the fine tuning problem, subject to parameter constraints. However, it does not explain the cosmological constant problem, which needs to be constrained by observations [80]. The shortcoming like this in uncoupled models gives

motivation to study various coupled models.

3.3 Incorporating Interacting Dark Energy into the Dynamical System

Should there be an interaction, represented by Q , energy densities of dark energy and dark matter are governed by conservation equations (1.41) and (1.42). Instead of equation (3.5), the system would be described by a modified Klein-Gordon equation given by equation (1.47). The existence of the interaction term Q may complicate the dynamical equations, depending on the model chosen, and therefore the behaviour of the entire system. In some models, it may not be possible to contain the system in 2D, which would subsequently require a third variable to be defined so as to achieve a 3D system. When considering coupling models, it is natural to consider dark sector coupling in which the universe is one that is dominated by dark energy and dark matter since they are dominant sources in its evolution. The models given by

$$Q_I = \sqrt{\frac{2}{3}}\kappa\beta\rho_c\dot{\varphi}, \quad (3.25)$$

$$Q_{II} = \alpha H\rho_c, \quad (3.26)$$

where α and β are dimensionless constants whose sign represents and determines the direction of energy transfer such that

$$\alpha, \beta \begin{cases} > 0 & \text{energy transfer is dark matter} \rightarrow \text{dark energy;} \\ < 0 & \text{energy transfer is dark energy} \rightarrow \text{dark matter;} \end{cases} \quad (3.27)$$

were considered by Böhmer *et al* [56] taking a dynamical systems approach. Model Q_I was previously studied in [47, 48, 63].

For both models, it was possible to construct a dynamical system whose phase space is contained in two dimensions. It was concluded that the models do not lead to evolution of the system with dark energy dominant and

accelerating universe. A third model [62] given by

$$Q_{III} = \Gamma \rho_c, \quad (3.28)$$

where Γ is, again, a constant that determines the direction of energy transfer demands the introduction of a third variable in order to maintain the compactness of the phase space. This arises from the fact that H could not otherwise be eliminated from the energy conservation equations. Therefore, in [56], a third variable z was defined such that

$$z = \frac{H}{H + H_0}, \quad (3.29)$$

This variable z is chosen to ensure that a compact phase-space is achieved since

$$z = \begin{cases} 0 & \text{if } H = 0 \\ \frac{1}{2} & \text{if } H = H_0 \\ 1 & \text{if } H \rightarrow \infty. \end{cases} \quad (3.30)$$

Therefore, z is bounded by $0 \leq z \leq 1$, resulting in a compactified phase space corresponding to a half-cylinder of unit height and radius. However, inclusion of a third dimension in the phase-space may open up the opportunity for the system to become more mathematically complicated. For this model, the resulting system of autonomous equations read [56]

$$x' = -3x + \lambda \frac{\sqrt{6}}{2} y^2 + \frac{3}{2} x(1 + x^2 - y^2) - \gamma \frac{(1 - x^2 - y^2)z}{2x(z - 1)}, \quad (3.31)$$

$$y' = -\lambda \frac{\sqrt{6}}{2} xy + \frac{3}{2} y(1 + x^2 - y^2), \quad (3.32)$$

$$z' = \frac{3}{2} z(1 - z)(1 + x^2 - y^2). \quad (3.33)$$

Detailed phase-space analysis is in [56]. This model III in particular is claimed to have better physical motivation since the energy transfer rate Γ is independent of the universal expansion rate and determined only by local properties of the dark sector interactions. In fact, it may be reasonable to expect that energy transfer rate and expansion rate of the universe

are unrelated since there is no fundamental theory so far that establishes a relationship between the two. These models investigated in [56] show that it is not always possible to construct a simple dynamical system for all models and that systems may become even more complicated for more realistic models. These models are the basis of motivation for the models investigated in the next chapter.

4 Models with Quadratic Couplings

4.1 Introduction

Quintessence is described by a light scalar field and is said to be important in linking a bridge between string theory [81], a hopeful fundamental theory of nature, and the observable structure of the universe, since light scalar fields are involved in fundamental physics beyond the standard model of particle physics. Unlike the cosmological constant Λ , quintessence is a dynamical field. Furthermore its pressure can become negative. This is required to defy the gravitational attraction and therefore to drive the universe into accelerated expansion. The main motivation behind most of the literature on quintessence as well as this thesis is that it may solve the cosmological coincidence problem. Moreover, so-called tracker field models of quintessence have attractor solutions (see e.g. [30, 82, 83] and references therein) without the need for initial conditions to be fine-tuned, and therefore they are interesting models of dark energy.

The action of quintessence described by an ordinary scalar field φ minimally coupled to gravity is given by [14]

$$S = \int d^4x \sqrt{-g} \left(-\frac{1}{2} (\nabla\varphi)^2 - V(\varphi) \right), \quad (4.1)$$

where $(\nabla\varphi)^2 = \partial^\mu\varphi\partial_\mu\varphi = g^{\mu\nu}\partial_\mu\varphi\partial_\nu\varphi$. It follows that the Lagrangian is therefore given by

$$L = -\frac{1}{2}(\nabla\varphi)^2 - V(\varphi), \quad (4.2)$$

and the equation of motion, known as Klein-Gordon equation, is

$$\ddot{\varphi} + 3H\dot{\varphi} + \frac{dV}{d\varphi} = 0. \quad (4.3)$$

In a FLRW Universe, the components of energy-momentum tensor $T_{\mu\nu}$ of the quintessence field are

$$T_{\mu\nu} = \partial_\mu\varphi\partial_\nu\varphi - g_{\mu\nu} \left[-\frac{1}{2}g^{\alpha\beta}\partial_\alpha\varphi\partial_\beta\varphi + V(\varphi) \right], \quad (4.4)$$

which leads to an expression for energy density and pressure

$$\rho = -T_0^0 = \frac{1}{2}\dot{\varphi}^2 + V(\varphi), \quad (4.5)$$

$$p = T_i^i = \frac{1}{2}\dot{\varphi}^2 - V(\varphi). \quad (4.6)$$

The other evolution equations (3.3) and (3.6) then respectively become

$$H^2 = \frac{8\pi G}{3} \left(\frac{1}{2}\dot{\varphi}^2 + V(\varphi) + \rho_M \right), \quad (4.7)$$

$$\frac{\ddot{a}}{a} = -\frac{8\pi G}{3} \left(\frac{1}{2}\dot{\varphi}^2 - V(\varphi) + \rho_M \right). \quad (4.8)$$

The energy densities of dark energy and (dark) matter respectively satisfy the conservation equations given by

$$\dot{\rho}_\varphi + 3H(1 + w_\varphi)\rho_\varphi = -Q, \quad (4.9)$$

$$\dot{\rho}_M + 3H(1 + w_M)\rho_M = Q, \quad (4.10)$$

where Q is a general coupling term (which is zero when there is no interaction) and the equation of state parameter w of the field φ is expressed as

$$w_\varphi = \frac{p}{\rho} = \frac{\dot{\varphi}^2 - 2V(\varphi)}{\dot{\varphi}^2 + 2V(\varphi)}. \quad (4.11)$$

In order for the universe to undergo accelerated expansion with given potential, the potential must satisfy

$$\dot{\varphi}^2 < V(\varphi), \quad (4.12)$$

which demands a rather flat potential. If we think about this mechanically, the particle rolls down its potential, thereby gaining kinetic energy and losing potential energy. Equation (4.12) poses a stringent condition on the form of the potential. If the potential is not flat enough then it may not give rise to accelerated expansion of the universe. The kinetic energy of the quintessence

is given by

$$-\frac{1}{2}\nabla_{\mu}\varphi\nabla^{\mu}\varphi = \frac{\dot{\varphi}^2}{2}. \quad (4.13)$$

It is possible that kinetic energy term can drive the universe into acceleration. If this is the case, the field responsible for this is called K-essence [34] whose dynamics are more complicated than that described by equation (4.13) and the study of this is beyond the scope of this thesis.

In this chapter, investigation on new form of DE-DM coupling that is quadratic in their energy densities and their background dynamics is presented [84]. The dark energy in this case is assumed to be of the form of a quintessence field with exponential potential. These models here build on the linear models previously introduced in [56, 62], which was motivated by simple models of inflaton decay during reheating and of curvaton decay to radiation. Furthermore, superposition of these models have also been investigated. Many of the previously studied models were constructed with mathematical simplicity in mind and the main aim was to contain the phase space 2-dimensional. For models of the form $Q \propto \rho_c$, one cannot eliminate the Hubble constant from the equations and the introduction of a third variable becomes necessary. In order to construct a dynamical system, dimensionless variables have been defined as in [79] given by equations (3.8) and (3.9). Introduction of these two variables are motivated via the Friedmann constraint. As before, dividing the constraint equation with H^2 after including the matter in the equation, one obtains,

$$1 = \frac{\kappa^2\rho_{\gamma}}{3H^2} + \frac{\kappa^2\dot{\varphi}^2}{6H^2} + \frac{\kappa^2V}{3H^2}, \quad (4.14)$$

and hence

$$1 = \frac{\kappa^2\rho_{\gamma}}{3H^2} + x^2 + y^2. \quad (4.15)$$

Thus, from the constraint equation

$$\Omega_{\varphi} = \frac{\kappa^2\rho_{\gamma}}{3H^2} = x^2 + y^2, \quad (4.16)$$

resulting in a bounded compact space satisfying

$$0 \leq \Omega_\varphi = x^2 + y^2 \leq 1. \quad (4.17)$$

Unlike some of the mathematically simple previous models, all three new models investigated here demand introduction of a third dimension z previously discussed and is defined by [56]

$$z = \frac{H}{H + H_0}.$$

The Hubble evolution equation can be re-written as

$$\frac{\dot{H}}{H^2} = -\frac{3}{2}(1 + x^2 - y^2), \quad (4.18)$$

while the equation of state parameter is

$$w_\varphi = \frac{x^2 - y^2}{x^2 + y^2}, \quad (4.19)$$

and

$$w_{\text{tot}} = x^2 - y^2. \quad (4.20)$$

To further understand the behavior of the system of each model, their relative coupling strengths, denoted by f , have been introduced. This is given by

$$f := \frac{|Q|}{H\rho_c}. \quad (4.21)$$

where the subscript c refers to the cold dark matter.

4.2 Model \mathcal{A} : $Q = \frac{\alpha}{H_0} \rho_\varphi^2$

For this model, the system of autonomous differential equations is

$$x' = -3x + \lambda \frac{\sqrt{6}}{2} y^2 + \frac{3}{2} x(1 + x^2 - y^2) + \alpha \frac{3(1-z)(x^2 + y^2)^2}{2xz}, \quad (4.22)$$

$$y' = -\lambda \frac{\sqrt{6}}{2} xy + \frac{3}{2} y(1 + x^2 - y^2), \quad (4.23)$$

$$z' = \frac{3}{2} z(1-z)(1 + x^2 - y^2). \quad (4.24)$$

The critical points are defined by $x' = 0$, $y' = 0$ and $z' = 0$. In computing the eigenvalues, firstly note that when $z' = 0$ then $z = 0$ or $z = 1$. If the former is the case, then x and y must also be zero as the third term in equation (4.22) is not well-defined. When $z = 1$, in order for equation (4.23) to vanish, $1 + x^2 - y^2 = 0$ must hold, so that $y^2 = 1 + x^2$. In that case, there are five possible solutions for x . Hence there are six critical points in total as summarised in Table 4. Critical points for Model \mathcal{B} and Model \mathcal{C} were computed similarly.

The eigenvalues of the stability matrix are given in Table 4. The characteristics of the critical points and their corresponding effective equation of state for the late-time attractor are summarised in Table 5.

Point	x_*	y_*	z_*	Eigenvalues
A	0	0	0	$-\frac{3}{2}, \frac{3}{2}, \frac{3}{2}$
D	0	0	1	$-\frac{3}{2}, -\frac{3}{2}, \frac{3}{2}$
E_\pm	± 1	0	1	$-3, 3, 3 \mp \sqrt{\frac{3}{2}}\lambda$
F	$\sqrt{\frac{3}{2}\lambda}$	$\sqrt{\frac{3}{2}\lambda}$	1	$-\frac{3}{2}, -\frac{3}{4\lambda}(\lambda \pm \sqrt{24 - 7\lambda^2})$
G	$\frac{\lambda}{\sqrt{6}}$	$\sqrt{1 - \frac{\lambda^2}{6}}$	1	$-\frac{\lambda^2}{2}, -3 + \frac{\lambda^2}{2}, -3 + \lambda^2$

Table 4: Critical points and associated eigenvalues for coupling model \mathcal{A} .

Point	Stable?	Ω_φ	w_T	Acceleration?	Existence
A	Saddle node	0	0	No	$\forall \lambda, \alpha$
D	Saddle node	0	0	No	$\forall \lambda, \alpha$
E_\pm	Saddle node	1	1	No	$\forall \lambda, \alpha$
F	Stable focus for $\lambda^2 > \frac{24}{7}$ Stable node for $3 < \lambda^2 < \frac{24}{7}$	$\frac{3}{\lambda^2}$	0	No	$\lambda^2 \geq 3$
G	Saddle node for $\lambda^2 > 3$ Stable node for $\lambda^2 < 3$	1	$\frac{\lambda^2}{3} - 1$	$\lambda^2 < 2$	$\lambda^2 < 6$

Table 5: The properties of the critical points for model \mathcal{A} .

The phase-space trajectories of Model \mathcal{A} are shown in Figures 4 and 5. For this system, by appropriate choice of λ and α parameter values, evolution of the universe consistent with observations can be achieved. Saddle point A corresponds to the standard matter-dominated universe with $a(t) \propto t^{2/3}$ and the fact that it is unstable means that there exists some trajectories escaping out of it, ending at an attractor, which is the case for certain values of the parameters.

For instance, for a potential that is flat enough (i.e. $\lambda^2 < 2$) trajectories will escape to point G , an attractor, which is completely dark energy dominated. On the other hand, if the potential is not flat enough, then the trajectories will escape to point F which is a scaling solution in which dark energy dominates only a certain fraction.

With $H^2 = \kappa^2 \rho_c / 3$ for matter-dominated universe and from (4.21), the relative coupling strength is computed as

$$f \sim \rho_\varphi^2 / \rho_c^{3/2}. \quad (4.25)$$

which is decreasing into the past. Thus, it seems to imply that the coupling may be weaker in the past, making it possible to have an almost standard matter dominated era.

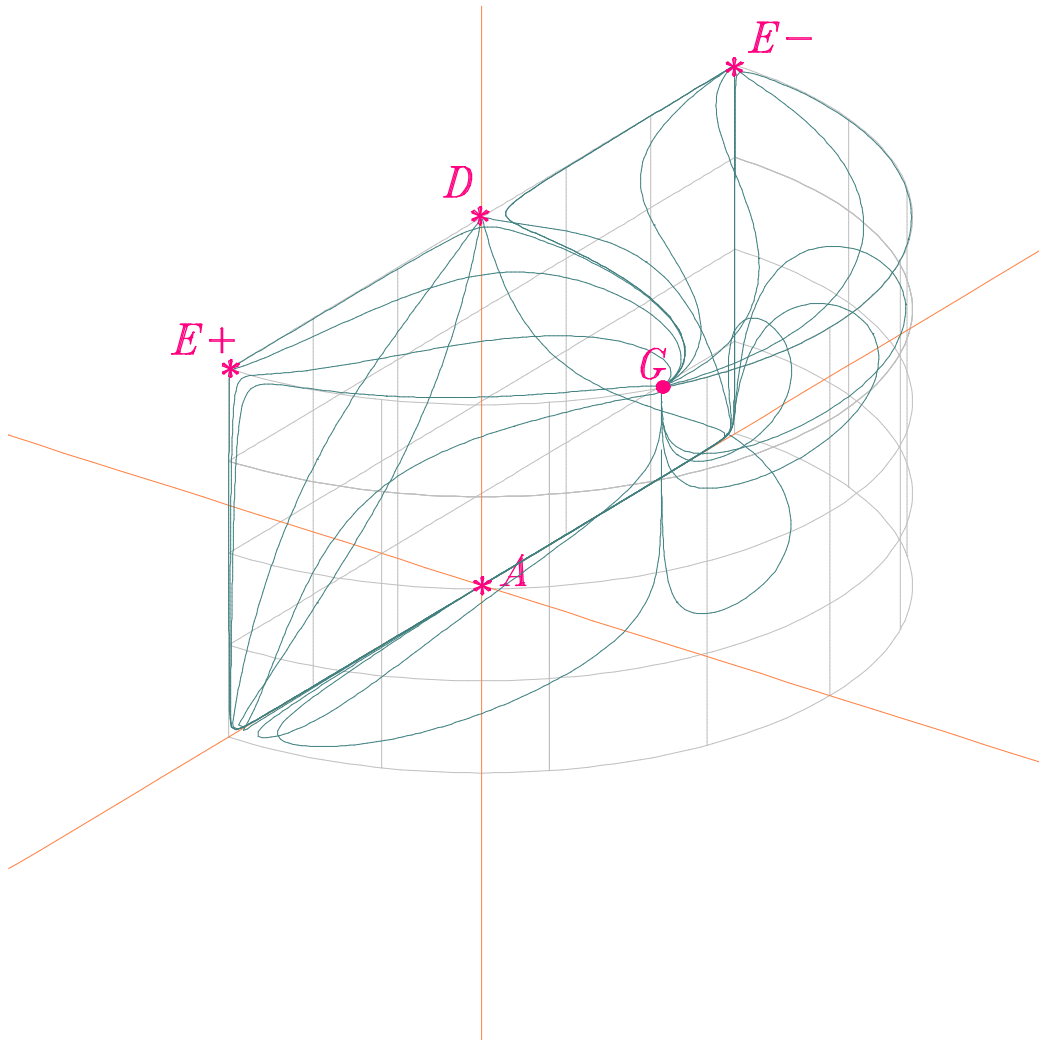

Figure 4: Phase-space trajectories for model \mathcal{A} showing the stable node G , with $\lambda = 1.2$ and $\alpha = 10^{-3}$.

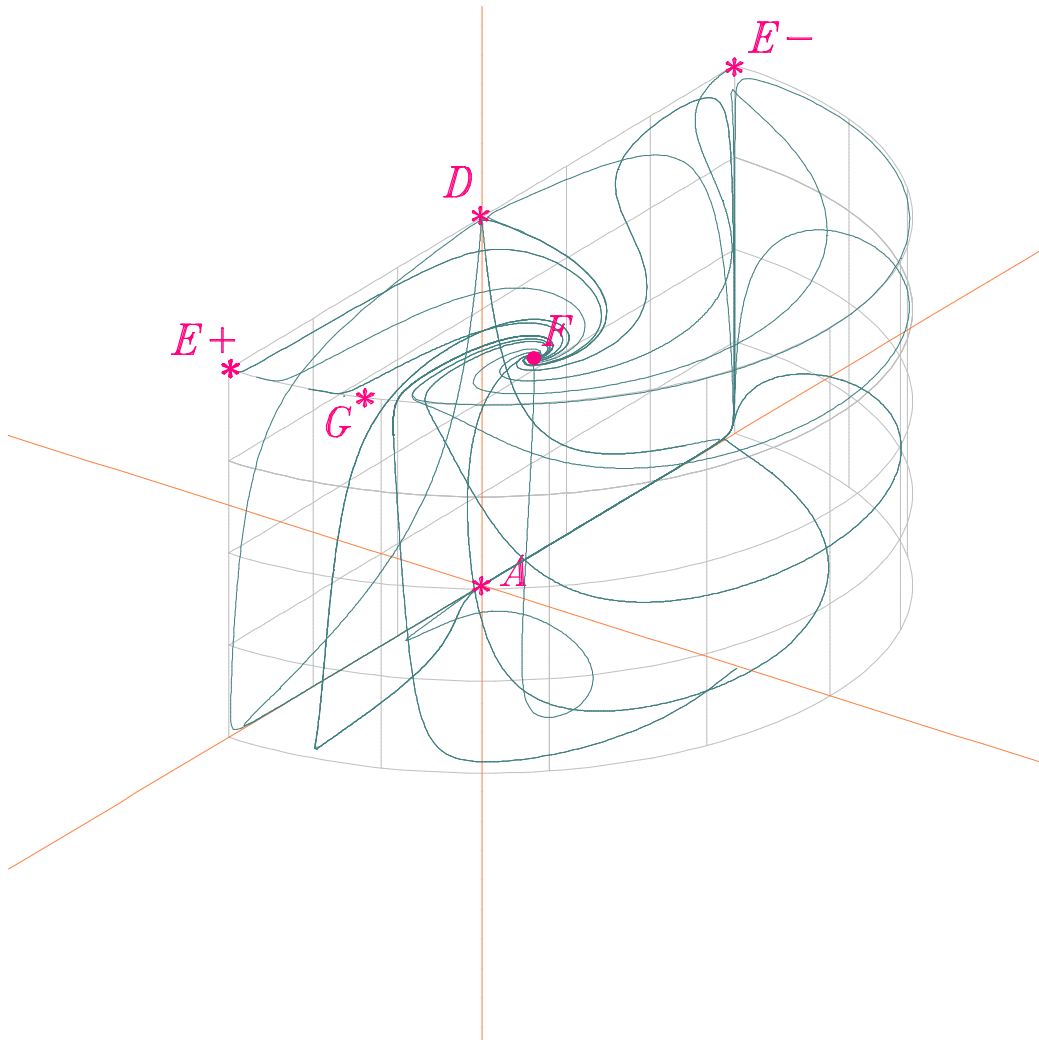

Figure 5: Phase-space trajectories for model \mathcal{A} showing the stable focus F , with $\lambda = 2.3$ and $\alpha = 10^{-3}$.

4.3 Model \mathcal{B} : $Q = \frac{\beta}{H_0} \rho_c^2$

The autonomous system is

$$x' = -3x + \lambda \frac{\sqrt{6}}{2} y^2 + \frac{3}{2} x(1 + x^2 - y^2) + \beta \frac{3(1-z)(1-x^2-y^2)^2}{2xz}, \quad (4.26)$$

$$y' = -\lambda \frac{\sqrt{6}}{2} xy + \frac{3}{2} y(1 + x^2 - y^2), \quad (4.27)$$

$$z' = \frac{3}{2} z(1-z)(1+x^2-y^2). \quad (4.28)$$

The critical points and their stability properties are summarized in Tables 6 and 7 respectively.

Point	x_*	y_*	z_*	Eigenvalues	w_{tot}
B_{\pm}	± 1	0	0	$3, 3, 3 \mp \sqrt{\frac{3}{2}}\lambda$	1
C	$\frac{\lambda}{\sqrt{6}}$	$\sqrt{1 - \frac{\lambda^2}{6}}$	0	$\frac{\lambda^2}{2}, \frac{\lambda^2}{2} - 3, \lambda^2 - 3$	$\frac{\lambda^2}{3} - 1$
D	0	0	1	$-\frac{3}{2}, -\frac{3}{2}, \frac{3}{2}$	0
E_{\pm}	± 1	0	1	$-3, 3, 3 \mp \sqrt{\frac{3}{2}}\lambda$	1
F	$\sqrt{\frac{3}{2}}\frac{1}{\lambda}$	$\sqrt{\frac{3}{2}}\frac{1}{\lambda}$	1	$-\frac{3}{2}, -\frac{3}{4\lambda}(\lambda \pm \sqrt{24 - 7\lambda^2})$	0
G	$\frac{\lambda}{\sqrt{6}}$	$\sqrt{1 - \frac{\lambda^2}{6}}$	1	$-\frac{\lambda^2}{2}, -3 + \frac{\lambda^2}{2}, -3 + \lambda^2$	$\frac{\lambda^2}{3} - 1$

Table 6: Critical points and associated eigenvalues for coupling model \mathcal{B} .

Point	Stable?	Ω_φ	w_T	Acceleration?	Existence
B ₊	Saddle node for $\lambda > \sqrt{6}$ Unstable node for $\lambda < \sqrt{6}$	1	1	No	$\forall \lambda, \beta$
B ₋	Unstable node for $\lambda > -\sqrt{6}$ Saddle node for $\lambda < -\sqrt{6}$	1	1	No	$\forall \lambda, \beta$
C	Saddle node	1	$\frac{\lambda^2}{3} - 1$	$\lambda^2 < 2$	$\lambda^2 < 6$
D	Saddle node	0	0	No	$\forall \lambda, \beta$
E _±	Saddle node	1	1	No	$\forall \lambda, \beta$
F	Stable focus for $\lambda^2 > \frac{24}{7}$ Stable node for $3 < \lambda^2 < \frac{24}{7}$	$\frac{3}{\lambda^2}$	0	No	$\lambda^2 \geq 3$
G	Saddle node for $\lambda^2 > 3$ Stable node for $\lambda^2 < 3$	1	$\frac{\lambda^2}{3} - 1$	$\lambda^2 < 2$	$\lambda^2 < 6$

Table 7: The properties of the critical points for model \mathcal{B} .

The phase-space trajectories of Model \mathcal{B} are shown in Figures 6 and 7. Analysing the critical points reveals that this model does not have a suitable unstable standard matter solution. The ideal situation looking for is such that the model should have an unstable matter-dominated point, from which trajectories would escape to an attractor point dominated by dark energy. This model has been ruled out in subsequent work on superposition of couplings.

From equation (4.21), the relative coupling strength for this model is computed as

$$f \sim H, \quad (4.29)$$

and is increasing to the past. This means that during the early stage of the evolution of the universe, the coupling would get stronger and hence this model is unable to admit an epoch dominated by standard matter.

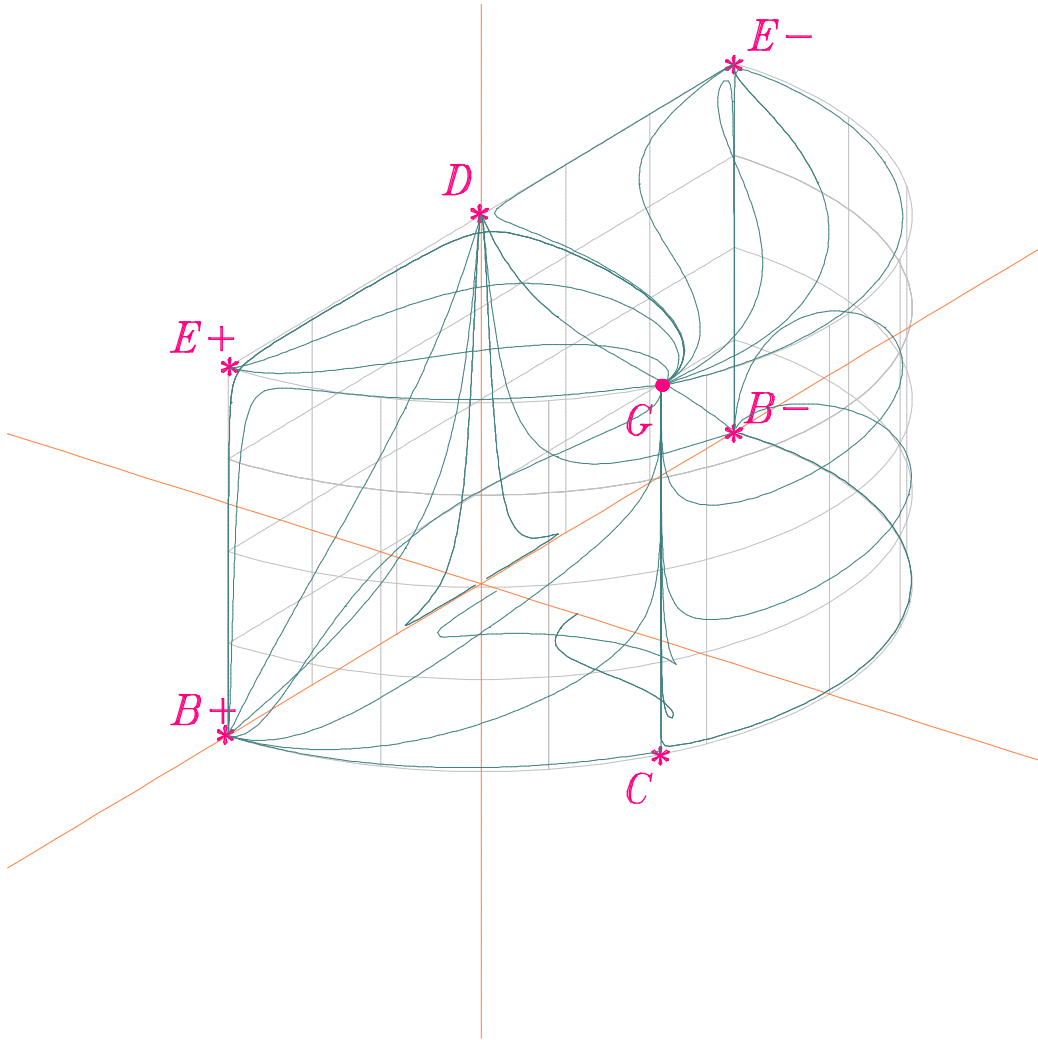

Figure 6: Phase-space trajectories for model \mathcal{B} showing the stable node G , with $\lambda = 1.2$ and $\beta = 10^{-3}$.

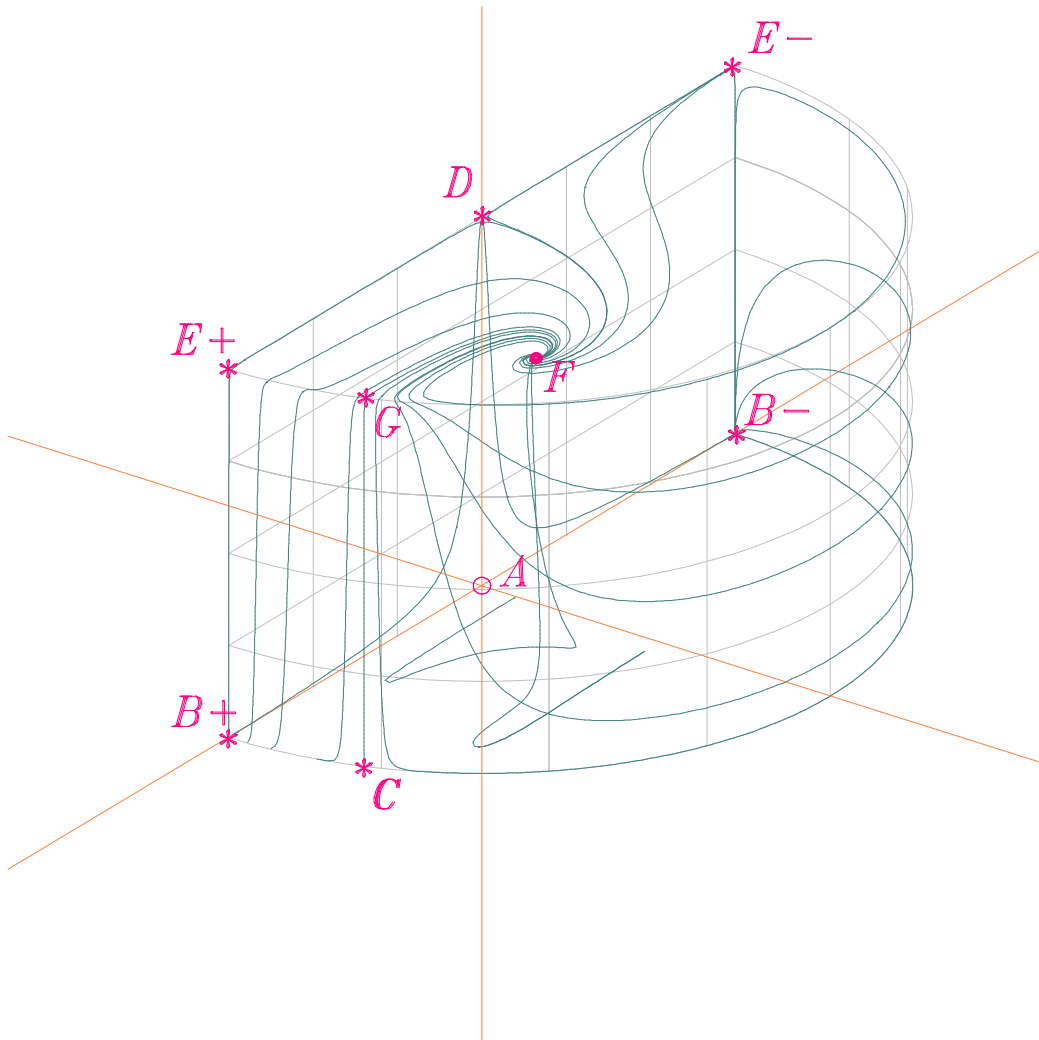

Figure 7: Phase-space trajectories for model \mathcal{B} showing the stable focus F , with $\lambda = 2.3$ and $\beta = 10^{-3}$.

4.4 Model \mathcal{C} : $Q = \frac{\gamma}{H_0} \rho_c \rho_\varphi$

The autonomous system is

$$x' = -3x + \lambda \frac{\sqrt{6}}{2} y^2 + \frac{3}{2} x(1 + x^2 - y^2) + \gamma \frac{3(1-z)(1-x^2-y^2)(x^2+y^2)}{2xz}, \quad (4.30)$$

$$y' = -\lambda \frac{\sqrt{6}}{2} xy + \frac{3}{2} y(1 + x^2 - y^2), \quad (4.31)$$

$$z' = \frac{3}{2} z(1-z)(1+x^2-y^2). \quad (4.32)$$

The critical points and stability of this model are summarised in Tables 8 and 9 respectively. There are infinities in the eigenvalues of the critical points. Whether they are positive or negative are, however, controlled by the sign of γ .

Point	x_*	y_*	z_*	Eigenvalues	w_{tot}
A	0	0	0	$\frac{3}{2}, \frac{3}{2}, \text{sgn}(\gamma)\infty$	0
B_\pm	± 1	0	0	$3, 3 \mp \sqrt{\frac{3}{2}}\lambda, -\text{sgn}(\gamma)\infty$	1
C	$\frac{\lambda}{\sqrt{6}}$	$\sqrt{1 - \frac{\lambda^2}{6}}$	0	$\frac{\lambda^2}{2}, \frac{\lambda^2}{2} - 3, -\text{sgn}(\gamma)\infty$	1
D	0	0	1	$-\frac{3}{2}, -\frac{3}{2}, \frac{3}{2}$	0
E_\pm	± 1	0	1	$-3, 3, 3 \mp \sqrt{\frac{3}{2}}\lambda$	1
F	$\sqrt{\frac{3}{2}}\frac{1}{\lambda}$	$\sqrt{\frac{3}{2}}\frac{1}{\lambda}$	1	$-\frac{3}{2}, -\frac{3}{4\lambda}(\lambda \pm \sqrt{24 - 7\lambda^2})$	0
G	$\frac{\lambda}{\sqrt{6}}$	$\sqrt{1 - \frac{\lambda^2}{6}}$	1	$-\frac{\lambda^2}{2}, -3 + \frac{\lambda^2}{2}, -3 + \lambda^2$	$\frac{\lambda^2}{2} - 1$

Table 8: Critical points and associated eigenvalues for coupling model \mathcal{C} .

Point	Stable?	Ω_φ	w_T	Acceleration?	Existence
A	Unstable node for $\gamma > 0$ Saddle node for $\gamma < 0$	0	0	No	$\forall \lambda, \gamma$
B ₊	Unstable node for $\lambda < \sqrt{6}$ and $\gamma < 0$ Saddle otherwise	1	1	No	$\forall \lambda, \gamma$
B ₋	Unstable node for $\lambda > -\sqrt{6}$ and $\gamma < 0$ Saddle otherwise	1	1	No	$\forall \lambda, \gamma$
C	Saddle node	1	$\frac{\lambda^2}{3} - 1$	$\lambda^2 < 2$	$\lambda^2 < 6$
D	Saddle node	0	0	No	$\forall \lambda, \beta$
E _±	Saddle node	1	1	No	$\forall \lambda, \beta$
F	Stable focus for $\lambda^2 > \frac{24}{7}$ Stable node for $3 < \lambda^2 < \frac{24}{7}$	$\frac{3}{\lambda^2}$	0	No	$\lambda^2 \geq 3$
G	Saddle node for $\lambda^2 > 3$ Stable node for $\lambda^2 < 3$	1	$\frac{\lambda^2}{3} - 1$	$\lambda^2 < 2$	$\lambda^2 < 6$

Table 9: The properties of the critical points for model \mathcal{C} .

The phase-space trajectories of Model \mathcal{C} are shown in figures 8 and 9. In this model, there exist an unstable matter era point, which is point A , when $\gamma > 0$ and this is generic as it occurs in all directions. On the other hand, when $\gamma < 0$, it becomes a saddle point. Furthermore, acceleration can be achieved at two possible attractors completely dominated by dark energy if the potential is flat enough i.e. if the value of λ is small enough. This model, therefore, exhibits some interesting properties. The relative coupling strength of this model is computed as

$$f \sim \rho_\varphi^2 / \rho_c^{1/2}, \quad (4.33)$$

which means it is decreasing into the past. Therefore, it indicates that the strength of the coupling was weaker in the early era of the universe.

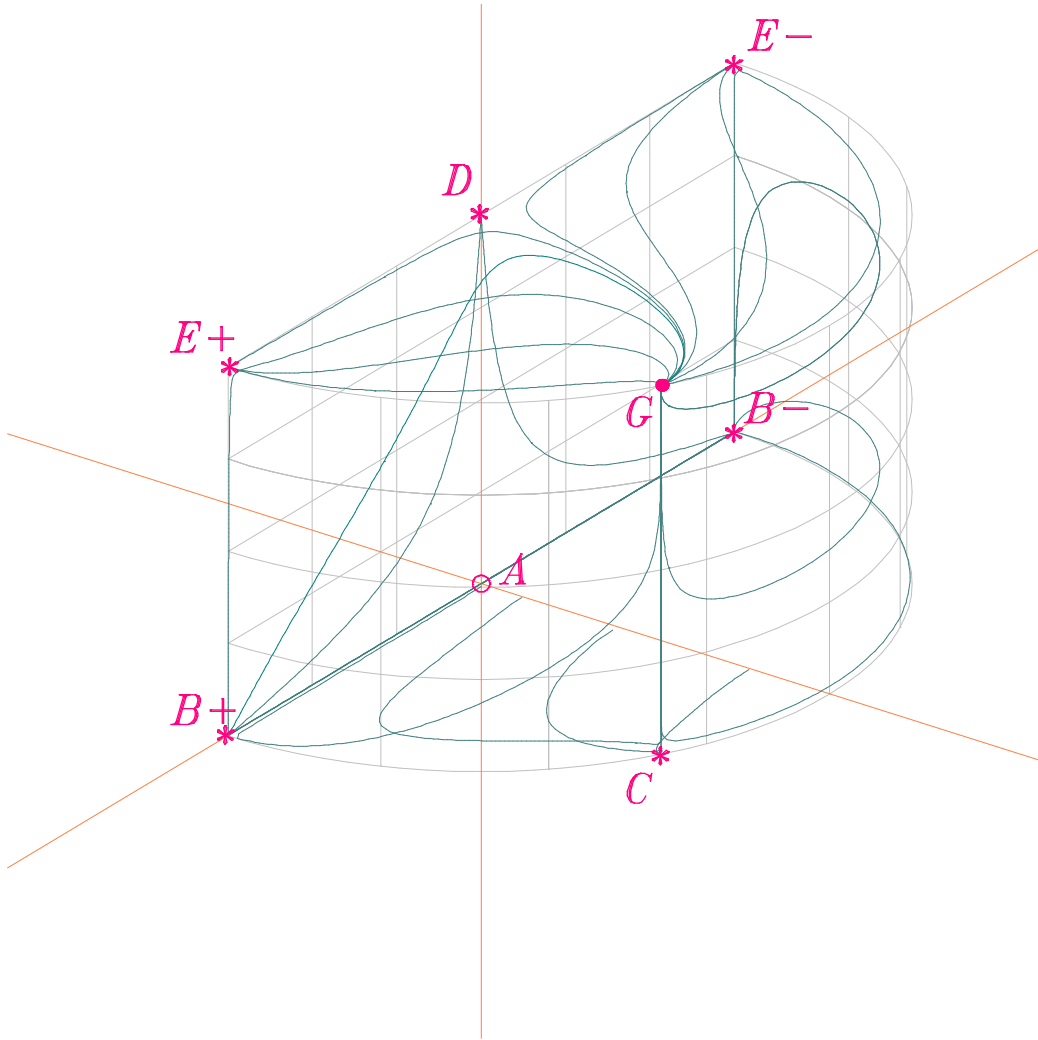

Figure 8: Phase-space trajectories for model \mathcal{C} showing the stable node G , with $\lambda = 1.2$ and $\gamma = 10^{-3}$

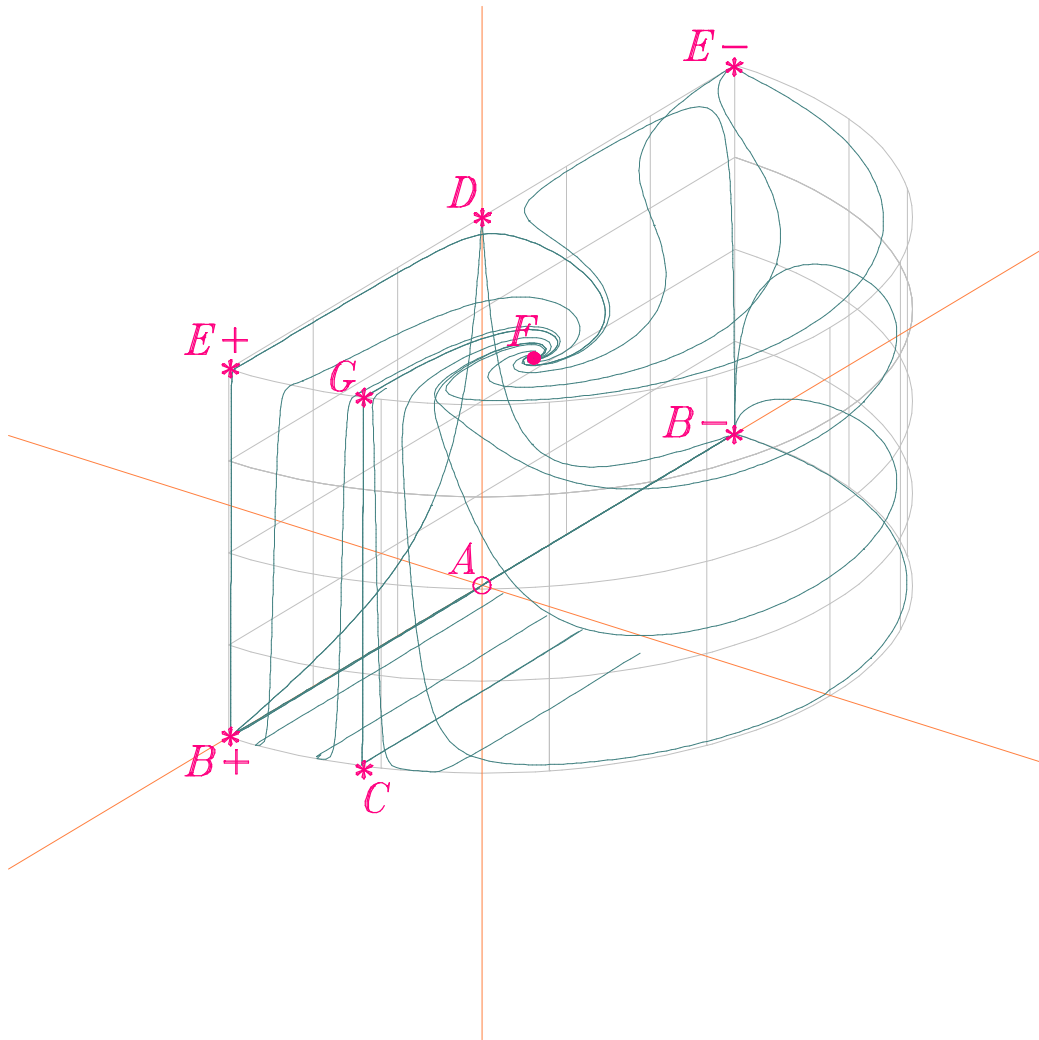

Figure 9: Phase-space trajectories for model \mathcal{C} showing the stable focus F , with $\lambda = 2.3$ and $\gamma = 10^{-3}$

4.5 Superposition of Couplings

When the different coupling models are combined, it was expected that only those critical points that would be present are those of each individual model. Since it was the intention to describe the evolution of the universe that includes a standard matter era and evolves towards a stable accelerating solution, the model \mathcal{B} which appears to not admit suitable standard matter era has been omitted in the superposition of couplings. Only the combination of the models \mathcal{A} and \mathcal{C} were chosen since those are the ones that allow for a standard matter era. The superposition of the couplings is then given by

$$Q = \frac{\alpha}{H_0} \rho_\varphi^2 + \frac{\gamma}{H_0} \rho_c \rho_\varphi. \quad (4.34)$$

It has been noted that the two couplings are decoupled in the sense that there are no cross-coupling terms in the dynamical system.

This superposition results in the following system of autonomous differential equations

$$\begin{aligned} x' &= -3x + \lambda \frac{\sqrt{6}}{2} y^2 + \frac{3}{2} x(1 + x^2 - y^2) \\ &+ \alpha \frac{3(1-z)(x^2 + y^2)^2}{2xz} \\ &+ \gamma \frac{3(1-z)(1-x^2-y^2)(x^2 + y^2)}{2xz}, \end{aligned} \quad (4.35)$$

$$y' = -\lambda \frac{\sqrt{6}}{2} xy + \frac{3}{2} y(1 + x^2 - y^2), \quad (4.36)$$

$$z' = \frac{3}{2} z(1-z)(1 + x^2 - y^2). \quad (4.37)$$

The critical points and their stability are listed in Tables 10 and 11 respectively. The phase-space trajectories of this superposition model are shown in Figures 10 and 11.

Point	x_*	y_*	z_*	Eigenvalues	w_{tot}
A	0	0	0	$\text{sgn}(\gamma)\infty, \frac{3}{2}, \frac{3}{2}$	0
D	0	0	1	$-\frac{3}{2}, -\frac{3}{2}, \frac{3}{2}$	0
E_{\pm}	± 1	0	1	$-3, 3, 3 \mp \sqrt{\frac{3}{2}}\lambda$	1
F	$\frac{1}{\lambda}\sqrt{\frac{3}{2}}$	$\frac{1}{\lambda}\sqrt{\frac{3}{2}}$	1	$-\frac{3}{2}, -\frac{3}{4\lambda}(\lambda \pm \sqrt{24 - 7\lambda^2})$	0
G	$\frac{\lambda}{\sqrt{6}}$	$\sqrt{1 - \frac{\lambda^2}{6}}$	1	$-\frac{\lambda^2}{2}, -3 + \frac{\lambda^2}{2}, \lambda^2 - 3$	$\frac{\lambda^2}{2} - 1$

Table 10: Critical points and associated eigenvalues for the superposition of couplings for model \mathcal{A} and model \mathcal{C} .

Point	Stable?	Ω_{φ}	w_T	Acceleration?	Existence
A	Saddle node for $\gamma < 0$ Stable node for $\gamma > 0$	0	0	No	$\forall \lambda, \alpha, \beta, \gamma$
D	Saddle node	0	0	No	$\forall \lambda, \alpha, \beta, \gamma$
E_{\pm}	Saddle node	1	1	No	$\forall \lambda, \alpha, \beta, \gamma$
F	Stable focus for $\lambda^2 > \frac{24}{7}$ Stable node for $3 < \lambda^2 < \frac{24}{7}$	$\frac{3}{\lambda^2}$	0	No	$\lambda^2 \geq 3$
G	Saddle node for $\lambda^2 > 3$ Stable node for $\lambda^2 < 3$	1	$\frac{\lambda^2}{3} - 1$	$\lambda^2 < 2$	$\lambda^2 < 6$

Table 11: The properties of the critical points for the superposition of couplings.

We see that there are two points, A and D , corresponding to the standard matter era. Point G is the accelerated attractor dominated by dark energy for a flat enough potential in which $\lambda^2 < 2$.

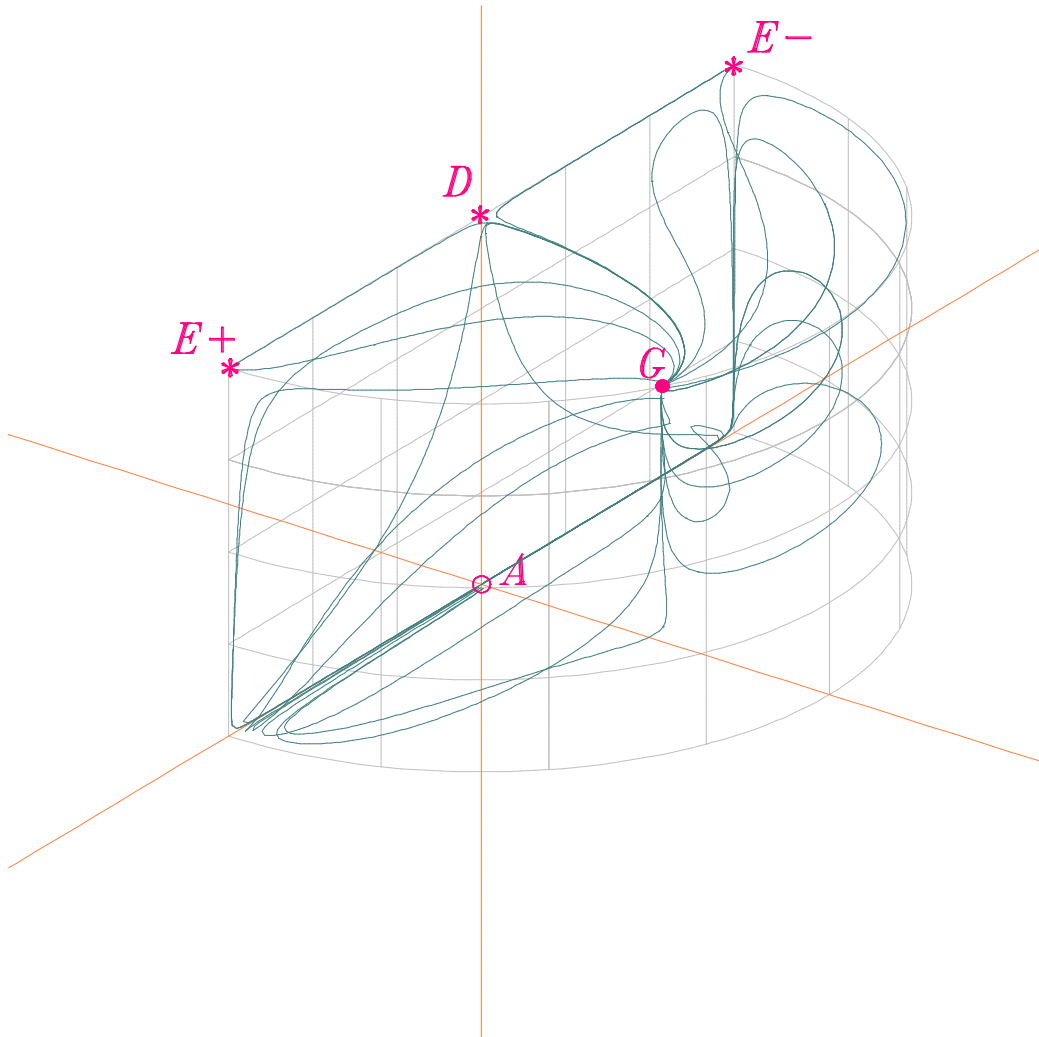

Figure 10: Phase-space trajectories for the superposition of couplings showing the stable node G , with $\lambda = 1.2, \alpha = 2$ and $\gamma = 2 \times 10^{-3}$.

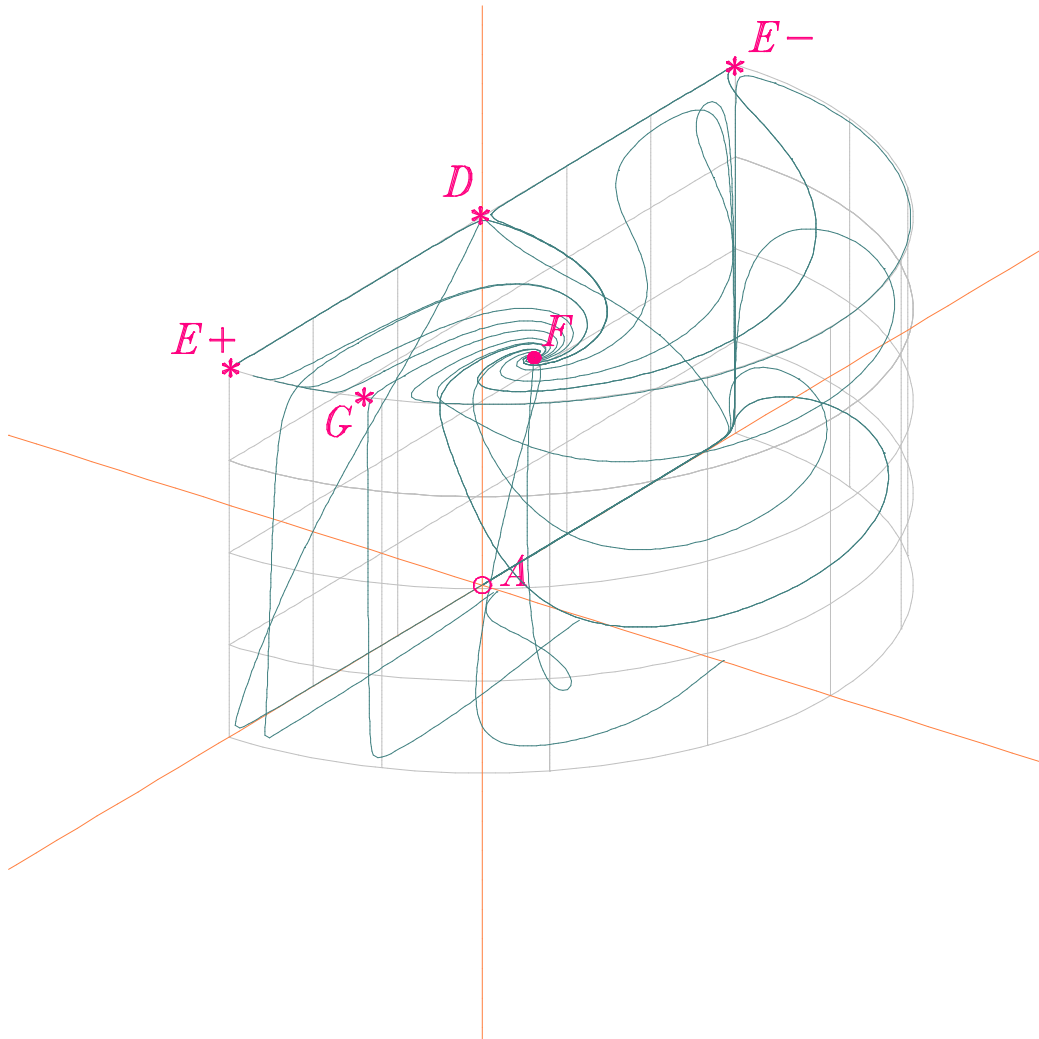

Figure 11: Phase-space trajectories for the superposition of couplings showing the stable focus F , with $\lambda = 2.3, \alpha = 2$ and $\gamma = 2 \times 10^{-3}$.

4.6 Conclusion

In investigating these new models, a comprehensive analysis of the background dynamics for a new class of models with quadratic coupling is performed. The introduction of coupling results in the following extra respective terms in the x' equation of the models,

$$Q = \begin{cases} \alpha \frac{3(1-z)(x^2+y^2)^2}{2xz} & \text{Model } \mathcal{A}, \\ \beta \frac{3(1-z)(1-x^2-y^2)^2}{2xz} & \text{Model } \mathcal{B}, \\ \gamma \frac{3(1-z)(1-x^2-y^2)(x^2+y^2)}{2xz} & \text{Model } \mathcal{C}. \end{cases} \quad (4.38)$$

The rest of the equations in the systems remain the same. Their relative coupling strengths are

$$f \sim \begin{cases} \rho_\varphi^2 / \rho_c^{3/2} & \text{Model } \mathcal{A}, \\ H & \text{Model } \mathcal{B}, \\ \rho_\varphi^2 / \rho_c^{1/2} & \text{Model } \mathcal{C}. \end{cases} \quad (4.39)$$

Higher-order couplings may be treated in similar way. The most general form of such coupling may be expressed as

$$Q = \sum_{m,n} q_{mn} \rho_c^m \rho_\varphi^n, \quad (4.40)$$

where m and n are non-negative integers, and q_{mn} is an arbitrary matrix which is not necessarily a square matrix and hence has no *no priori* symmetry properties but with the condition $q_{00} = 0$. The linear model [56] given by a special case $Q = \Gamma \rho_c$ was the most general linear model given by $Q = -(\Gamma_c \rho_c + \Gamma_\varphi \rho_\varphi)$ [85]. This general linear model and the quadratic models can be brought into the general form 4.40 by writing

$$q_{mn} = \begin{pmatrix} 0 & \Gamma_\varphi \\ \Gamma_c & 0 \end{pmatrix}, \quad (4.41)$$

and

$$q_{mn} = \begin{pmatrix} 0 & 0 & \mathcal{A} \\ 0 & \mathcal{B} & 0 \\ \mathcal{C} & 0 & 0 \end{pmatrix}, \quad (4.42)$$

respectively.

By investigating the phase-space and behaviour of the trajectories, it can be concluded that while model \mathcal{B} leads to a universe without a standard matter era, models \mathcal{A} and \mathcal{C} admit a standard matter era and an evolution that connects this to a late-time attractor. This attractor allows possibility for acceleration to take place provided that the potential chosen is flat enough. Furthermore, models \mathcal{A} and \mathcal{C} are not affected by the direction of the energy transfer. On the other hand, for model \mathcal{C} , for $Q > 0$ the instability of the matter era is more generic; so there is in some sense more room for a transition from the matter era to the accelerated attractor. With all these established, these quadratic models which admit a viable background evolution can be compared to observations in order to constrain the parameters α and γ , which may then require investigation of cosmological perturbations which is beyond the scope of this thesis. We refer the reader to [62, 86] for an example of work done in such direction.

5 A Simple Model of Self-interacting Three-form and the Failure of Linear Stability Theory

In this chapter, motivated by recent studies on three-forms [87, 88], we study an interacting three-form field model. As in previous chapters, a dynamical system was constructed by rewriting the field equations in the form of a system of autonomous differential equations. Having encountered the failure of linear stability theory in investigating the system, this chapter aims to point out the possibility of applying an alternative technique. Explicitly, it demonstrates how centre manifold theory can be applied to study complicated dynamical systems in the context of cosmology [89–91] and therefore one of the aims is to build a bridge between the mathematical area of dynamical systems and cosmology. More specifically, how to compute the centre manifold of a dynamical system of cosmological interest has been demonstrated. The dynamics of the original system is then restricted to that of the corresponding centre manifold.

5.1 Introduction

A simple model of self-interacting three-forms has been considered. The role of three-forms in cosmology is motivated by vector field inflation [92]. Three-forms, a class of p -forms, are said to be able to give rise to viable cosmological scenarios of inflation and dark energy with potentially observable signatures which can be distinguished from standard single scalar field models. Vector field dark energy models have been studied extensively since it has been shown that it may alleviate the cosmological coincidence problem. It was first introduced and studied by Koivisto *et al* [93].

The action of the three-form is given by [87, 88]

$$S_A = - \int d^4x \sqrt{-g} \left(\frac{1}{2\kappa^2} R - \frac{1}{48} F^2 - V(A^2) \right), \quad (5.1)$$

where $F(A)$ is the generalisation of the Faraday form appearing in Maxwell theory. The explicit derivation of the energy-momentum tensor $T_{\mu\nu}$ can be found in [94]. The non-zero components of the most general three-form field compatible with a homogeneous and isotropic geometry is given by [87]

$$A_{ijk} = a^3 \epsilon_{ijk} X(t), \quad (5.2)$$

where $X(t)$ is a scalar function of time and i, j, k are the spatial indices. The equation of motion of the field is given by a modified Klein Gordon equation which reads [87]

$$\ddot{X} = -3H\dot{X} - V_{,X} - 3\dot{H}X, \quad (5.3)$$

in the absence of any coupling, where the subscript “, X ” means derivative with respect to X .

When there is some general coupling Q , then it becomes

$$\ddot{X} = -3H\dot{X} - V_{,X} - 3\dot{H}X - \frac{Q}{\dot{X} + 3HX}. \quad (5.4)$$

The reason for this slightly unusual term of $\frac{Q}{\dot{X} + 3HX}$ comes from the fact that we introduced the coupling at the level of conservation equations in terms of density and pressure. When this is rewritten in terms of the field X , this coupling becomes divided by the kinetic term.

As before, the sign of Q determines the direction of energy transfer. An exponential potential [79] of the form

$$V(X) = V_0 e^{-\lambda X}, \quad (5.5)$$

was chosen and λ is a dimensionless parameter and $V_0 > 0$.

The equations for energy density and pressure are

$$\rho_X = \frac{1}{2}(\dot{X} + 3HX)^2 + V(X), \quad (5.6)$$

$$p_X = -\frac{1}{2}(\dot{X} + 3HX)^2 - V(X) + V_{,X}X, \quad (5.7)$$

respectively, while the other evolution equations are

$$H^2 = \frac{\kappa^2}{3} \left(\frac{1}{2} (\dot{X} + 3HX)^2 + V(X) + \rho_{\text{DM}} \right), \quad (5.8)$$

$$\dot{H} = \frac{\kappa}{2} (V_{,X} X + \rho_{\text{DM}}). \quad (5.9)$$

5.2 Constructing a Dynamical System for the Three-form with Simple Coupling to Dark Matter

Dividing both sides of (5.8) with H^2 gives

$$1 = \frac{\kappa^2}{6H^2} \left(\dot{X} + 3HX \right)^2 + \frac{\kappa^2 V(x)}{3H^2} + \frac{\kappa^2 \rho_c}{3H^2}, \quad (5.10)$$

Without loss of generality, the value of κ can be set to 1. Together with this, some dimensionless compact variables have been introduced and defined as following [95]

$$x := \frac{1}{\sqrt{6}H} (\dot{X} + 3HX), \quad (5.11)$$

$$y := \frac{\sqrt{V}}{\sqrt{3}H}, \quad (5.12)$$

$$z := \frac{2}{\pi} \arctan \left[\frac{3X}{\sqrt{6}} \right], \quad (5.13)$$

$$s := \frac{\rho_{\text{DM}}}{\sqrt{3}H}. \quad (5.14)$$

This is similar to, but deviates from, Koivisto and Nunes [87] who defined the dynamical variables as

$$x := \kappa X, \quad (5.15)$$

$$y := \frac{\kappa}{\sqrt{6}} (X' + 3X), \quad (5.16)$$

$$z := \frac{\kappa\sqrt{V}}{\sqrt{3}H}, \quad (5.17)$$

$$w^2 := \frac{\kappa\sqrt{\rho}}{\sqrt{3}H}, \quad (5.18)$$

$$\lambda(x) := -\frac{1}{\kappa} \frac{V_{,X}}{V}, \quad (5.19)$$

with the Friedmann constraint

$$y^2 + z^2 + w^2 = 1. \quad (5.20)$$

Note that x can range in the whole of \mathbb{R} . The advantage of our choice of variables is that the phase space is then compactified by construction and thus the possible presence of critical points at infinity does not cause any concern. These variables can be motivated by noting that the Friedmann constraint now becomes

$$x^2 + y^2 + s^2 = 1. \quad (5.21)$$

It is also noted here that by construction $-1 \leq z \leq 1$, and moreover $-1 \leq x \leq 1$, $0 \leq y \leq 1$ and $0 \leq s \leq 1$. The resulting phase space is therefore a half cylinder with height 2. The price we have to pay for this is the introduction of the inverse tangent function. While this makes some calculations slightly harder, it seems to significantly improve our understanding of the phase-space.

The equation of state parameter for the three-form field is defined by

$w_X = p_X/\rho_X$ and thus can be written as

$$w_X = -1 + \frac{V_{,X}X}{\rho_X} = -1 - \frac{1}{x^2 + y^2} \sqrt{\frac{2}{3}} y^2 \lambda \tan \left[\frac{\pi z}{2} \right]. \quad (5.22)$$

Similarly, the total equation of state parameter becomes

$$w_{\text{tot}} = -x^2 - \frac{1}{3} y^2 \left(3 + \sqrt{6} \lambda \tan \left[\frac{\pi z}{2} \right] \right). \quad (5.23)$$

Recall that the condition for acceleration is $w_{\text{tot}} < -1/3$. The coupling Q has been chosen to be of the mathematically simple form

$$Q = \alpha \rho_{\text{DM}} H, \quad (5.24)$$

where α is a dimensionless constant. The uncoupled case would correspond to $\alpha = 0$. This results in the following autonomous system of differential equations

$$x' = \frac{3}{2} x (1 - x^2 - y^2) + \sqrt{\frac{3}{2}} y^2 \lambda \left(1 - x \tan \left[\frac{\pi z}{2} \right] \right) - \alpha \frac{(1 - x^2 - y^2)}{2x}, \quad (5.25)$$

$$y' = \frac{3}{2} y (1 - x^2 - y^2) - \sqrt{\frac{3}{2}} y \lambda \left(x + (-1 + y^2) \tan \left[\frac{\pi z}{2} \right] \right), \quad (5.26)$$

$$z' = \frac{6}{\pi} \cos \left[\frac{\pi z}{2} \right]^2 \left(x - \tan \left[\frac{\pi z}{2} \right] \right). \quad (5.27)$$

It has been noted that the system of equations is invariant under the map $y \rightarrow -y$ and thus focusing on the analysis on the $y \geq 0$ case is sufficient. This also comes from the fact that the potential is positive definite. The number of critical points of this dynamical system depends on the coupling parameter α . Starting with $\alpha = 0$, the results of [87] are obtained and are summarised in Table 12.

In the presence of a coupling i.e. $\alpha \neq 0$, the number of critical points changes. Specifically, the point B_0 splits into two different critical points. Furthermore, these two points move within the phase-space as the coupling strength parameter α is varied. The points A_{\pm} remain unchanged, however, their eigenvalues do change. This is summarised in Table 13.

Point	x	y	z	eigenvalues	w_X	w_{tot}
A_+	1	0	$\frac{1}{2}$	$0, -3, -3$	-1	-1
A_-	-1	0	$-\frac{1}{2}$	$0, -3, -3$	-1	-1
B_0	0	0	0	$\frac{3}{2}, \frac{3}{2}, -3$	-1	0

Table 12: Critical points in uncoupled case of three-form cosmology.

Point	x	y	z	eigenvalues	w_X	w_{tot}
A_+	1	0	$\frac{1}{2}$	$0, -3, -3 + \alpha$	-1	-1
A_-	-1	0	$-\frac{1}{2}$	$0, -3, -3 + \alpha$	-1	-1
B_+	$\sqrt{\frac{\alpha}{3}}$	0	$\frac{2}{\pi} \arccos \left[\frac{\sqrt{3}}{\sqrt{\alpha+3}} \right]$	$-3, -\alpha + 3, (-\alpha + 3)/2$	-1	$-\frac{\alpha}{3}$
B_-	$-\sqrt{\frac{\alpha}{3}}$	0	$-\frac{2}{\pi} \arccos \left[\frac{\sqrt{3}}{\sqrt{\alpha+3}} \right]$	$-3, -\alpha + 3, (-\alpha + 3)/2$	-1	$-\frac{\alpha}{3}$

Table 13: Critical points in the coupled case of three-form cosmology.

The birth and movement of the new critical points with respect to the coupling parameter α are also illustrated in the Figures 12, 13 and 14.

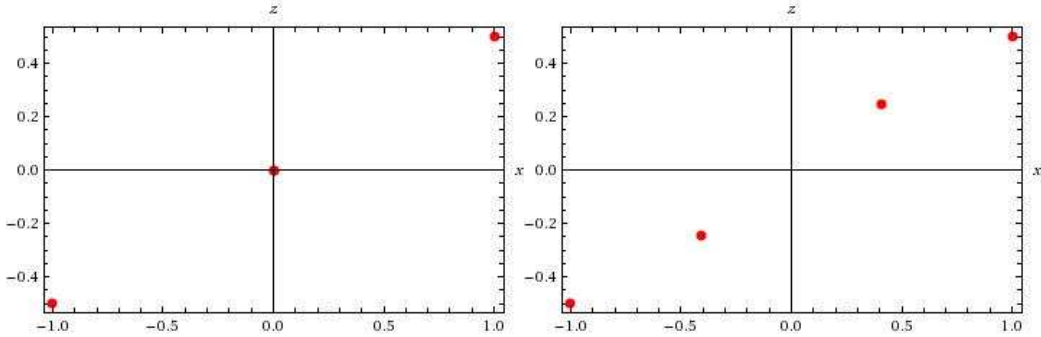

Figure 12: Illustration of the movement of critical points in cases $\alpha = 0$ and a small value of α .

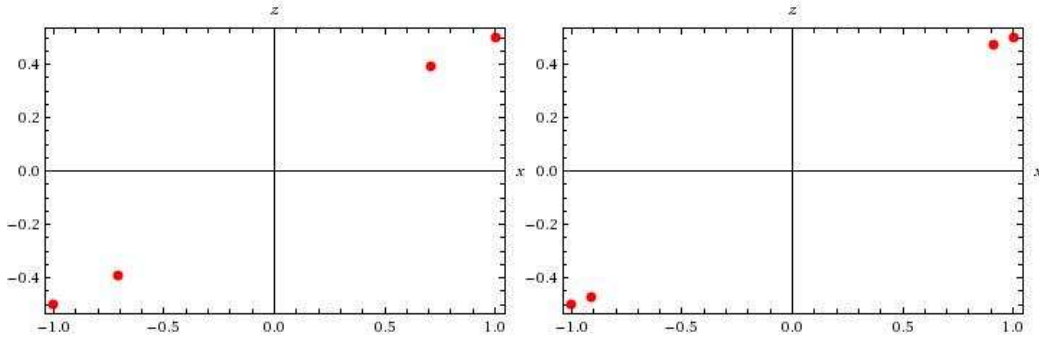

Figure 13: Illustration of the movement of critical points as α value gradually increases.

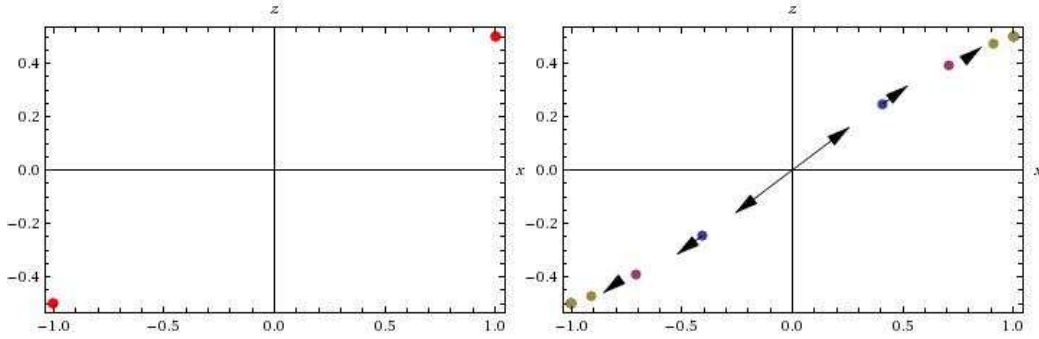

Figure 14: Critical points at $\alpha = 3$ (left) and illustration of the movement of critical points with respect to α (right).

As the coupling strength increases to its maximally allowed value $\alpha \rightarrow 3$, the two points B_{\pm} move towards the points A_{\pm} . We focus our analysis to $0 \leq \alpha \leq 3$. When $\alpha = 3$ these points merge and the system has two critical points, each with two zero eigenvalues. The fact that critical points are created or destroyed, the nature of their stability change with respect to parameters in the coupling corresponds to the mathematical phenomena of bifurcations. This leads to the possibility of applying bifurcation theory to study cosmological systems, a technique that has not been widely employed in this context. As far as this thesis is concerned, we will not apply the theory of bifurcations to study cosmological models.

The phase-space of the system for uncoupled case and coupled case are

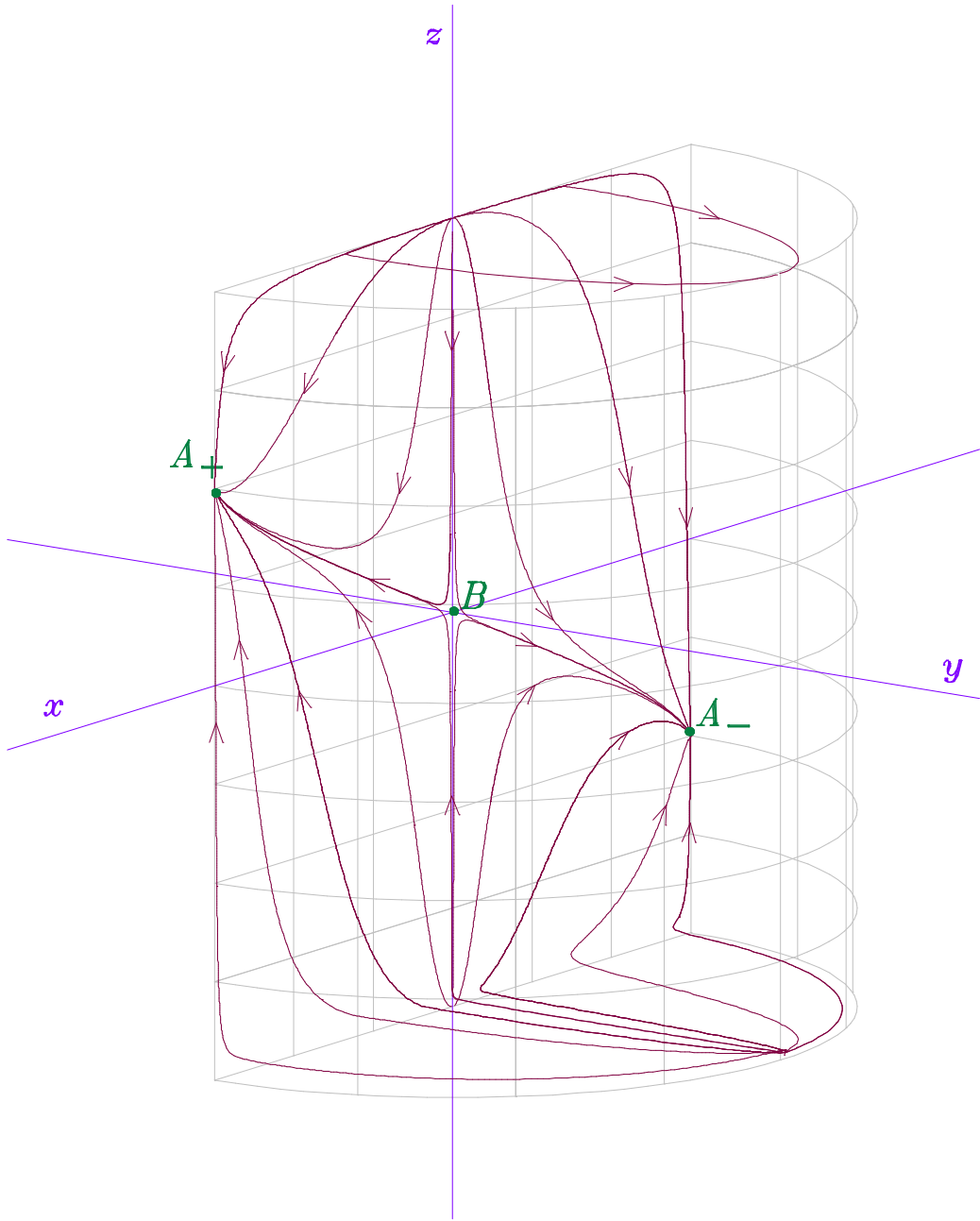

Figure 15: Trajectories in the uncoupled three-form model

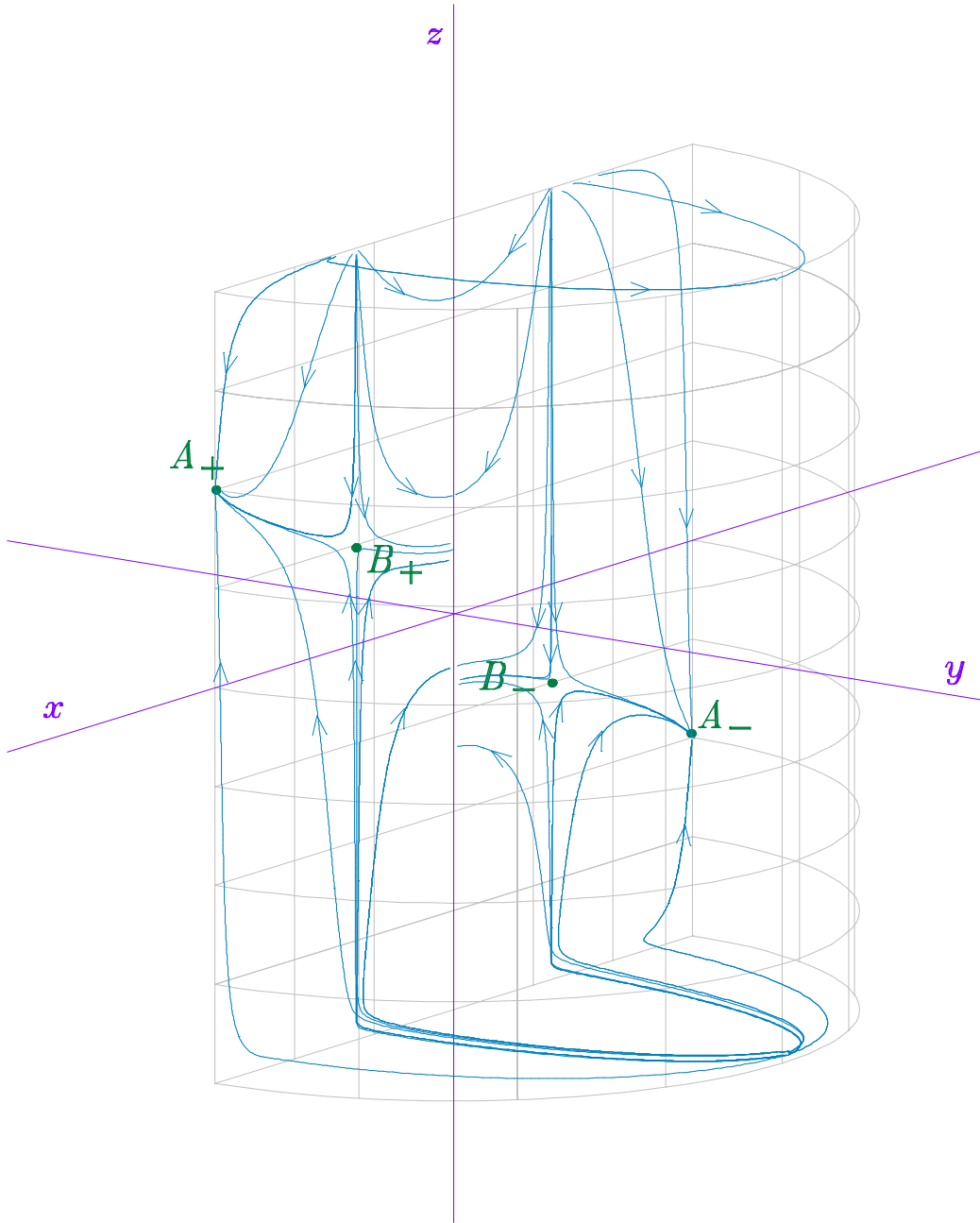

Figure 16: Trajectories in the coupled three-form model

portrayed in Figures 15 and 16.

5.3 Applying the Centre Manifold Theory

With the presence of zero eigenvalues in the critical points A_{\pm} , linear stability theory fails to reveal information regarding these points. Therefore, we apply the centre manifold theory to the system (5.25)–(5.27) for the critical points A_{\pm} . Let us focus on A_+ point. Before proceeding, in order to apply the centre manifold theory, this system needs to be transformed into the form of (2.13). Firstly, for this point, coordinates are rescaled such that

$$X = x - 1, \quad (5.28)$$

$$Y = y, \quad (5.29)$$

$$Z = z - \frac{1}{2}. \quad (5.30)$$

so that this rescaling moves the point $(1, 0, 1/2)$ to the origin $(0, 0, 0)$ of the phase space. Under the coordinate transformation, the stability matrix was computed as

$$\begin{pmatrix} \frac{dX'}{dX} & \frac{dX'}{dY} & \frac{dX'}{dZ} \\ \frac{dY'}{dX} & \frac{dY'}{dY} & \frac{dY'}{dZ} \\ \frac{dZ'}{dX} & \frac{dZ'}{dY} & \frac{dZ'}{dZ} \end{pmatrix}, \quad (5.31)$$

which results in

$$\begin{pmatrix} \alpha - 3 & 0 & 0 \\ 0 & 0 & 0 \\ \frac{3}{\pi} & 0 & -3 \end{pmatrix}, \quad (5.32)$$

The eigenvectors of the matrix (5.32) in the coordinate system (X, Y, Z) are

$$\begin{pmatrix} 0 \\ -3/(\pi\alpha) \\ 3/(\pi\alpha) \end{pmatrix}, \begin{pmatrix} 1 \\ 0 \\ 0 \end{pmatrix}, \begin{pmatrix} 0 \\ 1 \\ 0 \end{pmatrix}. \quad (5.33)$$

Next, another set of new coordinates (u, v, w) are introduced and the relationship between these coordinates and (5.33) is such that

$$\begin{pmatrix} u \\ v \\ w \end{pmatrix} = \begin{pmatrix} 0 & 1 & 0 \\ -3/(\pi\alpha) & 0 & 1 \\ 3/(\pi\alpha) & 0 & 0 \end{pmatrix} \begin{pmatrix} X \\ Y \\ Z \end{pmatrix}. \quad (5.34)$$

This diagonalises the stability matrix. With appropriate substitutions for (X, Y, Z) , the dynamical system is now governed by a new set of autonomous differential equations \dot{u}, \dot{v} and \dot{w} which can be found using the chain rule

$$\dot{u} = \dot{X} \frac{\partial u}{\partial X} + \dot{Y} \frac{\partial u}{\partial Y} + \dot{Z} \frac{\partial u}{\partial Z}, \quad (5.35)$$

$$\dot{v} = \dot{X} \frac{\partial v}{\partial X} + \dot{Y} \frac{\partial v}{\partial Y} + \dot{Z} \frac{\partial v}{\partial Z}, \quad (5.36)$$

$$\dot{w} = \dot{X} \frac{\partial w}{\partial X} + \dot{Y} \frac{\partial w}{\partial Y} + \dot{Z} \frac{\partial w}{\partial Z}. \quad (5.37)$$

The linear part of the new system in matrix form reads

$$\begin{pmatrix} -3 & 0 & 0 \\ 0 & 0 & 0 \\ 0 & 0 & \alpha - 3 \end{pmatrix}, \quad (5.38)$$

However, this is not yet in the right form and therefore, yet another change of variables is necessary. In particular, \dot{u} and \dot{v} should be swapped, thereby changing the dummy coordinate variables as $u \rightarrow v$ and $v \rightarrow u$ with w remaining unchanged. In these coordinates, our system of equations is now in the correct form

$$\begin{pmatrix} \dot{u} \\ \dot{v} \\ \dot{w} \end{pmatrix} = \begin{pmatrix} 0 & 0 & 0 \\ 0 & -3 & 0 \\ 0 & 0 & \alpha - 3 \end{pmatrix} \begin{pmatrix} u \\ v \\ w \end{pmatrix} + \begin{pmatrix} \text{non} \\ \text{linear} \\ \text{terms} \end{pmatrix}. \quad (5.39)$$

Comparing this with the general form (2.13), we firstly note that $x = u$ is a scalar function while $y = (v, w)$ is a two-component vector. Accordingly, it

is obvious to find that

$$A = 0, \quad (5.40)$$

$$B = \begin{pmatrix} -3 & 0 \\ 0 & \alpha - 3 \end{pmatrix}, \quad (5.41)$$

$$f = -\frac{1}{6}\pi\alpha(6 + \sqrt{6}\lambda)uw - \frac{3}{2}u^3 - \frac{1}{6}\pi^2\alpha^2uw^2 - \sqrt{\frac{3}{2}}u\lambda \left(1 + (u^2 - 1) \tan \left[\frac{1}{2}\pi \left(\frac{1}{2} + v + w \right) \right] \right), \quad (5.42)$$

$$g = \begin{pmatrix} g_1 \\ g_2 \end{pmatrix} = \begin{pmatrix} (\alpha + 2a_2\pi\alpha - 3)u^2 + 3a_3u^3 + \mathcal{O}(u^4) \\ (3 + 2b_2\pi\alpha)u^2 + b_3(3 - \alpha)u^3 + \mathcal{O}(u^4) \end{pmatrix}. \quad (5.43)$$

According to Theorem 2.4, the centre manifold can now be assumed to be of the form

$$h = \begin{pmatrix} g_1 \\ g_2 \end{pmatrix} = \begin{pmatrix} a_2u^2 + a_3u^3 + \mathcal{O}(u^4) \\ b_2u^2 + b_3u^3 + \mathcal{O}(u^4) \end{pmatrix}. \quad (5.44)$$

It has to satisfy the equation (2.23), which explicitly reads

$$\mathcal{N} = \frac{1}{2\pi\alpha} \begin{pmatrix} 3(\alpha + 2a_2\pi\alpha - 3)u^2 + 3a_3u^3 + \mathcal{O}(u^4), \\ (3 - \alpha)(3 + 2b_2\pi\alpha)u^2 + b_3(3 - \alpha)u^3 + \mathcal{O}(u^4), \end{pmatrix} = 0. \quad (5.45)$$

The explicit expressions for g_1 and g_2 are

$$g_1 = \frac{1}{6} \left(\frac{9}{\pi} + 18(v + w) + 3w\alpha(1 + 3\pi w) + \pi^2w^3\alpha^2 + \frac{27}{\pi(3 + \pi w\alpha)} - \frac{6}{\pi}(3 \cos[\pi(v + w)] - (3 + \pi w\alpha) \sin[\pi(v + w)]) \right) + \frac{3}{2}u^2w - \frac{9}{2\pi(3 + \pi w\alpha)} + \frac{u^2}{2\pi\alpha} \left(9 - 3\sqrt{6}\lambda + \sqrt{6}(3 + \pi w\alpha)\lambda \tan \left[\frac{1}{2}\pi \left(\frac{1}{2} + v + w \right) \right] \right), \quad (5.46)$$

$$g_2 = \frac{3u^2((3 - 6\pi w)\alpha - \pi^2 w^2 \alpha^2 - 9)}{2\pi\alpha(3 + \pi w\alpha)} - \frac{1}{\pi\alpha} \sqrt{\frac{3}{2}} u^2 \lambda \left(3 - (3 + \pi w\alpha) \tan \left[\frac{1}{2} \pi \left(\frac{1}{2} + v + w \right) \right] \right) - \frac{\pi w^2 \alpha (27 + 3(1 + 4\pi w)\alpha + \pi^2 w^2 \alpha^2)}{6(3 + \pi w\alpha)}. \quad (5.47)$$

Solving for the four constants a_2, a_3, b_2 and b_3 , we obtain

$$a_2 = \frac{3 - \alpha}{2\pi\alpha}, \quad a_3 = 0, \quad (5.48)$$

$$b_2 = \frac{-3}{2\pi\alpha}, \quad b_3 = 0. \quad (5.49)$$

We can now study the dynamics of the reduced equation (2.16), which becomes

$$\dot{u} = - \left(\frac{3}{2} + \sqrt{\frac{3}{2}} \alpha \right) u^3 + \mathcal{O}(u^4). \quad (5.50)$$

Therefore, we find that the point A_+ is stable according to the centre manifold theory. This calculation has been repeated for A_- and the opposite result was obtained i.e. this point is unstable.

5.4 Conclusion

Centre manifold theory has been applied to study the cosmological system where linear stability fails due to presence of a zero eigenvalue. In doing so, a step-by-step and systematic approach [75] has been taken. At the point B_0 acceleration is possible and it is a scaling solution which would have solved the cosmological coincidence problem, but the fact that it is unstable means that the universe would evolve into the stable point A_+ where $w_{\text{tot}} = -1$ and therefore acceleration is possible at this point. Both A_+ and A_- points are completely dominated by dark energy while in B_0 there is no dark energy. Whilst phase-space might reveal information on the nature of the critical points, it may sometimes give incorrect information if the point in question

is a non-hyperbolic point. The results obtained above by applying the centre manifold theory appear contradicting with what may be revealed from phase-space plots. Thus, it becomes clear that we need to perform non-linear stability analysis, especially when there is a zero eigenvalue resulting from the system linearised about a point. When a non-minimal coupling between three-form fields and the dark matter comes into existence, the system has two extra critical points, but these points were not analysed. But the fact that B_0 disappears in the coupled model and degenerates into B_{\pm} could mean that in this model the degree of dark energy domination is affected by the energy transfer rate. This model does not reveal information on matter domination, nor does it give rise to scaling solutions to solve the cosmological coincidence problem.

6 Interacting Phantom Dark Energy

6.1 Introduction

Phantom dark energy models exhibit interesting features. They can be generated by a simple scalar field with a negative kinetic energy [31]. Its equation of state parameter is almost $w = -1$ and it seems to be consistent with observational data [96, 97]. The action of the phantom field minimally coupled to gravity is given by [14]

$$S = \int d^4x \sqrt{-g} \left[\frac{1}{2} (\nabla\varphi)^2 - V(\varphi) \right]. \quad (6.1)$$

The energy density and the pressure of the field is given by

$$\rho_\varphi = -\frac{1}{2}\dot{\varphi}^2 + V(\varphi), \quad (6.2)$$

$$p_\varphi = -\frac{1}{2}\dot{\varphi}^2 - V(\varphi). \quad (6.3)$$

The value of the equation of state parameter can be smaller than -1; this means

$$w_\varphi = \frac{p}{\rho} = \frac{\dot{\varphi}^2 + 2V(\varphi)}{\dot{\varphi}^2 - 2V(\varphi)} < -1, \quad (6.4)$$

provided that

$$\dot{\varphi}^2/2 < V(\varphi). \quad (6.5)$$

When equation (6.4) holds, which is indeed the case if the potential is of exponential form [98], the scalar field generating the dark energy is said to be in the phantom regime and hence the name phantom field models. The phantom fields induce vacuum instabilities which make research on these models very challenging [31]. Furthermore, they suffer severe ultra-violet (UV) quantum instabilities. Just like as in previously presented work on quintessence interacting with dark matter, interacting phantom energy models may possibly solve the cosmological coincidence problem [99–106].

6.2 Phantom Dark Energy Coupled to Dark Matter with Varying-mass

In a recent paper by Leon & Saridakis [107] a scenario in which dark energy is attributed to a phantom field and interacting with a varying-mass model for dark matter particles [50, 108–110] has been investigated. They considered a phantom dark energy model with power-law potential [111] interacting with dark matter. The model from [107] (whose explicit formulation is presented below) has been investigated as part of this thesis for two reasons. Firstly, the dynamical system constructed will yield a zero eigenvalue when linearised about one of its physically meaningful critical points [107]. Therefore we can explore the possibility of applying the centre manifold theory to this model. Secondly the model has good physical motivation. Under the assumption that dark energy and dark matter interact in a way that allows the dark particles to gain mass depending on the scalar field which reproduces dark energy [108], makes this model appear to have better physical justification and with strong theoretical basis. Some of these models can be well-motivated from string theory or scalar-tensor theories where mass variations appear quite naturally [112].

When it is assumed that dark energy is attributed to a phantom field, then the equation of the state parameter is given by

$$w_{\text{DE}} \equiv w_{\varphi} = \frac{p_{\varphi}}{\rho_{\varphi}}. \quad (6.6)$$

The energy density for dark matter whose mass is a function of the scalar field is defined as [107]

$$\rho_{\text{DM}} = M_{\text{DM}}(\varphi)n_{\text{DM}}, \quad (6.7)$$

where n_{DM} is the number density of the dark matter which satisfies the following conservation equation

$$\dot{n}_{\text{DM}} + 3Hn_{\text{DM}} = 0, \quad (6.8)$$

H is the usual Hubble constant.

The potential and the mass of the dark matter depending on the scalar

field are assumed to be of the forms [107]

$$V(\varphi) = V_0\varphi^\lambda, \quad (6.9)$$

$$M_{\text{DM}} = M_0\varphi^\mu, \quad (6.10)$$

respectively, where λ and μ are dimensionless constants.

The fact that the mass of the dark matter depends on the scalar field gives rise to the existence of interactions (or couplings) between the two. This implies that when the mass of the dark matter does not depend on the field, the standard conservation equation for the energy density given by

$$\dot{\rho}_{\text{DM}} + 3H\rho_{\text{DM}} = 0,$$

is satisfied. In the field-dependent case, however, the balance equations are given by

$$\dot{\rho}_{\text{DM}} + 3H\rho_{\text{DM}} = Q, \quad (6.11)$$

$$\dot{\rho}_\varphi + 3H(\rho_\varphi + p_\varphi) = -Q, \quad (6.12)$$

where

$$Q = \frac{d \ln M_{\text{DM}}(\varphi)}{d\varphi} \dot{\varphi} \rho_{\text{DM}}, \quad (6.13)$$

and the sign of Q determines the direction of energy transfer.

The other evolution equations and the modified Klein-Gordon equation governing the evolution of the phantom field are given by

$$H^2 = \frac{\kappa^2}{3} (\rho_\varphi + \rho_{\text{DM}}), \quad (6.14)$$

$$\dot{H} = -\frac{\kappa^2}{2} (\rho_\varphi + p_\varphi + \rho_{\text{DM}}), \quad (6.15)$$

$$\ddot{\varphi} + 3H\dot{\varphi} - \frac{\partial V(\varphi)}{\partial \varphi} = \frac{1}{M_{\text{DM}}(\varphi)} \frac{dM_{\text{DM}}(\varphi)}{d\varphi} \rho_{\text{DM}}. \quad (6.16)$$

Neglecting the baryons and radiation, the total energy density of the universe is then the sum of the dark matter and the phantom

$$\rho_{\text{tot}} = \rho_{\text{DM}} + \rho_\varphi,$$

which satisfies the conservation equation given by

$$\dot{\rho}_{\text{tot}} + 3H(1 + w_{\text{tot}})\rho_{\text{tot}} = 0, \quad (6.17)$$

with

$$w_{\text{tot}} = \frac{p_{\varphi}}{\rho_{\varphi} + \rho_{\text{DM}}} = w_{\varphi}\Omega_{\varphi}, \quad (6.18)$$

where

$$\Omega_{\varphi} \equiv \frac{\rho_{\varphi}}{\rho_{\text{tot}}} = \Omega_{\text{DE}}. \quad (6.19)$$

Similar to previous work, dimensionless dynamical variables have been defined [107] as follows

$$x := \frac{\kappa\dot{\varphi}}{\sqrt{6}H}, \quad (6.20)$$

$$y := \frac{\kappa\sqrt{V(\varphi)}}{\sqrt{3}H}, \quad (6.21)$$

$$z := \frac{\sqrt{6}}{\kappa\varphi}. \quad (6.22)$$

It is useful to express the density parameter and the equation of state in form of these variables, which gives

$$\Omega_{\varphi} = \frac{\kappa^2\rho_{\varphi}}{3H^2} = -x^2 + y^2, \quad (6.23)$$

$$w_{\varphi} = \frac{x^2 + y^2}{x^2 - y^2}, \quad (6.24)$$

$$w_{\text{tot}} = -x^2 - y^2. \quad (6.25)$$

In these variable, the cosmological field equations take the form of the following dynamical system

$$x' = -3x + \frac{3}{2}x(1 - x^2 - y^2) - \frac{\lambda y^2 z}{2} - \frac{\mu}{2}z(1 + x^2 - y^2), \quad (6.26)$$

$$y' = \frac{3}{2}y(1 - x^2 - y^2) - \frac{\lambda xyz}{2}, \quad (6.27)$$

$$z' = -xz^2, \quad (6.28)$$

where λ and μ are dimensionless constants.

This system possess two physically meaningful critical points which are non-hyperbolic since there exists at least one zero eigenvalue in each of them, see Table 14.

Point	x	y	z	eigenvalues	w_φ	w_{tot}
A	0	0	0	$0, 3/2, -3/2$	undefined	0
B	0	1	0	$0, -3, -3$	-1	-1

Table 14: Critical points of the phantom dark energy model.

6.3 Application of the Centre Manifold Theory to Phantom Dark Energy Model

Clearly the point A is always unstable since there is one positive and one negative eigenvalue. As for the point B , there are two negative eigenvalues and a zero eigenvalue. Therefore, linear stability theory fails to provide information about that point and structural stability is no longer guaranteed. Consequently, non-linear stability techniques must be exploited, either by applying the centre manifold approach or by applying the methods of normal form. Similar procedure has been carried out in the three-form model. We closely followed [75].

Firstly, the coordinates of critical point B are changed so that it is moved to the origin

$$X = x, \tag{6.29}$$

$$Y = y - 1, \tag{6.30}$$

$$Z = z. \tag{6.31}$$

The linear matrix of the system becomes

$$\begin{pmatrix} -3 & 1 & -\frac{\lambda}{2} \\ 0 & -3 & 0 \\ 0 & 0 & 0 \end{pmatrix}, \tag{6.32}$$

whose eigenvectors are

$$\begin{pmatrix} 0 \\ 1 \\ 0 \end{pmatrix}, \begin{pmatrix} 1 \\ 0 \\ 0 \end{pmatrix}, \begin{pmatrix} 0 \\ \frac{\lambda}{6} \\ 1 \end{pmatrix}. \quad (6.33)$$

Thus, we introduce another new set of coordinates which will diagonalise the matrix.

$$\begin{pmatrix} u \\ v \\ w \end{pmatrix} = \begin{pmatrix} 0 & 1 & 0 \\ 1 & 0 & \frac{\lambda}{6} \\ 0 & 0 & 1 \end{pmatrix} \begin{pmatrix} X \\ Y \\ Z \end{pmatrix}. \quad (6.34)$$

in new coordinate system. As expected, the stability matrix at the origin is obtained as

$$\begin{pmatrix} -3 & 0 & 0 \\ 0 & -3 & 0 \\ 0 & 0 & 0 \end{pmatrix}, \quad (6.35)$$

The equations are not quite in the right form which is an issue not dissimilar to the one encountered in the case of three-forms in the previous chapter. Thus, by performing change of dummy variables as $u \rightarrow v$ and $w \rightarrow u$, with v remaining unchanged, we finally arrive at

$$\begin{pmatrix} \dot{u} \\ \dot{v} \\ \dot{w} \end{pmatrix} = \begin{pmatrix} 0 & 0 & 0 \\ 0 & -3 & 0 \\ 0 & 0 & -3 \end{pmatrix} \begin{pmatrix} u \\ v \\ w \end{pmatrix} + \begin{pmatrix} \text{non} \\ \text{linear} \\ \text{terms} \end{pmatrix}. \quad (6.36)$$

As before, the system is compared against the general form (2.13) and it is deduced that $x = u$ is a scalar function while $y = (v, w)$ is a two-component

vector. Thus, we deduce

$$A = 0, \quad (6.37)$$

$$B = \begin{pmatrix} -3 & 0 \\ 0 & -3 \end{pmatrix}, \quad (6.38)$$

$$f = -\frac{1}{6}u^2(6v - u\lambda), \quad (6.39)$$

$$g = \begin{pmatrix} g_1 \\ g_2 \end{pmatrix}. \quad (6.40)$$

The explicit expressions of the components of g are

$$\begin{aligned} g_1 = & -\frac{3}{2}v(v^2 + w(2 + w)) + \frac{1}{4}u(w(2 + w)(2\mu - \lambda) + v^2(3\lambda - 2\mu)) \\ & - \frac{1}{24}u^2v\lambda(4 + 3\lambda - 4\mu) + \frac{1}{144}u^3\lambda^2(4 + \lambda - 2\mu), \end{aligned} \quad (6.41)$$

and

$$g_2 = -\frac{3}{2}(v^2(1 + w) + w^2(3 + w)) + \frac{1}{24}u^2(1 + w)\lambda^2. \quad (6.42)$$

The centre manifold can now be assumed to be of the form

$$h = \begin{pmatrix} g_1 \\ g_2 \end{pmatrix} = \begin{pmatrix} a_2u^2 + a_3u^3 + \mathcal{O}(u^4) \\ b_2u^2 + b_3u^3 + \mathcal{O}(u^4) \end{pmatrix}. \quad (6.43)$$

The function h must satisfy the equation (2.23) which reads

$$\mathcal{N} = \begin{pmatrix} 3a_2u^2 + \frac{1}{144}u^3(432a_3 + 72b_2(\lambda - 2\mu) - \lambda^2(4 + \lambda - 2\mu)) + \mathcal{O}(u^4) \\ 3b_3u^3 + u^2\left(3b_2 - \frac{\lambda^2}{24}\right) + \mathcal{O}(u^4) \end{pmatrix} = 0. \quad (6.44)$$

where the a_2, a_3, b_2 and b_3 are found to be

$$a_2 = 0, \quad a_3 = \frac{\lambda^2}{108}, \quad (6.45)$$

$$b_2 = \frac{\lambda^2}{72}, \quad b_3 = 0. \quad (6.46)$$

Therefore, the dynamics of the system restricted to the centre manifold

is given by

$$\dot{u} = \frac{u^3 \lambda}{6} + \mathcal{O}(u^4). \quad (6.47)$$

Thus it is clear from the cm equation that the point is stable if $\lambda < 0$ and unstable if $\lambda > 0$ and this result is in consistent with [107] who obtained the same result by applying normal forms [75, 113, 114]. Note that when the value of b_2 is substituted into the first component of \mathcal{N} , the constant μ drops out which is why our result is independent of μ .

6.4 Conclusion

Results obtained in this chapter demonstrate that centre manifold theory is a powerful tool, easily applicable to dynamical systems encountered in cosmology. The next step could be an attempt to investigate whether the models investigated using this technique are physically sensible and/or in agreement with observations. The point investigated is whether acceleration is possible and whether it is dominated by phantom dark energy. However, it does not give a scaling solution to solve the cosmological coincidence problem. Thus the question arises as to whether interacting phantom dark energy models can give rise to evolution of the system starting from unstable point dominated by standard matter and then end up at a point where acceleration is possible and dominated by dark energy which is also a scaling solution, thereby alleviating the cosmological coincidence problem.

7 Discussion, Future Work and Conclusion

In this chapter, we discuss two projects currently in progress which may be continued in the future. They are the standard model Higgs boson non-minimally coupled to gravity and Einstein's static universe. Both are to be studied taking the dynamical systems approach.

7.1 Standard Model Higgs Boson Non-minimally Coupled to Gravity

7.1.1 Introduction

Higgs fields are an important class of scalar fields in theoretical particle physics since they might explain the origin of the mass of elementary particles [115]. The Higgs boson was first postulated by Peter Higgs [116] to explain the mechanism that involves spontaneous symmetry breaking involving a gauge field. This mechanism became known as the Higgs mechanism. The Higgs boson has not yet been discovered and is a hypothetical massive elementary particle. The search for it is still in progress. First data hinting at the existence of the Higgs boson have been found by the LHC. However, more data is required to announce its discovery. In the context of cosmology, Higgs fields were once considered as inflaton fields, a idea originally proposed by Guth. The Standard Model Higgs Boson still remains a fundamental candidate for inflaton. Inflation is usually achieved by considering slowly rolling scalar fields but this is not possible if the Higgs Boson is minimally coupled to gravity [117]. Therefore, non-minimal couplings of the Higgs field to gravity have been postulated [118, 119]. It has also been suggested that the Higgs boson may interact with WIMPs (which include dark matter) [120], making this particle even more relevant to cosmology.

A new model of slow-roll Higgs inflation, which is a unique non-minimal derivative coupling of the Standard Model Higgs boson to gravity has been considered in [121]. The model is said to propagate no more degree of freedom than general relativity sourced by a scalar field. It seems to feature interesting behaviour since it gives rise to inflating background solutions within the parameter range of the Standard Model Higgs fields, while avoiding the need

for quantum corrections.

Under the assumption that there is no interaction with gauge fields during inflation, the action for the case in which Higgs boson minimally coupled to gravity is given by [121]

$$\mathcal{S} = \int dt a^3 \left[-3 \frac{H^2}{\kappa^2 N} + \frac{1}{2} \frac{\dot{\varphi}^2}{N} - N \frac{\lambda}{4} \varphi^4 \right], \quad (7.1)$$

while that for the case in which Higgs boson non-minimally couples to gravity is given by

$$\mathcal{S} = \int dt a^3 \left[-3 \frac{H^2}{\kappa^2 N} + \frac{1}{2} \frac{\dot{\varphi}^2}{N} + \frac{3}{2} \frac{H^2 w^2}{N^3} \dot{\varphi}^2 - N \frac{\lambda}{2} \varphi^4 \right], \quad (7.2)$$

where $N = N(t)$ is the lapse.

The Hamiltonian constraint and the field equations for non-minimally coupled case are respectively given by

$$H^2 = \frac{\kappa^2}{6} \left[\dot{\varphi}^2 (1 + 9H^2 w^2) + \frac{\lambda}{2} \varphi^4 \right], \quad (7.3)$$

and

$$\partial_t [a^3 \dot{\varphi} (1 + 3H^2 w^2)] = -a^3 \lambda \varphi^3, \quad (7.4)$$

where the w term describes scalar field interactions with gravity. From the above, the modified Klein-Gordon equation is derived as

$$\ddot{\varphi} + 3H\dot{\varphi} + \frac{6H\dot{H}\dot{\varphi}w^2}{1 + 3H^2w^2} + \frac{\lambda\varphi^3}{1 + 3H^2w^2} = 0, \quad (7.5)$$

assuming there is no interaction with ordinary or dark matter. Should there be a general interaction Q , equation (7.5) would become

$$\ddot{\varphi} + 3H\dot{\varphi} + \frac{6H\dot{H}\dot{\varphi}w^2}{1 + 3H^2w^2} + \frac{\lambda\varphi^3}{1 + 3H^2w^2} = \frac{Q}{1 + 3H^2w^2}, \quad (7.6)$$

and again the sign of Q would dictate the direction of the energy transfer.

7.1.2 Constructing a Dynamical System and Failure of Centre Manifold Analysis

Similar to the work presented in previous sections, a dynamical systems approach has been taken to investigate the nature of this field generating dark energy which is also coupled to gravity in specific way. In order to construct a dynamical system, the Friedmann constraint (7.3) was first solved to obtain an expression for Hubble's constant

$$H = \kappa \sqrt{\frac{\lambda\varphi^4 + 2\dot{\varphi}^2}{12 - 18w^2\kappa^2\dot{\varphi}^2}}. \quad (7.7)$$

Squaring both sides of equation (7.7) and the dividing it with H^2 results in

$$1 = \frac{\kappa^2\dot{\varphi}^2}{3(2 - 3w^2\kappa^2\dot{\varphi}^2)H^2} + \frac{\kappa^2\lambda\varphi^4}{6(2 - 3w^2\kappa^2\dot{\varphi}^2)H^2}, \quad (7.8)$$

so that dimensionless the variables x and y can be defined such that

$$x^2 = \frac{\kappa^2\dot{\varphi}^2}{3(2 - 3w^2\kappa^2\dot{\varphi}^2)H^2}, \quad (7.9)$$

$$y^2 = \frac{\kappa^2\lambda\varphi^4}{6(2 - 3w^2\kappa^2\dot{\varphi}^2)H^2}. \quad (7.10)$$

The phase space is then compact since $x^2 + y^2 = 1$.

Similar to the work done previously [56,84], a third dimensionless variable

$$z = \frac{H_0}{H + H_0},$$

has been included. However, this does not increase the number of dimensions to three and the system is still maintained as a 2-dimensional system since $y = \sqrt{1 - x^2}$ which can be eliminated from the system.

By incorporating the modified Klein-Gordon equation together with the expression for \dot{H} obtained by differentiating equation (7.7) with respect to

time, one obtains the following dynamical equations

$$x' = 3x(-1 + x^2) + \frac{18x^3(-1 + x^2)(-1 + z)^2\alpha^2}{z^2} + \left(\frac{2 \cdot 3^{1/4}(1 - x^2)^{3/4}\sqrt{z}}{\sqrt{1 - z}} + \frac{3 \cdot 3^{1/4}(1 - x^2)^{3/4}(-4 + x^2)(1 - z)^{3/2}\alpha^2}{2z^{3/2}} \right) \Gamma, \quad (7.11)$$

$$z' = 3x^2(-1 + z)z, \quad (7.12)$$

where new constants α and Γ have been introduced, defined such that

$$w = \frac{\alpha}{H_0}, \quad (7.13)$$

$$\lambda = \Gamma^4 \kappa^2 H_0^2. \quad (7.14)$$

The α terms in the equations, therefore, encodes interactions of the scalar field with gravity in the case of non-minimal couplings. Setting $\alpha = 0$ for simplicity if there is no such interactions, then the equations become

$$x' = -3x + 3x^3 - 2 \cdot 3^{1/4}(1 - x^2)^{3/4} \sqrt{\frac{z}{1 - z}} \Gamma, \quad (7.15)$$

$$z' = -3x^2(-1 + z)z. \quad (7.16)$$

The variable y has been eliminated using $y = \sqrt{1 - x^2}$. The critical points of the system are $(x, z) = (0, 0)$, $(1, 0)$ and $(1, 1)$. The eigenvalues of the Jacobi matrix linearised about the point $(0, 0)$ are -3 and 0 and therefore non-linear stability analysis is necessary to determine whether it is stable or not. As before centre manifold analysis has been performed. However, it has been noticed along the process that the expression for the nonlinear part of the system does not satisfy the condition given by equation (2.14), which reads

$$\begin{aligned} f(0, 0) &= 0, & Df(0, 0) &= 0, \\ g(0, 0) &= 0, & Dg(0, 0) &= 0. \end{aligned}$$

Note that this is the consequence of the term $\sqrt{\frac{z}{1-z}}$ from equation (7.15)

which is not differentiable at the critical points. Therefore, dynamical systems approach to this particular model is met with difficulties and it demonstrates limitations of the techniques that have been employed so far in this thesis. Whilst numerical analysis and simulation similar to that performed in [87] may be a solution to solve this problem, this was not pursued in this thesis since the main focus is on analytical and not numerical studies of the dynamical systems theory. In this regard, applying the method of normal forms [75, 114], which is a technique to eliminate the nonlinearity of the system, may be an alternative solution to overcome this problem. This method is briefly discussed, but its employment is beyond the scope of this thesis and its applications in cosmology may be foreseen as something to be done in the future.

7.2 Einstein's Static universe

7.2.1 Introduction

Our understanding of the dynamics of the universe today is largely due to the success of the theory of general relativity. Just like Newtonian mechanics, which successfully describes the dynamics of macroscopic objects but breaks down when it has to deal with subatomic particles whose behaviour is dominated by quantum effects, the same is true with GR in a sense that while it can successfully describe the large scale behaviour of the universe it breaks down at small scale. At very small scales and after a finite time of backward evolution, GR can no longer describe the behaviour of the system. This is due to the fact that the universe collapses to a single point at Big Bang, which is the problem known as singularity, and the energy densities become divergent. Thus, the need for quantum gravity appears important in this regard. One way of overcoming these singularity problems may be a new framework of so-called loop quantum cosmology [122]. Loop quantum gravity is a proposed theory that seeks to unify quantum theory and GR. If successful, loop quantum gravity may become quantum theory of space-time. Loop quantum cosmology may also be thought of as a high energy modifications of GR which can lead towards uncovering the mathematically

interesting properties of the universe in this context [123]. This owes to the fact that high energy dynamics of the FLRW models are modified in loop quantum cosmology. Furthermore, it has the advantage such that it removes the Big Bang singularity [124] or the singularity at the centre of a black hole, see e.g. [125]. It has been known that the Einstein Static universe in GR is unstable with respect to homogeneous perturbations. The Einstein static universe takes a very special role in studying the behaviour of the universe, for instance in emergent universe scenarios (which is possible if curvature is positive) and in dealing with singularity problems in the standard model.

7.2.2 Studying Einstein Static Universe as a Dynamical System

The Friedmann equation for closed FLRW model is given by [126]

$$H_{\text{LQ}}^2 = \left(\frac{\kappa}{3}\rho + \frac{\Lambda}{3} - \frac{1}{a^2} \right) \left(1 - \frac{\rho}{\rho_{\text{crit}}} - \frac{\Lambda}{\kappa\rho_{\text{crit}}} + \frac{3}{\kappa\rho_{\text{crit}}a^2} \right). \quad (7.17)$$

The above is the modification of the classical Friedmann equation to take into account the loop quantum effects which are characterised by a critical energy density. In the GR limit, the critical density ρ_{crit} tends to infinity. Thus, the second term approaches unity in GR limit, in which case the Friedmann equation takes its standard form

$$H_{\text{GR}}^2 = \left(\frac{\kappa}{3}\rho + \frac{\Lambda}{3} - \frac{1}{a^2} \right). \quad (7.18)$$

The conservation equation for energy density ρ holds irrespective of the corrections due to loop quantum gravity and for loop quantum case. It is given by

$$\dot{\rho} + 3H\rho(1+w) = 0. \quad (7.19)$$

Together with equations (7.17) and (7.19), it results in a modified Raychaudhuri equation

$$\begin{aligned} \dot{H} = & -\frac{\kappa}{\rho}(1+w) \left(1 - \frac{2\rho}{\rho_{\text{crit}}} - \frac{2\Lambda}{\kappa\rho_{\text{crit}}} \right) \\ & + \left[1 - \frac{2\rho}{\rho_{\text{crit}}} - \frac{2\Lambda}{\kappa\rho_{\text{crit}}} - \frac{3\rho(1+w)}{\rho_{\text{crit}}} \right] \frac{1}{a^2} + \frac{6}{\kappa\rho_{\text{crit}}a^4}. \end{aligned} \quad (7.20)$$

These equations fully determine the dynamical behaviour of the universe. Viewing equations (7.19) and (7.20) as a dynamical system, we find that one of the critical points of it in loop quantum cosmology is a centre of the linearised system, as suggested from Figure 17. However, it cannot imply that it is also the centre of the entire nonlinear system [75, 113]⁸. This is also obvious from the fact that the Jacobi matrix linearised about this point yields a pair of purely imaginary eigenvalues (see [123] for details). It is likely that this system would give rise to bifurcation phenomena which leads towards the opportunity to apply the theory of bifurcations to address cosmological issues [127]. The role of this theory in cosmological context have been studied in [128].

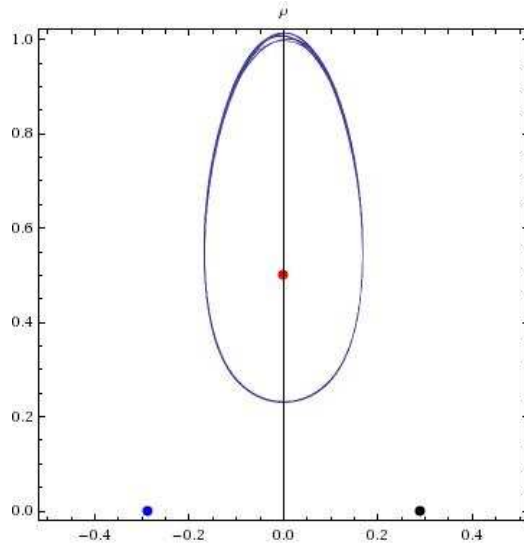

Figure 17: Dynamical behaviour of the system around the LQ critical point for the case $\Lambda > \kappa\rho_c$ with $\Lambda/\kappa = 2, w = 1$.

With this established, based on the present literature [123, 129–131], and given that it also has a role to interplay with $f(R)$ modified gravity theories [132] it is expected that Einstein static universe in different scenarios will lead to construction of dynamical systems enriched with interesting behaviour and cosmological dynamics.

⁸Note that this centre is not related to centre manifolds.

7.3 Conclusion

In this thesis, mathematical properties and cosmological implications of various dynamical dark energy models have been studied by applying various techniques. All models have their strengths and shortcomings. Physically realistic and motivated models often become mathematically complicated and computationally demanding. The ultimate goal is to construct a model that is in close agreement with current observational data or future observational data due to be obtained. Observations confirm the models and on the other hand the models give ideas of what should be looked for in observations. It has been shown that Model \mathcal{B} of the quintessence model studied in Chapter 4 does not admit a standard matter era in its evolution. Thus, it is reasonable to discard the model from future investigations. In Model \mathcal{C} , on the other hand, there exists an unstable matter era point which evolves into an attractor point which is dominated by dark energy and where acceleration is possible. Thus, this model is of potential interest for further investigation.

Applying dynamical systems theory is not always trivial. In Chapters 5 and 6, it has been demonstrated systematically how centre manifold theory can be applied to the study of the dynamical systems that give rise to zero eigenvalues when their Jacobi matrix is linearised about certain critical points. In most physical systems modelled as dynamical systems, they are usually restricted to mathematically simple models. More realistic physical systems can become mathematically very complicated and powerful computational tools and resources are required to investigate such systems. The case in which centre manifold theory successfully reveals the nature of a non-hyperbolic critical point in the three-form model, in contrast to that revealed by phase-space plot, has been demonstrated. This shows the need for non-linear stability analysis. How to perform this have been demonstrated explicitly in order to reveal the structural stability of such points. However, centre manifold theory does not appear to be a universal tool to be able to solve nonlinear dynamical systems. It has its own limitations as seen in the case of the Higgs field coupled to gravity as discussed in part of Chapter 7. This issue requires further investigation. In fact, centre manifold theory,

which has been studied in this thesis, is not the only tool to overcome the case of zero eigenvalues. For example, numerical analysis and second order perturbation theory may also be applied to study the structural stability of the critical points whose corresponding eigenvalues include a zero, which could be performed in investigating the three-forms models [87]. Attempts to find Lyapunov’s functions for the critical points where linear stability theory have been made. Given that there is, unfortunately, to our knowledge so far, no systematic way of finding these functions and that the equations involved are relatively long expressions prevented us from finding one. It is also possible that there simply does not exist such functions for the critical point concerned. Thus analysing the critical points by finding Lyapunov functions may be useful only for relatively simple systems.

In Chapter 5, it has been shown that in the dynamical system in question, the critical points are born and their stability may change with respect to a parameter. Creation and destruction of critical points and their parameter-dependent nature of (in)stabilities fall under the study of mathematical area called “bifurcation theory” [75]. Thus, in the future, bifurcations in cosmological dynamical systems and application of the method of normal forms in this context may be explored. It is expected that such techniques may reveal interesting cosmological dynamics of the systems.

As far as achieving a late-time acceleration scenario, dominated by dark energy, and a scaling solution are concerned, it may well be concluded that certain quintessence models may be better physically motivated than others like varying-mass power-law potential phantom dark energy models.

In this thesis, interacting dark energy models have been studied under the assumption that dark energy is indeed responsible for the late-time accelerated expansion of the universe. The possibility that it contributes towards the growth of cosmological perturbations should not be ruled out. Thus, in more physically well-motivated and realistic models, the effects of cosmological perturbations should also be taken into account. Consequently, the dynamical system incorporating the time-evolution of cosmological perturbations would be computationally demanding to investigate and might reveal some interesting mathematical and physical properties and behaviour. What

dark energy really is remains to be discovered experimentally and/or observationally with proper theoretical foundations. Furthermore, as discussed earlier, dark energy is not the only possible explanation for the accelerated expansion of the universe. Whilst it may well be directly responsible the universe's accelerated expansion, alternative theories exist to explain the accelerated expansion of the universe without reference to dark energy or any other form of matter. They include, but are not limited to, $f(R)$ modified gravity theories, scalar-tensor theories, DGP braneworld models etc. It is important to take into account the perturbations in modified gravity theories as they reveal the features that enable us to distinguish between modified gravity models and dark energy models.

It is expected that in future work more advanced techniques from the theory of dynamical systems could be applied to study the models of the universe in $f(R)$ gravity to understand the accelerated expansion of the universe (as an alternative to dark energy models) and its dynamics in general. The stability analysis performed in this regard as far as this thesis is concerned is "local" in a sense that only the nature of the critical points of the system that represents the system has been investigate. In order to get the wider picture and the final state of the universe ultimately, the stability of the entire model in question should be investigated. Beyond the field of mathematical physics, the theory of dynamical systems has applications in many other areas such as mathematical immunology which, for example, studies the complex dynamics of the tumour growth, immune system response to HIV vaccinations etc.

Whilst there is a huge amount of mathematical literature on the modern theory of dynamical systems, which remains a relatively young field, much of this still awaits to be applied to problems in theoretical physics. Dynamical systems theory itself is at the cross-road of pure mathematics and applied mathematics. It was the hope of this thesis that it will play a small role in building a bridge between the ever increasingly blurring boundaries of the two fields - applied mathematics and theoretical physics. With this established, it is foreseeable that more mathematical tools will be explored to uncover their potential power when applied to physics.

References

- [1] **Supernova Search Team** Collaboration, A. G. Riess *et al.*, “Observational Evidence from Supernovae for an Accelerating Universe and a Cosmological Constant,” *Astron. J.* **116** (1998) 1009–1038, [arXiv:astro-ph/9805201](#).
- [2] **Supernova Cosmology Project** Collaboration, S. Perlmutter *et al.*, “Measurements of Omega and Lambda from 42 High-Redshift Supernovae,” *Astrophys. J.* **517** (1999) 565–586, [arXiv:astro-ph/9812133](#).
- [3] **Supernova Search Team** Collaboration, J. L. Tonry *et al.*, “Cosmological results from high-z supernovae,” *Astrophys. J.* **594** (2003) 1–24, [arXiv:astro-ph/0305008](#) [astro-ph].
- [4] A. R. Liddle, *An Introduction to Modern Cosmology*. Wiley, 2003.
- [5] E. Hubble, “A Relation between Distance and Radial Velocity among Extra-Galactic Nebulae,” *Proceedings of the National Academy of Sciences* **15** (1929) 168–173.
- [6] **HST** Collaboration, W. L. Freedman *et al.*, “Final Results from the Hubble Space Telescope Key Project to Measure the Hubble Constant,” *Astrophys. J.* **553** (2001) 47–72, [arXiv:astro-ph/0012376](#).
- [7] A. G. Riess *et al.*, “A Redetermination of the Hubble Constant with the Hubble Space Telescope from a Differential Distance Ladder,” *Astrophys. J.* **699** (2009) 539–563, [arXiv:0905.0695](#) [astro-ph.CO].
- [8] F. Beutler *et al.*, “The 6dF Galaxy Survey: Baryon Acoustic Oscillations and the Local Hubble Constant,” [arXiv:1106.3366](#) [astro-ph.CO].

- [9] **WMAP** Collaboration, C. L. Bennett *et al.*, “First year Wilkinson Microwave Anisotropy Probe (WMAP) observations: Preliminary maps and basic results,” *Astrophys.J.Suppl.* **148** (2003) 1, [arXiv:astro-ph/0302207](#) [astro-ph].
- [10] R. Durrer, *The Cosmic Microwave Background*. Cambridge University Press, 2008.
- [11] P. J. E. Peebles, *Principles of Physical Cosmology*. Princeton University Press, 1993.
- [12] A. Einstein, “Cosmological considerations in the General Theory of Relativity,” *Sitzungsber. Preuss. Akad. Wiss. Phys.-math. Klasse VI* (1917) 142.
- [13] S. Dodelson, *Modern Cosmology*. Academic Press, Elsevier Science, 2003.
- [14] E. J. Copeland, M. Sami, and S. Tsujikawa, “Dynamics of dark energy,” *Int. J. Mod. Phys. D***15** (2006) 1753–1936, [arXiv:hep-th/0603057](#).
- [15] **WMAP** Collaboration, D. N. Spergel *et al.*, “Wilkinson Microwave Anisotropy Probe (WMAP) three year results: Implications for cosmology,” *Astrophys. J. Suppl.* **170** (2007) 377, [arXiv:astro-ph/0603449](#).
- [16] G. Bertone, D. Hooper, and J. Silk, “Particle dark matter: Evidence, candidates and constraints,” *Phys. Rept.* **405** (2005) 279–390, [arXiv:hep-ph/0404175](#).
- [17] F. Zwicky, “Die Rotverschiebung von extragalaktischen Nebeln,” *Helvetica Physica Acta* **6** (1933) 110–127.
- [18] F. Zwicky, “On the Masses of Nebulae and of Clusters of Nebulae,” *Astrophysical Journal* **86** (Oct., 1937) 217–+.

- [19] Y. Mellier, “Cosmological Applications of Gravitational Lensing,”
arXiv:astro-ph/9901116.
- [20] G. Jungman, M. Kamionkowski, and K. Griest, “Supersymmetric
dark matter,” *Phys.Rept.* **267** (1996) 195–373,
arXiv:hep-ph/9506380 [hep-ph].
- [21] G. B. Gelmini, “Search for Dark Matter,” *Int.J.Mod.Phys.* **A23**
(2008) 4273–4288, arXiv:0810.3733 [hep-ph].
- [22] N. Fornengo, “Status and perspectives of indirect and direct dark
matter searches,” *Adv.Space Res.* **41** (2008) 2010–2018,
arXiv:astro-ph/0612786 [astro-ph].
- [23] G. Bertone, “Dark Matter: A Multidisciplinary Approach,”
arXiv:0710.5603 [astro-ph].
- [24] A. R. Liddle and D. H. Lyth, *Cosmological Inflation and Large-Scale
Structure*. Cambridge University Press, 2000.
- [25] **AMANDA** Collaboration, P. Niessen *et al.*, “Recent results from the
AMANDA experiment,” arXiv:astro-ph/0306209.
- [26] P. Jain, *Topics in Ultra-cold Bose Gases: the Bose-Hubbard Model;
Analogue Models for an Expanding Universe and for an Acoustic
Black Hole*. PhD thesis, Victoria University of Wellington, 2007.
- [27] S. M. Carroll, “The Cosmological constant,” *Living Rev.Rel.* **4** (2001)
1, arXiv:astro-ph/0004075 [astro-ph].
- [28] P. Peebles and B. Ratra, “The Cosmological constant and dark
energy,” *Rev.Mod.Phys.* **75** (2003) 559–606,
arXiv:astro-ph/0207347 [astro-ph].
- [29] C. Wetterich, “Cosmology and the Fate of Dilatation Symmetry,”
Nucl.Phys. **B302** (1988) 668.

- [30] B. Ratra and P. Peebles, “Cosmological Consequences of a Rolling Homogeneous Scalar Field,” *Phys.Rev.* **D37** (1988) 3406.
- [31] R. R. Caldwell, “A Phantom Menace?,” *Phys. Lett.* **B545** (2002) 23–29, [arXiv:astro-ph/9908168](#).
- [32] T. Chiba, T. Okabe, and M. Yamaguchi, “Kinetically driven quintessence,” *Phys.Rev.* **D62** (2000) 023511, [arXiv:astro-ph/9912463](#) [astro-ph].
- [33] C. Armendariz-Picon, V. F. Mukhanov, and P. J. Steinhardt, “A Dynamical solution to the problem of a small cosmological constant and late time cosmic acceleration,” *Phys.Rev.Lett.* **85** (2000) 4438–4441, [arXiv:astro-ph/0004134](#) [astro-ph].
- [34] C. Armendariz-Picon, V. F. Mukhanov, and P. J. Steinhardt, “Essentials of k essence,” *Phys.Rev.* **D63** (2001) 103510, [arXiv:astro-ph/0006373](#) [astro-ph].
- [35] T. Padmanabhan, “Accelerated expansion of the universe driven by tachyonic matter,” *Phys.Rev.* **D66** (2002) 021301, [arXiv:hep-th/0204150](#) [hep-th].
- [36] T. Padmanabhan and T. R. Choudhury, “Can the clustered dark matter and the smooth dark energy arise from the same scalar field?,” *Phys.Rev.* **D66** (2002) 081301, [arXiv:hep-th/0205055](#) [hep-th].
- [37] A. Y. Kamenshchik, U. Moschella, and V. Pasquier, “An Alternative to quintessence,” *Phys.Lett.* **B511** (2001) 265–268, [arXiv:gr-qc/0103004](#) [gr-qc].
- [38] N. Bilic, G. B. Tupper, and R. D. Viollier, “Unification of dark matter and dark energy: The Inhomogeneous Chaplygin gas,” *Phys.Lett.* **B535** (2002) 17–21, [arXiv:astro-ph/0111325](#) [astro-ph].
- [39] M. Bento, O. Bertolami, and A. A. Sen, “Generalized Chaplygin gas, accelerated expansion and dark energy matter unification,” *Phys.Rev.* **D66** (2002) 043507, [arXiv:gr-qc/0202064](#) [gr-qc].

- [40] C. G. Böhrer and J. Burnett, “Dark Spinors,” [arXiv:1001.1141](#) [gr-qc].
- [41] C. G. Böhrer and J. Burnett, “Dark energy with dark spinors,” *Mod.Phys.Lett.* **A25** (2010) 101–110, [arXiv:0906.1351](#) [gr-qc].
- [42] C. G. Böhrer and T. Harko, “Dark energy as a massive vector field,” *Eur.Phys.J.* **C50** (2007) 423–429, [arXiv:gr-qc/0701029](#) [gr-qc].
- [43] A. H. Guth, “The Inflationary Universe: A Possible Solution to the Horizon and Flatness Problems,” *Phys.Rev.* **D23** (1981) 347–356.
- [44] S. Tsujikawa, “Introductory review of cosmic inflation,” [arXiv:hep-ph/0304257](#) [hep-ph].
- [45] P. J. Fox, R. Harnik, J. Kopp, and Y. Tsai, “Missing Energy Signatures of Dark Matter at the LHC,” [arXiv:1109.4398](#) [hep-ph].
- [46] C. Wetterich, “The Cosmon model for an asymptotically vanishing time dependent cosmological ‘constant’,” *Astron.Astrophys.* **301** (1995) 321–328, [arXiv:hep-th/9408025](#) [hep-th].
- [47] L. Amendola, “Scaling solutions in general nonminimal coupling theories,” *Phys.Rev.* **D60** (1999) 043501, [arXiv:astro-ph/9904120](#) [astro-ph].
- [48] A. P. Billyard and A. A. Coley, “Interactions in scalar field cosmology,” *Phys.Rev.* **D61** (2000) 083503, [arXiv:astro-ph/9908224](#) [astro-ph].
- [49] W. Zimdahl and D. Pavon, “Interacting quintessence,” *Phys.Lett.* **B521** (2001) 133–138, [arXiv:astro-ph/0105479](#) [astro-ph].
- [50] G. R. Farrar and P. J. E. Peebles, “Interacting dark matter and dark energy,” *Astrophys.J.* **604** (2004) 1–11, [arXiv:astro-ph/0307316](#) [astro-ph].

- [51] L. P. Chimento, A. S. Jakubi, D. Pavon, and W. Zimdahl, “Interacting quintessence solution to the coincidence problem,” *Phys.Rev.* **D67** (2003) 083513, arXiv:astro-ph/0303145 [astro-ph].
- [52] G. Olivares, F. Atrio-Barandela, and D. Pavon, “Observational constraints on interacting quintessence models,” *Phys.Rev.* **D71** (2005) 063523, arXiv:astro-ph/0503242 [astro-ph].
- [53] H. M. Sadjadi and M. Alimohammadi, “Cosmological coincidence problem in interactive dark energy models,” *Phys.Rev.* **D74** (2006) 103007, arXiv:gr-qc/0610080 [gr-qc].
- [54] Z.-K. Guo, N. Ohta, and S. Tsujikawa, “Probing the Coupling between Dark Components of the Universe,” *Phys.Rev.* **D76** (2007) 023508, arXiv:astro-ph/0702015 [ASTRO-PH].
- [55] K. Y. Kim, H. W. Lee, and Y. S. Myung, “Holographic interacting dark energy in the braneworld cosmology,” *Mod.Phys.Lett.* **A22** (2007) 2631–2645, arXiv:0706.2444 [gr-qc].
- [56] C. G. Böhrer, G. Caldera-Cabral, R. Lazkoz, and R. Maartens, “Dynamics of dark energy with a coupling to dark matter,” *Phys.Rev.* **D78** (2008) 023505, arXiv:0801.1565 [gr-qc].
- [57] J.-H. He and B. Wang, “Effects of the interaction between dark energy and dark matter on cosmological parameters,” *JCAP* **0806** (2008) 010, arXiv:0801.4233 [astro-ph].
- [58] S. Chen, B. Wang, and J. Jing, “Dynamics of interacting dark energy model in Einstein and Loop Quantum Cosmology,” *Phys.Rev.* **D78** (2008) 123503, arXiv:0808.3482 [gr-qc].
- [59] M. Quartin, M. O. Calvao, S. E. Joras, R. R. R. Reis, and I. Waga, “Dark Interactions and Cosmological Fine-Tuning,” *JCAP* **0805** (2008) 007, arXiv:0802.0546 [astro-ph].

- [60] S. H. Pereira and J. F. Jesus, “Can Dark Matter Decay in Dark Energy?,” *Phys.Rev.* **D79** (2009) 043517, [arXiv:0811.0099](#) [astro-ph].
- [61] C. Quercellini, M. Bruni, A. Balbi, and D. Pietrobon, “Late universe dynamics with scale-independent linear couplings in the dark sector,” *Phys.Rev.* **D78** (2008) 063527, [arXiv:0803.1976](#) [astro-ph].
- [62] J. Valiviita, E. Majerotto, and R. Maartens, “Instability in interacting dark energy and dark matter fluids,” *JCAP* **0807** (2008) 020, [arXiv:0804.0232](#) [astro-ph].
- [63] D. J. Holden and D. Wands, “Selfsimilar cosmological solutions with a nonminimally coupled scalar field,” *Phys.Rev.* **D61** (2000) 043506, [arXiv:gr-qc/9908026](#) [gr-qc].
- [64] L. Amendola and S. Tsujikawa, *Dark Energy: Theory and Observations*. Cambridge University Press, 2010.
- [65] G. Caldera-Cabral, *Interacting Dark Energy Models of the Late-Time acceleration of the Universe*. PhD thesis, The University of Portsmouth, 2009.
- [66] P. G. Ferreira and M. Joyce, “Cosmology with a Primordial Scaling Field,” *Phys. Rev.* **D58** (1998) 023503, [arXiv:astro-ph/9711102](#).
- [67] A. De Felice and S. Tsujikawa, “ $f(R)$ theories,” *Living Rev.Rel.* **13** (2010) 3, [arXiv:1002.4928](#) [gr-qc].
- [68] T. P. Sotiriou and V. Faraoni, “ $f(R)$ Theories Of Gravity,” *Rev. Mod. Phys.* **82** (2010) 451–497, [arXiv:0805.1726](#) [gr-qc].
- [69] K. K. Yerzhanov, S. R. Myrzakul, I. I. Kulnazarov, and R. Myrzakulov, “Accelerating cosmology in $F(T)$ gravity with scalar field,” [arXiv:1006.3879](#) [gr-qc].
- [70] R. A. Battye, M. Bucher, and D. Spergel, “Domain wall dominated universes,” [arXiv:astro-ph/9908047](#) [astro-ph].

- [71] R. D. Sorkin, “Forks in the road, on the way to quantum gravity,” *Int.J.Theor.Phys.* **36** (1997) 2759–2781, [arXiv:gr-qc/9706002](#) [gr-qc].
- [72] S. Kachru, R. Kallosh, A. D. Linde, and S. P. Trivedi, “De Sitter vacua in string theory,” *Phys.Rev.* **D68** (2003) 046005, [arXiv:hep-th/0301240](#) [hep-th].
- [73] V. Faraoni, “ $f(R)$ gravity: successes and challenges,” [arXiv:0810.2602](#) [gr-qc].
- [74] K. T. Alligood, T. D. Sauer, and J. A. Yorke, *CHAOS: An Introduction to Dynamical Systems*. Springer, 1996.
- [75] S. Wiggins, *Introduction to Applied Nonlinear Dynamical Systems and Chaos*. Springer, 1990.
- [76] A. M. Velasquez-Toribio, “Stability in a class of quartessence models,” *Braz. J. Phys.* **36** (2006) 772–776.
- [77] C. G. Böhrer and T. Harko, “Nonlinear stability analysis of the Emden-Fowler equation,” *Journal of Nonlinear Mathematical Physics* **17** (2010) 503–516, [arXiv:0902.1054](#) [math-ph].
- [78] J. Carr, *Applications of centre manifold theory*. Springer, 1981.
- [79] E. J. Copeland, A. R. Liddle, and D. Wands, “Exponential potentials and cosmological scaling solutions,” *Phys. Rev.* **D57** (1998) 4686–4690, [arXiv:gr-qc/9711068](#).
- [80] J.-Q. Xia and M. Viel, “Early Dark Energy at High Redshifts: Status and Perspectives,” *JCAP* **0904** (2009) 002, [arXiv:0901.0605](#) [astro-ph.CO].
- [81] B. Zwiebach, *A First Course in String Theory*. Cambridge University Press, 2004.

- [82] P. J. E. Peebles and B. Ratra, “Cosmology with a Time Variable Cosmological Constant,” *Astrophys. J.* **325** (1988) L17.
- [83] P. J. Steinhardt, L.-M. Wang, and I. Zlatev, “Cosmological tracking solutions,” *Phys. Rev.* **D59** (1999) 123504, [arXiv:astro-ph/9812313](#).
- [84] C. G. Böhrer, G. Caldera-Cabral, N. Chan, R. Lazkoz, and R. Maartens, “Quintessence with quadratic coupling to dark matter,” *Phys.Rev.* **D81** (2010) 083003, [arXiv:0911.3089 \[gr-qc\]](#).
- [85] G. Caldera-Cabral, R. Maartens, and L. A. Urena-Lopez, “Dynamics of interacting dark energy,” *Phys.Rev.* **D79** (2009) 063518, [arXiv:0812.1827 \[gr-qc\]](#).
- [86] G. Caldera-Cabral, R. Maartens, and B. M. Schaefer, “The Growth of Structure in Interacting Dark Energy Models,” *JCAP* **0907** (2009) 027, [arXiv:0905.0492 \[astro-ph.CO\]](#).
- [87] T. S. Koivisto and N. J. Nunes, “Inflation and dark energy from three-forms,” *Phys. Rev.* **D80** (2009) 103509, [arXiv:0908.0920 \[astro-ph.CO\]](#).
- [88] T. S. Koivisto and N. J. Nunes, “Three-form cosmology,” *Phys. Lett.* **B685** (2010) 105–109, [arXiv:0907.3883 \[astro-ph.CO\]](#).
- [89] A. D. Rendall, “Cosmological models and centre manifold theory,” *Gen. Rel. Grav.* **34** (2002) 1277–1294, [arXiv:gr-qc/0112040](#).
- [90] T. Ngampitipan and P. Wongjun, “Dynamics of three-form dark energy with dark matter couplings,” [arXiv:1108.0140 \[hep-ph\]](#).
- [91] O. Hrycyna and M. Szydlowski, “Uniting cosmological epochs through the twister solution in cosmology with non-minimal coupling,” *JCAP* **1012** (2010) 016, [arXiv:1008.1432 \[astro-ph.CO\]](#).
- [92] L. H. Ford, “Inflation driven by a vector field,” *Phys. Rev.* **D40** (1989) 967.

- [93] T. S. Koivisto, D. F. Mota, and C. Pitrou, “Inflation from N-Forms and its stability,” *JHEP* **09** (2009) 092, [arXiv:0903.4158](#) [[astro-ph.CO](#)].
- [94] C. Germani and A. Kehagias, “P-nflation: generating cosmic Inflation with p-forms,” *JCAP* **0903** (2009) 028, [arXiv:0902.3667](#) [[astro-ph.CO](#)].
- [95] C. G. Böhrer, N. Chan, and R. Lazkoz, “Dynamics of dark energy models and centre manifolds,” [arXiv:1111.6247](#) [[gr-qc](#)].
- [96] P. S. Corasaniti, M. Kunz, D. Parkinson, E. J. Copeland, and B. Bassett, “The Foundations of observing dark energy dynamics with the Wilkinson Microwave Anisotropy Probe,” *Phys.Rev.* **D70** (2004) 083006, [arXiv:astro-ph/0406608](#) [[astro-ph](#)].
- [97] U. Alam, V. Sahni, T. D. Saini, and A. A. Starobinsky, “Is there supernova evidence for dark energy metamorphosis?,” *Mon.Not.Roy.Astron.Soc.* **354** (2004) 275, [arXiv:astro-ph/0311364](#) [[astro-ph](#)].
- [98] M. Sami and A. Toporensky, “Phantom field and the fate of universe,” *Mod.Phys.Lett.* **A19** (2004) 1509, [arXiv:gr-qc/0312009](#) [[gr-qc](#)].
- [99] Z.-K. Guo, R.-G. Cai, and Y.-Z. Zhang, “Cosmological evolution of interacting phantom energy with dark matter,” *JCAP* **0505** (2005) 002, [arXiv:astro-ph/0412624](#) [[astro-ph](#)].
- [100] A. Nunes, J. P. Mimoso, and T. C. Charters, “Scaling solutions from interacting fluids,” *Phys.Rev.* **D63** (2001) 083506, [arXiv:gr-qc/0011073](#) [[gr-qc](#)].
- [101] N. J. Nunes and D. F. Mota, “Structure formation in inhomogeneous dark energy models,” *Mon.Not.Roy.Astron.Soc.* **368** (2006) 751–758, [arXiv:astro-ph/0409481](#) [[astro-ph](#)].

- [102] T. Clifton and J. D. Barrow, “The Ups and downs of cyclic universes,” *Phys.Rev.* **D75** (2007) 043515, [arXiv:gr-qc/0701070](#) [gr-qc].
- [103] X.-M. Chen, Y.-G. Gong, and E. N. Saridakis, “Phase-space analysis of interacting phantom cosmology,” *JCAP* **0904** (2009) 001, [arXiv:0812.1117](#) [gr-qc].
- [104] Z.-K. Guo and Y.-Z. Zhang, “Interacting phantom energy,” *Phys.Rev.* **D71** (2005) 023501, [arXiv:astro-ph/0411524](#) [astro-ph].
- [105] R. Curbelo, T. Gonzalez, and I. Quiros, “Interacting phantom energy and avoidance of the big rip singularity,” *Class.Quant.Grav.* **23** (2006) 1585–1602, [arXiv:astro-ph/0502141](#) [astro-ph].
- [106] T. Gonzalez and I. Quiros, “Exact models with non-minimal interaction between dark matter and (either phantom or quintessence) dark energy,” *Class.Quant.Grav.* **25** (2008) 175019, [arXiv:0707.2089](#) [gr-qc].
- [107] G. Leon and E. N. Saridakis, “Phantom dark energy with varying-mass dark matter particles: acceleration and cosmic coincidence problem,” *Phys. Lett.* **B693** (2010) 1–10, [arXiv:0904.1577](#) [gr-qc].
- [108] G. W. Anderson and S. M. Carroll, “Dark matter with time dependent mass,” [arXiv:astro-ph/9711288](#) [astro-ph].
- [109] J. Casas, J. Garcia-Bellido, and M. Quiros, “Scalar - tensor theories of gravity with phi dependent masses,” *Class.Quant.Grav.* **9** (1992) 1371–1384, [arXiv:hep-ph/9204213](#) [hep-ph].
- [110] M. B. Hoffman, “Cosmological constraints on a dark matter - dark energy interaction,” [arXiv:astro-ph/0307350](#) [astro-ph].
- [111] X. Zhang, “Coupled quintessence in a power-law case and the cosmic coincidence problem,” *Mod.Phys.Lett.* **A20** (2005) 2575, [arXiv:astro-ph/0503072](#) [astro-ph].

- [112] T. Damour, G. W. Gibbons, and C. Gundlach, “Dark matter, time varying G , and a dilaton field,” *Phys.Rev.Lett.* **64** (1990) 123–126.
- [113] D. K. Arrowsmith and C. M. Place, *An Introduction to Dynamical Systems*. Cambridge University Press, 1990.
- [114] A. H. Nayfeh, *The Method of Normal Forms*. Wiley, 2011.
- [115] B. W. Lee, C. Quigg, and H. B. Thacker, “Weak interactions at very high energies: The role of the higgs-boson mass,” *Phys. Rev. D* **16** (Sep, 1977) 1519–1531.
<http://link.aps.org/doi/10.1103/PhysRevD.16.1519>.
- [116] P. W. Higgs, “Broken symmetries and the masses of gauge bosons,” *Phys. Rev. Lett.* **13** (Oct, 1964) 508–509.
<http://link.aps.org/doi/10.1103/PhysRevLett.13.508>.
- [117] A. D. Linde, “Chaotic Inflation,” *Phys. Lett.* **B129** (1983) 177–181.
- [118] J. L. Cervantes-Cota and H. Dehnen, “Induced gravity inflation in the standard model of particle physics,” *Nucl.Phys.* **B442** (1995) 391–412, [arXiv:astro-ph/9505069](https://arxiv.org/abs/astro-ph/9505069) [astro-ph].
- [119] F. L. Bezrukov and M. Shaposhnikov, “The Standard Model Higgs boson as the inflaton,” *Phys.Lett.* **B659** (2008) 703–706, [arXiv:0710.3755](https://arxiv.org/abs/0710.3755) [hep-th].
- [120] C. B. Jackson, G. Servant, G. Shaughnessy, T. M. P. Tait, and M. Taoso, “Higgs in Space!,” *JCAP* **1004** (2010) 004, [arXiv:0912.0004](https://arxiv.org/abs/0912.0004) [hep-ph].
- [121] C. Germani and A. Kehagias, “New Model of Inflation with Non-minimal Derivative Coupling of Standard Model Higgs Boson to Gravity,” *Phys. Rev. Lett.* **105** (2010) 011302, [arXiv:1003.2635](https://arxiv.org/abs/1003.2635) [hep-ph].
- [122] M. Bojowald, “Loop quantum cosmology,” *Living Rev.Rel.* **8** (2005) 11, [arXiv:gr-qc/0601085](https://arxiv.org/abs/gr-qc/0601085) [gr-qc].

- [123] L. Parisi, M. Bruni, R. Maartens, and K. Vandersloot, “The Einstein static universe in Loop Quantum Cosmology,” *Class.Quant.Grav.* **24** (2007) 6243–6254, [arXiv:0706.4431](#) [gr-qc].
- [124] M. Bojowald, “Absence of singularity in loop quantum cosmology,” *Phys.Rev.Lett.* **86** (2001) 5227–5230, [arXiv:gr-qc/0102069](#) [gr-qc].
- [125] C. G. Böhrer and K. Vandersloot, “Loop Quantum Dynamics of the Schwarzschild Interior,” *Phys.Rev.* **D76** (2007) 104030, [arXiv:0709.2129](#) [gr-qc].
- [126] A. Ashtekar, T. Pawłowski, and P. Singh, “Quantum nature of the big bang,” *Phys.Rev.Lett.* **96** (2006) 141301, [arXiv:gr-qc/0602086](#) [gr-qc].
- [127] J. Wainwright and G. F. R. Ellis, *Dynamical Systems in Cosmology*. Cambridge University Press, 1997.
- [128] E. W. Mielke, F. V. Kusmartsev, and F. E. Schunck, “Inflation, bifurcations of nonlinear curvature Lagrangians and dark energy,” [arXiv:0704.1135](#) [gr-qc].
- [129] S. Carneiro and R. Tavakol, “Stability of the Einstein static universe in presence of vacuum energy,” *Phys.Rev.* **D80** (2009) 043528, [arXiv:0907.4795](#) [astro-ph.CO].
- [130] J. D. Barrow, G. F. R. Ellis, R. Maartens, and C. G. Tsagas, “On the stability of the Einstein static universe,” *Class.Quant.Grav.* **20** (2003) L155–L164, [arXiv:gr-qc/0302094](#) [gr-qc].
- [131] R. Canonico and L. Parisi, “Stability of the Einstein Static Universe in open cosmological models,” *Phys.Rev.* **D82** (2010) 064005, [arXiv:1005.3673](#) [gr-qc].
- [132] C. G. Böhrer, L. Hollenstein, F. S. N. Lobo, and S. S. Seahra, “Stability of the Einstein static universe in modified theories of gravity,” [arXiv:1001.1266](#) [gr-qc].