

# Congenital Amusia: Is there a group with selective rhythm impairments?

Jacques Launay

**FOR  
REFERENCE ONLY**

**Dual Masters in Brain & Mind Sciences  
2007/08**

Supervisor: Lauren Stewart, Goldsmiths College, University of London

Submitted in partial fulfillment of the requirements for the MSc in Brain and Mind  
Sciences July 2008

UMI Number: U593809

All rights reserved

INFORMATION TO ALL USERS

The quality of this reproduction is dependent upon the quality of the copy submitted.

In the unlikely event that the author did not send a complete manuscript and there are missing pages, these will be noted. Also, if material had to be removed, a note will indicate the deletion.



UMI U593809

Published by ProQuest LLC 2013. Copyright in the Dissertation held by the Author.  
Microform Edition © ProQuest LLC.

All rights reserved. This work is protected against  
unauthorized copying under Title 17, United States Code.



ProQuest LLC  
789 East Eisenhower Parkway  
P.O. Box 1346  
Ann Arbor, MI 48106-1346

## Acknowledgements

Many thanks go to Lauren for supporting me with this project and helping me get my foot in the door. Thanks to Guy too, for being ready to save me when I do something stupid! And to Manon for the use of her exquisite rhythms. Also to all the people that were willing to give us helpful advice throughout the project – Tommi Himberg, Martine Turgeon, Bruno Repp, Mick Grierson, Rob Davies, Patrick Nasralla and everyone else that helped along the way...

### Statement of Contributors:

Study design: Jacques Launay, Lauren Stewart, Manon Grube

Study Programming: Jacques Launay with advice from Mick Grierson

Recruitment: Jacques Launay, Guy Peryer, Lauren Stewart

Data Collection: Jacques Launay

Data Analysis: Jacques Launay with advice from Constantinos Kallis

Write-up: Jacques Launay

## **Contents**

Abstract .....	4
1. Introduction .....	5
1.1 Music and the Brain .....	6
1.2 Congenital Amusia and the Montreal Battery for the Evaluation of Amusia .....	10
1.3 Sensorimotor synchronization – Rhythm Production in Tapping tasks .....	15
1.3.1 Models of SMS .....	15
1.3.2 Spontaneous tapping .....	17
1.3.3 Synchronisation-continuation tasks .....	18
1.4 Current Study .....	20
2. Methods .....	25
3 Results .....	27
3.1 MBEA .....	27
3.2 Tapping tasks .....	28
3.2.1 Spontaneous tapping task .....	28
3.2.2 Continuation task .....	30
3.2.3 Synchronisation task .....	32
3.2.4 Dysrhythmic comparison .....	38
4 Discussion .....	43
4.1 MBEA .....	43
4.2 Tapping Tasks .....	45
4.2.1 Spontaneous tapping rate .....	45
4.2.2 Continuation task .....	45
4.2.3 Synchronisation task .....	47
4.3 Limitations .....	51
4.4 Conclusions .....	54
References .....	55
Apendices .....	60

### **Abbreviations:**

HG	-	Heschl's Gyrus
PAC	-	Primary Auditory Cortex
MBEA	-	Montreal Battery of Evaluation of Amusia
SMS	-	Sensorimotor synchronization
NART	-	National Adult Reading Test
ITI	-	Intertap Interval

## **Abstract**

Congenital amusia has been described as a pitch specific, musical processing deficit. This study aims to identify a subset of this group who suffer from congenital rhythm processing problems, with preserved pitch processing. It uses the Montreal Battery of Evaluation of Amusia to select this group. A tapping task is then used in order to establish how a rhythm perception deficit might affect rhythm production skills. This task involves spontaneous tapping, synchronization with auditory stimuli, and a continuation task. It uses changes in rhythm and pitch for increased complexity across trials and to establish patterns of deficits across the dysrhythmic group. 3 dysrhythmic subjects were identified and 38 controls were also tested. No difference was found between the groups in the spontaneous and continuation conditions. Large amounts of variance in the control data made it hard to compare the two groups effectively in the synchronization task. One observed difference was that dysrhythmics tapped at a different hierarchical level from controls when attempting to synchronise with complex rhythms. The study did successfully identify a small group of dysrhythmics and was able to draw some inferences about the patterns of their deficit.

## **1.Introduction**

Music plays an important role in everyday life for people from all cultures. Despite this ubiquitous nature, it is hard to identify a clear purpose for it, and this means music has often been overlooked by scientific study. This paradoxical position, of being poorly studied because little is known, is currently being improved through the identification of biological processes underlying musical abilities in humans.

The neuroscience of music is a developing field, and much progress is currently being made into understanding normal and abnormal music perception. It is already known to be dissociable from many similar functions of the brain (such as language) and arguably has some independent evolutionary basis (e.g. Wallin, Merker and Brown 2000). This means it can develop as a field of study in its own right and the investigation into people that lack musical capabilities is an important development in the field.

The current study aims to expand knowledge about abnormal musical processing by identifying a group of people with selective congenital rhythm processing impairments in the absence of any pitch processing problems. This group has not been studied before and it has been suggested that they do not exist.

## **1.1 Music and the Brain**

Neuropsychological techniques (looking at abnormal brain functioning) have been very useful in identifying dissociations between different aspects of music cognition. The first important point to note is that musical sounds are processed in a different way from other sounds. This has been found in numerous patient studies reviewed by Griffiths, Rees and Green, (1999). 'Pure amusia' in the absence of any other impairments is now a well established concept. Perhaps most important are cases that demonstrate preserved language functioning with impaired musical processing and vice versa (e.g. Piccirilli, Sciarma, and Luzzi, 2000; Mendez, 2001; Pearce, 2005). These observed differences have led to the identification of some neural correlates of music perception, showing general bias towards musical processing over language in auditory regions of the right hemisphere compared with left (Zatorre, Belin, and Penhune 2002).

The primary auditory cortex (PAC) is located in Heschl's Gyrus (HG) which runs laterally and anteriorly in the Sylvian fissure in the superior temporal lobe (Griffiths, 2003). It can be identified by its cytoarchitecture and can vary considerably in size between individuals (between 30% and 80% of HG can be taken up with PAC). Simple sounds with no need for pitch processing primarily activate this area and the planae temporale, and introduction of pitch leads to increased brain activation in lateral parts of HG (Patterson, Uppenkamp, Johnsrude, and Griffiths, 2002).

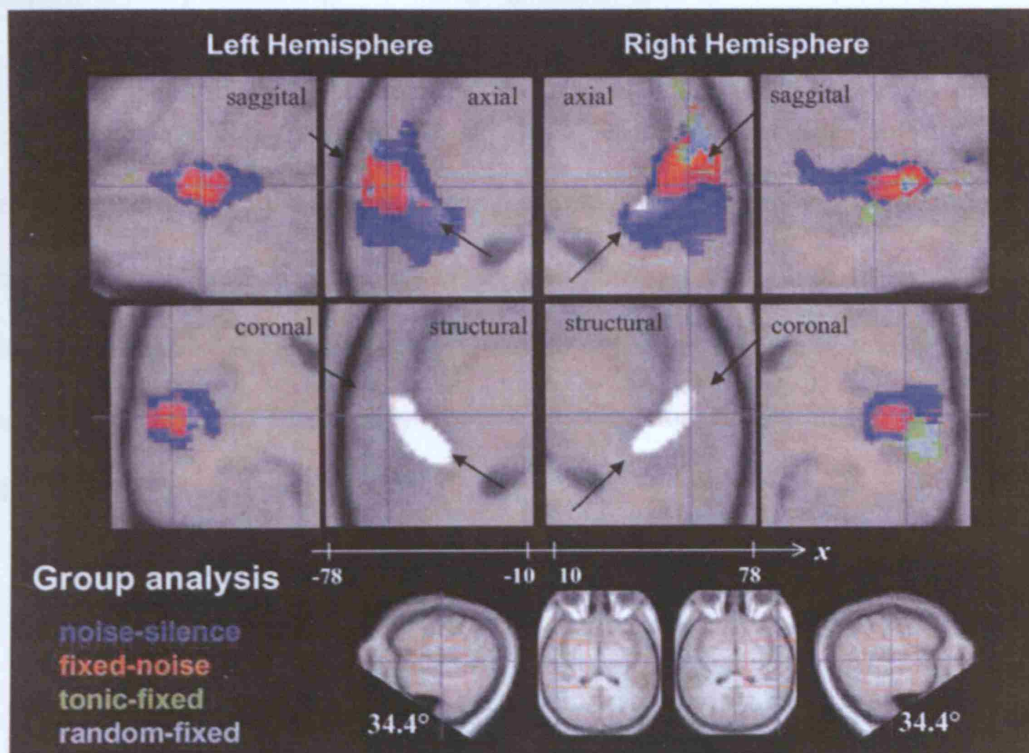

Figure 1. Brain activation in four subjects during different musical listening conditions. The white highlight shows the location of HG. Position and orientation of the sections is illustrated in the bottom panels. Copied from p.770 Patterson et al (2002).

Increased musical complexity involving melody leads to more widespread activation of the temporal lobe, areas of the frontal lobe due to working memory load (Zatorre et al, 2002), as well as other diverse brain regions depending on the kind of processing required.

There are also now a number of documented cases of selective impairments in different aspects of musical processing (Liegeois-Chauvel, de Graaf, Laguitton, and Chauvel, 1998), leading to the suggestion that there are a number of separate modules for different aspects of processing (Peretz and Coltheart, 2003). Most relevant to this paper is the dissociation between rhythm and pitch processing. For example, Murayama, Kashiwagi, Kashiwagi and Mimura (2004) describe a patient who showed



noticeably worse pitch tuning when singing following a right hemispheric infarction, but still demonstrated very good rhythmic skills when singing. Conversely, Di Pietro, Lagnaro, Leeman, and Schneider (2004) describe a musician who suffered from selective rhythm deficits with preserved pitch processing following a left temporo-parietal lesion. Moreover, in this case it was shown that rhythm processing was preserved in the visual modality, suggesting that it did not involve a general temporal processing impairment but a very specific dysfunction in rhythms processed via auditory pathways.

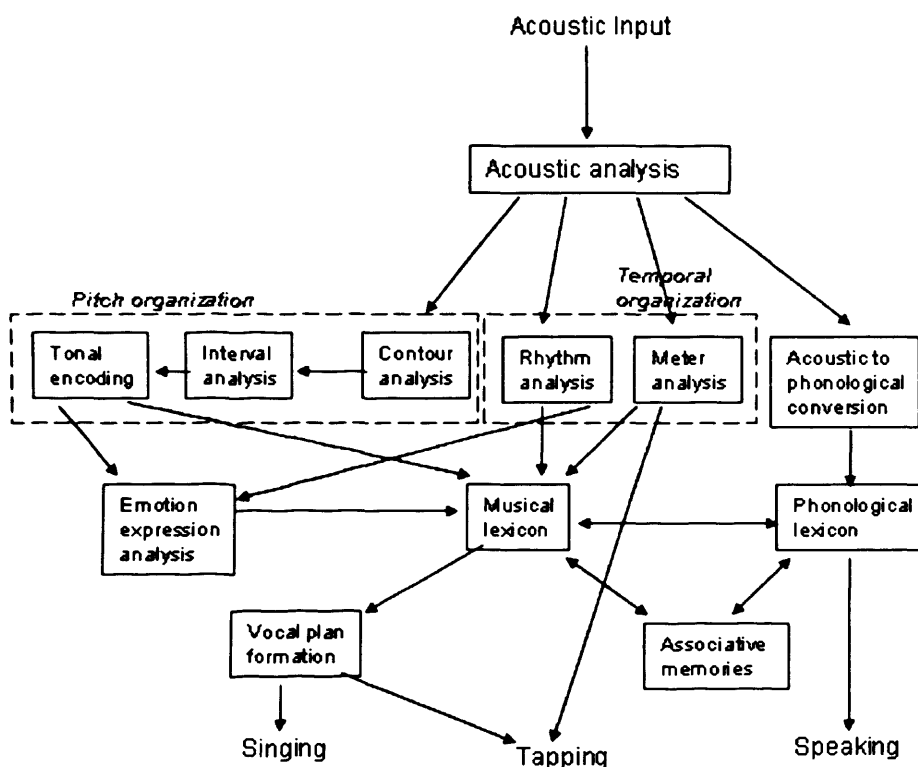

Figure 2. A schematic showing distinct neuropsychological components involved in musical processing. Copied from p. 2534 Stewart, von Kreigstein, Warren, and Griffiths, 2006 (based on Peretz and Coltheart, 2003).

Cases such as these have led to the suggestion that while pitch processing is primarily a right temporal lobe function, some rhythm processing may be done independently of this. Zatorre et al (2002) have argued that the left auditory cortices have greater sensitivity to fast temporal events, which allows them to play a vital role in speech

perception. This suggests that rhythm changes can be more effectively monitored in this region too. This is supported by patient studies mentioned above, in which left temporal lobe damage is more likely to result in rhythm processing deficits, and also by studies using implanted electrodes which show greater sensitivity to brief temporal differences in the left PAC (Liegeois-Chauvel, Peretz, Babai, Laguitton, and Chauvel, 1998), and greater sensitivity to pitch discrimination in the right PAC (Liegeois-Chauvel, Giraud, Badier, Marquis, and Chauvel, 2001).

Rhythm processing has also been shown to involve diverse regions such as the cerebellum and basal ganglia (Penhume, Zatorre, and Evans, 1998; Sakai, Hikosaka, Miyauchi, Takino, Tamada, Iwata, and Nielsen, 1999), which play a more general role in motor timing and control.

This dissociation between rhythm and pitch processing paves the way for further investigation into individual differences in these domains.

## 1.2 Congenital Amusia and the Montreal Battery for the Evaluation of Amusia

The Montreal Battery of Evaluation of Amusia (MBEA) (Peretz, Champod, and Hyde, 2003) was designed following the identification of different musical processing modules listed earlier. It looks at six separate aspects of musical perception - scale, contour, pitch, rhythm, meter, and musical memory. The first three identify pitch discrimination abilities while the next two are about temporal aspects of music, and the final part is a separate musical memory element. Scale is described as the ability to recognise tonality in music - rather than maintaining any *absolute* processing of pitch as a function of pitch height. Contour is recognition of musical shape, i.e. the ability to determine the pattern of increased and decreased pitch values. Pitch is simply the ability to discriminate between the pitches of any two notes. Rhythm is the capacity to group events according to temporal proximity. Meter is concerned with the extraction of an underlying meter or beat. Musical memory is a fairly self-explanatory module that is thought to be an element of memory specific to sequences of music.

Six subtests are used for these different aspects, and these require people to listen to two very short (3.8 - 6.4seconds), monophonic lines of music, one after the other. These two extracts are either exactly the same or have one note difference, and subjects have to say if they are the same or different. There are 15 different musical sequences used in the trials, these are played either matched to an identical sequence, or played matched to a sequence that has one note difference. The subtests involve different changes in the musical sequence relevant to the musical module they are

thought to be testing.

### Stimuli



Figure 3. An example of a musical sequence from the MBEA. The original stimulus is shown as (A), with scale alternative as (B), contour as (C), interval as (D) and rhythm as (E). The position of the changed note is indicated with an asterisk. Adapted from p.63 Peretz et al., 2003.

Development of the MBEA is linked with the description of congenital amusia, a condition in which people that have substantial lifelong deficits in musical perception (Ayotte, Peretz, and Hyde, 2002). This description maps roughly onto people who would be described as ‘tone deaf’ in popular culture, but this term is generally identified by people’s ability to sing - which relates to production of music. The alternative term is used more specifically for people whose problems originate from very poor music perception, so excludes people who simply don’t have the training to control their music production skills.

Peretz and colleagues (2003) suggest that the MBEA is the most effective way of

identifying people who are congenitally amusic. They tested a normal population of 160 people in order to ascertain how people would generally perform and found that a normative model could be applied to the data. People scoring less than 2 standard deviations below the mean were deemed to be impaired on the tests, and this constituted a cut-off score for impairment - this included less than 2% of the normal population in most of the tests.

	Scale	Contour	Interval	Rhythm	Meter	Memory
Mean	27	27	26	27	25	27
S.D.	2.3	2.2	2.4	2.1	3.5	2.3
% of people with perfect score	17	9	7	15	10	10
Cut-off score	22	22	21	23	18	22
% of subjects below cut-off	3	1	1	1	1	1

Figure 4. Summarised scores from 160 control participants in the MBEA. Adapted from p. 66, Peretz et al, 2003.

The test was also applied to 27 people who described themselves as tone deaf, and it was shown that 24 of these scored below the cut off score. The other 3 scored just above the cut off score, which indicates that there is still some variation in ability of people who are aware of musical processing problems.

As this field is still developing, trends have been identified based on a small number of studies. The first three subtests of the MBEA focus on pitch perception, and these were contrasted with performance on the rhythm subtest in order to look at how the two aspects might interact. In the 2003 study, Peretz *et al* noticed that problems with pitch perception were universal in amusic subjects, while rhythm perception only affected a sub-population of these. In effect, this meant amusics in the study did not have impaired rhythm perception with preserved pitch perception. Following this

early discovery, follow ups have been done in order to detect if this is always true of amusic subjects and it has been concluded that this is a general trend, and that congenital amusia simply is a selective pitch impairment (e.g. Peretz and Hyde, 2003; Hyde and Peretz, 2004)

However, there are still some amusic subjects scoring poorly on the rhythm parts of the MBEA. It is therefore argued that as the musical sequences in the MBEA contain both rhythm and pitch changes, the overriding pitch deficits in amusics lead to an impaired ability to process these tunes. A study carried out by Foxton, Nandy and Griffiths in 2006 aimed to look at this possibility. Amusic subjects (identified using the MBEA) were again asked to listen to a pair of musical sequences and detect if there was a lengthened interval in the second sequence or not. These tunes could either be monotonic or have random pitch variations and it was shown that while control subjects did not vary in their ability in these two conditions, amusic subjects were worse in the presence of pitch variation.

Current evidence is equivocal on the view that congenital amusia is a selective impairment in pitch perception. However, this does not reflect findings described earlier from acquired amusia . As acquired amusia has been studied for longer there is more diverse evidence and this has pointed to two different systems within the brain for rhythm and pitch processing.

This might suggest that congenital and acquired cases of amusia take different forms, but it is possible to criticise current studies in congenital cases on the grounds that emphasis was placed on pitch *a priori*. The description of amusia has always been

linked to the popular term 'tone deafness', simply because it gives lay people an easy reference for the term. But tone deafness is itself only a pitch problem. People who have bad rhythm are not identified in popular culture with such a clear cut term and are therefore harder to pick out for study. Studies that advertise for people who self report being amusic are therefore inherently flawed in finding people with specific rhythm deficits. It is possible that the reason there is no term in popular culture for impaired rhythm perception is that these people are far rarer, but this is not sufficient grounds to exclude any possibility of this group existing.

The current study will attempt to improve on the way that amusia has been studied so far by using the MBEA to identify a small group of people that have impaired rhythm processing with preserved pitch perception. As rhythm capability is intimately tied in with motor skills, this study will also check if perceptual difficulties are related to any rhythm production problems.

## **1.3 Sensorimotor synchronization – Rhythm Production in Tapping tasks**

Sensorimotor synchronisation (SMS) is the rhythmic co-ordination of perception and action, and has been studied extensively using tapping tasks (Repp, 2005). These kinds of tasks involve a perceptual cue that participants attempt to synchronise with by tapping on a surface that measures how accurately they are performing. Successful synchronisation to a beat is known as entrainment and cerebellar-premotor networks have been implicated in this ability (Del Olmo et al, 2007). The kind of stimulus provided can vary in a number of different ways, for example participants might just hear a regular isochronous (metronome) beat and tap along exactly in time with this or more complex rhythms can be used, requiring subjects to exactly replicate what they hear, or identify an overriding metre of the music, and entrain to this.

### **1.3.1 Models of SMS**

The influential Wing-Kristofferson (Wing and Kristofferson, 1973a and 1973b) model was developed following the identification of more than one source of variation in tapping ability, and suggests that SMS involves two main systems. The first of these is an internal clock, or timekeeping mechanism, that attempts to maintain a regular beat. The second is a motor implementation process. As both are thought to be variable, serially independent, and independent of one another; there are a number of areas in which error can occur. It has since been suggested that the natural tendency for drift in the internal timekeeping device should also be modelled for (Collier and Ogden, 2004). Given that rhythm perception and production tasks are correlated



(Keele, Porkorny, Corcos, and Ivry, 1985) it seems likely that the central timekeeping device is involved in both of these, but that the motor system is unique to production skills.

It has been noted in several studies that it is possible for people to subconsciously change their tapping in time with a perturbation in the stimulus rate, as well as being able to change rate consciously when they become aware of differences in stimuli (e.g. Repp, 2001). This supports a two tiered model for error correction (Semjen, Schulze and Vorberg, 1998) with an automatic 'phase correction system' which corrects for changes in one beat, and a consciously driven 'period correction system' which involves adjustment of the internal clock (Repp and Keller, 2004). These processes may be supported by different mechanisms in the brain and there is some evidence to suggest that automatic correction can occur in orbitofrontal and prefrontal regions with lateral cerebellar hemispheres, while conscious correction is performed with dorsolateral prefrontal cortex, premotor cortex and posterolateral cerebellum (Stephan, Thaut, Wunderlich, Schicks, Tian, Tellman, Schmitz, Herzog, McIntosh, Seitz, and Homberg 2002; Praamstra, Turgeon, Hesse, Wing, and Perryer, 2003).

Some SMS tasks require identifying an overriding metre of music and synchronising with this. This is quite a natural human activity, a simple example of this being people tapping a foot along to music they are hearing. However, the processes behind this kind of activity can be quite complex. Grouping rhythm correctly requires a set of criteria in order to establish a hierarchy of temporal structure. This can be done by low level grouping of beats that are temporally close (rhythmic grouping), using pitches in music to identify rhythmic structure (melodic accent), or using larger

temporal grouping based on absolute time (metric accent) (Drake and Palmer, 1993). It is also possible that perceptual tendencies of the listener can have an effect on what is deemed to be the correct metre found in a complex rhythm (meter preference rule) (Lerdahl and Jackendoff, 1983).

### **1.3.2 Spontaneous tapping.**

Spontaneous tapping tasks do not involve any stimuli, but require participants to tap a regular beat at any rate they find comfortable. This provides information both about the rate that people are likely to tap at and the degree of variability in this rate. Tapping rate is thought to happen at a particular ‘personal tempo’ which remains fairly steady but can vary according to certain physiological conditions such as temperature (Fraisse, 1963). A comfortable tapping rate for most people is between 200ms and 900ms (Handel, 1989) although can vary further than this. Beyond 1800ms it becomes hard for people to link two rhythmic events together so tapping rates are unlikely to exceed this distance, while lower tapping limits are generally set by motor capacities (Repp, 2005). Typical variability is about 3-6% of the average tapping rate (Madison, 2001). While it has been shown that age can have an effect on spontaneous tapping rate and variability (Vanneste, Pouthas, and Wearden, 2001), this effect does not seem to hold in adults between the ages of 21 and 75 (e.g. Greene and Williams, 1993) when mean tapping rates remain constant.

### **1.3.3 Synchronisation-continuation tasks**

Another variation on the tapping task is the synchronization-continuation paradigm, introduced by Stephens in 1886, in which people are asked to synchronise to auditory stimuli which then stop, and subjects are required to continue tapping at the same rate as they were during the auditory stimulus. This measures how successfully people are able to maintain entrainment once it has been established, and how this might vary when they are exposed to different kinds of auditory stimulus in the synchronisation phase. This original experiment showed that short intervals are likely to be shortened further while long intervals are lengthened without auditory pacing.

Imaging of these two phases of a tapping task has suggested there is more activation of bilateral supplementary motor areas and basal ganglia during continuation as opposed to synchronisation (Lewis, Wing, Pope, Praastra and Miall, 2004). However, as this study used participants who had overlearned the tapping task it is possible that cerebellar networks would generally be more involved when people were unfamiliar with the task (e.g. Penhume and Doyon, 2002 show that the cerebellum is only active during the learning phase of a tapping task and activity decreases in this area afterwards).

Tapping tasks have generally been concerned with looking at different neural systems involved in SMS, and error correction systems. However, in the current study it was important to identify if any effect of pitch could be identified (due to the implications from previous studies with amusics about pitch interference). It was also generally supposed that people experiencing selective rhythm impairments might only be

noticeably different than controls when required to entrain to complex rhythm conditions.

The current study therefore required a set of tests to dissociate good and bad rhythm skills effectively, and also check if changes in pitch could have any effect. A tapping test has been used before to investigate how amusic performs when synchronising to music (Dalla Bella and Peretz, 2003) and concluded that they were worse than controls. However, this was not done with people with selective rhythm impairments, and also required participants to tap along to pieces of music, which involves a complex combination of rhythm and pitch changes, rather than varying these two elements independently.

## 1.4 Current Study

The set of rhythm production tests developed for this study look at a number of different possible factors involved in the accuracy of the participants. However, the requirement is always just to tap a regular beat along to the rhythms heard – requiring participants to ‘find the beat’ of the stimulus when rhythms are complex rather than identically replicating rhythms that are presented. 12 different trials use different rhythms, tempos and variations in pitch to dissociate any effects that these changes might cause for both control and dysrhythmic subjects. Both synchronization and continuation paradigms are used for the set of 12 trials, and spontaneous tapping rates are also measured before the collection of any other data. The spontaneous and synchronization trials both collect 40 taps from the participants, while the synchronization task only collected 15 taps.

The rhythms used were designed by Manon Grube and were developed for a set of perceptual tests (in press). However, as they very effectively dissociate different kinds of rhythm skills they were deemed to be a good set of rhythms to use in this production test. Grube describes two variables in the way that short rhythms can be designed - open vs. compact and strong vs. weak (from Povel and Essens, 1985). Open and compact rhythms were not varied in the current study design as they are important in marking the end of a musical passage. In the current study the same rhythm repeats for the whole period of auditory stimulation so it was thought that the end of a passage would not be a meaningful distinction in this way.

‘Strong’ and ‘weak’ rhythms *were* used in the task. Strongly metrical rhythms feature accent tones on all four downbeat locations for a beat of 4 (i.e. units 1, 5, 9, 13 of 16) while weakly metrical rhythms have two accented downbeats and two silent downbeat locations. Both sets of rhythms have a large number of silent beats on units that would feature in a metrical beat of 2 or 3, so that a beat of 4 was most likely to be assumed. The important difference between these two sets of rhythms is the sense of metre that they induce. While strong rhythms have a very obvious sense of metre, this is harder to identify in weak rhythms. Grube developed sequences of both of these that have exactly the same number of accented beats, the same pattern of intervals and beats, and the same overall metre, to control for any other influences on complexity of rhythm.

Rhythms used in this task are demonstrated graphically here:

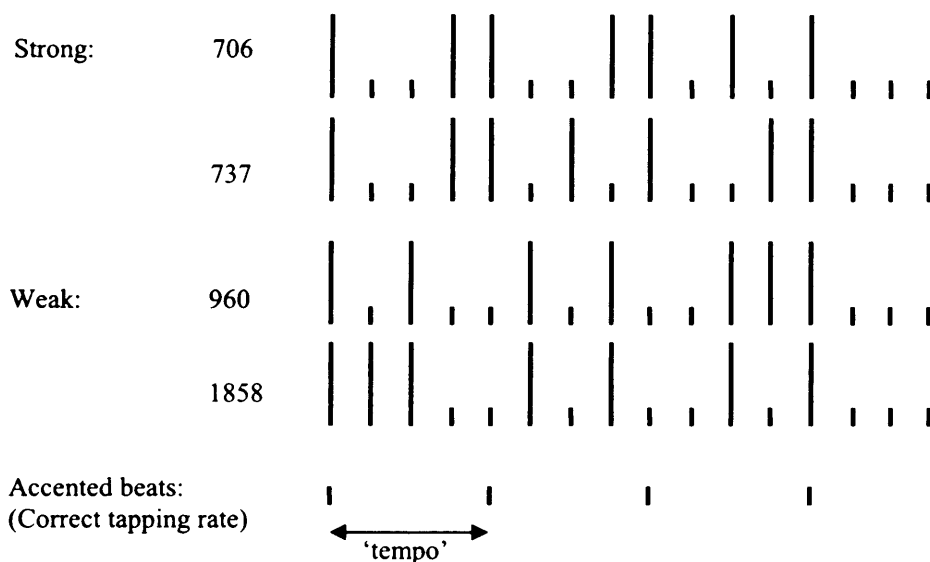

Figure 5. Graphical representation of rhythms used in this study. Long lines indicate auditory tones while short lines are silent. ‘Accented beats’ indicates the four beats that represent the metre of the sequence and are where subjects would be expected to tap if they can determine the metre correctly. Sequences were numbered by Grube during their formulation. Adapted from Figure 1 p. 23 in Grube (in press)

‘Tempo’ will be used in this paper to describe the correct tapping rate in milliseconds. In isochronous conditions this is simply the time between each tone presented (as subjects should synchronise exactly with this). In strong rhythm conditions it is the distance between beats 1 and 5, 5 and 9, 9 and 13 and 13 and 1. In weak conditions the tempo is not marked out with tones on every accented beat.

Tempi were varied between 600ms and 700ms - both of these have been deemed to be comfortable tapping rates for people and there was no difference expected between these two states. The variation in tempo was introduced so that people did not simply become entrained to the first set of isochronous trials and continue tapping at this rate throughout the trials.

Random pitch variation was another variable - this was developed to parallel earlier research into perceptual skills of amusics. It has been suggested that when amusics suffer from both rhythm and pitch problems it is the pitch problem that is primary and they generally have no perceptual problem when there is no variation in pitch. The current study therefore sought to identify whether dysrhythmic people also experience further distraction given pitch variation or not. Random pitch variation was generated online during the task and notes could take any semitone value within a two octave scale.

Trial arrangement:

<b>Trial Number</b>	<b>Rhythm</b>	<b>Intertap Interval</b>	<b>onset</b>	<b>Random pitch?</b>
1	Isochronous	600		N
2	Isochronous	700		N
3	Isochronous	600		Y
4	Isochronous	700		Y
5	Strong	600		N
6	Strong	700		N
7	Strong	600		Y
8	Strong	700		Y
9	Weak	600		N
10	Weak	700		N
11	Weak	600		Y
12	Weak	700		Y

Figure 6. Sequence of conditions in synchronization and continuation tasks.

Trials were arranged using MAX/MSP - a computer program used for designing music. It is capable of millisecond timing accuracy and has been used in previous studies of this kind (e.g Repp, 2001). The program measured the time in milliseconds between each tap made by the participant (intertap interval or ITI) and the period between when the participant was supposed to tap and when they did (asynchrony). A screen print of the patch designed and user interfaces for synchronization and continuation tasks can be found in at appendix 1.

Each trial had 8 initial beats during which the subject could hear the stimulus and tap along, but information from their tapping was not recorded at this point. A timer bar on the screen would indicate this practice period. In the continuation task the bar would indicate when the auditory stimulus was going to stop. Preliminary testing suggested that following the isochronous condition, in which subjects were exactly replicating the beat they were hearing, they were likely to continue this exact



replication for the first 'strong' rhythm. The requirement in this condition is actually to continue tapping a regular beat along to the rhythm, using the same motor output as in the previous task. It was therefore stressed in the instructions that all the trials would simply require the subject to tap a regular beat, and a message on the computer screen lit up at trial 5 to remind the subject that they were no longer required to exactly replicate the stimulus, but should tap a regular beat in time to it.

Complete sequence of testing events:

1. Spontaneous tapping task (40 taps)
2. Synchronisation task (12 trials of 40 taps each)
3. Continuation (12 trials of 15 taps each)

## **2. Methods**

The current study used the Montreal Battery of Evaluation of Amusia as a test of music perception and uses the tapping paradigm described above to test musical production skills. As the MBEA already has a set of normal data there is not a control group for this part, but subjects will be compared with normal data from Peretz et al (2003). As the second study was developed by the author of this paper it was administered to a set of 38 people with normal musical perception skills, in order to determine what a normal response might look like.

Participants were recruited from a database of people who had done a shortened online version of the MBEA (only including the scale and rhythm parts of the test). ‘Dysrhythmics’ were defined as people who had scored below the correct cut-off (of 23 correct answers) in the rhythm test but above the cut-off (23 correct answers) in the pitch test. Control subjects had to score above cut-off in both parts, and had to have completed the online tests more than once. Both sets of participants were re-tested in person in a soundproof room on the first four tests of the MBEA and this had to confirm their online scores before they could move onto the tapping experiments.

The control group consisted of 38 people (18M, 20F; age range 19-61, mean=38.92). Musical experience was not controlled for but participants came from a variety of musical backgrounds, again intended to represent a normal population. The National Adult Reading Test and digit span tests were administered to all participants to control for any differences in intelligence or short term memory. Subjects were all

paid at a rate of £7.50 per hour and were reimbursed for travel costs.

Subjects were split into two groups – group A experienced the trials as listed above while group B started with a 700ms tempo trial and alternated between tempi. This was to ensure that any interaction between the different rhythms and tempi would balance out across groups.

The MBEA was administered on a DELL Latitude X1 using Sennheiser HD 265-1 headphones, and an Edirol UA-3FX external soundcard using MATLAB 7. The tapping tests were administered using a DELL XPS M1530, Sennheiser HD 265-1 headphones and an Alesis io2 external soundcard using Max/MSP 4.5. Subjects were told to tap using their preferred hand and taps were recorded using the computer keyboard.

## **3 Results**

### **3.1 MBEA**

3 participants scored badly on the rhythm part of the MBEA whilst scoring well on the pitch part (Subjects 39, 40 and 41). This is a small number of people to make widescale inferences about how this group might generally behave. However, given that previous research suggested there was no-one who would score in this way it is interesting to get some insight into these few participants.

It has been suggested by Peretz et al. (2003) that pitch scores correlate highly and can be amalgamated to give an overall percentage correct for this part of the test. Scores for these subjects are given here. As all subjects were tested on four parts of the MBEA in person their scores are given as appendix 2 here, but comparison for dysrhythmics is done with the normal data from Peretz et al. (2003) introduced earlier in the paper.

SubjectNo.	Scale	Contour	Interval	Rhythm	% Correct Pitch (amalgamated)	% Correct Rhythm
39	29	25	24	22	86.67	73.34
40	28	30	27	21	94.4	70
41	29	26	27	20	82	67.67

Figure 7. Dysrhythmics scores on MBEA

When compared with normal data from Peretz et al. (2003), dysrhythmics were scoring 2 standard deviations below the mean on rhythm tests but above this cut-off score in all pitch tests.

## **3.2 Tapping tasks**

As the task designed for this experiment has not been used before, analysis of the control data is important in itself, and data for control subjects in all the different tests will be explored here before looking at how the dysrhythmic subjects fit into these trends. Data was analysed using Microsoft Excel 2007 and SPSS v. 14.

### **3.2.1 Spontaneous tapping task**

For the spontaneous tapping data (in which participants were asked to tap a regular beat with no auditory stimulus), the first 10 taps were first removed as it is assumed that it takes a short period for participants to start tapping at a regular rate. Mean tapping rates for the trial for each participant were used to identify any population trends. Standard deviation of the trial was used as a measure of variance in each participant, and this was divided by their mean for the trial to give a percentage variance value. The mean tapping rate showed a similar trend to previous studies – ranging from 482.1ms-1196.0ms with a mean of 721.1ms and standard deviation of 171.9ms. Data was normal after log transformation so can be compared with data for dysrhythmics in the section that follows.

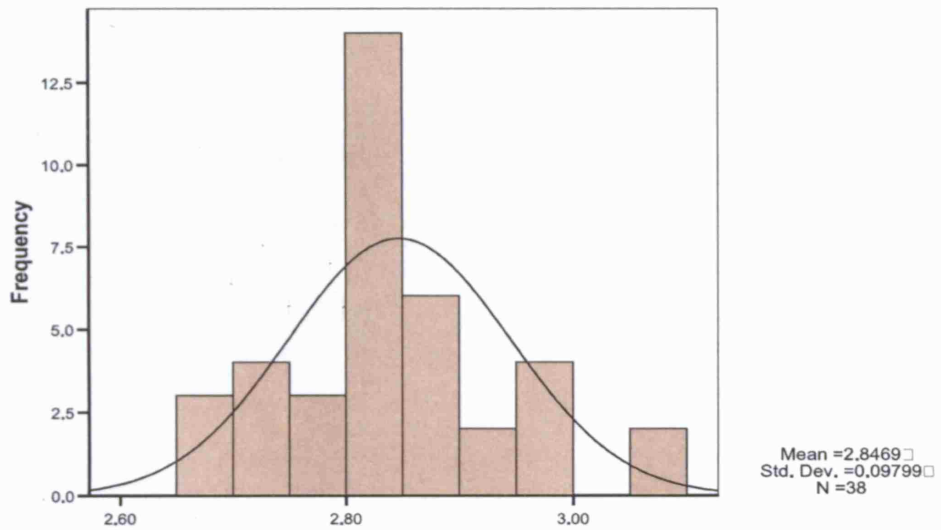

Figure 8. A histogram showing mean spontaneous tapping rates following log transformation

Deviation in tapping rate was also similar to that found in previous studies, ranging from 2.21%-6.73% of the trial mean (Mean= 4.12, S.D.=1.10, N=38). Data was normal for this measure so can be compared with data for dysrhythmics in the section that follows

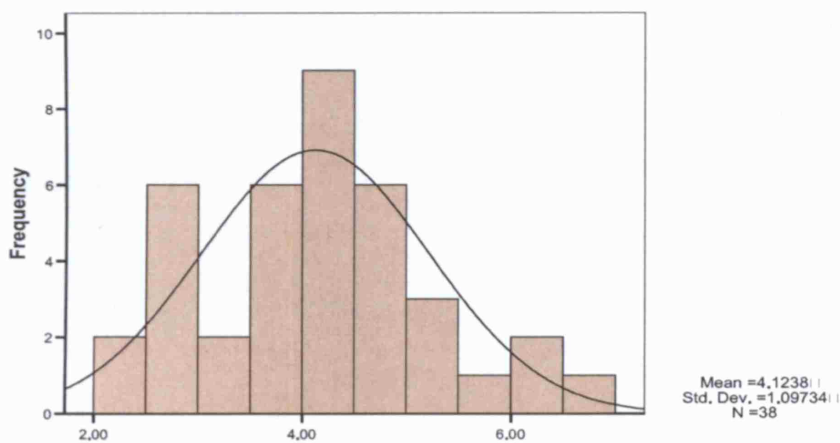

Figure 9. A histogram showing percentage deviation in spontaneous tapping rate

### 3.2.2 Continuation task

In this task, a statistic for drift was calculated by looking at the intertap interval (ITI). This is the length of time between each tap that the subject made. As the correct tapping rate was different in different trials a percentage error rate for interval was calculated using:

$$\frac{(ITI - \text{tempo}) \times 100}{\text{tempo}}$$

This error value was then averaged over the first 4 taps of the continuation task (the first four taps following the end of auditory stimuli) and averaged over the last 4 taps of the continuation task. This gave two mean percentage error values for each participant, one for the start of continuation task and one for the end. The mean percentage error value at the start of the task was subtracted from that at the end of the task to give an overall drift rating in the tapping rate with a sign indicating if they sped up (positive values) or slowed down (negative values) over the task.

Participants 20, 28 and 35 were excluded from analysis in this task due to missing data.

Data for this task was analysed in baseline conditions (i.e. when subjects are tapping along to isochronous rhythms with no interference of pitch) because of the large amounts of data involved in comparing different conditions. Drift values were calculated for both 600ms tempo and 700ms tempo conditions and normal data was found in both conditions. This normal data can again be compared with dysrhythmic

participants in the following analysis.

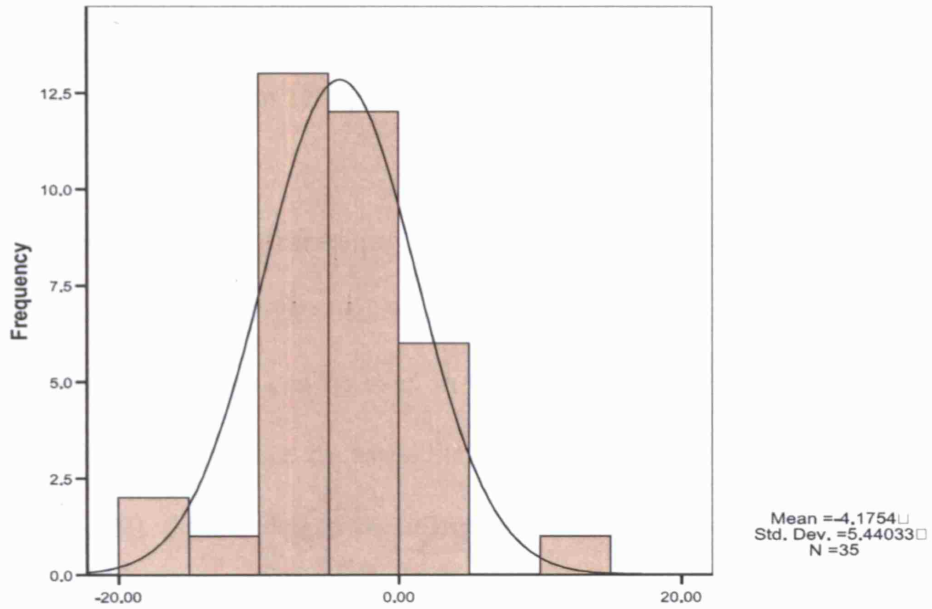

Figure 10. A histogram showing drift from original tapping rate (as a percentage error score from correct tapping rate) following a continuation task in controls at a tempo of 600ms.

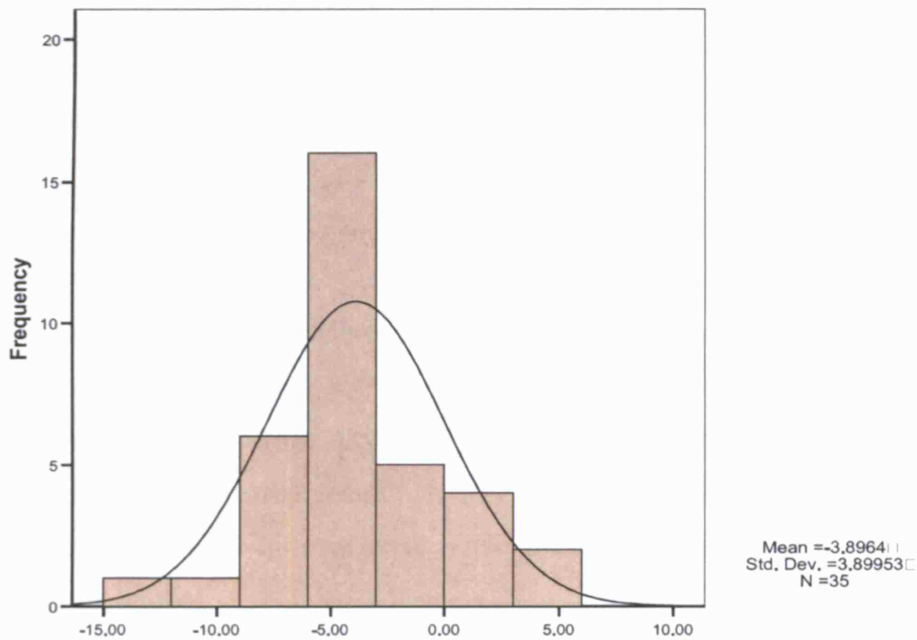

Figure 11. A histogram showing drift from original tapping rate (as a percentage error score from correct tapping rate) following a continuation task in controls at a tempo of 700ms.



### 3.2.3 Synchronisation task

A large amount of data was obtained for the synchronization task, as participants provided 40 taps per trial in 12 trials.

In the control data it is interesting to see what effect the different rhythms and introduction of random pitches had on accuracy and variance in tapping. A number of different accuracy ratings can be used in this kind of study. Asynchrony is an error value per tap (i.e. how late or early the participant was for tapping in time with auditory stimuli). Again, due to the different tempi used in different trials this was transformed into a percentage error value by dividing by the tempo of the trial. Percentage interval error was also calculated as described above (in the section on continuation). Absolute values for these errors were used to obtain a mean error value for each trial. The standard deviation of signed error values were calculated for each trial to indicate variance in error per subject per trial. This resulted in four final measures for analysis:

1. Mean Percentage Asynchrony – the average asynchrony as a percentage of correct tempo.
2. Variance of Percentage Asynchrony – the standard deviation in asynchrony as a percentage of correct tempo.
3. Mean Percentage interval error – the mean error in ITI as a percentage of correct tempo.
4. Variance of percentage interval error – the standard deviation in ITI as a percentage of correct tempo.

Subjects 37, 6 and 3 were excluded from the analysis as they were missing data for

one or more trial. Another problem led to the exclusion of a large amount of data. If the percentage interval error value was over 100% it indicated that the subject had entirely missed one beat of the musical sequence, and had synchronized with the next one instead.

In some trials participants showed very high mean values for ITI – indicating that they were tapping at the incorrect tempo throughout the trial. This was most noticeable in the weak rhythms, which were meant to be very hard to synchronize with correctly. Participants 11, 15, 20, 24 and 34 were excluded from analysis because the value for outliers in one of the weak trials was more than 100% or less than -100%. One trial demonstrating tapping rates of these participants in weak rhythm condition is included in appendix 3. This criteria would also exclude all of the dysrhythmic subjects due to data in the strong rhythm trials and this problem will be addressed later in the paper.

ITI and asynchrony data values were excluded if the ITI was greater than 75% as this was deemed to be indicative that the subject was synchronizing to the next beat instead of the previous one. This exclusion criterion led to the removal of 51 further pieces of data (less than 0.5% of the data).

These graphs show trial averages and deviations following these exclusion criteria:

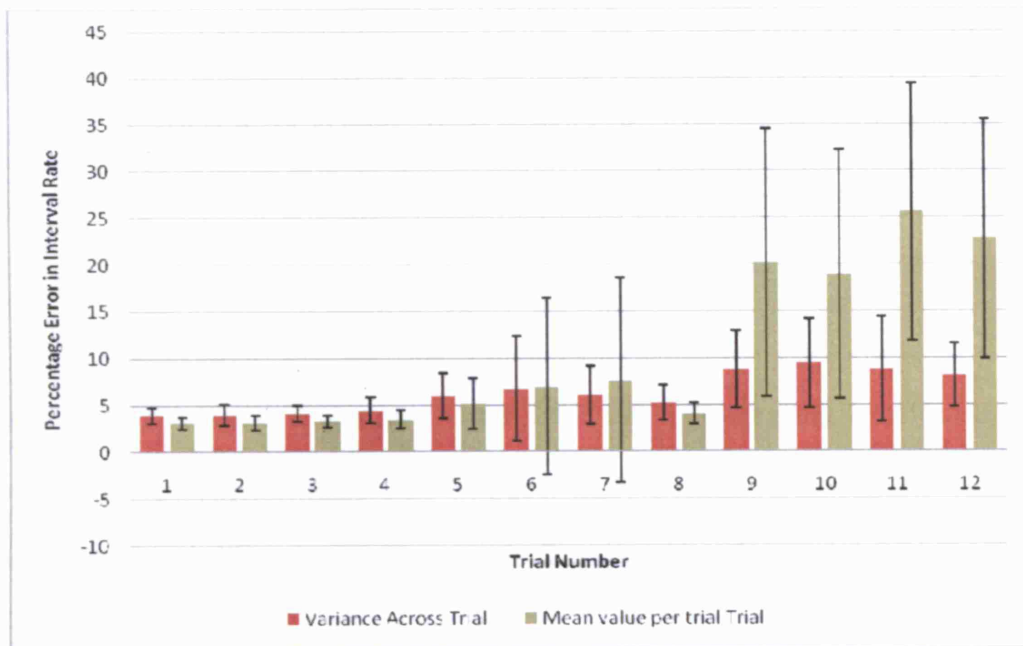

Figure 12. A graph showing average percentage interval error rate per trial, and deviation from this rate. Error bars indicate standard deviation.

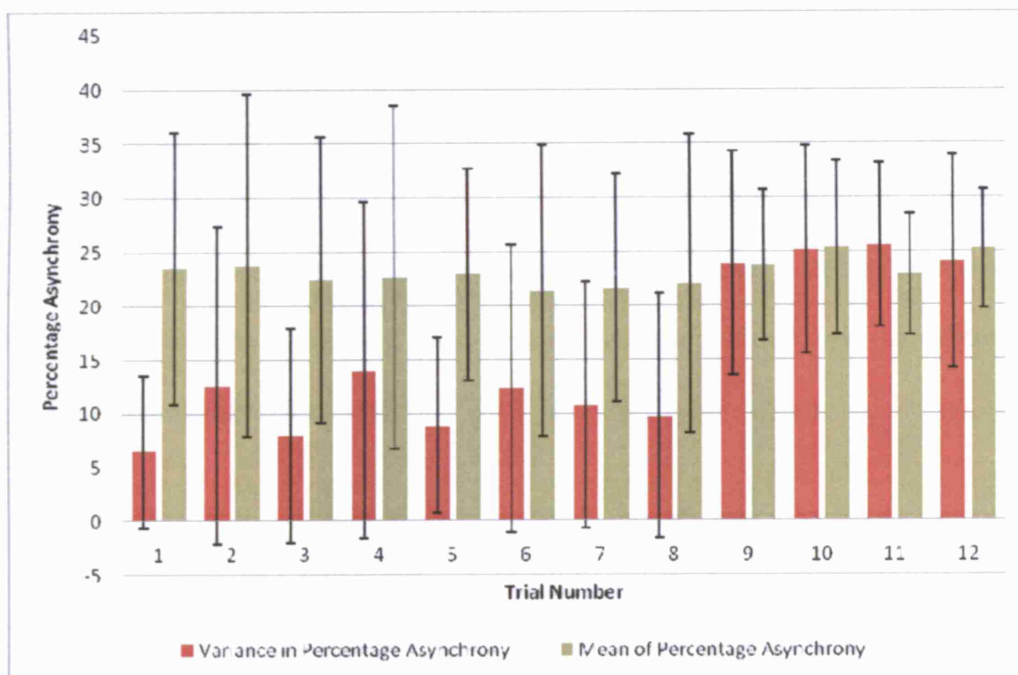

Figure 13. A graph showing average percentage asynchrony per trial, and deviation in this rate. Error bars indicate standard deviation.

Error bars in these graphs show standard deviation and demonstrate that even with exclusion criteria there were very high deviation rates that made data hard to analyse statistically. Participants 16 and 29 and 35 were excluded from data analysis because more than 3 of their trials had outlying mean values compared with other participants, and would skew the data too far to do statistical analysis.

Even with this stringent exclusion criteria data, and following log transformation, values for the mean percentage asynchrony and variance in percentage asynchrony were highly abnormal in almost all the trials. This data was therefore not analysed at this time.

Following log transformation, variance in percentage interval error was normal across all 600ms interval trials and a 3 x 2 repeated measures ANOVA was performed for the three rhythm conditions and random pitch variation. A main effect of rhythm was shown,  $F(2, 52) = 67.954$ ,  $p < 0.001$ ,  $r = .71$  with no effect of random pitch variation ( $p = .792$ ) and no interaction between the conditions ( $p = .364$ ). Post-hoc t-tests with Bonferonni corrections confirmed that every rhythm condition was significantly different from the others ( $p < 0.001$ ).

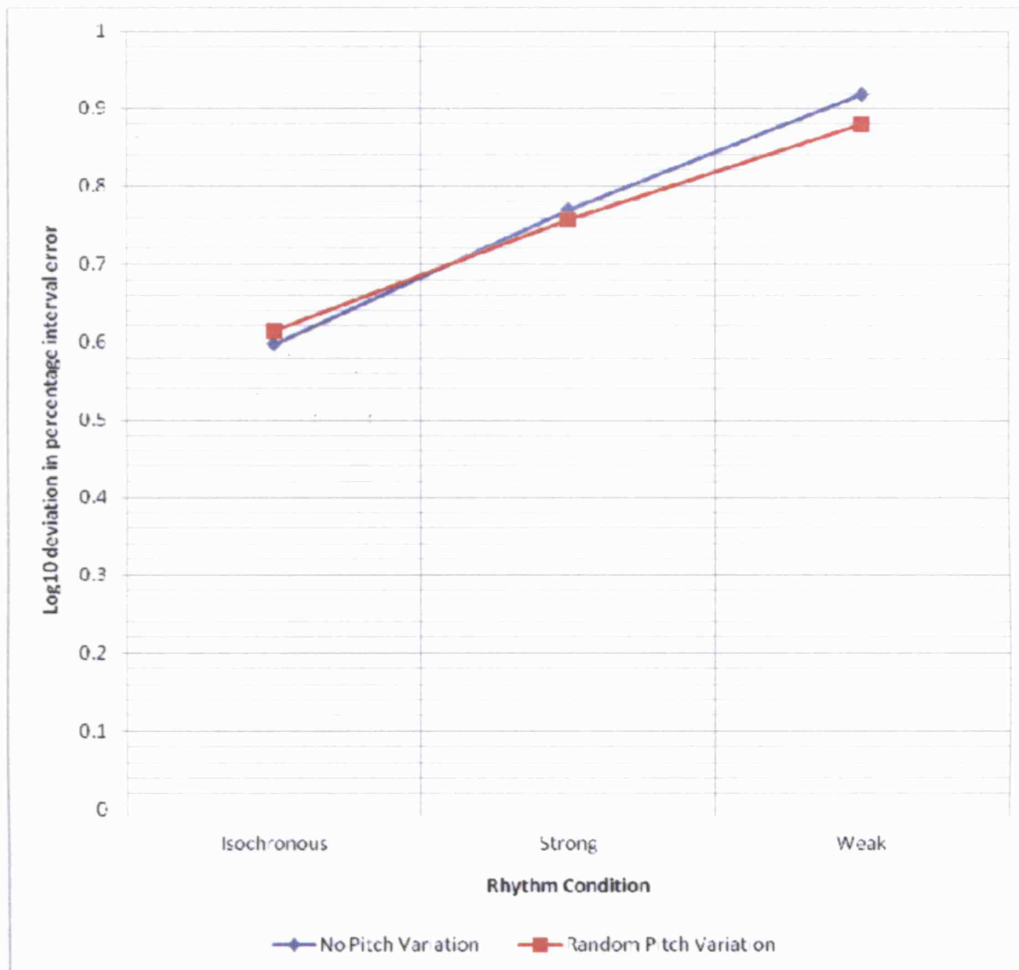

Figure 14. A graph showing change in deviation in percentage interval error across different rhythm conditions with and without random pitch variation (at 600ms).

Following log transformation mean of percentage interval error was normal in isochronous and strong rhythm conditions so these were compared using a 2 x 2 repeated measures ANOVA for rhythm conditions and random pitch variation. This also demonstrated a main effect of rhythm  $F(1, 26) = 35.442, p < 0.001, r = .56$  with no effect of pitch variation  $p = .364$ .

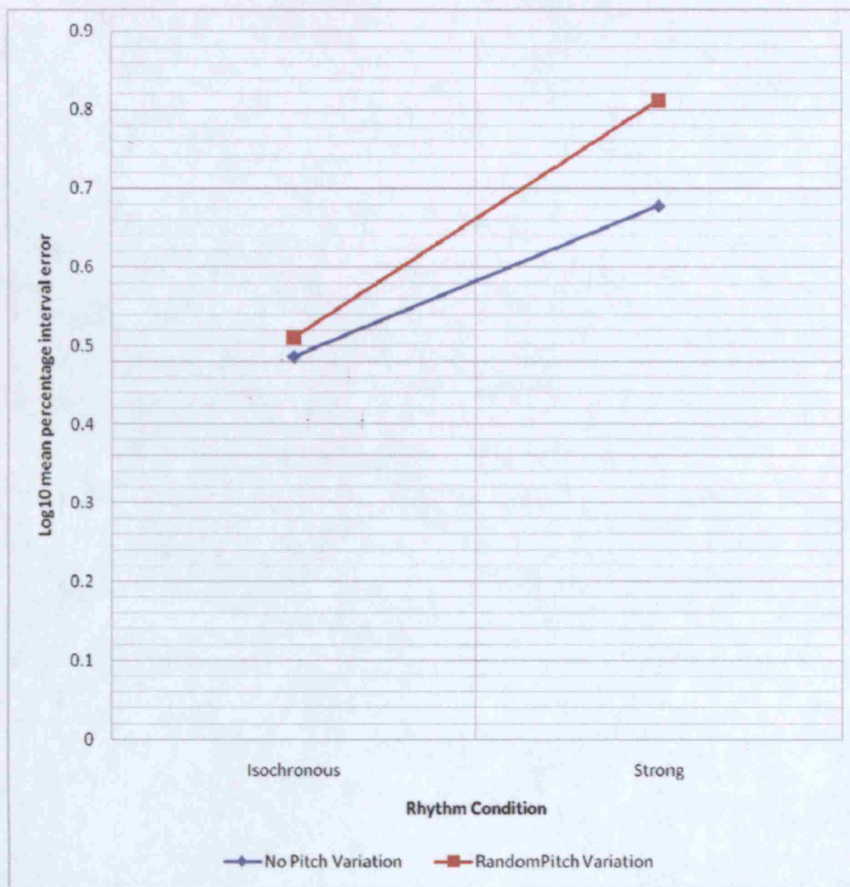

Figure 13. A graph to show change in mean percentage interval error in different rhythm conditions with and without random pitch variations (at 600ms)

As the exclusion criteria for control subjects would have involved excluding dysrhythmic subjects there can be no statistical analysis of this data. However, there will be a set of descriptive statistics later to demonstrate some possible group effects.

### 3.2.4 Dysrhythmic comparison

#### 3.2.4.1 Spontaneous Tapping

Dysrhythmic data will be compared with normal distributions for spontaneous tapping rate and continuation data.

Spontaneous tapping rates and variations in tapping rate for dysrhythmics are given below along with the group averages for controls. Log transformed values for mean have also been calculated as these were used to obtain normal data in controls for comparison:

SubjectNo.	Mean Spontaneous Tapping Rate	Variation in Spontaneous Tapping Rate	Log transformed mean
39	916.3	6.30	2.96
40	714.8	3.95	2.85
41	600.3	3.63	2.78
Control Average (S.D.)	721.1 (171.9)	4.12 (1.10)	2.84 (0.098)

Figure 14. Mean, variation and log10mean of spontaneous tapping rates in dysrhythmics and controls.

As data from the control sample was not completely normal and taken from a fairly small sample, comparisons were made using 'singlims.exe', a program developed by Crawford and Garthwaite (2002) to compare single subjects with control groups – this will give slightly more conservative p-values than z-scores would. Comparisons for mean tapping rate were not significant in any subject. Values for variation in tapping rate neared significance for subject 39 ( $t = 1.959$ , One-tailed probability  $p = 0.029$ ). It

seems appropriate to use a one-tailed test here as we would predict dysrhythmics to be worse than controls in all cases. However, as the other two subjects showed slightly less variance in rate than controls it seems more appropriate to use a conservative value of p and use the two tailed probability (0.058) which is not quite significant.

### 3.2.4.2 Continuation Tapping

Drift rates were calculated in the same way for dysrhythmics as they had been for controls and the values are given below:

Subject	Tempo Drift at 600ms	Tempo Drift at 700ms
39	-1.00	-4.04
40	-0.04	-5.47
41	-2.71	2.29
Control Average (S.D.)	-4.18 (5.44)	-3.90 (3.90)

Figure 15. A table showing drift rates as a percentage interval error of correct tapping rate in dysrhythmics and controls, at 600ms and 700ms.

Dysrhythmics did not vary significantly from controls in these measures.

### 3.2.4.3 Synchronization Tapping

As has been explained previously the comparison made of control data in the synchronization task involved extensive data exclusion and therefore cannot be compared with dysrhythmics anymore. However, an important difference was noted in the performance of dysrhythmics and controls over different rhythm conditions, the number of beats missed during attempts to synchronize.

ITI values were therefore added together to work out the absolute time that had elapsed since the beginning of the trial, and these were compared with how much time



should have elapsed if the subject were tapping along to every beat correctly. If these two values became more than the correct tempo apart it was considered to indicate a missing beat.

This table shows the number of beats missed (out of 40) per dysrhythmic subject with mean and standard deviation values for the controls. Subjects 3 and 37 were excluded due to missing data but all other subjects are included:

Subject Number	Trial 1	Trial 2	Trial 3	Trial 4	Trial 5	Trial 6	Trial 7	Trial 8	Trial 9	Trial 10	Trial 11	Trial 12
39	0	0	9	0	23	11	19	19	*	17	13	17
40	0	0	0	0	19	19	19	19	*	10	9	9
41	1	0	0	7	0	1	19	0	11	12	6	12
Control Mean (S.D.)	0.05 (0.23)	0.29 (1.63)	0.05 (0.23)	0.11 (0.51)	0.87 (2.51)	1.16 (3.05)	0.87 (2.59)	0.26 (1.46)	6.32 (5.50)	5.97 (6.14)	6.76 (4.22)	6.47 (4.75)

Figure 16. A table showing number of beats missed in controls and dysrhythmics. Highlighted cells indicate that subjects were probably synchronizing at half the correct tempo. \* indicates missing data.

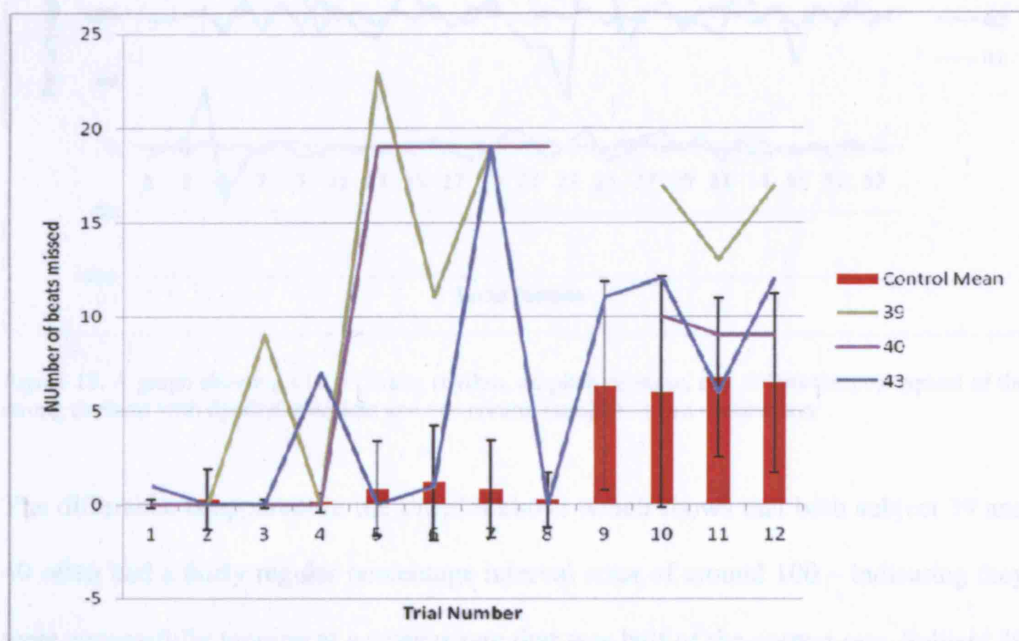

Figure 17. A graph showing number of beats missed by dysrhythmic subjects in all trials. Red bars show mean data for control subjects and error bars display their standard deviation. Trials 1-4 are isochronous, 5-8 are strong rhythms, 9-12 are weak rhythms.

These values cannot be compared statistically as the control group do not form a normal distribution – due to a large skew towards 40 correct synchronizations in the isochronous and strong rhythm conditions (trials 1-8) meaning it is not possible for single subject comparisons. However, it can be seen that subjects 39 and 40 were missing about half the beats in a number of the strong rhythm trials (5-8) which is indicative of the fact that they were generally synchronizing with half of the beats, rather than every single one.

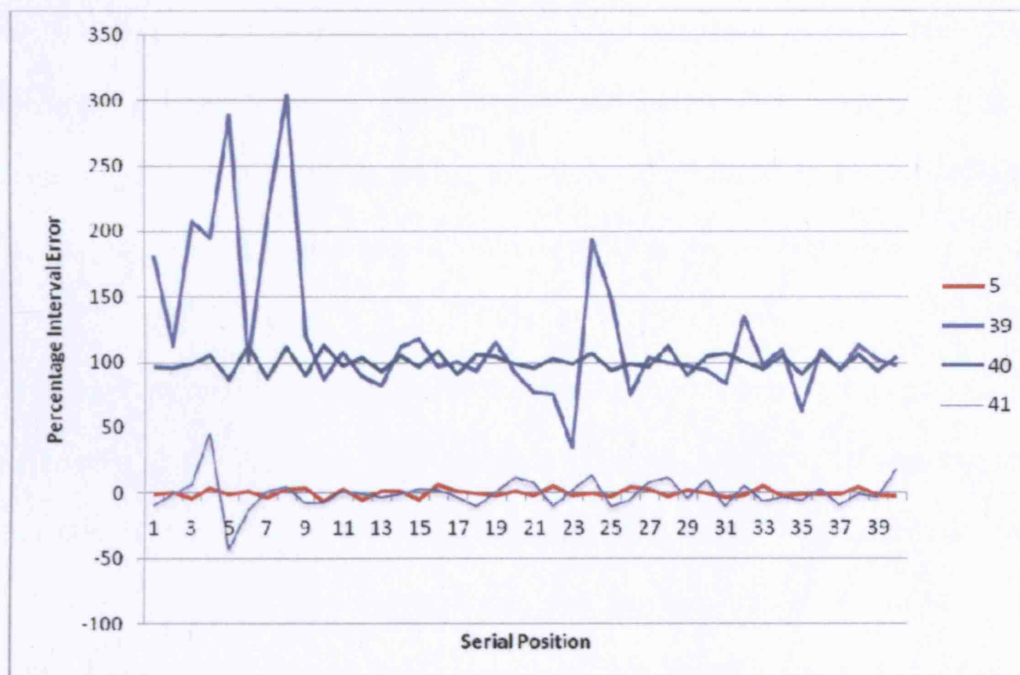

Figure 18. A graph showing trial 5 (strong rhythm, no pitch changes, and 600ms tempo), typical of the strong rhythms with dysrhythmic data and one control (subject 5) as a comparison

The difference is apparent in the lineplot above which shows that both subject 39 and 40 often had a fairly regular percentage interval error of around 100 – indicating they were successfully tapping at a regular rate that was half of the correct one. Subject 39 also shows patterns of trying to entrain with other higher level metric rates (e.g.

tapping at a percentage interval error of 300, indicating she is tapping at a third of the correct speed). Subject 41 does not show this pattern but did synchronise with half the beats in trial 4 (an isochronous condition with random pitch variation) and trial 7 (a strong rhythm condition with random pitch variation). In the control group, only three other participants missed more than 4 beats in isochronous or strong rhythm condition – subject 1 missed 8 beats in trial 6, subject 31 missed 12 beats in trials 6 and 7 and subject 34 missed 11 and 12 beats in trials 5 and 6 respectively.

## **4. Discussion**

### **4.1 MBEA**

The use of the Montreal Battery for the Evaluation of Amusia demonstrated the possibility for subjects to show poor rhythm perception with preserved pitch production. This finding is in keeping with the aims of the project, and reflects the aims of other current research in the field (e.g. Iversen and Patel, in press). It also confirms that congenital amusia conforms to similar patterns as acquired cases. This dissociation provides further evidence for different brain regions being involved in different aspects of music perception. However, it remains to be shown what differences might actually exist between control subjects and dysrhythmics.

As was suggested in the introduction, rhythm processing has been associated with the left PAC. As this is thought to be involved in rapid processing of phonological information it seems possible that dysrhythmics may suffer from some language perception impairments. However, it seems that multiple regions in the brain are capable of some degree of temporal processing, and impairments in dysrhythmics could stem from another source such as the cerebellum, or even areas of the peripheral nervous system.

More investigation into processing deficits in dysrhythmics is necessary. A comparison needs to be made between the effect that addition of pitch changes makes to their ability to do purely perceptual tasks in order to determine the relationship

between this kind of disorder and conventionally described amusia, which is a pitch processing deficit.

Subjects who suffered from dysrhythmia showed some level of insight into the problem when they were being tested on the MBEA, and the subjects tested were able to report that they had a poor sense of rhythm compared with other people. More than one dysrhythmic subject also commented on how much harder the MBEA seemed when they were hearing rhythm changes rather than pitch changes (subjects were ignorant of the changes in different trials until after the test), saying that suddenly the trials sounded 'the same, but different'. The changes in musical structure that had seemed more clear cut in previous trials were now harder to identify and define.

Following the results of the test one subject commented that she had always thought she was tone deaf, but at the same time was aware that she could tell the difference between different pitches of notes. Having never previously identified that this was due to a pure rhythm deficit she had assumed it was a general lack of musical ability. The use of the MBEA to clarify where the problem lay was therefore beneficial to this subject, and her experience suggested that the test results had some ecological validity.

## **4.2 Tapping Tasks**

### **4.2.1 Spontaneous tapping rate**

No difference in spontaneous tapping rate was found between control subjects and dysrhythmics. This was expected, as speed of tapping does not relate to any specific perceptual or rhythmic problems. However, there was also no significant difference in variability in tapping rate. If we assume that dysrhythmics suffer from a general impairment in all rhythm tasks it is possible that they would have trouble with the coordination required to maintain a steady beat, or even that they would not be able to recognize what a steady beat was.

### **4.2.2 Continuation task**

The similarity between dysrhythmics and controls in this task again suggest that once dysrhythmics have become entrained to a rhythm they are just as capable as controls at maintaining a constant tapping rate. Combined with the spontaneous tapping rate finding this has several implications.

The general capacity to tap well in the spontaneous and continuation tasks suggests that the internal timekeeping module (as postulated by Wing and Kristofferson, 1973) is intact in dysrhythmics. In order to successfully keep time in the continuation task it is necessary to synchronise this internal timekeeping device to an external stimulus and maintain this rate.

Dysrhythmics also do not seem to be affected by any major motor problems. It has been shown previously that motor areas of the brain can be activated during rhythm and beat perception tasks (Grahn and Brett, 2007) which implies that there is interaction between these two functions. Despite having poor rhythm perception, dysrhythmics were still able to produce a regular beat when tapping, even in the absence of auditory stimuli. If there is a common timekeeping device used for both production and perception skills it seems unlikely that this is affected in dysrhythmics.

A previous study looked at the ability of cerebellar patients to perceive perturbations in an auditory stimuli whilst tapping along to it (Molinari et al, 2007). Despite being unable to report the perturbation in rhythm, subjects *were* able to synchronise with the change. This dissociation between consciously perceived rhythms and automatic entrainment skills is in keeping with the current finding about dysrhythmics. However, it cannot be inferred that dysrhythmics have any specific cerebellar dysfunction as this would probably be evident in other motor skill areas. It has also been shown previously that cerebellar regions are activated selectively during continuation tasks (e.g. Jäncke, R., Loose, R., Lutz, K., Specht, K., Shah, N. J., 2000) and as dysrhythmics seem to perform normally on these tasks, it seems unlikely that this is where rhythm impairments stem from.

Further research could involve similar perturbation studies with dysrhythmics in order to ascertain if they show exactly the same pattern. If automatic phase resetting is observed then it would be interesting to discover if they have conscious awareness of

these perturbations.

It is possible that the short period (of 15 taps) used in this experiment meant that there was not enough drift in tapping rate to see a difference between the two groups. This could be improved with a longer data collection period.

### **4.2.3 Synchronisation task**

Data that was analysed for controls suggested that Grube's rhythms were successful in becoming progressively harder to entrain to. Variability in tapping rate became greater between isochronous and strong rhythms, and between strong and weak rhythms. The difference between isochronous and strong sequences suggests that direct replication of beats was easier than metre extraction.

The difference between strong and weak sequences implies that the ability to correctly extract metre was dependent on rhythmic structure rather than metric accent as described by Drake and Palmer, 1993). If metric accent (based on absolute times) were used to detect rhythm patterns then it should be possible to identify metre similarly in the two conditions as they both had the same period. However, it seems that the grouping of accented beats is what made the strong rhythms easier to entrain to in control subjects.

It was also shown that random pitch variations had no impact on the ability for control subjects to synchronise with rhythms. This shows that the level of interference between pitch processing and rhythm processing is quite low in controls. It will be



interesting in future to successfully compare this with dysrhythmics to see if they show any interference when pitch is introduced into a rhythmic sequence, with a prediction that they should not. However, the tests could also be run on a conventional amusic population. This should show a similar pattern to that observed in perceptual tasks (e.g. Foxton et al, 2006), with good rhythm skills until the introduction of pitch elements to the musical sequence.

While it has previously been shown that random pitch sequences show the same activation in the brain as musically relevant ones (Griffiths et al, 2003) it would be interesting to try running the set of tapping tasks using more musical sequences than the randomly generated pitch patterns that were used in this test. However, it is still important to start with a sequence that initially only has rhythm elements, and then introduces pitch at a later stage. A recent set of tapping tasks designed to identify dysrhythmics (Iversen and Patel, in press) goes straight from isochronous tapping to tapping along to popular pieces of music. This introduction of a number of elements (pitch, rhythm, 'finding a beat' and familiarity) all at the same time negates any findings about how much worse dysrhythmics might perform in the trial.

Comparison of dysrhythmics and controls was mostly unsuccessful due to large variation in the control data. However, looking at data for missing beats and ITI values in some conditions did suggest that dysrhythmics were likely to miss half of the correct beats when asked to synchronize with the strong rhythms. This could be due to motor problems but as this did not occur often in the isochronous condition, and spontaneous and continuation data suggest they did not have any particular motor deficits stopping successful entrainment, it seems likely that these missed beat values

are indicative of a failure to correctly perceive the meter in these rhythms, rather than due to unsuccessful rhythm production skills. It also replicates Dalla Bella and Peretz's finding (2003) with conventionally amusic subjects.

The pattern of missing half the beats for whole trials, and having large numbers of ITI's at double the correct tempo in strong conditions shows that dysrhythmics were not incapable of perceiving metre in the music at all, but simply that they were entraining at a higher hierarchical level of meter. It is often possible in patterns of music to group rhythms together in a number of possible ways, none of which are necessarily incorrect. Taking a strong rhythm as described earlier it is possible to see how two potential groupings can exist, one at half the tempo of the other.

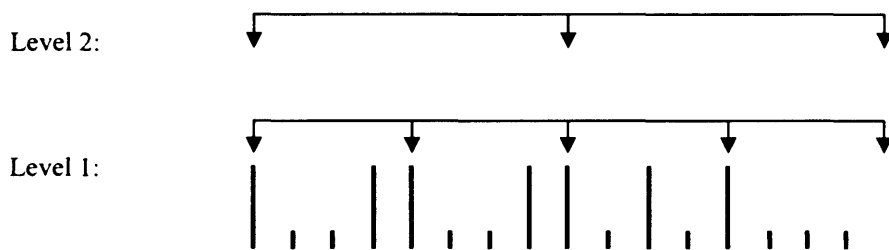

Figure 19. A strong rhythm with two possible ways of grouping the accented beats.

While it is thought that people should generally be quite capable at tapping along in time to music the criteria for this being successful is simply if successive taps coincide with tones in the music, regardless of what hierarchical level this occurs at (Drake and Bertrand, 2001).

It has been shown, however, that age and musical training can have an effect on the

hierarchical level at which a person entrains to music (Drake, Riess Jones and Baruch, 2000). Young children are only able to synchronize with beats at the lowest level and are constrained by mirroring the exact physical properties of music. With increasing age and musical training, subjects in this study seemed to have more freedom to split rhythms in a hierarchical fashion, and entrain to beats at up to four different levels.

This seems to be in contrast with the findings of this paper, in which people with particularly bad rhythm perception are using greater levels of a metrical hierarchy. However, it is possible that dysrhythmic subjects were not freely choosing level of metre but were constrained by the fact that they could not easily recognize the lowest level of metre in the strong rhythms condition. This is an entirely different state from that of children, who are compelled to tap at the fastest possible meter, and is again indicative of the perceptual problems of dysrhythmics.

As dysrhythmics appeared to entrain to a higher level they might have been using a 'metric accent' approach to extracting a sense of rhythm rather than 'rhythmic structure'. It has already been suggested that control participants used the latter strategy to detect metre due to their better performance on strong trials. Dysrhythmics do not seem to be extracting information usefully at low level grouping so it is possible that in fact they are having to rely on more absolute time values in order to determine a sense of metre.

### **4.3 Limitations**

This experiment had some obvious limitations. Firstly, the small sample size for the dysrhythmic group is problematic. However, given that this population has never been identified before it is possible that they are a very small group. The sets of online tests that were used to find participants were widely advertised and were taken by a large number of people. A small number of people showed specific dysrhythmic patterns online. Further to this, several people who had shown this pattern in the online tests did not show the same results when they were tested in person – a problem here being that the online tests ran the pitch test first, followed by the rhythm test, so people were more likely to be distracted by the time they took the second part.

Another possible limitation was the use of a computer keyboard in the tests rather than a more accurate recording mechanism. A common finding in tapping experiments is a negative mean asynchrony i.e. subjects are tapping slightly before the beat they are meant to synchronise to (e.g. Müller, Schmitz, Schnitzler, Freund, Aschersleben and Prinz, 2000; Aschersleben, 2002; Repp, 2005) and this was absent in the current study. This may explain why the data for asynchrony appeared to be fairly randomly distributed in a large number of cases and could not be analysed. If this experiment was repeated taps would ideally be measured on a custom made touch sensitive pad that could measure pressure levels as well as having millisecond timing accuracy.

The necessity for lots of data exclusion is a big weakness in the set of tests, and suggests that there need to be more stringent ways of ensuring that people are tapping

correctly. Previous experiments have used online monitoring of tapping rates in order to ensure that subjects are not missing so many beats that the data becomes hard to analyse (e.g. Semjen et al 2000). However, as the main finding with regards to dysrhythmics in this study was that they seem to tap at a higher metrical hierarchy, online monitoring to stop this might exclude dysrhythmics from participating at all.

The finding that dysrhythmics tap at the wrong metre in complex rhythms is undermined by the fact that other participants occasionally entrained to this higher level of metre for short periods. This is problematic because it suggests that there could have been some level of ambiguity in the task. As participants were simply asked to tap a regular beat in time with the rhythms they heard it is possible to believe that the hierarchical metre at which the dysrhythmics were often tapping was the correct one. However, the use of isochronous trials preceding the first strong rhythm trial should have helped to avoid this problem. As subjects became used to entraining to tempi of 600ms and 700ms it should have seemed natural to continue this into the trials involving complex rhythms. It is possible that the finding in dysrhythmics simply reflects a lack of continued entrainment to the period following each trial, as they were unable to recognize the tempi they had previously tapped along to.

The number of different trials in the experiment led to a very large amount of data for analysis and some of this (particularly in the continuation task) had to be disregarded for the purposes of this paper. In retrospect it might have been better to limit the aims of the tapping tasks to more specific questions that could be answered with less raw data.

The problem of data abnormality meant that it was not possible to use the asynchrony measure at all statistically. This meant that the ITI was used as a measure instead. This could be problematic because these values are inherently dependent on one another. If one ITI is a bit too long it is likely to lead to a slightly shorter ITI in the near future to compensate. Asynchrony is a better value because it does not have this dependence from tap to tap. However, as values for ITI were averaged over trials the dependence does not constitute a problem in calculating statistics. Mean ITI's can provide a good indication if people are unaware of the correct rate at which to tap – which is likely to be true if they are having perceptual problems in extracting metre from a rhythm. As this task involved progressively more complex rhythms it is useful to recognize the problems that are experienced in extracting metre, so ITI's could be a good measure. It also seems that dysrhythmics may have problems extracting metre, so again the ITI measure is a useful one. However, the lack of usable data in the asynchrony measure means it is hard to infer anything about any general difference in accuracy at motor synchronization between controls and dysrhythmics.

The missing beat values that was used to infer different metre extraction in dysrhythmics and controls is also not an ideal measure but was an ad hoc addition given the way that the data appeared. Further experiments could perhaps focus more specifically on the question of whether people with poor rhythm perception skills are likely to synchronise at a different hierarchical level than controls, and could be designed in a way that addresses this question better.

## **4.4 Conclusions**

While there were only a small number of dysrhythmics identified in this study it opens the way for researchers to actively seek out this group for further investigation. It also confirms that congenital patterns of amusia are similar to acquired cases. The tapping task had some flaws as it led to large amounts of unusable data but did establish that controls got worse at detecting metre between strong and weak rhythms in a production test.

In this study dysrhythmics were shown to be capable in spontaneous and continuation tasks which implies that their deficits lie solely in the perceptual domain. Differences that were found are indicative of this perceptual problem. However, these findings will have to be confirmed in future studies.

## **References**

Aschersleben, G. (2001) Temporal Control of Movements in Sensorimotor Synchronization. Brain and Cognition. 48. 66-79

Ayotte, J., Peretz, I., Hyde, K. (2002) Congenital amusia. A group of adults affected with a music-specific disorder. Brain. 125. 238-251

Collier, G. L., Ogden, R. T. (2004) Adding Drift to the Decomposition of Simple Isochronous Tapping: An Extension of the Wing-Kristofferson Model. Journal of Experimental Psychology: Human Perception and Performance. 30(5). 853-872

Crawford, J. R., Garthwaite, P. H. (2002) Investigation of the single case in neuropsychology: confidence limits on the abnormality of test scores and test score differences. Neuropsychologia. 40(8) 1196-1208

Dalla Bella, S., Peretz, I. (2003) Congenital Amusia Interferes with the Ability to Synchronize with Music. Annals of the New York Academy of Sciences. 999. 166-169

Del Olmo, M. F., Cheeran, B., Koch, G., Rothwell, J. (2007) Role of the Cerebellum in Externally Paed Rhythmic Finger Movements. Journal of Neurophysiology. 98. 145-152

Di Pietro, M., Laganaro, M., Leeman, B., Schnider, A. (2004) Receptive amusia: temporal auditory processing deficit in a professional musician following a left temporo-parietal lesion. Neuropsychologia. 42. 868-877

Drake, C., Bertrand, D. (2001) The Quest for Universals in Temporal Processing in Music. Annals of the New York Academy of Sciences. 930. 17-27

Drake, C., Palmer, C. (1993). Accent structures in music performance. Music Perception. 10(3). 343-378

Drake, C., Riess Jones, M., Baruch, C. (2000) The development of rhythmic attending in auditory sequences: attunement, referent period, focal attending. Cognition. 77(3) 251-288

Foxton, J. M., Nandy, R. K., Griffiths, T. (2006) Rhythm deficits in 'tone deafness'. Brain and Cognition. 62. 24-29

Fraisse, P. (1963) The Psychology of Time. New York. Harper and Row.

Grahn, J. A., Brett, M. (2007) Rhythm and Beat Perception in Motor Areas of the Brain. Journal of Cognitive Neuroscience. 19(5). 893-906

Greene L. S., Williams H. G. (1993) Age-related differences in timing control of



repetitive movement: application of the Wing-Kristofferson model. Research Quarterly for Exercise and Sport. 64(1). 32-8

Griffiths, T. D., (2003) Functional Imaging of Pitch Analysis. Annals of the New York Academy of Sciences. 999. 40-49

Griffiths, T., Rees, A., Green, G. R. (1999) Disorders of human complex sound processing. Neurocase. 5. 365-378

Grube, M., Griffiths, T. (in press) Metricality-enhanced temporal encoding and the subjective perception of rhythmic sequences. Cortex

Handel, S. (1989). Listening : an introduction to the perception of auditory events. Mass., London. MIT Press

Hyde, K. L., Peretz, I. (2004) Brains That Are out of Tune but in Time. Psychological Science. 15(5) 356-360

Iversen, J. R., Patel, A. D. (in press) The Beat Alignment Test (BAT): Surveying beat processing abilities in the general population, in M. Adachi et al Proceedings of the 10th Intl. Conf. on Music Perception and Cognition, August 2008

Jäncke, R., Loose, R., Lutz, K., Specht, K., Shah, N. J., (2000) Cortical Activations during finger paced finger -tapping applying visual and auditory pacing stimuli. Brain Research and Cognitive Brain Research. 10. 51-66

Keele, S. W., Pokorny, R. A. Corcos, D. M., Ivry, R. (1985) Do Perception and Motor Production share common timing mechanisms: A correlational analysis. Acta Psychologica. 60. 173-191

Lerdahl, F., Jackendoff, R. (1983) A generative theory of tonal music. Mass, London. MIT Press

Lewis, P. A., Wing, A. M., Pope, P. A., Praamstra, P., Miall, R. C. (2004) Brain activity correlates differentially with increasing temporal complexity of rhythms during initialization, synchronization, and continuation phases of paced finger tapping. Neuropsychologia. 41(10). 1301-1312

Liégeois-Chauvel, C., de Graaf, J. B., Laguitton, V., Chauvel, P. (1999) Specialization of Left Auditory Cortex for Speech Perception in Man Depends on Temporal Coding. Cerebral Cortex. 9 (5). 484-496

Liégeois-Chauvel, C., Giraud, K., Badier, J-M., Marquis, P., Chauvel, P. (2001) Intracerebral Evoked Potentials in Pitch Perception Reveal a Functional Asymmetry of the Human Auditory Cortex. Annals of the New York Academy of Sciences. 930. 117-132

Liegeois-Chauvel, C., Peretz, I., Babai, M., Laguitton, V., Chauvel, P. (1998) Contribution of different cortical areas in the temporal lobes to music processing.

Brain. 121. 1853-1867.

Madison, G. (2001) Variability in Isochronous Tapping: Higher Order Dependencies as a Function of Intertap Interval. Journal of Experimental Psychology: Human Perception and Performance. 27.(2). 411-422

Mendez, M. (2001) Generalized auditory agnosia with spared music recognition in a left-hander. Analysis of a case with a right temporal stroke. Cortex. 37. 139-150

Molinari, M., Leggio, M. G., Thaut, M. H. (2007) The cerebellum and neural networks for rhythmic sensorimotor synchronization in the human brain. The Cerebellum. 6(1) 18-23

Müller, K., Schmitz, F., Schnitzler, A., Freund, H-J., Aschersleben, G., Prinz, W. (2000) Journal of Cognitive Neuroscience. 12(4). 546-555

Murayama, J., Kashiwagi, T., Kashiwagi, A., Mimura, M. (2004). Impaired pitch production and preserved rhythm production in a right brain-damaged patient with amusia. Brain and Cognition. 56(1) 36-42

Patterson, R. D., Uppenkamp, S., Johnsrude, I. S., Griffiths, T. D. (2002) The Processing of Temporal Pitch and Melody Information in Auditory Cortex. Neuron. 36. 767-776

Pearce, J. M.S. (2005) Selected Observations on Amusia. European Neurology. 54. 145-148

Penhune, V. B., Doyon, J. (2002) Dynamic cortical and subcortical networks in learning and delayed recall of timed motor sequences. The Journal of Neuroscience. 22(4). 1397-406

Penhune, V. B., Zatorre, R. J., Evans, A. C. (1998) Cerebellar Contributions to Motor Timing: A PET Study of Auditory and Visual Rhythm Reproduction. Journal of Cognitive Neuroscience. 10 (6). 752-765.

Peretz, I., Champod, A. S., Hyde, K. (2003) Varieties of Musical Disorders: The Montreal Battery of Evaluation of Amusia. Annals of the New York Academy of Sciences. 999. 58-75

Peretz, I., Coltheart, M. (2003) Modularity of Music Processing. Nature Neuroscience. 6(7) 688-691

Peretz, I., Hyde, K. (2003) What is specific to music processing? Insights from congenital amusia. Trends in Cognitive Sciences. 7(8) 362-367

Piccirilli, M., Sciarra, T., Luzzi, S. (2000) Modularity of music: evidence from a case of pure amusia. Journal of Neurology, Neurosurgery and Psychiatry. 69. 541-545

Povel, D-J., Essens, P. (1985) Perception of temporal patterns. Music Perception.

2(4). 411-440

Praamstra, P., Turgeon, M., Hesse, C. W., Wing, A. M., Perryer, L. (2003) Neurophysiological correlates of error correction in sensor motor-synchronization. NeuroImage. 20. 1283-1297

Repp, B. (2001) Phase correction, Phase resetting, and phase shifts after subliminal perturbations in sensorimotor synchronization. Journal of Experimental Psychology: Human Perception and Performance. 27(3) 600-621

Repp, B. (2005) Sensorimotor synchronization: A review of the tapping literature. Psychonomic Bulletin and Review. 12. 969-992

Repp, B., Keller, P. E. (2004) Adaptation to tempo changes in sensorimotor synchronization: effects of intention, attention, and awareness. The Quarterly journal of experimental psychology. 57(3). 499 -521

Sakai, K., Hikosaka, O., Miyauchi, S., Takino, R., Tamada, T., Kobayashi Iwata N., Nielsen, M. (1999). Neural Representation of a Rhythm Depends on Its Interval Ratio. The Journal of Neuroscience. 19(22). 10074-10081

Semjen, A., Schulze, H-H., Vorberg, D. (2000) Timing precision in continuation and synchronization tapping. Psychological Research. 63. 137-147

Stavrinou, M. L., Moraru, L., Cimponeriu, L., Della Penna, S., Bezerianos, A. (2007) Evaluation of Cortical Connectivity During Real and Imagined Rhythmic Finger Tapping. Brain Topography. 19. 137-145

Stephan, K. M., Thaut, M. H., Wunderlich, G., Schicks, W., Tian, B., Tellman, L., Schmitz, T., Herzog, H., McIntosh, G. C., Seitz, R. J., Homberg, V. (2002) Conscious and Subconscious Sensorimotor Synchronization-Prefrontal Cortex and the Influence of Awareness. NeuroImage. 15. 345-352

Stevens, L. T. (1886) On the time-sense. Mind. 11. 393-404.

Stewart, L., von Kriegstein, K., Warren, J. D., Griffiths, T. D. (2006) Music and the Brain: disorders of musical listening. Brain. 129. 2533-2553

Vanneste, S., Pouthas, V., Wearden, J. H. (2001) Temporal Control of Rhythmic Performance: A Comparison Between Young and Old Adults. Experimental Aging Research. 27. 83-102

Wallin, N., Merker, B., Brown, S. (2000) The origins of music. Mass., London. MIT Press

Wing, A., Kristofferson, A. B. (1973a) The timing of interresponse intervals. Perception and Psychophysics. 13(3). 455-460

Wing, A., Kristofferson, A. B. (1973b) Response delays and the timing of discrete

motor responses. Perception & Psychophysics. 14(1). 5-12

Zatorre, R. J. (2003) Music and the Brain. Annals of the New York Academy of Sciences. 999. 4-14

Zatorre, R. J., Belin, P., Penhune, V. B., (2002) Structure and Function of Auditory Cortex: Music and Speech. Trends in Cognitive Sciences. 6(1). 37-46

# Appendices

## Appendix 1: Max/MSP patches for synchronization and continuation tasks

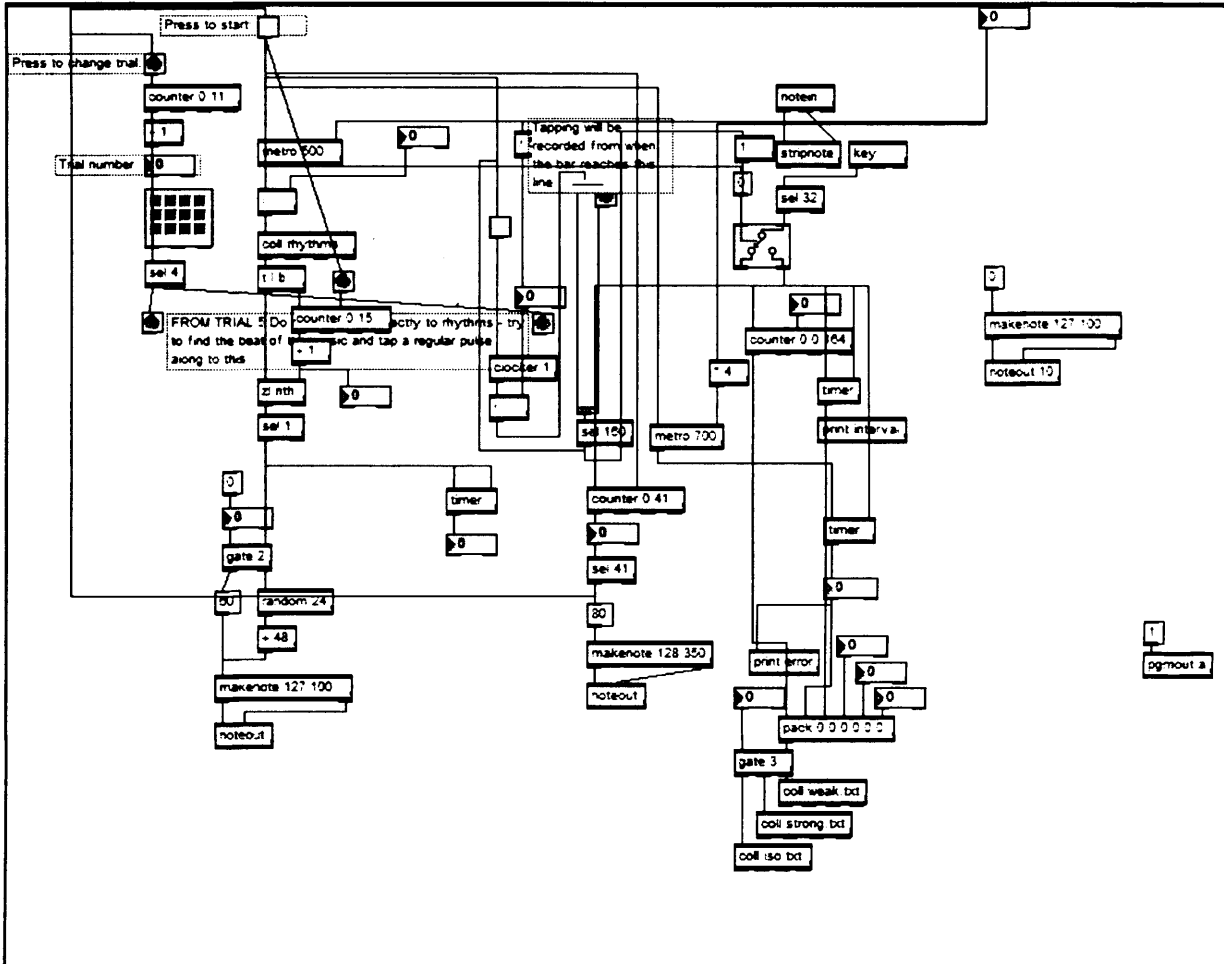

Screenshot showing system created to measure intertap interval and asynchrony for each tap produced by subjects over 12 trials in synchronization task.

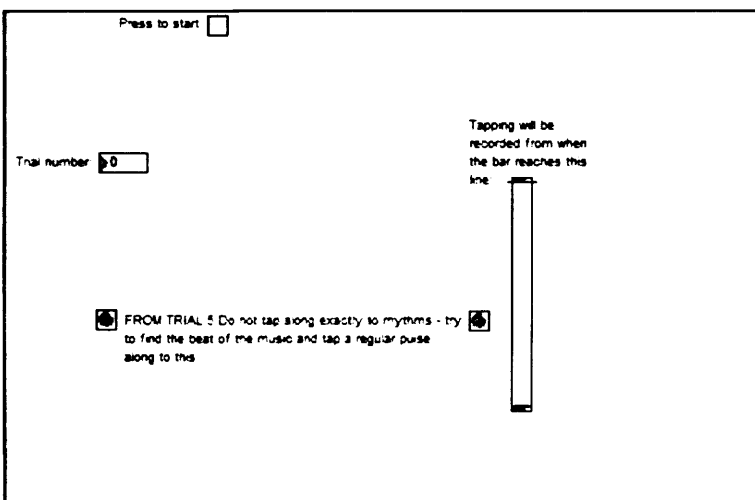

Screenshot showing user interface for subjects performing synchronization task

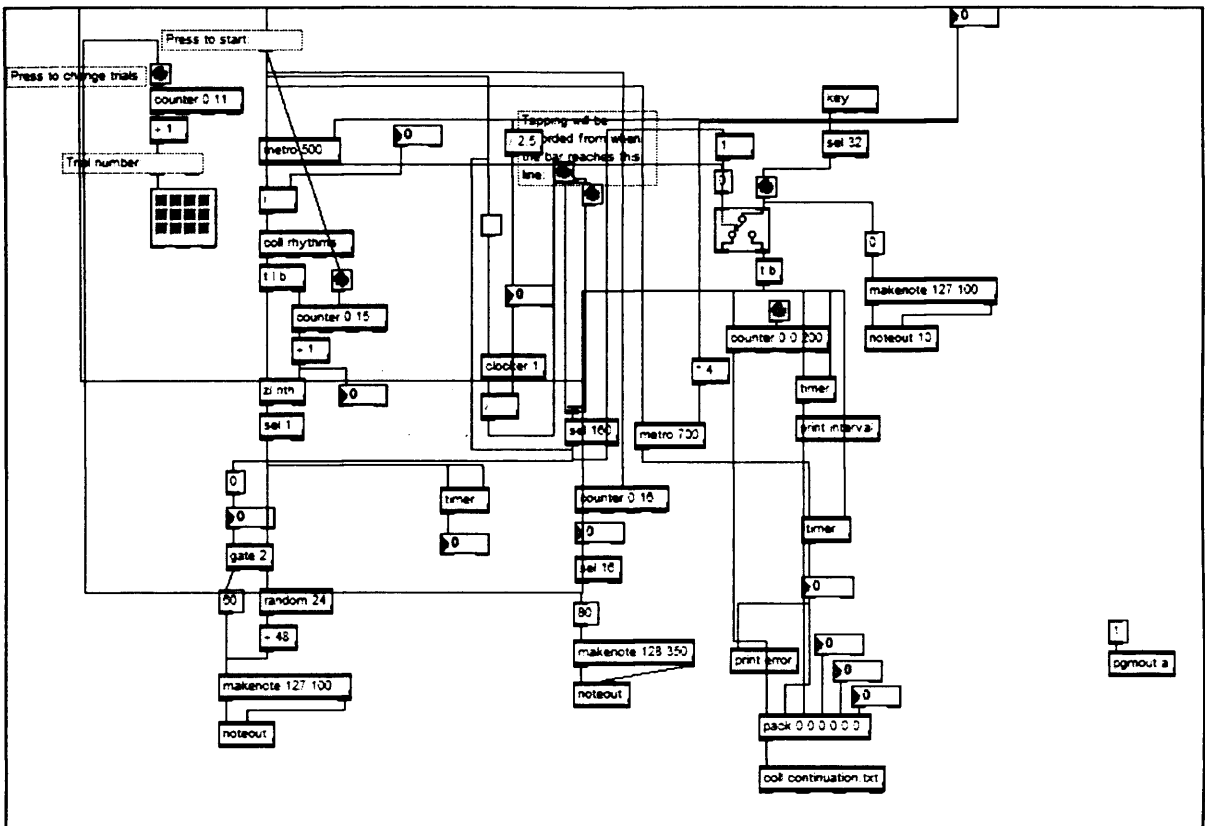

Screenshot showing system created to measure intertap interval and asynchrony for each tap produced by subjects over 12 trials in continuation task.

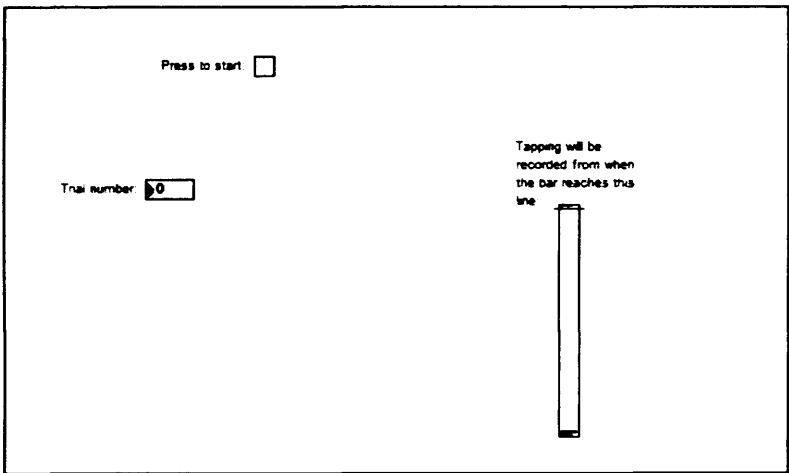

Screenshot showing user interface for subjects performing continuation task

Appendix 2: Subject information table including all scores on MBEA, age, gender, NART scores and digit span scores:

SubjectNo.	Age	Gender	MBEA:Scale	MBEA:Contour	MBEA:Interval	MBEA:Rhythm	NART	Digit span
1	56	M	28	28	28	29	43	24
2	35	M	26	28	26	27	39	26
3	33	F	29	29	30	30	41	26
4	60	M	30	27	29	30	37	23
5	35	F	30	30	30	30	41	25
6	19	F	28	30	28	29	44	24
7	24	M	29	28	27	29	42	24
8	61	F	29	30	29	30	36	22
9	35	F	29	28	28	27	38	22
10	30	F	30	29	29	30	41	22
11	24	F	29	28	27	28	40	23
12	25	M	30	29	30	30	45	22
13	25	F	29	29	27	28	41	23
14	47	F	29	28	28	26	42	21
15	56	F	28	25	23	28	45	24
16	58	F	24	26	25	27	43	26
17	55	F	29	30	29	30	42	24
18	29	F	27	30	28	28	47	23
19	25	F	28	27	29	29	43	22
20	45	F	30	30	28	27	45	25
21	41	F	26	25	27	28	44	24
22	35	M	29	29	28	29	46	25
23	60	M	27	28	29	29	48	30
24	44	M	30	29	29	30	45	27
25	42	M	24	26	24	24	45	26
26	26	F	30	29	29	30	41	21
27	44	M	26	29	30	26	43	28
28	29	M	28	29	27	27	37	20
29	56	F	26	25	22	27	41	19
30	41	F	28	29	29	28	43	28
31	34	F	29	29	30	30	46	25
32	23	M	30	30	30	30	45	29
33	40	M	28	27	26	28	43	28
34	51	M	27	22	23	24	41	23
35	35	M	25	27	25	29	40	22
36	36	M	28	28	27	28	N/A*	26
37	42	M	22	27	27	29	47	23
38	23	M	27	26	26	28	39	27
39	26	F	29	25	24	22	41	28
40	43	M	28	30	27	21	42	22
41	29	F	29	26	27	20	35	24

\*This subject used the NART as part of their job so was already familiar with the correct responses

### Appendix 3: Excluded Subjects

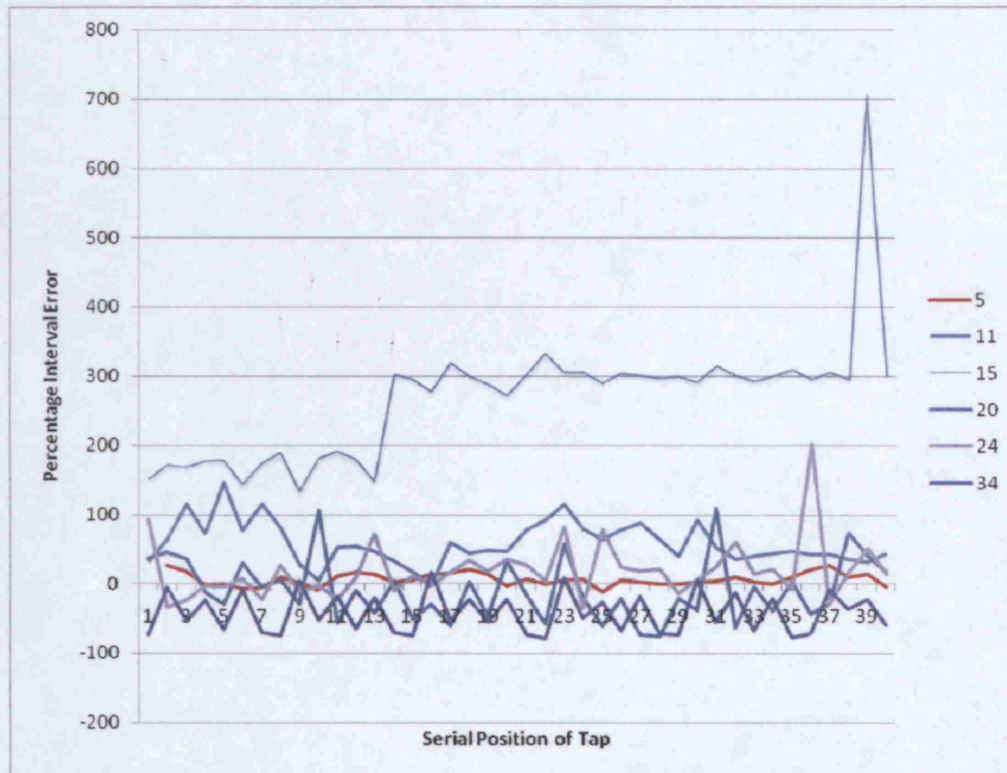

This graph shows subjects excluded on the basis of abnormal ITI's in trial 9 (with weak rhythm, no pitch changes, and 600ms tempo). Subject 5 is given as a well performing comparison.