

**Kelsey, J.M. Balancing operating revenues and occupied refurbishment costs 2:
a Space Syntax approach to locating hoardings**
(submitted to *Building Research and Information*)

Balancing Operating Revenues and Occupied Refurbishment Costs 2: A Space Syntax approach to locating hoardings

John Kelsey

Bartlett School of Construction and Project Management, Faculty of the Built Environment
University College London, Wates House, 22 Gordon Street, LONDON WC1H 0QB
j.kelsey@ucl.ac.uk

By placing hoardings in publicly accessible areas while carrying out phased occupied refurbishments, a contractor is temporarily redesigning that area. This re-configuration affects the normal pedestrian flows through such areas. A technique for the analysis of such flows has been developed under a general area of research called Space Syntax. This demonstrates the extent to which visual barriers both constrain and promote pedestrian movement. The main analytical techniques used are Axial analysis and Visibility Graph Analysis which are based upon lines or areas of visibility. Empirical evidence is presented in observations carried out at London Victoria Station before and during a small refurbishment project involving the temporary closure of a single entrance. This evidence is in line with previous Space Syntax studies. The relationship between changes in the station configuration and visitor numbers to retail outlets suggests the need to place hoardings in such a way that both movement and browsing areas remain spatially separated but visually connected. This is also suggested by previous Space Syntax studies and is incorporated into a brief set of general guidelines for clients and contractors to assist the minimisation of disruption to pedestrian movement in publicly accessible areas.

Keywords: Space Syntax, axial analysis, visibility graph analysis, occupied refurbishment, pedestrian modelling

Introduction

This is the second of two papers dealing with decision-making problems in occupied refurbishment. The first paper (Kelsey, forthcoming) took an overview of the whole process both at the strategic and site planning levels. In this paper a particular technique is examined at the site planning level which has hitherto not been associated with construction planning although extensively used in the design and planning of both buildings and urban environments.

One of the needs identified in the site level decision process is a modelling technique to predict changes in pedestrian movement and browsing behaviour as a result of changing the spatial layout of a public area during phased refurbishment works. This is provided through an area of research known as Space Syntax for which there is a considerable literature.

Firstly the two basic analytical methods associated with Space Syntax are described at some length for the benefit of readers, most of whom are unlikely to have encountered these before. A brief outline then follows of the applications in which such methods have been used. Then some data is presented which relates to one of the railway station case studies described in Kelsey (forthcoming). An example of how hoarding locations might be improved is then given. Finally a set of general rules for

minimising pedestrian disruption is given together with other considerations essential in temporarily re-configuring the public space outside the site boundary.

Previous research

A group of researchers in University College London have, for over 20 years, been looking at the interrelationship of society with the spaces created by the built environment. Much of the work of the Bartlett involves researching and teaching the planning of urban communities together with the design/construction of buildings and the management of projects. However the 'Space Syntax' group have been involved in examining how the existing built environment is both affected by and itself affects society.

In particular they have looked at the way both the spaces within and the spaces between buildings are shaped by and shape the activities carried on within or around those buildings - especially the pattern of vehicular and pedestrian flows in the urban environment. They deliberately use the term 'syntax' to point to an analogy with language. Humans learn from a very early age to put words together in a certain way to make meaningful sentences. The spaces created by the built environment have a set of interrelationships. As with the syntax of human language these show patterns which can be investigated and analysed.

At one level these spatial relationships can be seen as both expressing and helping to conserve (or disrupt) particular social relationships (Hillier and Hanson 1984). At another level, observation of how people move to and through these spaces can reveal something of the way individuals navigate through space and perceive some spaces to be preferable to others (Penn 2001, Hillier and Iida 2005). Much of the analysis which follows presents abridged and simplified versions of arguments set out in Hillier and Iida (2005) and Turner *et al.* (2001).

Method 1 - Axial analysis

Let us take an example of a small group of streets as in Figure 1. Here the blocks represent buildings which extend right up to the pavement. The intervening space represents both road and pavement space. The edges of the whole have to be 'closed' in order to form a boundary to the system.

Now the aim is to draw the fewest number of connected straight lines which can cover the whole street area. This forms the 'axial map' which is used for analysis. These are represented by the dotted lines in Figure 1. The process of doing this is rather more complicated than can be described here (Turner *et al.* 2005) but Figure 1 will serve as a good approximation.

It is important to note that the lines are not the central lines of the road grid. They represent long(est) lines of *visibility* from particular points. While in practice, using the central lines of the road (parallel with the building edges) might produce a similar result, Space Syntax is used to analyse both cities and buildings with far more irregular patterns than shown in Figure 1. It is essential to have rules (based on visibility) which adequately cover all such cases.

Having obtained the basic axial amp of an urban area, it can then be represented as a network in the form of a (mathematical) graph as in Figure 2.

A small street grid

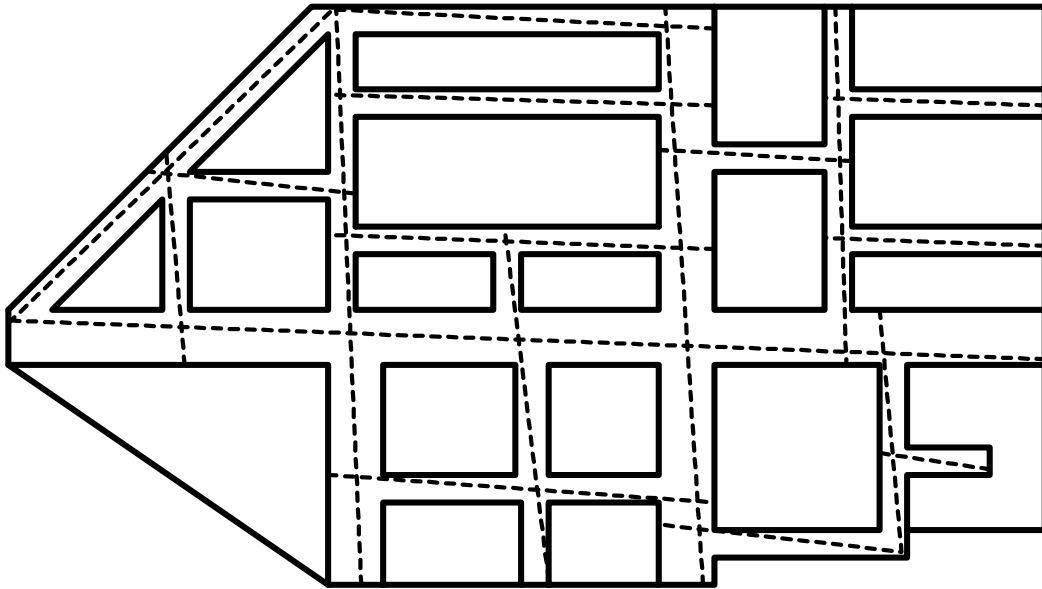

Figure 1

Looking at this graph, we can ask two questions about this road system. The first is which points are (on average) closer to all the other points in the system. Clearly points B and C are the likely candidates with points such as X or Z coming at the bottom of the list. The second is which points lie on more than any other of the available routes which connect the whole system.

Graph representation of the street network

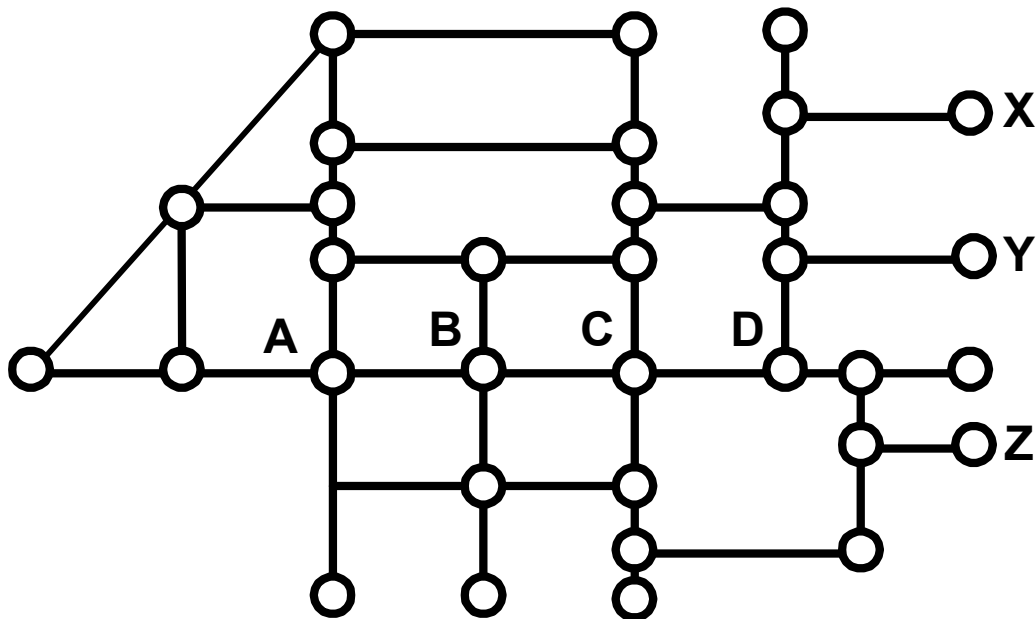

Figure 2

This is a network property called 'betweenness'. Again clearly points such as X, Y and Z will come at the bottom of the list whereas points A, B, C and D will be at the top.

This property of 'betweenness' becomes more important as an area is embedded into a large urban area. If Figure 2 merely represents the total network of an isolated country village, the 'closeness' aspect will dominate as people will tend to take mostly local journeys (or journeys to and from the network rather than through it). If, however, the network is embedded in a much larger urban area then the 'betweenness' aspect will dominate and points A and C (certainly) and maybe the line A-D will exhibit a much superior 'global betweenness' (within the whole urban area) than 'local betweenness' (within the network in Figure 2).

There is a further property however which makes A, B, C and D better candidates than other points. If we were to limit routes between points to those with the *fewest turns* (i.e. with the least wayfinding complexity) then clearly the line connecting A-D will be the most travelled line. Alternatively if we were to restrict all journeys to those with (say) only two turns, points A, B, C and D would similarly come up as winners.

Space Syntax analysts tend to look at the lines rather than the places they join. So they describe line A-D as one having 'high integration' (with the surrounding area) and those proceeding from points X, Y and Z as having 'low integration'. In standard Space Syntax presentation, lines with high integration are coloured red and those with low integration are coloured blue with appropriate spectrum colours for intermediate values. Clearly that cannot be reproduced here but it does give analysts a highly visually communicative tool with which to show patterns of urban 'integration'.

There is one obvious property of this network that has been omitted namely the physical distance of the lines between the 'nodes' of the network. Intuitively one would think that movement would be determined using the shortest physical distance between journey origin and destination.

However a study by Penn *et al.* (1998) shows otherwise. They studied four areas of London and compared observed vehicular and pedestrian flows and compared them with closeness and betweenness values and values based on a) physical distance, b) (total) angles of turns and c) fewest turns. Clearly b) is a more sophisticated version of c) but is a further, more recent refinement (Turner 2001) which we will not go into here. Both b) and c) proved superior to a) as predictors of urban movement. R^2 regression values of around 0.6 were obtained for pedestrian movement and around 0.7 for vehicular movement.

This provides evidence that urban configuration and wayfinding complexity are important determinants of urban movement patterns. Low wayfinding complexity (i.e. small numbers of turns) is associated with areas of *high* integration values and *vice versa*. This also provides evidence of the inadequacy of origin-destination models described in paper one in predicting changes in pedestrian behaviour as a result of changing the layout of a public area.

Method 2 - Visibility Graph Analysis (VGA)

Axial analysis is based on lines of visibility. What happens when we look at spaces of visibility in (say) open spaces or inside buildings? If we extend from the one dimension of axial analysis into (at least) two dimensions we can extend the idea of the axial line (the longest line(s) of visibility in a street or corridor) to the idea of an 'isovist' or the total space (area) which can be viewed from a single point. (For the purposes of this paper the analysis is restricted to two dimensions.)

Let us take a rectangular area bounded by a wall and containing a T-shaped visual obstruction as shown in Figure 3a. The isovist is the area visible from point A. A person standing at point A can see point C but not point B. If we add another isovist from point B (Figure 3b) then people standing at points A and B cannot see each other but could see someone standing at point C. C therefore provides an important visual link between A and B.

View of the areas of visibility ('isovists') from a) one point and b) two points

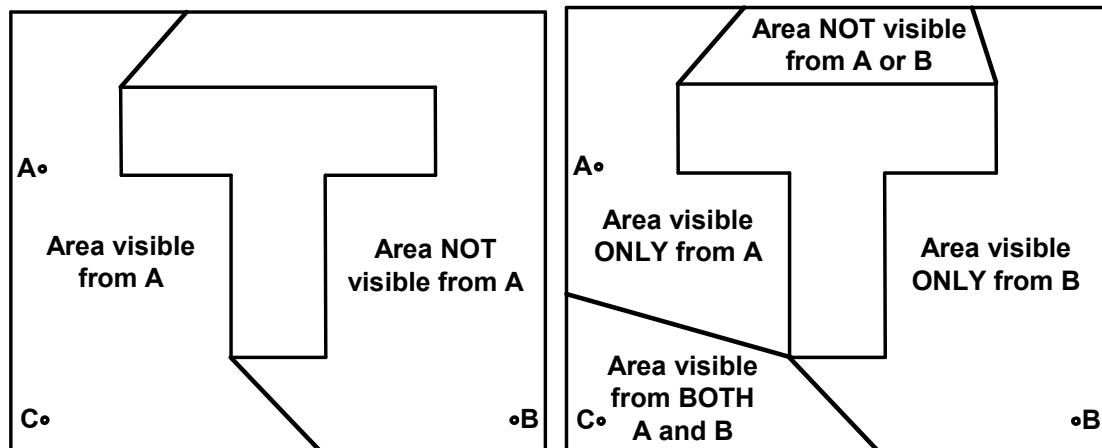

Figure 3

a) First-order visibility graph and b) VGA relative integration values

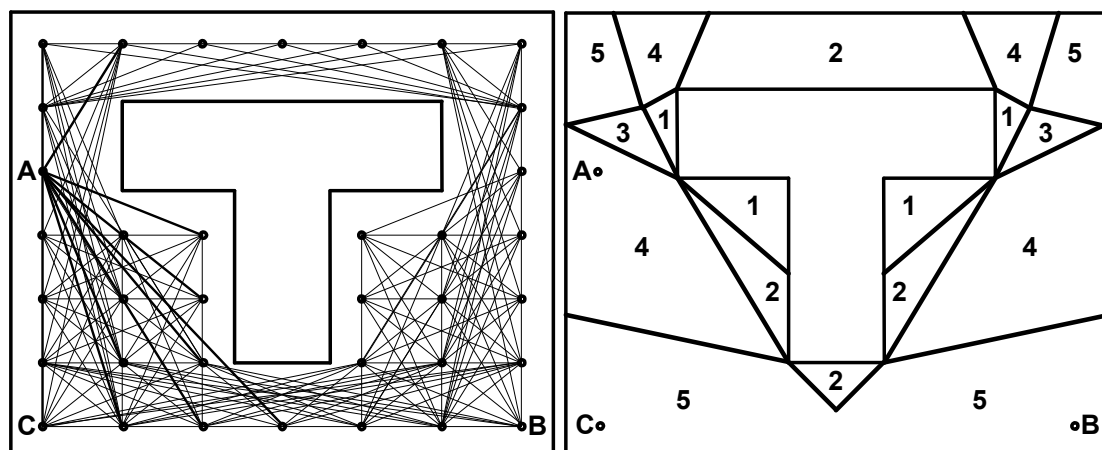

Figure 4

What is needed is a means of analysing all the points in the space and their visual connectedness to all the other points in the same space. Now clearly there is a theoretically infinite number of points so what is used is a lattice of points within the space. A graph is produced based on all the points and all the points that are visible from each point as in Figure 4. It should be noted that it is only the advent of modern computing power which makes this sort of analysis a practical proposition.

In practice the lattice would be more finely grained (i.e. the dots closer together) than is shown in Figure 4a. This is a 'first-order' visibility graph which shows all the direct visual connections between all the points.

In measuring the connectedness of spaces, several properties can be used. The first is the idea of *neighbourhood size* which is basically the number of immediately visible points. It can be seen by inspection that this is greater for points B and C than it is for A. It can also be seen that it is particularly low for the narrow corridor 'above' the 'T'. This value gives a sense of the direct visual connectedness of any point within the whole space relative to any other point.

The second property which interests us is what Turner *et al.* (2001) refer to as a *clustering coefficient* although isovist network density might be an alternative term.

a) Visibility network (graph) and b) Complete network of the 'A' isovist

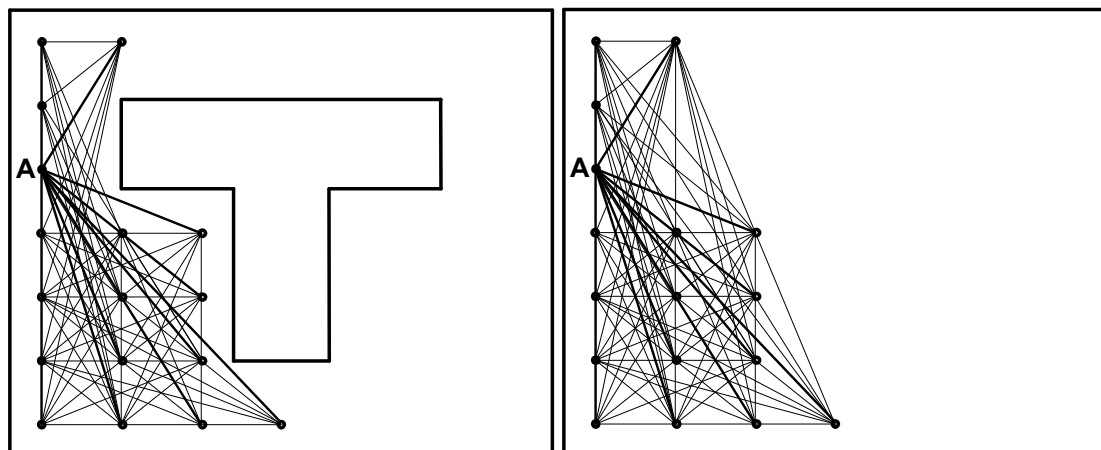

Figure 5

This is calculated as the number of connections in the visibility network (Figure 5a) divided by the total possible number of connections in the network (i.e. with the visual obstacle removed) (Figure 5b). This gives a measure of the *convexity* of the isovist which expresses its *local or internal visual connectedness*. Conversely it measures the extent to which the visual obstacle 'disrupts' the local visual connectedness of the isovist. It is a purely local property of the isovist itself rather than the whole space. It is also a measure of the extent to which the view of the space occupied by the isovist changes as an individual moves around it. A high value indicates a low degree of visual complexity and *vice versa*.

Finally and possibly the most important is the third measure of interest namely that of *mean shortest path length*. Put simply we ask how many lines of sight on average do

you have to go through to get from any point in the whole space to get to any other point. This is analogous to the *fewest turns* idea encountered earlier in axial analysis. So, for instance in Figures 3/4, the path length from A to C is 1, from C to B is 1 and from A to B is 2. In a network consisting only of A, B and C the mean average path length would be $1.5 \left(\frac{1 + 2}{2} \right)$ for A or B and $1 \left(\frac{1+1}{2} \right)$ for C. In this 'mini-network' point C is the key point of integration.

In the larger network (Figure 4a) B and C are equivalent points and will display a shorter mean path length than A which is in a less well 'integrated' space. The relative degree of integration is shown in Figure 4b. As with the axial maps these are normally presented in spectrum colours with red for the high values and blue for the low values. The areas also shade into one another rather than being sharply divided by lines. Again this makes for a visually communicative presentation of spatial properties.

As with the study of external urban areas, a study of the Tate Gallery (Hillier *et al.* 1996) demonstrated that 'fewest turns' connectivity of internal building spaces was also a good predictor of movement patterns within the building and superior to origin-destination modelling based on actual physical length between locations. It also corresponded well with observed occupancy rates in various spaces within the Tate Gallery which suggests that such spaces are desirable places to be in as well as being desirable pathways to other spaces.

Application

The applications to which these findings can be put are so considerable that UCL has been able to start a commercial consultancy which now operates as an independent business under the name of Space Syntax Ltd. A full list of their work can be found at www.spacesyntax.com. The main types of uses are the analysis of the configurational effect on existing space use and the examination of and suggestions for proposals for alteration of existing spaces and the creation of new ones. One example is the Swiss Re building in London (popularly known as the 'gherkin') where the number and placing of ground floor entrances were determined using Space Syntax methods.

However these methods have not hitherto been applied to analysing the impact of phased building refurbishment on the spatial operations of clients whose business remains open during the works.

London stations not only act as railway termini but, as a result of this primary activity, are also highly profitable retail areas. A well known retail chain has its most profitable branch located in one of London's stations. (It has been found that a considerable number of visitors to London stations are there for the retail facilities and are not there to travel.) Railtrack identified a business opportunity in the redevelopment of certain retail units at London Victoria Station which would allow a greater number of units to be created. During the refurbishment works it became apparent that the contractor was experiencing logistical problems and asked to have a larger working area which involved the closure of one of the entrances to the station.

The entrance was duly closed and Space Syntax observers were used to record movement activity before and after the change (Space Syntax 2001). They recorded (among other things) the change in use of the station entrances (Table 1) and changes

in number of people entering certain establishments (Table 2). UCL could only look at the visitor numbers to various outlets before and after the closure as actual retail revenue (and even periodic percentage changes) is very closely guarded and commercially sensitive information. It should be noted that there were 15% less visitors to the station for the observation period after the entrance closure than before it (for reasons entirely unconnected with the closure) and that therefore -15% should be regarded as the 'expected' change (rather than 0%).

As mentioned earlier, Space Syntax output is normally presented in the form of complex, highly coloured maps of buildings and urban areas with red areas/lines representing highly integrated areas/routes and blue/indigo/violet representing poorly integrated or segregated areas/routes. (Likewise intermediate colours on the spectrum show intermediate integration values.) In addition, a loglinear regression analysis can demonstrate the relationship between observed movement and movement predicted by relative integration values in the form:-

$$\ln(y) = a + b(\ln(x)) + e$$

where y is a measure of mean observed movement through any point, x is the relative integration value of any point, e is an error term and a, b are constants. For movement through various observation points inside Victoria station the following values were obtained:-

$$\ln(y) = 3.786 + 3.268(\ln(x)) + e_i \quad (R^2 = 0.731)$$

before the closure of one of the entrances and

$$\ln(y) = 4.051 + 2.825(\ln(x)) + e_j \quad (R^2 = 0.672)$$

after the closure of one of the entrances during the refurbishment works.

London Victoria Station - changes in movement through entrances before and after temporary closure of Entrance 4

Entrance	% change in movement
1	-21.9
2	-20.6
3	-38.3
4	CLOSED
5	+109.8
6	+20.7
7	-11.7
8	-3.6
9	-70.6
10	-14.0

Table 1

Thus the axial analysis of the station was correlated with 73% of the observed pedestrian movement into and out of the station before the entrance closure and 67%

after it. This confirms the findings in the London studies referred to earlier (Penn *et al.* 1998)

London Victoria Station - changes in entry into selected outlets before and after temporary closure of Entrance 4

Outlet	% change in visitors
A	-7
B	+28
C	+6
D	no change
E	-31
F	-41
G	-9
H	-58
I	-14
J	-34
K	-4
L	+12

Table 2

Visibility Graph Analysis was used to look at the more complex relationship between areas used for movement and areas used for standing within the station area. The colour-based maps cannot be displayed here but we can take look at one outlet namely H (Figure 6).

Local spatial configuration before and after the entrance closure

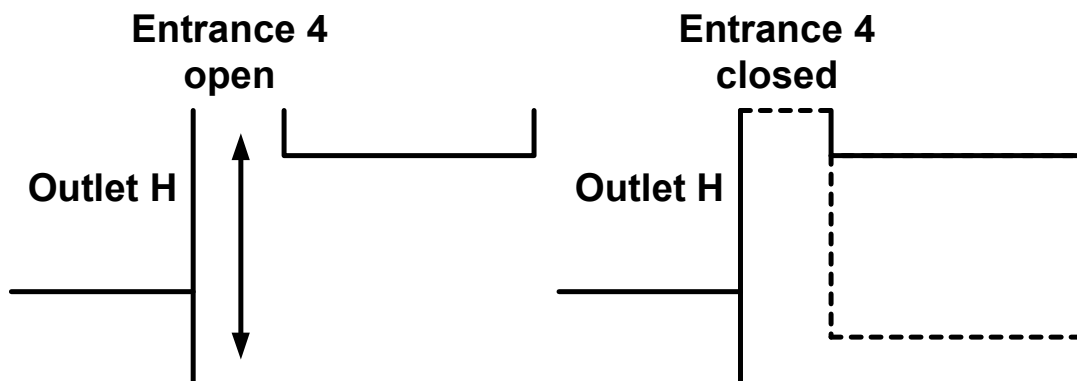

Figure 6

The closure of the station entrance and the erection of the contractor's hoarding (shown by the dotted line) not only removed passing pedestrian traffic but effectively cut off outlet H from the visual field of most of the rest of the concourse. Not surprisingly it suffered the greatest drop in visitors (Table 2). Fortunately Railtrack, being warned that this might happen, relocated a non-commercial user in outlet H and so did not suffer financially from the drop in visitors to that outlet.

Problem areas

These methods are not without controversy. Ratti (2004) suggests a number of inconsistencies and the replies to the most significant of them are drawn from Hillier and Penn (2004).

- i) Small changes in urban formation can give rise to significant changes in the axial analysis. Looking at Figures 1 again, it can be seen that quite small changes in the configuration might give rise to changes in the network because some lines are 'just about visible' particularly where they just miss corners of buildings. However, in various studies (Hillier 1996 and 2002) of historic urban areas, regular patterns are found in some cultures where city patterns exhibit 'just about visible' properties and conversely in other cultures they exhibit 'just about not visible' properties which give rise to a more complex network. It is precisely the presence of regular 'just about' properties which are part of the reason that Space Syntax has such analytic power.
- ii) Space syntax takes no account of building height. This is true because part of the aim of Space Syntax research is to observe the effects of configuration alone upon pedestrian movement. However Penn *et al.* (1998) also modelled building height as a variable. They found that although this had some local significance it was still substantially less than the configuration values in a multivariate analysis.
- iii) The analysis is affected by where the boundary line is drawn. This is correct but every 'local' analysis is complemented by an analysis where the boundary line is well away from that of the locality so that both local and more global properties of a grid can be observed. In the latter case the 'boundary' effects are negligible or disappear altogether.
- iv) The analysis ignores the land use of the buildings adjoining the configured spaces. As in ii) above part of the aim of Space Syntax research is to determine the 'pure' effect of configuration uncluttered by other variables. However in the work of the Space Syntax Ltd consultancy in modelling pedestrian movement for clients, property use may be included as a modelling variable where appropriate to determine *all* significant factors having a bearing on pedestrian movement. (It should be noted, however, that the development of land-use may itself be influenced by the configuration effects on both pedestrian and vehicular movement.)

Application to disruption in publicly accessible retail areas

So what might be learned from this and other Space Syntax studies? Additional visibility analysis in Victoria and elsewhere show that there is an important relationship between good movement and good standing areas. Fundamentally the standing areas need to be out of the main movement areas but visually well connected to them. This is also important for retail only environments.

When people shop they want space to look at the shop but have time (and space) to decide whether or not to enter the shop. They do not want to be pressured into a decision one way or the other. However people do not want to stand for any length of time in areas which are not visually well-connected to the main lines of pedestrian movement (unless they are standing there for antisocial purposes). This is where the idea of convexity is especially important.

Accordingly if we look at Figure 7a this shows the spatially ideal situation for a retail environment. If refurbishment works have to be carried out outside then arrangement 7b (with the heavy dotted line as the hoarding line) is highly undesirable because i) it increases the wayfinding complexity of the movement network and b) the movement through the standing area disrupts the function of that area to the detriment of the retailers. Likewise 7c is also undesirable because the standing area is visually detached from the movement area. A better arrangement would be 7d whereby the movement area remains separate from the standing area but is still reasonably well-connected to it visually.

Possible layout of refurbishment outside a retail area

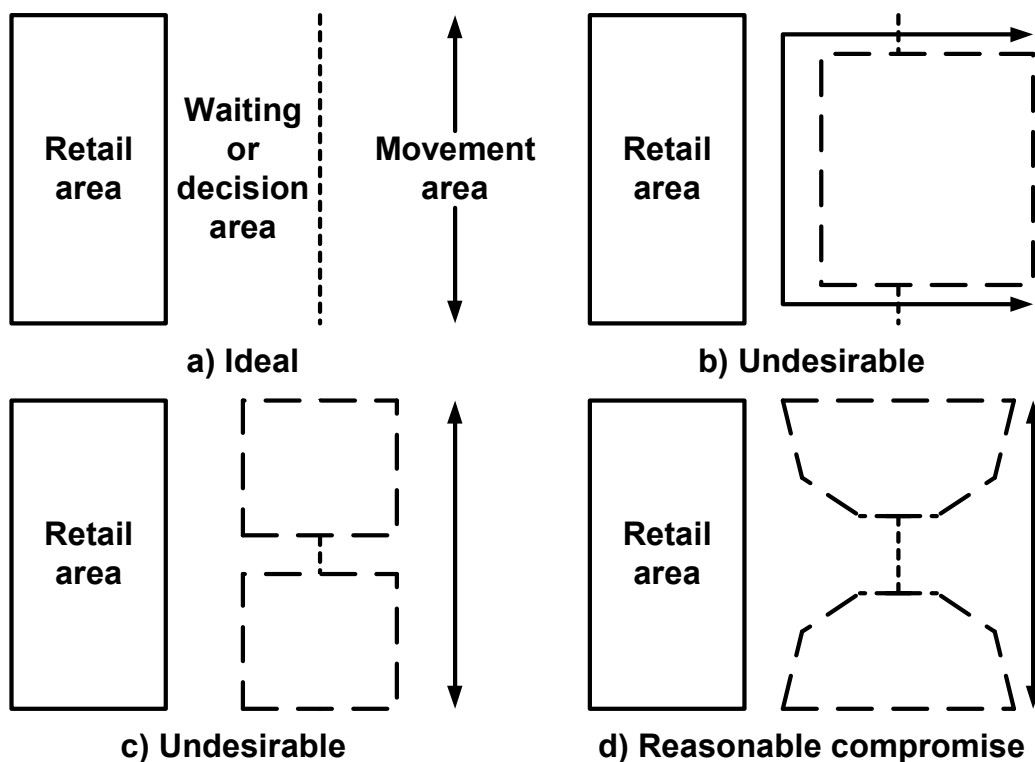

Figure 7

It might well be in 7c and 7d that there needs to be a high-level connection between the two areas (for instance if high-level services are being renewed or repaired) but one which allows the eye-level visual field (and floor-level physical movement) of the pedestrian to be minimally disrupted.

Suggested basic guidelines for refurbishment construction planners and facility managers to minimise pedestrian disruption

General

One of the aims of the research was to produce some brief basic guidelines for contractors in this area. It is important that in using these guidelines the construction planner and facility manager work together so that knowledge of a) the facility in normal operation and b) the practicalities of construction methods and associated risks, can be pooled to aid decision-making (about the phasing of refurbishment works and the location of hoardings) to bring about a minimally disruptive refurbishment.

A) Understand the operation of the facility as an internal pedestrian movement system and its relationship to the immediate environment

1. Identify the entrances/exits into and out of the facility and their relative importance in terms of pedestrian movement.
2. Identify if and to what extent there are biases in the direction of pedestrian flows.
3. Identify when flows increase/decrease or when direction bias changes (both railway stations and shopping centres exhibit peak and slack periods as well as changes in the main direction of flows).
4. Identify spaces where people tend to congregate and remain static (for example this might be in front of Customer Information Screens in stations or outside certain types of retail/food outlets in shopping centres and stations).

B) Try to predict the likely effect of closing entrances/exits or blocking major pedestrian routes or standing areas

1. Identify the likely new primary and secondary entrances/exits.
2. Identify the likely new major pedestrian routes.
3. Identify the likely new areas where static pedestrians may congregate.

C) Be aware of the factors that influence pedestrians in movement choices

1. Pedestrians prefer straight (or slightly curved) uncomplicated routes to complicated ones involving many turns.
2. Pedestrians prefer moving in directions where their visibility of surrounding areas is greatest.
3. Pedestrians prefer remaining static in areas where their visibility of surrounding areas is greatest PROVIDED they are outside the main lines of pedestrian movement.

D) Select construction phases and locations which try and match B) and C) above having regard to the time/cost/quality requirements of the client

1. Try to maximise visibility along the new primary pedestrian route(s). Ideally people should at some point be able to see from one side of the restricted area to the other although clearly this is not always possible.
2. Where the construction programme, methods and spatial logic require sharp turns in pedestrian routes then try to widen the corridor at the turn by cutting off the corners. This both helps increase general visibility and also helps prevent people bumping into one another. (It is not often that builders are recommended to cut corners but in this case it can be highly beneficial.)
3. Try to ensure that the new ‘natural’ standing areas are out of the main pedestrian flows but in visual contact with them because:
 - a. People will generally not stand for long in the middle of an area of moving pedestrians. In retailing in particular people want time and space to make a decision whether or not to enter a particular outlet – in particular to look in the shop window first and see what is on offer. If they feel hassled by other pedestrians moving round them while standing outside an outlet they will tend not to enter and the outlet will lose trade.
 - b. People do not like to stand in areas which are out of visual contact with other areas for security and other reasons. Creating a situation where potential standing areas end up in blind alleys or dead ends are particularly to be avoided. Looked at from the other direction people are less likely to leave a pedestrian flow and go to a standing area if they cannot see that area while they are moving.
4. The general rule here is to create areas which maximise the property of convexity – spaces where as many points in that space can be seen from any other point in the space.

E) Ensure that selected configurations are checked for security, fire dynamics, fire and other emergency evacuation properties by professional consultants

A phased refurbishment is also a temporary re-design of the existing facility. Hoardings can remain for months (even years). Maximising convexity (visibility) will assist in creating a more secure area and one which is more easily covered by CCTV (if that is desired). Allowing sufficient height (where temporary horizontal site divisions are required) or ‘reservoir’ areas in temporary ceilings will reduce the danger posed by smoke in the event of fire. Narrow corridors with restricted visibility present problems in both evacuation and rapidity of fire spread. Also dangerous are semi-enclosed wooden staircases or escalators. Supplementary signage will also be important in a disrupted environment. It is easier than people think to unwittingly create an unsafe environment through configuration-related causes. So consult the experts in these areas.

Conclusion

The disruption of retail or other business environments may have significant consequences on visitor numbers which may significantly affect sales. When planning phased refurbishment projects, tools are needed to assist the minimisation of spatial disruption caused by partial contractor occupation of an operating business.

The methods of analysis offered by Space Syntax provide a means to analyse the likely effects of disruption of the spatial environment upon both pedestrian movement through an area and movement to those areas within the site still open for business. These methods also suggest principles for minimising such disruption.

These methods also have wider application to problems of managing and changing the built environment. They have been proved successful in a range of applications not least because they have been based on over 20 years of research and observation of a wide range of built environments in many different parts of the world.

Future work

Further research is needed in the practical application of such tools to different types of occupied refurbishment projects and to the question of the effect on the movement of client workers (as well as the general public). Some form of action research is also needed on the possibilities of realigning site-based project management objectives.

During the course of the research project (but after the work done at Victoria) agent-based modelling tools were developed at UCL which allowed incorporation of both Space Syntax-type behaviour and more direct attractor-based behaviour which forms the basis of origin-destination pedestrian modelling. By experimenting with differing combinations of influences, it is hoped that even greater accuracy in predicting pedestrian movement can be achieved (Penn and Turner 2001 and 2002).

Acknowledgements

The author acknowledges the support of the UK Engineering and Physical Sciences Research Council (GR/N 02917/01) in carrying out this research. Assistance has also been provided by Alan Penn, Alasdair Turner, Andrew Edkins, Graham Winch, Peter McLennan, Bill Hillier, Laura Vaughan and employees of Railtrack plc (now part of Network Rail Ltd), Laing Construction Ltd (now part of the O'Rourke group), British Land plc and Space Syntax Ltd.

REFERENCES

Hillier B. (1996) *Space is the machine* CUP, Cambridge

Hillier B. (2002) A theory of the city as object: how the social construction of space is mediated by spatial laws *Urban Design International* **7(3-4)** 153-179

Hillier B. and Hanson J. (1984) *The social logic of space* CUP, Cambridge

- Hillier B. and Iida S. (2005) Network and psychological effects in urban movement in Cohn A.G. and Mark D.M. (Eds) *COSIT 2005* (Lecture Notes in Computer Science 3693) Berlin, Springer-Verlag 475-490
- Hillier B. and Penn A. (2004) Rejoinder to Carlo Ratti *Environment and Planning B: Planning and Design* **31** 501-511
- Kelsey J.M. (*forthcoming*) Balancing operating revenues and occupied Refurbishment costs 1: problems of defining project success factors and selecting site planning methods *Building Research and Information*
- Penn A. (2001) Space Syntax and spatial cognition or why the axial line? *Proceedings of the Third International Symposium on Space Syntax* Georgia Institute of Technology, Atlanta GA Ch 11
- Penn A., Hillier B., Banister D. and Xu J. (1998) Configurational modelling of urban movement networks *Environment and Planning B* **25** 59-84
- Ratti C. (2004) Space syntax: some inconsistencies *Environment and Planning B: Planning and Design* **31** 487-499
- Space Syntax Ltd (2001) *RaCMIT Case Study – Victoria Station – report on the Space Syntax study* London, a RaCMIT report
- Space Syntax Ltd (2003) – web site www.spacesyntax.com
- Turner A. (2001) Angular analysis *Proceedings of the Third International Space Syntax Symposium* Georgia Institute of Technology, Atlanta GA Ch 30
- Turner A., Penn A. and Hillier B. (2005) An algorithmic definition of the axial map *Environment and Planning B* **32** 425-444