

**OPEN ACCESS**

# The Triple GEM Detector Control System for CMS forward muon spectrometer upgrade

To cite this article: W. Ahmed *et al* 2017 *JINST* **12** P02003

View the [article online](#) for updates and enhancements.

## Related content

- [The detector control systems for the CMS Resistive Plate Chamber](#)  
G Polese, P Paolucci, R Gomez- Reino et al.
- [Status of the Triple-GEM project for the upgrade of the CMS Muon System](#)  
D Abbaneo, M Abbrescia, M Abi Akl et al.
- [Design and Performance of the ATLAS Muon Detector Control System](#)  
Alessandro Polini and the ATLAS Muon Collaboration



**IOP | ebooks™**

Bringing you innovative digital publishing with leading voices to create your essential collection of books in STEM research.

Start exploring the collection - download the first chapter of every title for free.

## The Triple GEM Detector Control System for CMS forward muon spectrometer upgrade

W. Ahmed,<sup>20,\*</sup> D. Abbaneo,<sup>18</sup> M. Abbas,<sup>18</sup> M. Abbrescia,<sup>2</sup> A.A. Abdelalim,<sup>9</sup> M. Abi. Akl,<sup>14</sup> D. Acosta,<sup>16</sup> A. Ahmad,<sup>20</sup> W. Ahmed,<sup>9</sup> A. Aleksandrov,<sup>30</sup> R. Aly,<sup>9</sup> P. Altieri,<sup>2</sup> C. Asawatangtrakuldee,<sup>3</sup> P. Aspell,<sup>18</sup> Y. Assran,<sup>8</sup> I. Awan,<sup>20</sup> S. Bally,<sup>18</sup> Y. Ban,<sup>3</sup> S. Banerjee,<sup>21</sup> V. Barashko,<sup>16</sup> P. Barria,<sup>5</sup> G. Bencze,<sup>7</sup> N. Beni,<sup>11</sup> L. Benussi,<sup>15</sup> V. Bhopatkar,<sup>24</sup> S. Bianco,<sup>15</sup> J. Bos,<sup>18</sup> O. Bouhali,<sup>14</sup> O. Holme,<sup>18</sup> A. Braghieri,<sup>27</sup> S. Braibant,<sup>4</sup> S. Buontempo,<sup>26</sup> S.A. Khan,<sup>20</sup> C. Calabria,<sup>2</sup> M. Caponero,<sup>15</sup> C. Caputo,<sup>2</sup> F. Cassese,<sup>26</sup> A. Castaneda,<sup>14</sup> S. Cauwenbergh,<sup>19</sup> F.R. Cavallo,<sup>4</sup> A. Celik,<sup>10</sup> M. Choi,<sup>34</sup> S. Choi,<sup>32</sup> J. Christiansen,<sup>18</sup> A. Cimmino,<sup>19</sup> S. Colafranceschi,<sup>18</sup> A. Colaleo,<sup>2</sup> A. Conde Garcia,<sup>18</sup> S. Czellar,<sup>11</sup> M.M. Dabrowski,<sup>18</sup> G. De. Lentdecker,<sup>5</sup> R. De Oliveira,<sup>18</sup> G. de Robertis,<sup>2</sup> S. Dildick,<sup>19</sup> B. Dorney,<sup>18</sup> W. Elmetenawee,<sup>9</sup> G. Endroczi,<sup>7</sup> F. Errico,<sup>2</sup> A. Fenyvesi,<sup>11</sup> S. Ferry,<sup>18</sup> I. Furic,<sup>16</sup> P. Giacomelli,<sup>4</sup> J. Gilmore,<sup>10</sup> V. Golovtsov,<sup>17</sup> L. Guiducci,<sup>4</sup> F. Guilloux,<sup>29</sup> A. Gutierrez,<sup>13</sup> R.M. Hadjiiska,<sup>30</sup> A. Hassan,<sup>9</sup> J. Hauser,<sup>23</sup> K. Hoepfner,<sup>1</sup> M. Hohlmann,<sup>24</sup> H. Hoorani,<sup>20</sup> A.H. Shah,<sup>12</sup> P. Iaydjiev,<sup>30</sup> Y.G. Jeng,<sup>34</sup> T. Kamon,<sup>10</sup> P. Karchin,<sup>13</sup> A. Korytov,<sup>16</sup> S. Krutelyov,<sup>10</sup> A. Kumar,<sup>12</sup> H. Kim,<sup>34</sup> T. Lenzi,<sup>5</sup> L. Litov,<sup>31</sup> F. Loddo,<sup>2</sup> A. Madorsky,<sup>16</sup> T. Maerschalk,<sup>5</sup> M. Maggi,<sup>2</sup> A. Magnani,<sup>27</sup> P.K. Mal,<sup>6</sup> K. Mandal,<sup>6</sup> A. Marchioro,<sup>18</sup> A. Marinov,<sup>18</sup> N. Majumdar,<sup>21</sup> J.A. Merlin,<sup>18</sup> G. Mitselmakher,<sup>16</sup> A.K. Mohanty,<sup>25</sup> A. Mohapatra,<sup>24</sup> J. Molnar,<sup>11</sup> S. Muhammad,<sup>20</sup> S. Mukhopadhyay,<sup>21</sup> M. Naimuddin,<sup>12</sup> S. Nuzzo,<sup>2</sup> E. Oliveri,<sup>18</sup> L.M. Pant,<sup>25</sup> P. Paolucci,<sup>26</sup> I. Park,<sup>34</sup> G. Passeggio,<sup>26</sup> B. Pavlov,<sup>31</sup> B. Philipps,<sup>1</sup> D. Piccolo,<sup>15</sup> H. Postema,<sup>18</sup> A. Puig-Baranac,<sup>18</sup> A. Radi,<sup>8</sup> R. Radogna,<sup>2</sup> G. Raffone,<sup>15</sup> A. Ranieri,<sup>2</sup> G. Rashevski,<sup>30</sup> C. Riccardi,<sup>27</sup> M. Rodozov,<sup>30</sup> A. Rodrigues,<sup>18</sup> L. Ropelewski,<sup>18</sup> S. RoyChowdhury,<sup>21</sup> G. Ryu,<sup>34</sup> M.S. Ryu,<sup>34</sup> A. Safonov,<sup>10</sup> S. Salva,<sup>19</sup> G. Saviano,<sup>15</sup> A. Sharma,<sup>18</sup> R. Sharma,<sup>12</sup> M. Shopova,<sup>30</sup> J. Sturdy,<sup>13</sup> G. Sultanov,<sup>30</sup> S.K. Swain,<sup>6</sup> Z. Szillasi,<sup>11</sup> J. Talvitie,<sup>22</sup> A. Tatarinov,<sup>10</sup> T. Tuuva,<sup>22</sup> M. Tytgat,<sup>19</sup> I. Vai,<sup>27</sup> M. Van Stenis,<sup>18</sup> R. Venditti,<sup>2</sup> E. Verhagen,<sup>5</sup> P. Verwilligen,<sup>2</sup> P. Vitulo,<sup>27</sup> S. Volkov,<sup>17</sup> A. Vorobyev,<sup>17</sup> D. Wang,<sup>3</sup> M. Wang,<sup>3</sup> U. Yang,<sup>33</sup> Y. Yang,<sup>5</sup> R. Yonamine,<sup>5</sup> N. Zaganidis,<sup>19</sup> F. Zenoni<sup>5</sup> and A. Zhang<sup>24</sup> on behalf of CMS muon collaboration

<sup>1</sup>RWTH Aachen University, III Physikalisches Institut A, Aachen, Germany

<sup>2</sup>Politecnico di Bari, University of Bari and INFN Bari, Bari, Italy

<sup>3</sup>Peking University, Beijing, China

<sup>4</sup>University and INFN Bologna, Bologna, Italy

\*Corresponding author.



- <sup>5</sup>*Universite Libre de Bruxelles, Brussels, Belgium*
- <sup>6</sup>*National institute of Science Education and Research, Bhubaneswar*
- <sup>7</sup>*Institute for Particle and Nuclear Physics, Wigner Research Centre for Physics, Hungarian Academy of Sciences, Budapest, Hungary*
- <sup>8</sup>*Academy of Scientific Research and Technology, ENHEP, Cairo, Egypt*
- <sup>9</sup>*Helwan University & CTP, Cairo, Egypt*
- <sup>10</sup>*Texas A&M University, College Station, U.S.A.*
- <sup>11</sup>*Institute for Nuclear Research of the Hungarian Academy of Sciences (ATOMKI), Debrecen, Hungary*
- <sup>12</sup>*University of Delhi, Delhi, India*
- <sup>13</sup>*Wayne State University, Detroit, U.S.A*
- <sup>14</sup>*Texas A&M University at Qatar, Doha, Qatar*
- <sup>15</sup>*Laboratori Nazionali di Frascati - INFN, Frascati, Italy*
- <sup>16</sup>*University of Florida, Gainesville, U.S.A.*
- <sup>17</sup>*Petersburg Nuclear Physics institute, Gatchina, Russia*
- <sup>18</sup>*CERN, Geneva, Switzerland*
- <sup>19</sup>*Ghent University, Dept. of Physics and Astronomy, Ghent, Belgium*
- <sup>20</sup>*National Centre for Physics, Quaid-i-Azam University Campus, Islamabad Pakistan*
- <sup>21</sup>*Saha institute of Nuclear Physics, Kolkata, India*
- <sup>22</sup>*Lappeenranta University of Technology, Lappeenranta, Finland*
- <sup>23</sup>*University of California, Los Angeles, U.S.A.*
- <sup>24</sup>*Florida institute of Technology, Melbourne, U.S.A.*
- <sup>25</sup>*Bhabha Atomic Research Centre, Mumbai, India*
- <sup>26</sup>*INFN Napoli, Napoli, Italy*
- <sup>27</sup>*INFN Pavia and University of Pavia, Pavia, Italy*
- <sup>28</sup>*INFN Sezione di Pisa, Pisa, Italy*
- <sup>29</sup>*IRFU CEA-Saclay, Saclay, France*
- <sup>30</sup>*Institute for Nuclear Research and Nuclear Energy, Sofia, Bulgaria*
- <sup>31</sup>*Sofia University, Sofia, Bulgaria*
- <sup>32</sup>*Korea University, Seoul, Korea*
- <sup>33</sup>*Seoul National University, Seoul, Korea*
- <sup>34</sup>*University of Seoul, Seoul, Korea*
- <sup>35</sup>*Institut Pluridisciplinaire - Hubert Curien (IPHC), Strasbourg, France*

*E-mail:* [waqar@cern.ch](mailto:waqar@cern.ch)

**ABSTRACT:** The CMS experiment at LHC will upgrade its forward muon spectrometer by incorporating Triple-GEM detectors. This upgrade referred to as GEM Endcap (GE1/1), consists of adding two back-to-back Triple-GEM detectors in front of the existing Cathode Strip Chambers (CSC) in the innermost ring of the endcap muon spectrometer. Before the full installation of 144 detectors in 2019–2020, CMS will first install ten single chamber prototypes during the early 2017. This pre-installation is referred as the slice test. These ten detectors will be read-out by VFAT2 chips [1]. On-detector there is also a FPGA mezzanine card which sends VFAT2 data optically to the  $\mu$ TCA back-end electronics. The correct and safe operation of the GEM system requires

a sophisticated and powerful online Detector Control System, able to monitor and control many heterogeneous hardware devices. The DCS system developed for the slice test has been tested with CMS Triple-GEM detectors in the laboratory. In this paper we describe the newly developed DCS system and present the first results obtained in the GEM assembly and quality assurance laboratory.

**KEYWORDS:** Detector control systems (detector and experiment monitoring and slow-control systems, architecture, hardware, algorithms, databases); Front-end electronics for detector readout

---

## Contents

<b>1</b>	<b>Introduction</b>	<b>1</b>
1.1	The GEM DCS hardware architecture	2
1.2	GEM chambers readout electronics	2
1.3	Proposed plan of HV/LV setup for slice test	3
<b>2</b>	<b>On-detector sensors</b>	<b>4</b>
2.1	Radiation monitor sensors	4
2.2	Fiber Bragg Grating sensors	5
<b>3</b>	<b>GEM Detector Control System</b>	<b>5</b>
3.1	Slice test and LS2 system requirements	5
3.2	GEM system hierarchy	7
3.3	High level control and monitoring via Finite State Machine	7
3.4	Archiving and trending	9
3.5	GEM chamber testing software	9
3.6	GEM assembly and quality assurance laboratory operations	11
<b>4</b>	<b>Conclusion</b>	<b>11</b>

---

## 1 Introduction

The Compact Muon Solenoid (CMS) is a general-purpose detector at the Large Hadron Collider (LHC). It has a broad physics programme ranging from studying the Standard Model (namely Higgs boson) to searching for extra dimensions, and particles that could make dark matter. The Detector Control System (DCS) is responsible for monitoring of the slow control data of the experiments such as information from gas and cooling systems, environmental sensors (humidity, pressure and temperature) and radiation detectors [2]. Furthermore, the DCS controls all Low Voltage (LV) and High Voltage (HV) power supply channels, which are required to drive on-detectors electronics. The DCS front-end panel also shows the current status of each chamber like ON, OFF or Trip condition. All important parameters are recorded and archived in the condition database. The configuration information, such as nominal channel voltages and current limits can be stored in a configuration database, from where they can be applied to the running system on demand. During data taking mode, when any parameter changes its value, DCS stores and updates each selected parameter in the condition database. The DCS system issues early warnings about abnormal conditions and subsequently triggers the safety switches in order to protect the detector and its electronics from severe damages.

The CMS DCS is based on commercial WinCC Open Architecture (WinCC-OA) Supervisory Control and Data Acquisition (SCADA) [3] and toolkit from the Joint Control Project (JCOP).

Moreover, the JCOP framework developed at CERN is used to extend WinCC-OA toolkit that is useful in the high energy physics domain. The CMS DCS consists of a central supervisor that communicates with the DCS of each sub-detector. In this way, separate sub-detector control systems are developed independently and they will be integrated to the centrally defined global CMS DCS.

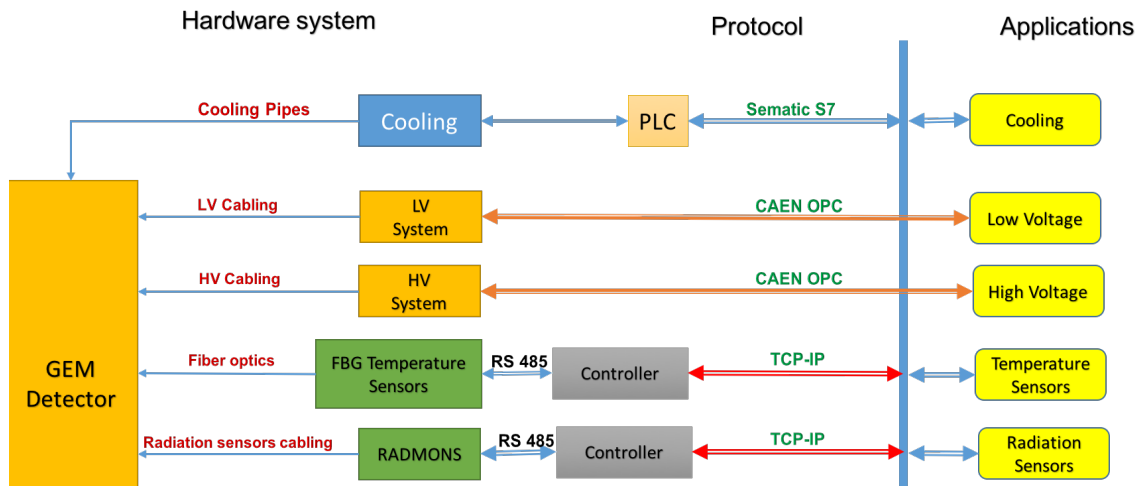

**Figure 1.** GEM Detector Control System architecture.

### 1.1 The GEM DCS hardware architecture

During the second LHC Long Shutdown (LS2), the CMS experiment will upgrade its forward muon spectrometer by adding a new sub-detector made of Triple-GEM detectors. This CMS upgrade is known as GE1/1 project and requires installation of 144 Triple-GEM detectors at  $1.5 < |\eta| < 2.2$  region. For this new sub-detector a new GEM DCS system has to be developed. GEM DCS model has different logical groups according to geographical sub-divisions of the detector and hardware system. The GEM DCS hardware has been divided into several sub-systems like HV, LV, environmental sensors (humidity, temperature, and pressure), gas and cooling systems as shown in figure 1.

This paper focusses on the design of software applications for the control and monitoring of the HV/LV systems and environmental parameters. Furthermore, the current development is focused on the so-called Slice Test, which includes the installation of 10 Triple-GEM detectors in the CMS forward muon spectrometer, by 2017.

### 1.2 GEM chambers readout electronics

One CMS GEM chamber has a segmentation of three in  $\phi$  and eight in  $\eta$ , creating a maximum of 24 individual detector segments. Each of these segments is further divided into 128 strips and readout by one of 128 channels VFAT2 [4] ASIC. There is one VFAT2 chip per GEM segment which is used to readout charge deposited on each GEM channel. As shown in figure 2, each VFAT transmits its binary data to the Optohybrid (OH), an FPGA mezzanine located on the wide end of the GEM detector through the GEM Electronics Board (GEB). This data is transmitted optically via OH to the  $\mu$ TCA-based off-detector electronics located in the counting room [5]. Power is delivered to

the GEM chamber by electrical cables. Local DC/DC regulators stabilize the voltage to the levels required by on-detector electronics. The off-detector electronics has an interface and driver unit providing interface to the CMS trigger, DAQ, DCS and Timing, Trigger and Control (TTC) systems as well as allowing integration to the existing Pattern Comparator (PAC) trigger.

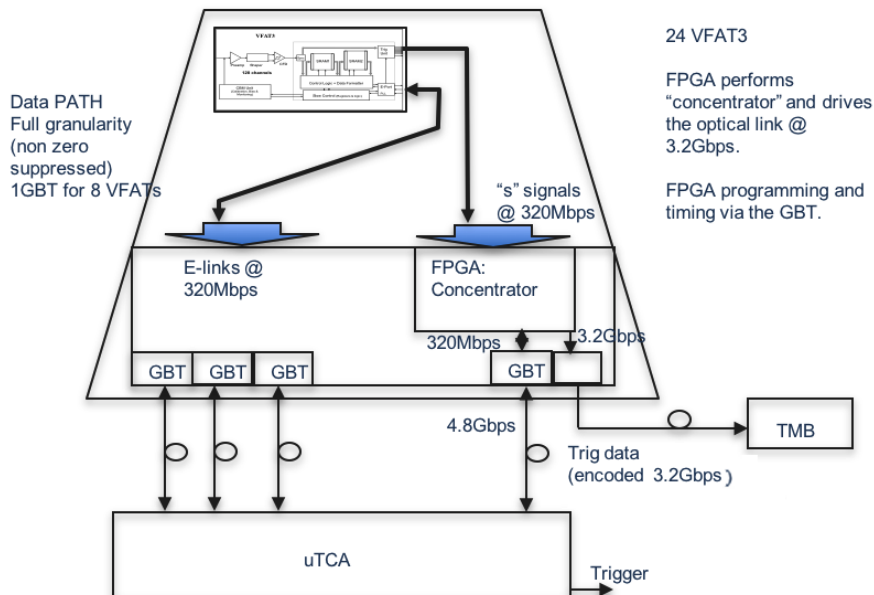

**Figure 2.** CMS Triple GEM chamber readout electronics full chain with  $\mu$ TCA

### 1.3 Proposed plan of HV/LV setup for slice test

The pre-installation of 4 super-chambers (pairs of Triple-GEM chambers combined together to form super-chambers) is called slice test of the GEM project. A single-channel HV powering scheme, based on a HV resistive divider circuit on the chamber is proposed. One more super-chamber is planned to be installed with a special kind of HV power supply board (CAEN A1515TG/A1515QG). This module was designed by CAEN specially for the CMS GEM project. This new module offers multi-channel HV powering with the possibility to switch all stacked channels following a programmed sequence. This configuration permits to avoid any possible issue related to the detector discharge. It also allows the possibility to fine tune the voltage on each GEM electrode easily.

A CAEN SY4527 mainframe is equipped with 16 CAEN A1515TG/A1515QG boards which is capable to power-up 32 detectors simultaneously. The maximum current available on each channel allows managing the high segmentation of these detectors in the best possible way. In addition, the CAEN A1515TG with its 100 pA current monitoring resolution allows the monitoring of ion back-flow currents and enables real time detector diagnostic [6]. The CAEN A1515TG power supply allows to set the voltage on the drift and automatically set next three voltages on each GEM foil according to the required potential and permits a precise measurement of each GEM foil current.

For this new CAEN board, the software driver is being developed to allow establishing communication with the hardware and the GEM DCS. In addition, a LV power system is needed to power the various on-detector electronics components mainly the VFAT2, GEM electronics Board,

**Table 1.** Low voltages power consumption of GE1/1 detectors using VFAT2 chips.

	Voltage	Consumption for single chamber	Consumption for super-chamber
VFAT2	3.3 V	8A	16A
Opto-hybrid	4 V	6A	12A
Opto-hybrid	1.7 V	4A	8A

optohybrid and its FPGA. The LV requirements are shown in table 1. The LV power system of GE1/1 is based on CAEN EASY 3000 crates and CAEN A1527 power supplies.

## 2 On-detector sensors

### 2.1 Radiation monitor sensors

In the LHC experiments, the proton-proton collision creates different kind of radiation that are mainly composed of neutrons, photons and charged hadrons. In the GE 1/1 region, the neutron flux reaches up to  $100 \text{ KHz cm}^{-2}$  and it is the closest part to the beam line ( $\eta \approx 2.2$ ). Although the detector material and the electronics components have been tested for the expected radiation level in GE 1/1, it is important to monitor the radiation level in the area of the experiment.

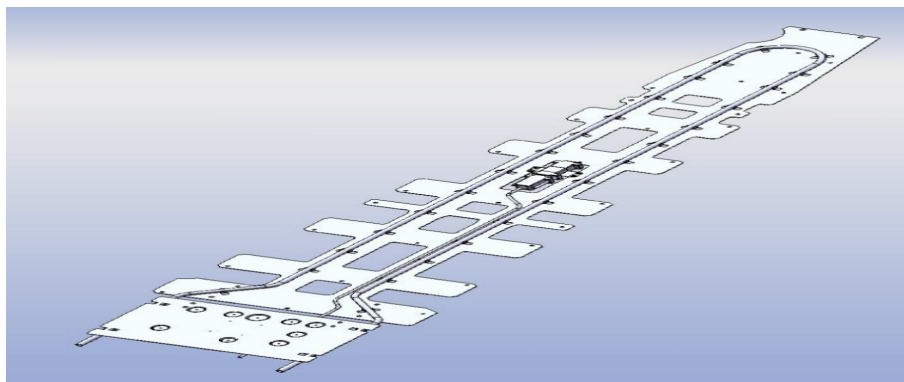
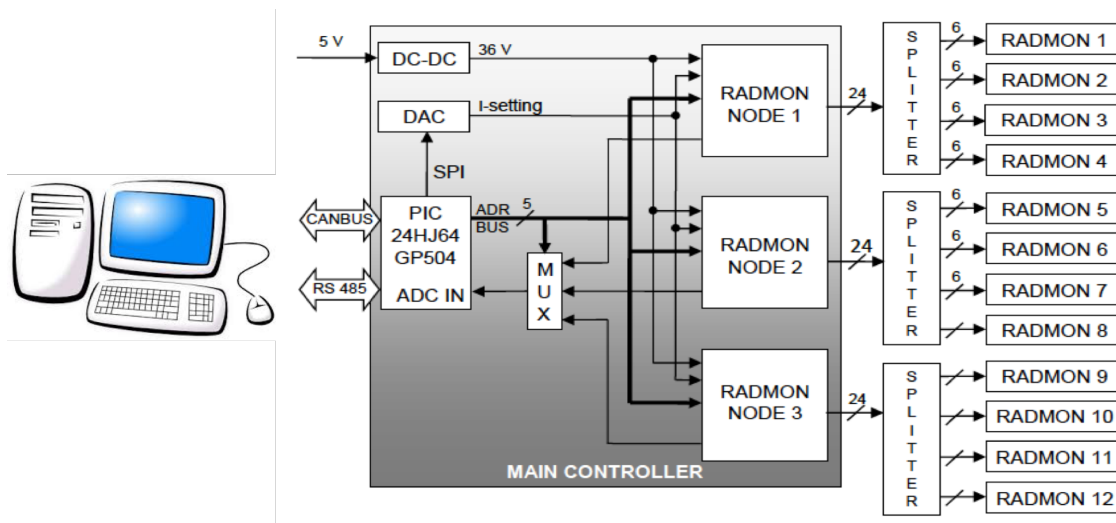

**Figure 3.** A RADMON Box located at the center of the CMS GEM cooling circuit.

A universal dosimetry device called Radiation Monitoring (RADMON) has been developed and produced at CERN for similar investigations [7]. RADMON is based on p-channel MOS transistors that are used to measure the ionizing energy deposition and thereby causing the creation of electron-hole pairs in the material. The dosimeters operate by positive charge build-up on the gate oxide ( $\text{SiO}_2$ ) layer of the transistor. The positive charge trapped for long time at room temperature leads to a shift of the transistor gate voltage that is proportional to the radiation dose and is measured by the RADMON sensor. In GE 1/1, RADMON is installed on the GEM cooling plate as shown in figure 3 to monitor the radiation dose at high  $\eta$  region.

The readout system uses a master-slave message based protocol. The main controller addresses one of several connected RADMON sensors at a time. The address of each sensor controller is set





**Figure 4.** Block diagram of the RADMON control and read-out system.

by onboard micro-switches [8] as shown in figure 4. The main controller connects to the PC over a CANBUS or RS-485 interface and sends the data to the device that converts the serial data into the TCP/IP port. The GEM DCS, communicates with the RADMON using TCP/IP protocol.

## 2.2 Fiber Bragg Grating sensors

The GEM collaboration intends to install Fiber Bragg Grating (FBG) sensors on the GEM super-chambers for monitoring the temperature. An FBG is a type of distributed Bragg reflector constructed in a short segment of optical fiber that reflects particular wavelengths of light and transmits all others [9]. The sensor is made by creating a periodic variation in the refractive index of the fiber core, which generates a wavelength-specific dielectric mirror. FBG sensors have been mainly used in high energy physics as a high precision positioning and alignment of the detector on the CMS disk. The temperature sensitivity of FBG (relative elongation with respect to the initial position) is 0.1 degree.

Final sketch mounting of the FBG sensors is shown in figure 5. In total 5 FBG sensors will be installed on one chamber with 2 FBG sensors installed on the readout board, 2 on the GEB and 1 on the cooling plate. So, 10 FBG sensors will be installed on one super-chamber. All FBG sensors of one super-chamber will be connected in series. The FBG sensors will be connected to an integrator interfaced to a standard PC through TCP/IP, allowing their remote control. In GEM DCS we will use DIM protocol [10] on CMS secure network to communicate with FBG sensors.

## 3 GEM Detector Control System

### 3.1 Slice test and LS2 system requirements

A first test system is implemented in the GEM assembly and in quality assurance laboratory for cosmic ray chamber characterisation. In the laboratory, it is needed to control scintillators (cosmic test stand), GEM chambers HV/LV and finally store information in the GEM database. The HV

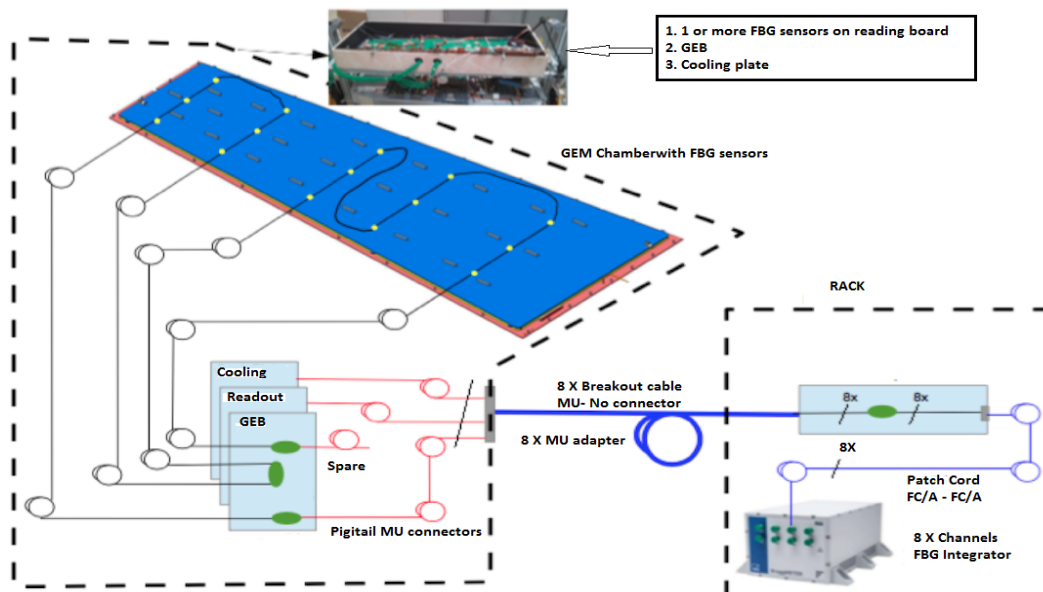

**Figure 5.** Sketch of mounting the Fiber Bragg Grating on the GEM chambers.

scanning of the GEM chambers is one of the main procedures controlled through the DCS system. As mentioned in section 1.3, during the slice test two different HV powering schemes will be used, the first one using a resistor divider and a second one using seven independent voltage channels using multi-channel power supplies.

In slice test, 4 super-chambers will be equipped with the resistor divider and these will get power from a CAEN A1527 HV mainframe power supply. In total, eight channels of CAEN A1526N HV modules are considered enough to power the 4 super-chambers. The fifth super-chamber will employ the new CAEN 1515TG/QG module (see section 1.3).

For the LV powering, each GEM chamber requires three power channels as listed in table 1. The LV power will be delivered by the CAEN A3016 modules housed inside the CAEN 3000 crates located in the experimental hall. In total 30 channels are required to power the 5 slice test super-chambers.

The design of the GE1/1 cooling system is based on the calculations of the total power consumption of one super-chamber (156 W) and it will cover each heat source on the detector side, i.e. the VFAT boards (8 W), the optohybrid (48 W) and the HV divider (100 W). The GE1/1 chambers will use the cooling loops that were employed earlier for Resistive Plate Chamber Endcap (RE1/1). The cooling and gas systems are instead developed centrally by CMS and all information is monitored and shared through the Central DCS using the Data Interchange Protocol (DIP) middleware.

The GEM gas system will re-use the pressure controllers, the pre-distribution system and the final distribution racks already commissioned for the RE1/1 gas system. The GE1/1 gas system is partially using the existing gas infrastructure, in particular the previously installed copper pipes which run between the GE1/1 installation zones and the gas distribution rack located on the experimental hall. For slice test, we will use only five supplies and five return flow cells from the rack. As shown in figure 6 all gas control panels for GE1/1 are tested using DIP in CMS secure network.

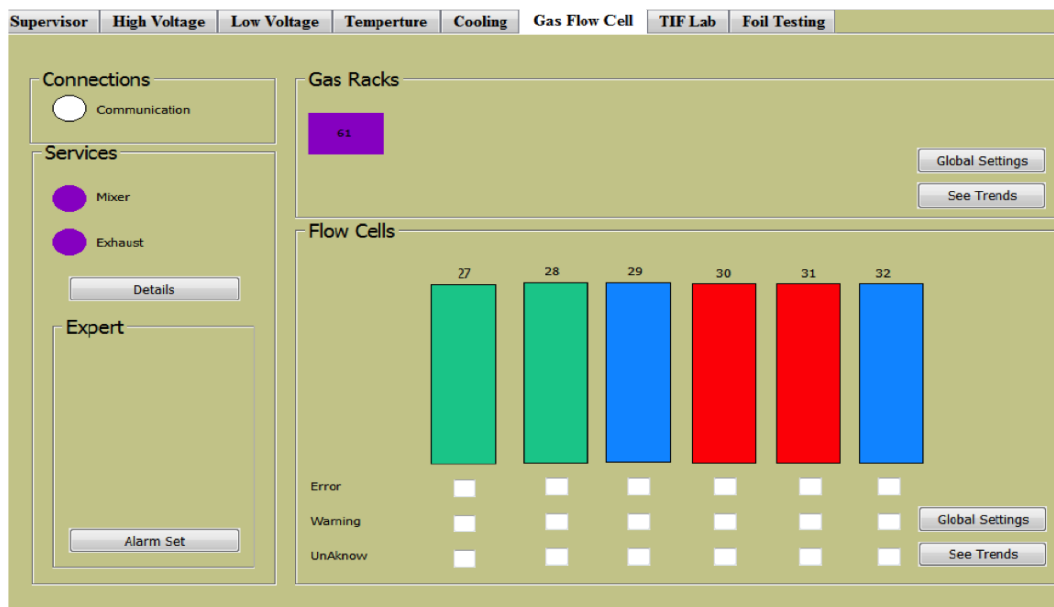

**Figure 6.** GE1/1 Gas system implemented in DCS using DIP protocol.

For the complete installation, during the proposed Long Shutdown-2 (LS2) it is envisaged that 72 super-chambers on first endcap will be installed. Depending on the result from the slice test, the resistor divider or the multichannel HV power scheme will be chosen in 2017. In addition, a decision will also be taken regarding the number of LV channels used for on-detector electronics per super-chambers. Detail investigation on the LV channel besides DC/DC circuits for on-detectors electronics is under investigation.

### 3.2 GEM system hierarchy

The detector controls are organized in a tree-like Finite State Machine (FSM) node hierarchy representing the logical structure of the detector and division into sub-components. These sub-detector DCS subsystems control all the individual detector services and electronics, such as the power supplies, both commercial and custom made, and all the auxiliary systems required for the detector operation as shown in figure 7. The different branches describe the GEM system from geographical and hardware points of view. All commands go down the hierarchy while information and error messages are reported upward.

To implement the propagation of states and commands in the GEM DCS hierarchy of objects, the JCOP framework FSM toolkit is used to model each node of the hierarchy of objects with a defined number of states and actions. Transition between the states can occur based on the execution of an action or the change of state of objects lower down in the hierarchy.

### 3.3 High level control and monitoring via Finite State Machine

The GEM FSM offers a user friendly interface for non-expert operators to control the full operation of the detector. The top nodes have the main states of ON, OFF, STANDBY, and Error. The available commands are ON, OFF or STANDBY as shown in figure 8.

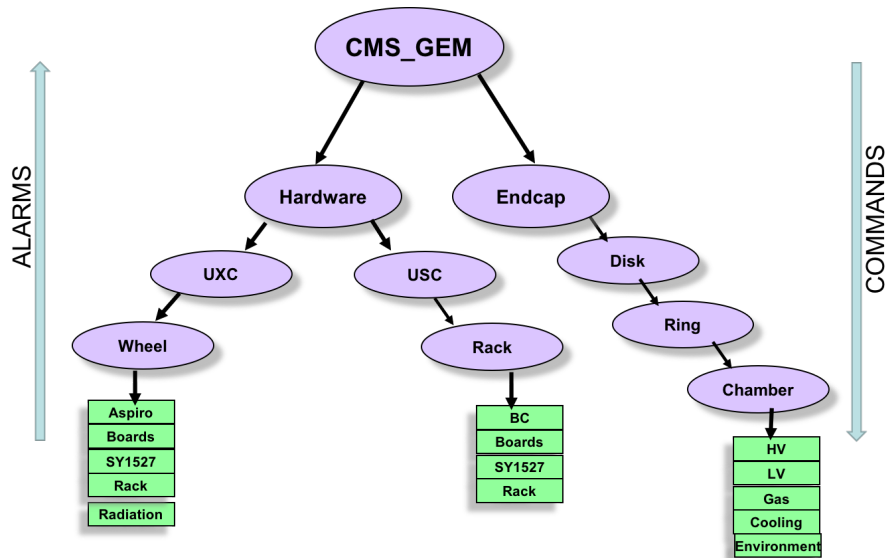

Figure 7. GEM DCS hierarchy structure view, commands go down, and error messages are reported upward.

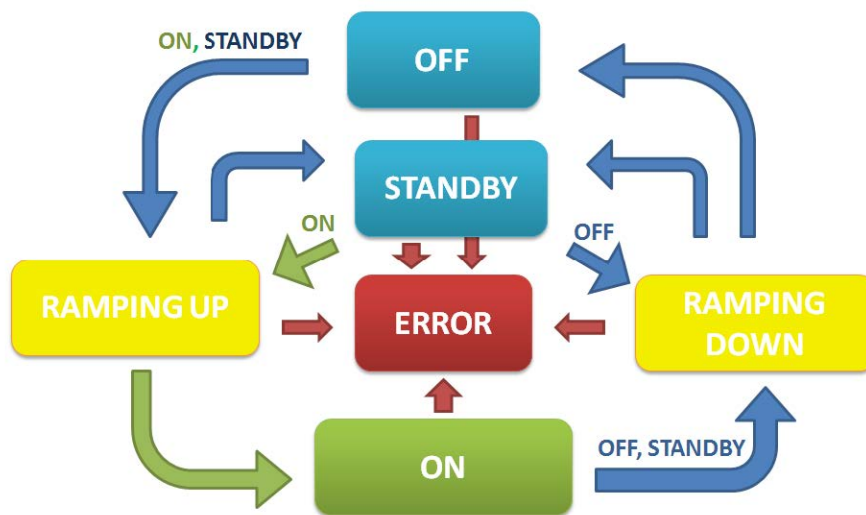
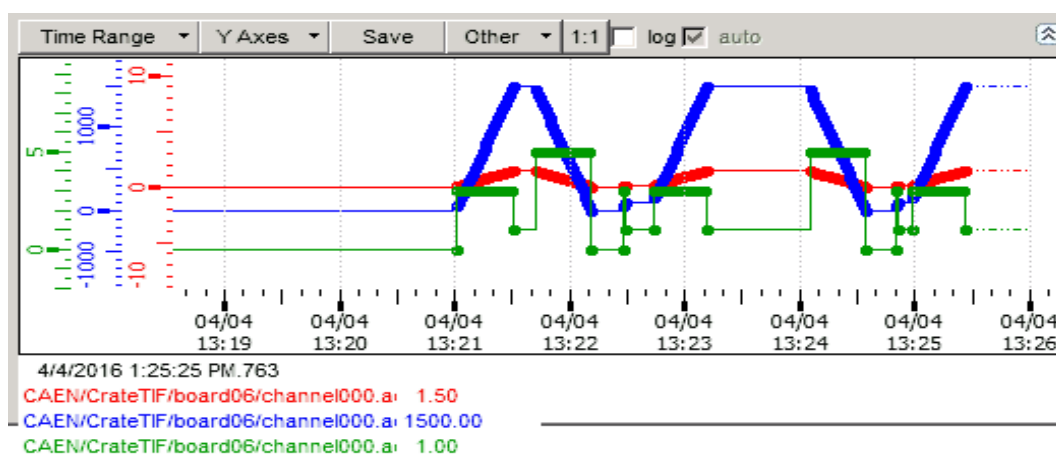

Figure 8. GEM Finite State Machine (FSM).

The use of these states and commands ensures compatibility with the central CMS DCS controls interface. The STANDBY state means that the detectors are in a partially powered state, which will be safe for the detector hardware in case of conditions such as unstable LHC beam or CMS magnet ramping. Specifically for the GEM DCS, the STANDBY states imply that LV is ON and HV is at an intermediate voltage lower than the nominal value for physics operation. At lower levels in the hierarchy, more detailed states and actions can be implemented as required. Examples are the ramping states, RAMPING UP and RAMPING DOWN, that are used when the HV channels are in a transient state.

### 3.4 Archiving and trending

The structural information of the sub-elements, their interconnection, installation and configuration information for hardware and software components are initially stored in the WinCC-OA internal database. Afterwards the information is stored in an external configuration database. For the present control system, the configuration database has been used to store the structural layout of the hardware devices and their physical and logical addresses. In addition, the system configuration values for ON and STANDBY states have also been archived here. The configuration database photographs the system in its initial conditions. The final developments and possible changes from the starting point are recorded in a different database called the condition database.

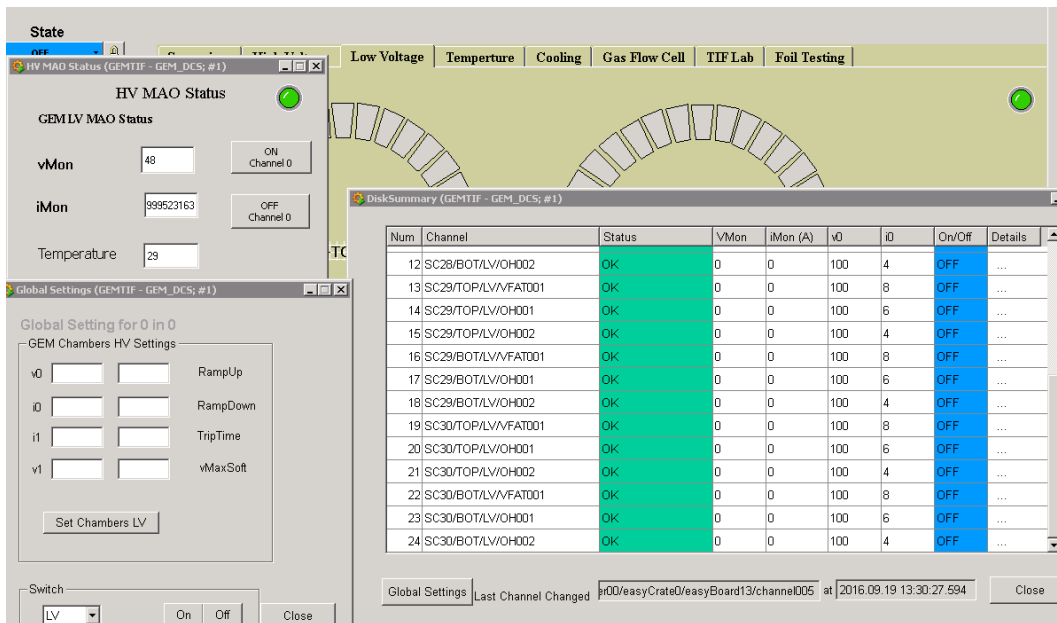

**Figure 9.** Representation of detector's data [GEM voltage (blue), current (red), and states (green)] over certain period of time.

In general, the condition database will hold all parameters for the run of the detector and its operational parameters. It keeps record of malfunctioning parts, the information inherent in alignment and calibration and environmental parameters. In the WinCC-OA trending function, develop trends for every chamber. In WinCC-OA the trending class allows evaluate the parameters stored in the condition database over certain period of time, as shown in figure 9. The data can be extracted by selecting the option time range from the trend toolbar. The graphical interface builder of WinCC-OA is used to create a GUI for the user that visualizes all relevant information system parameters in the DCS as shown in figure 10. To fulfil the requirements for operation, approximately more than fifty panels have been designed. It provides a visual summary of the status of a selected node and the possibility to monitor and modify configuration parameters, depending on the user privileges. The GUI allows a complete control of the entire GEM system, therefore, access control is implemented. The authorization panels ensure that only people with sufficient rights can perform operations on the system.

### 3.5 GEM chamber testing software

For the GEM detector assembly and quality control tests, that have to be performed in a dedicated laboratory at CERN, a special panel has been developed. As illustrated in figure 11, it allows to perform GEM super-chamber HV scans. The control panel monitors the GEM detectors LV as



**Figure 10.** Layout of GEM detectors panels.

well as the voltage applied to the scintillators. The lower right corner in figure 11 represents the graphical representation of GEM cosmic bench used for quality control test of GEM detectors.

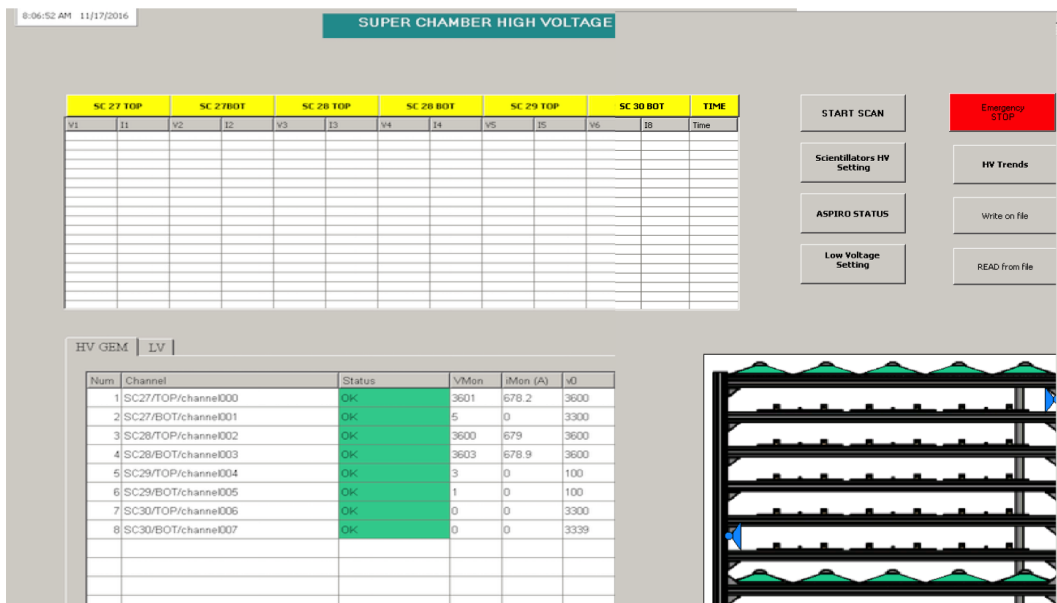

**Figure 11.** Panel for the GEM HV scan and to control the scintillators on the cosmic bench for the GEM detector quality control tests.

The panel allows to run through a pre-configured voltage and current setting sequence, with a specific period of time at each setting to allow a stable operation of the detector. An emergency button is also available to stop the HV scanning in case of any problem detected during the run.

### 3.6 GEM assembly and quality assurance laboratory operations

We adopted the complete quality assurance procedures during GEM assembly and implemented HV, LV and alert system in the DCS software. Five super-chambers have been tested with cosmic rays for two months. After implementation of GEM DCS panel, it can host ten super-chambers simultaneously with this cosmic stand. Also simulated parameters validated with actual hardware parameters.

## 4 Conclusion

This paper presents the current status of DCS system for the new CMS GEM detectors. The Finite State Machine of GEM DCS is ready and tested in the lab. The HV/LV control system has been implemented and tested using CAEN simulator and validated using actual system. The radiation dose and temperature monitoring is also implemented in GEM DCS. The GEM DCS proved to be quite flexible and user friendly. GEM DCS has been successfully deployed in the laboratory for GEM assembly and quality assurance. Worked on the gas panels testing and their deployment in GEM DCS system. Design for cooling system panels is in progress. After test and verification of the whole system, it will be integrated to the final central CMS DCS system.

## Acknowledgments

We gratefully acknowledge support from FRS-FNRS (Belgium), FWO-Flanders (Belgium), BSF-MES (Bulgaria), BMBF (Germany), DAE (India), DST (India), INFN (Italy), NRF (Korea), QNRF (Qatar), and DOE (U.S.A.) and specially my colleague Oliver Holme.

## References

- [1] P. Aspell et al., *VFAT2: A front-end “system on chip” providing fast trigger information, digitized data storage and formatting for the charge sensitive readout of multi-channel silicon and gas particle detectors*, *IEEE Nucl. Sci. Symp. Conf. Rec.* (2008) doi:[10.1109/NSSMIC.2008.4774696](https://doi.org/10.1109/NSSMIC.2008.4774696).
- [2] G. Bauer et al., *Status of the CMS Detector Control System*, [CMS-CR-2012-129](https://cds.cern.ch/record/129129) (2012).
- [3] SCADA System SIMATIC WinCC Open Architecture, <http://w3.siemens.com/mcms/human-machine-interface/en/visualization-software/simatic-wincc-open-architecture/pages/default.aspx>.
- [4] A Colaleo et al., *CMS Technical Design Report for the Muon Endcap GEM Upgrade*, [CERN-LHCC-2015-012](https://cds.cern.ch/record/1512012) CMS-TDR-013 (2015).
- [5] PICMG, Open Modular Computing Standard, <https://www.picmg.org/openstandards/microtca>.
- [6] <http://www.caen.it/csite/CaenProd.jsp?parent=20&idmod=960>.
- [7] F. Ravotti et al., *Conception of an Integrated Sensor for the Radiation Monitoring of the CMS Experiment at the Large Hadron Collider*, [CERN-PH-EP-2004-004](https://cds.cern.ch/record/554444) (2004) [*IEEE Trans. Nucl. Sci.* **51** (2004) 3642].
- [8] F. Ravotti et al., *Development and Characterisation of Radiation Monitoring Sensors for the High Energy Physics Experiments of the CERN LHC Accelerator*, Ph.D. Thesis, Montpellier University, Geneva, Switzerland (2006), presented on 17 November 2006.
- [9] L. Benussi, *Optical system for the quality assessment Of MPGD foil/mesh mechanical tensioning*, [AIDA-2020-MS1](https://cds.cern.ch/record/2200000) (2016).
- [10] <https://wikis.web.cern.ch/wikis/display/EN/DIP+and+DIM>.