



Premiere Publications from The Triological Society

Read all three of our prestigious publications, each offering high-quality content to keep you informed with the latest developments in the field.



THE Laryngoscope FOUNDED IN 1896

Editor-in-Chief: Michael G. Stewart, MD, MPH

The leading source for information in head and neck disorders.

Laryngoscope.com

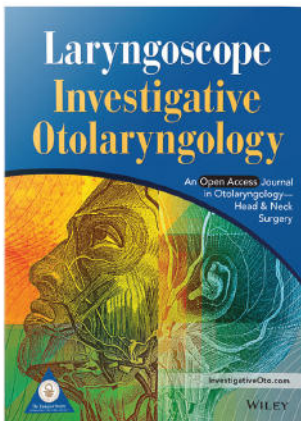

Laryngoscope Investigative Otolaryngology Open Access

Editor-in-Chief: D. Bradley Welling, MD, PhD, FACS

Rapid dissemination of the science and practice of otolaryngology-head and neck surgery.

InvestigativeOto.com

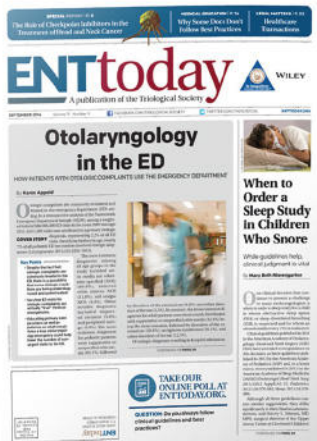

ENTtoday A publication of the Triological Society

Editor-in-Chief: Alexander Chiu, MD





Must-have timely information that Otolaryngologist-head and neck surgeons can use in daily practice.

Enttoday.org

WILEY

ORIGINAL RESEARCH

Diagnosing nasal obstruction and its common causes using the nasal acoustic device: A pilot study

Chia-Hung Li MRes^{1†} | Anika Kaura MA(Cantab), MBBS, MRCS, DOHNS^{2,3†}  |
 Calvin Tan BSc^{1,4} | Katherine L. Whitcroft BSc, MBChB^{2,3}  |
 Terence S. Leung PhD¹  | Peter Andrews MD(Res), FRCS^{2,3} 

¹Department of Medical Physics and Biomedical Engineering, University College London, London, UK

²Department of Rhinology and Facial Plastic Surgery, Royal National Throat, Nose and Ear Hospital, London, UK

³UCL Ear Institute, University College London, London, UK

⁴UCL Medical School, Faculty of Medical Sciences, University College London, London, UK

Correspondence

Anika Kaura, UCL Ear Institute, 332 Grays Inn Road, London WC1X 8EE, UK.
 Email: anika.kaura.19@ucl.ac.uk

Funding information

Engineering and Physical Sciences Research Council

Abstract

Objectives: There is a need to develop a medical device which can accurately measure normal and abnormal nasal breathing which the patient can better understand in addition to being able to diagnose the cause for their nasal obstruction.

The aim is to evaluate the accuracy of the nasal acoustic device (NAD) in diagnosing the common causes for nasal obstruction and diagnosing normal and abnormal (nasal obstruction) nasal breathing.

Methods: This pilot study recruited 27 patients with allergic rhinitis (AR), chronic rhinosinusitis (CRS), and a deviated nasal septum (DNS) which represents the common causes for NO and 26 controls (with normal nasal breathing). Nasal breathing sounds were recorded by the NAD akin to two small stethoscopes placed over the left and right nasal ala. The novel outcome metrics for the NAD include inspiratory nasal acoustic score (INA) score, expiratory nasal acoustic (ENA) score and the inspiratory nasal obstruction balance index (NOBI). The change in acoustic score following decongestant is key in this diagnostic process.

Results: Pre-decongestant ENA score was used to detect the presence of nasal obstruction in patients compared to controls, with a sensitivity of 0.81 (95% CI: 0.66-0.96) and a specificity of 0.77 (0.54-1.00). Post-decongestant percentage change in INA score was used to identify the presence of AR or CRS, with a sensitivity of 0.87 (0.69-1.00) and specificity of 0.72 (0.55-0.89) for AR; and a sensitivity of 0.92 (0.75-1.00) and specificity of 0.69 (0.52-0.86) for CRS. Post-decongestant inspiratory NOBI was used to identify DNS, with a sensitivity of 0.77 (0.59-0.95) and specificity of 0.94 (0.82-1.00).

[†]Chia-Hung Li and Anika Kaura are joint first authors and contributed equally to this work.

Conclusion: We have demonstrated that the NAD can help distinguish between normal and abnormal nasal breathing and help diagnose AR, CRS, and DNS. Such a device has not been invented and could revolutionize COVID-19 recovery telemedicine.

Level of Evidence: Diagnostic accuracy study—Level III.

KEYWORDS

allergic rhinitis, chronic rhinosinusitis, deviated nasal septum, nasal inspiratory peak flow, nasal obstruction

1 | INTRODUCTION

Nasal obstruction is a common condition affecting over 30% of the adult population¹ and yet patients in the United Kingdom remain dissatisfied with their treatment.² There is a need to develop a medical device which can accurately measure nasal obstruction and distinguish between normal and abnormal nasal breathing which the patient can better understand, according to our patient end user questionnaire.² In addition, there is a need to develop a medical device which could help diagnose the cause of their nasal obstruction and enable more streamlined treatments, revolutionize treatment pathways in primary care and reduce costly secondary care referrals.³ Importantly this would help improve the patient's understanding of their diagnosis and treatment, and reduce patient dissatisfaction.

Nasal obstruction can be defined as a feeling of discomfort due to inadequate nasal airflow. The commonest nasal diseases which cause nasal obstruction include two inflammatory disorders: allergic rhinitis (AR) and chronic rhinosinusitis (CRS) with the estimated prevalence rate in Europe being 25% for AR⁴ and 11% for CRS.⁵ Though less common, nasal obstruction can also be caused by a structural alteration, such as a deviated nasal septum (DNS). Overall, nasal obstruction is one of the commonest ear, nose, and throat (ENT) presentations in primary care and one of the commonest reasons for secondary care ENT referrals.^{6,7} For example, in the United Kingdom there were 5.2 million visits to a general practitioner (GP) for nasal obstruction annually, at a cost of £48.91 per visit (total £254 million).⁸

Current medical devices available on the market can only measure nasal airflow and cross sectional area of the internal nose which include NIPF, acoustic rhinometry and rhinomanometry.⁹⁻¹³ NIPF has been most widely adopted in the United Kingdom as it is easy to use and cheap and has also been validated for unilateral (uNIPF) measurement, by occluding one nostril at a time.¹⁴ However, NIPF cannot diagnose the cause of nasal blockage however changes in NIPF following decongestant can help in distinguishing the presence of decongestible nasal obstruction.¹⁵

There is also an increasing drive from NHS England to streamline diagnostics in primary care and reduce secondary care referrals for ENT conditions which could be easily diagnosed and managed within primary care if the technology is available.¹⁶ This would reduce the demand on costly secondary care services and improve cost

efficiency. However, up to now a diagnostic device has not been invented. The current COVID-19 pandemic has further highlighted this unmet need by halting all elective out-patient services globally resulting in a significant backlog of nonurgent rhinology referrals. In the United Kingdom, nasal endoscopy is only considered a potential aerosol generating procedure (AGP) and guidelines are in place to ensure its safe use during the recovery phase.^{17,18,19} Equally, the current airway objective tools could also be considered potential AGPs with an increased risk of virus transmission. NIPF requires both maximal exhalation and inhalation, whereas acoustic rhinometry and rhinomanometry involve instrumentation within the nose.

Currently, based on our ENT surgeon and patient end user questionnaires, patients with persistent nasal obstruction can wait up to 5 years before they are diagnosed and treated in secondary care.²⁰ According to our GP questionnaire there is a need to improve nasal obstruction patient pathways within primary care.²¹ For conditions like CRS, evidence suggests that delaying vital surgery can lead to reduced postoperative quality of life (QoL),²² increased postoperative health care needs,²³ and reduced olfactory improvement.²⁴

Our nasal acoustic device (NAD) is based on a novel "stethoscope" concept whereby an acoustic sensor is placed over each nasal ala enabling the measurement of nasal airflow bilaterally and in real time. Importantly our novel "stethoscope" technique eliminates distortion of nasal airflow which occurs when airflow directly contacts the acoustic sensor, which has been trialed elsewhere albeit unsuccessfully.²⁵⁻²⁸ This noninvasive technique helps diagnose nasal obstruction as well as diagnosing the underlying cause for nasal obstruction based on nasal disease specific acoustic scores.

Our NAD could revolutionize the way patients with nasal complaints are managed in primary care through diagnosing the underlying condition, better streamlining treatment, and reducing costly secondary care referrals. In the COVID-19 recovery phase this device would complement telemedicine consultations by providing a noninvasive assessment, enabling safe triaging, and a treatment service without the need to come to hospital.

The aim of this pilot study is to evaluate the accuracy of the NAD in diagnosing nasal obstruction as well as the cause of nasal obstruction in accordance with standards for reporting diagnostic accuracy studies (STARD) guidelines.²⁹ This is based on the hypothesis that different nasal conditions display different responses to nasal

decongestant, and that these changes give useful diagnostic information which is specifically picked up by the NAD.

2 | MATERIALS AND METHODS

To maintain accuracy and transparency of our results, this pilot study was described and carried out in accordance with STARD guidelines following its list of essential items.²⁹ The study took place at the Royal National Throat, Nose and Ear Hospital, with ethical approval from London—City & East Research Ethics Committee.

2.1 | Subject recruitment

Written consent was obtained from all participants. Control subjects were recruited from University College London. Patients with nasal obstruction were recruited by inviting those referred to consultant ENT surgeon (coauthor P. A.) during hospital appointments.

Each subject was at least 18 years old, nonsmoker with no previous nasal surgery. Subjects with systemic diseases involving the nose such as sarcoid, vasculitis or nasal tumors were excluded. All patient and control subjects waited for at least 10 minutes in the waiting room before their assessment which allowed time for normalization of the nose and eliminated the effects of recent exercise. In addition, checking-in and filling out SNOT-22 questionnaires also facilitated this.

All control subjects were students from the university affiliated with the hospital (University College London) and underwent a full clinical evaluation which required a normal clinical history, normal nasal endoscopy (NE) evaluation, negative allergy tests and a SNOT 22 score of less than 10³⁰ to exclude AR, CRS, DNS, or any other sinonasal disease.

A patient's clinical diagnosis was based on the clinical history, nasendoscopic (NE) evaluation, computerized tomography (CT) findings, allergy tests along with SNOT-22 scores (a score of more than 10).^{30,31} Skin prick tests were used to diagnose allergic rhinitis as per the British Society of Allergy and Clinical Immunology guidelines.³²

CRS was diagnosed in accordance to the European Position Paper on Rhinosinusitis and Nasal Polyps (EPOS).⁶ Importantly all CRS without nasal polyps (CRSsNP) patients were recruited from our functional endoscopic sinus surgery waiting list having failed maximal medication in accordance with EPOS guidelines. All CRS patients had undergone a CT scan with Lund Mackay scores averaging more than 16. Importantly, patients with CRS with nasal polyps (CRSwnP) were excluded in this study to avoid the complexity of this additional variable of nasal polyps causing nasal blockage. In addition, unilateral sinonasal disease was excluded such as odontogenic disease.

A clinical diagnosis of a DNS was based on the clinical history, NE evaluation and CT scan findings. Patients with mucosal disease, were re-examined after decongestant to fully confirm the diagnosis of a DNS. Importantly we recruited only the DNS patients who required surgical intervention following failed maximum medical treatment.

The severity of the DNS was not quantified because a universal DNS grading system was not in common use at the time.

Patients were recruited if they had at least one of AR, CRS or DNS or any combination of these. Patients with internal valve or external valve deficiency were excluded.³³ A pragmatic approach was taken regarding patients taking oral and intranasal medications for their nasal obstruction, and these were not excluded.

2.2 | Method of study

NIPF and nasal breathing sounds were measured for each subject before and 10 minutes after applying nasal decongestant (three sprays into each nostril), consisting of phenylephrine hydrochloride 0.5% w/v, local anesthetic (lidocaine hydrochloride 5% w/v), preservative (benzalkonium chloride), and distilled water. The nasal decongestant eliminates the nasal cycle,³⁴ and is routinely used in assessment of the nose.³² Our hypothesis is that specific nasal diseases display unique responses to decongestant and expands further on the decongestable and non-decongestable nasal obstruction hypothesis outlined by Chin et al.¹⁵

2.3 | Nasal inspiratory peak flow meter

Each subject (in a sitting position) took a deep breath out before applying the NIPF face mask and made a single inspiration at maximum effort and speed, through the nose only. The highest of three measurements was used for analysis. uNIPF was measured in the same manner, with one nostril being covered with tape (3M Micropore Paper Tape, 3M Company, USA).

2.4 | Nasal acoustic device

Figure 1 shows a diagram of the NAD and Figure 2 shows an acoustic recording example and Figure 3 demonstrates the prototype being worn by a subject. A modified, contact-based piezo-electric microphone (Nordell Acoustic Guitar Pickup, Dangleberry Music, UK) was placed on each side of the nose, and secured using double-sided tape (Body Tape, Eylure, UK).

The microphones were connected to an amplifier (Stage Line MPA-202, Monacor International, Germany) with 65 dBa amplification and a high-pass filter at 60 Hz. The amplifier is connected to a stereo sound card (SW-29545, Sewell Direct, USA) which is connected to a laptop (Dell Inspiron 5567, Dell, USA). A MATLAB program (MATLAB R2018a, MathWorks, USA) acquires the signal at 44 100 Hz sampling frequency. The laptop and amplifier were connected to the mains power supply via a medical grade isolation transformer (REOMED 200-230 V, REO AG, Germany). The system was tested and certified for electrical safety by University College London Hospital. Nasal breathing sounds were recorded for 30 seconds at a light-to-moderate breathing effort.

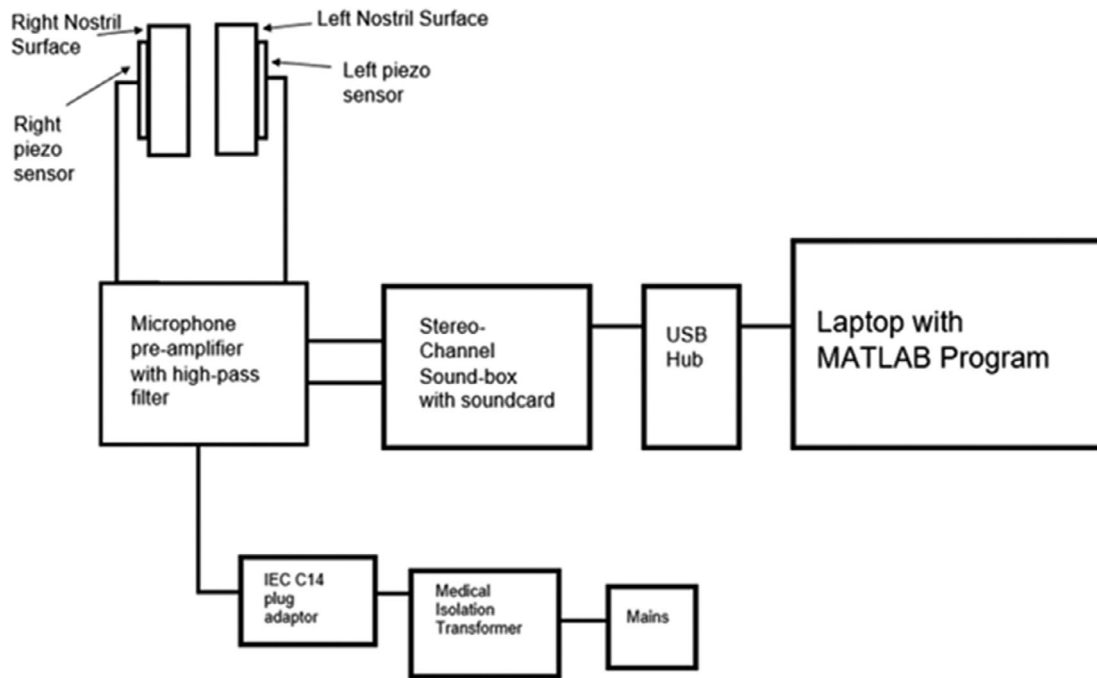

FIGURE 1 Block diagram of components for the nasal acoustic device

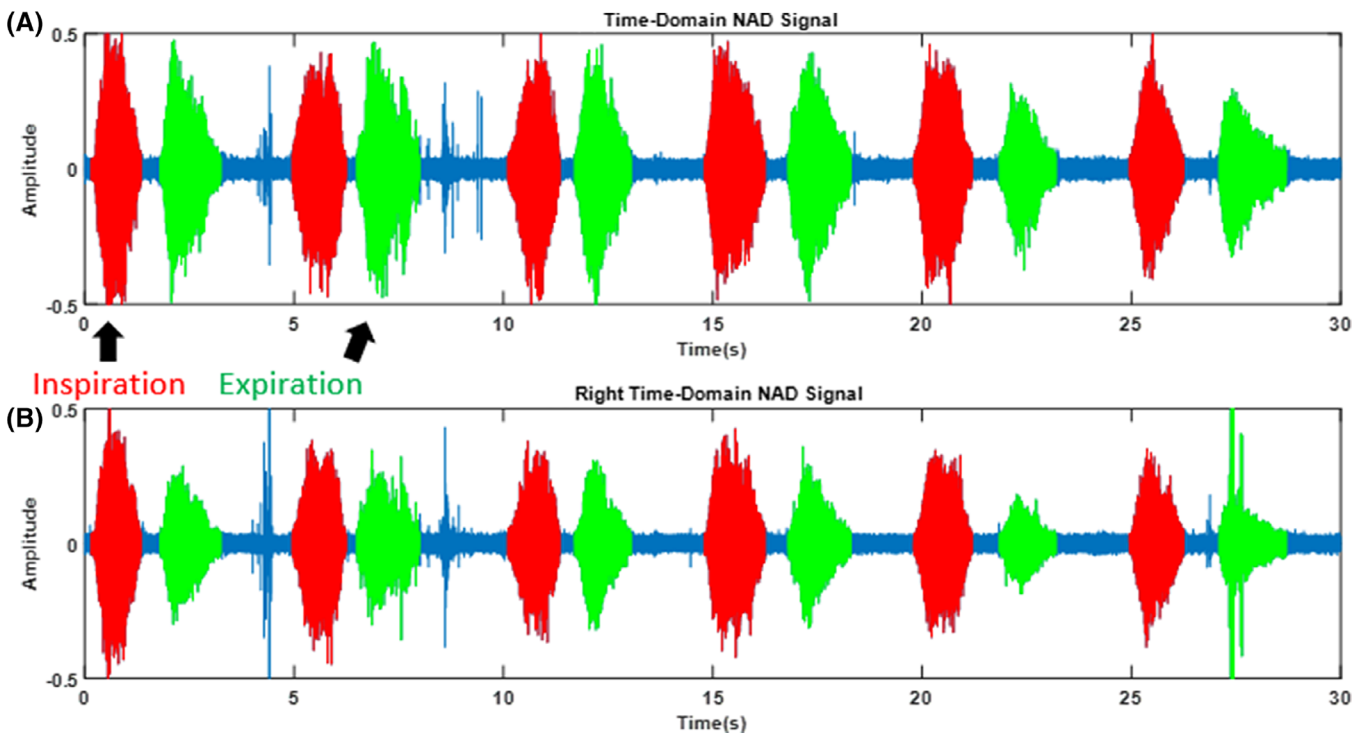

FIGURE 2 An example of time-domain acoustic signals. The left, A, and right, B, sides are recorded unilaterally and simultaneously. Red and green shows the inspiration and expiration respectively as detected by the nasal acoustic device. Blue parts were considered background noise

The quality of the sound recording was verified by observing the signal read out as shown by the MATLAB program (graph of acoustic power against time). The placement of the sensors was adjusted accordingly to give the optimal quality recording. In our initial testing of the NAD we found that if the wires attached to the NAD were not

fully supported, the weight could potentially open up the internal nasal valve area. In all subsequent recording we ensured that the wires were fully supported by placing them over the ear and using tape where necessary to avoid the apparatus causing distortion to the nasal airway.



FIGURE 3 Subject wearing NAD prototype

2.5 | Data analysis

A MATLAB program analyses the acoustic signals. It further bandpass-filtered the signals at 100 Hz-10 kHz; 100 Hz because the analogue filter was insufficient at attenuating the 50 Hz/60 Hz mains noise; and 10 kHz because spectrogram observations show almost the entirety of the acoustic signals falls below this.

The program uses a segmentation algorithm to detect nasal inspirations and expirations, verified by listening to the audio files. The program calculates various acoustic metrics from the inspirations and expirations which are analyzed for their potential diagnostic value.

Four sets of analyses were performed; each test involves distinguishing between two groups of subjects. These are:

1. All controls vs all patients.
2. All subjects without AR vs with AR.
3. All subjects without CRS vs with CRS.
4. All subjects without DNS vs with DNS.

For the latter three tests, the two groups are distinguished by the presence or absence of the condition in question, irrespective of other conditions being present. For example, in test 3, all CRS-subjects have CRS, but many also have AR and/or DNS; whereas non-CRS subjects are either controls or patients with AR and/or DNS. As over half the patients have more than one conditions, it would be impractical to analyze only single-condition patients. This method of comparison also better reflects the heterogeneity of the subjects recruited and indeed clinical practice.

Each test uses a specific acoustic metric to distinguish between the two groups. This study presents a novel nasal acoustic (NA) score

shown in Equation (1). The NA score is the average acoustic power during inspiration (INA) or expiration (ENA) at a specific frequency, expressed as a percentage of the acoustic power for the entire 10-10 kHz spectrum. It is affected by how power is distributed across the frequency spectrum. The theory is that different nasal conditions affect acoustic characteristics (and thus power distribution) of the breathing sounds differently. Another reason for normalization was to account for the fact that patients breathe at different efforts. A bilateral NA score is given as the average of the right and left measurements. Average is also found for all breathing phases in the recording. The NA score was used to compare between controls vs patients, non-AR vs AR, and non-CRS vs CRS.

$$\text{NA score} = \frac{\sum_{f=F1}^{f=F2} (\text{FT}_f[x_{\text{INSP}}])^2}{\sum_{f=100}^{f=10000} (\text{FT}_f[x_{\text{INSP}}])^2} * 100 \quad (1)$$

where FT is the Fourier transform; x_{INSP} represents the time-domain signals in the inspiratory or expiratory phase; f = frequency; $F1$ = lower boundary of the chosen frequency band; and $F2$ = upper boundary.

The NA score is specific to a frequency boundary, so there is an optimal frequency range to best distinguish between the two groups. This was found through an automated MATLAB process, and decided based on the Youden's J statistic (Equation 2³⁵). This single number indicates the overall sensitivity and specificity in distinguishing between two groups. It ranges from 0 to 1 (1 indicating perfect sensitivity and specificity). The process starts with 100 to 200 Hz, finding the J statistic. Then it moves along the frequency spectrum 100 Hz at a time (the next band being 200-300 Hz) until reaching 9900 Hz to 10 kHz. The bandwidth is then increased by 100 Hz and the process repeats (starting at 100-300 Hz) until 100-10 kHz is completed. The optimal frequency band is the one that gives the highest J value.

$$J = \text{Sensitivity} + \text{Specificity} - 1 \quad (2)$$

A second novel metric developed is the nasal obstruction balance index (NOBI) shown in Equation (3), used to compare non-DNS and DNS subjects. The magnitude of NOBI indicates the degree of asymmetry within the nose, and the sign indicates which side is dominant (positive indicates left side dominant). NOBI can also be frequency specific, using the aforementioned process to find the optimal range.

$$\text{NOBI} = \frac{P_L - P_R}{\text{MAX}(P_L, P_R)} * 100, \text{ where } P = \sum_{f=F1}^{f=F2} (\text{FT}_f[x_{\text{INSP}}])^2 \quad (3)$$

NOBI can also be applied to unilateral NIPF, where P_L and P_R are replaced with the left and right uNIPF measurements, respectively.

2.6 | Statistical analysis

Mann-Whitney U test was used to find out if two groups compared have statistically significant difference ($P < .05$ considered significant).

Results are presented in the form of optimal sensitivity, specificity, positive predictive value (PPV), and negative predictive value (NPV), found using the receiver operating characteristic curve utilizing the aforementioned Youden's J statistic. The threshold value used to distinguish between the two groups of subjects was also found. 95% confidence interval (CI) was given for sensitivity and specificity.

The threshold value and median values for the post-decongestant percentage change in the nasal acoustic score may be positive or negative but does not directly represent a direct increase or decrease in acoustic power following nasal decongestion. Instead it reflects the distribution of acoustic power within the specified range and a positive score would indicate more of the acoustic power is within the specified range after decongestant and a negative score shows that less acoustic power lies within the specified range after decongestant. For example, in Table 4, AR has a positive score of 9.2 which demonstrates that more of the sound lies within the 1700 to 3400 Hz specified range and for non-AR the score is -17.4 implying less of the acoustic power is in the 1700 to 3400 Hz frequency range post-decongestant.

3 | RESULTS

Table 1 displays the demographics of the subjects based on their conditions. Twenty-seven patients (mean age 33 ± 9 ; 15 males and 12 females) and 26 controls. Thirteen controls (mean age 23 ± 2 , with 10 males and 3 females) took part in the diagnostic accuracy study and a further 13 controls (mean age 24 with 6 males and 7 females) were later recruited to establish reproducibility in the control arm. Table 2 displays the breakdown of the number of subjects for each test group. Among the DNS subjects, 14 had unilateral DNS and eight had bilateral DNS (patients with anterior and posterior deviations on different sides).

3.1 | Control vs patient test

Pre-decongestant ENA score at 2100-4600 Hz was used to distinguish between controls ($n = 13$) and patients ($n = 27$), with a sensitivity of 0.81 (95% CI: 0.66-0.96) and a specificity of 0.77 (0.54-1.00).

TABLE 1 The number of subjects for each condition (or combination of conditions)

Subject groups	n
Controls	13
AR only	2
CRS only	2
DNS only	9
AR + CRS	1
AR + DNS	5
CRS + DNS	2
AR + CRS + DNS	6

Abbreviations: AR, allergic rhinitis; CRS, chronic rhinosinusitis; DNS, deviated nasal septum.

This was compared with pre-decongestant NIPF, with a sensitivity of 0.68 (0.51-0.85) and specificity of 0.92 (0.76-1.00). There was a statistically significant difference between patients and controls using both methods (Table 3).

3.2 | Allergic rhinitis vs non-AR test

Post-decongestant percentage change in INA score at 1700-3400 Hz was used to identify the presence of allergic rhinitis, with a sensitivity of 0.87 (0.69-1.00) and a specificity of 0.72 (0.55-0.89). Post-decongestant percentage change in NIPF had a lower sensitivity and specificity, 0.50 (0.27-0.73) and 0.57 (0.25-0.79) respectively. There was no statistically significant difference between the AR and non-AR groups using the NIPF metric ($P = 0.203$) (Table 4).

3.3 | Chronic rhinosinusitis vs non-CRS test

Post-decongestant percentage change in INA score at 1600 to 6400 Hz was used to identify the presence of CRS, with a sensitivity of 0.92 (0.74-1.00) and a specificity of 0.69 (0.52-0.86). When using post-decongestant percentage change in NIPF as the metric, the sensitivity was 0.89 (0.68-1.00) and specificity 0.34 (0.17-0.51). There was no statistically significant difference between the CRS and non-CRS groups using the NIPF metric (Table 5).

3.4 | Deviated nasal septum vs non-DNS test

Post-decongestant inspiratory NOBI at 100 to 5000 Hz was used to identify DNS, with a sensitivity of 0.77 (0.59-0.95) and a specificity of 0.94 (0.82-1.00). This was compared against post-decongestant NOBI for unilateral NIPF, which gave a sensitivity of 0.68 (0.48-0.88) and specificity of 0.83 (0.65-1.00). There was a significant difference between the DNS and non-DNS groups using both metrics (Table 6).

3.5 | Comparison of original vs new control groups: Reproducibility validation

To show that these results are reproducible we carried out NIPF and NAD recordings in a new group of 13 controls and compared the results with the original control group. The median pre-decongestant ENA score at 2100 to 4600 Hz frequency for both groups were very similar, as were the pre-decongestant NIPF scores. The two groups were not found to be statistically different ($P = .383$ for the ENA score and $P = .456$ for NIPF).

3.6 | Repeatability

The NAD and NIPF testing were repeated again on five of the patient study group within 4 weeks of the original testing and a significant

TABLE 2 The number of subjects for each test

Patients vs controls	n	Test for AR	n	Test for CRS	n	Test for DNS	n
Controls	13	Non-AR	25	Non-CRS	29	Non-DNS	18
Patients	27	AR	15	CRS	11	DNS	22

Abbreviations: AR, allergic rhinitis; CRS, chronic rhinosinusitis; DNS, deviated nasal septum.

TABLE 3 Results for controls vs patients test

Controls vs patients Metric (unit)	NIPF		NAD	
	Pre-decongestant flow (L/min)		Pre-decongestant ENA at 2100-4600 Hz (%)	
Median (range)	Controls	Patients	Controls	Patients
	175 (128-280)	102 (30-289)	29.1 (6.0-58.0)	20.4 (3.4-42.5)
Threshold	101		27.0	
Sensitivity (95% CI)	0.68 (0.51-0.85)		0.81 (0.66-0.96)	
Specificity (95% CI)	0.92 (0.76-1.00)		0.77 (0.54-1.00)	
Youden	0.60		0.58	
Statistically significant difference between the two groups?	Yes ($P = .003$)		Yes ($P = .004$)	
PPV	0.94		0.88	
NPV	0.60		0.67	

Abbreviations: CI, confidence interval; ENA, expiratory nasal acoustic score; NAD, nasal acoustic device; NIPF, nasal inspiratory peak flow; NPV, negative predictive value; PPV, positive predictive value.

TABLE 4 Results for allergic rhinitis vs nonallergic rhinitis test

Non-AR vs AR Metric (unit)	NIPF		NAD	
	Post-decongestant percentage change (%)		Post-decongestant percentage change in INA at 1700-3400 Hz (%)	
Median (range)	Non-AR	AR	Non-AR	AR
	30.3 (-35.3 to 105.1)	38.9 (-50.0 to 433.3)	-17.4 (-70.3 to 232.1)	9.2 (-53.1 to 686.1)
Threshold	28		-2	
Sensitivity (95% CI)	0.50 (0.27-0.73)		0.87 (0.69-1.00)	
Specificity (95% CI)	0.57 (0.25-0.79)		0.72 (0.55-0.89)	
Youden	0.29		0.59	
Statistically significant difference between the two groups?	No ($P = .203$)		Yes ($P = .010$)	
PPV	0.40		0.65	
NPV	0.67		0.90	

Abbreviations: AR, allergic rhinitis; CI, confidence interval; NAD, nasal acoustic device; NIPF, nasal inspiratory peak flow; NPV, negative predictive value; INA, inspiratory nasal acoustic score; PPV, positive predictive value.

difference between the original and repeated NIPF and NAD measurements was not demonstrated for either pre-decongestant NIPF or ENA ($P = .40$ for the pre-decongestant ENA score and $P = .46$ for NIPF).

4 | DISCUSSION

In this pilot study we have demonstrated that our novel NAD can help distinguish between normal and abnormal nasal breathing. The NAD pre-decongestant ENA scores can accurately and reproducibly detect the presence of nasal obstruction in our patient group compared to

normal nasal breathing in our control subjects. Importantly the NAD has the potential to improve the patient's understanding of their nasal obstruction through real time graphical readouts. The NAD would also help those patients who feel they have a problem but be reassured when they see objective evidence that their nasal airway is in fact within normal limits. In addition, the NAD can measure acoustic power from both nostrils simultaneously, using nonforced natural breathing methods which adds further value to the assessment of the nasal airway.

We have also demonstrated that the NAD can help diagnose the cause of nasal blockage, which is a novel finding and has not been invented before. The inspiratory nasal acoustic (INA) score, expiratory

TABLE 5 Results for chronic rhinosinusitis vs nonchronic rhinosinusitis test

Non-CRS vs CRS Metric (unit)	NIPF		NAD	
	Post-decongestant percentage change (%)		Post-decongestant percentage change in INA at 1600-6400 Hz (%)	
Median (range)	Non-CRS 33.3 (–50.0 to 433.3)	CRS 12.5 (–28.0 to 150.0)	Non-CRS 18.2 (–48.3 to 58.1)	CRS –3.8 (–29.4 to 99.1)
Threshold	51		–10	
Sensitivity (95% CI)	0.89 (0.68–1.00)		0.92 (0.74–1.00)	
Specificity (95% CI)	0.34 (0.17–0.51)		0.69 (0.52–0.86)	
Youden	0.23		0.60	
Statistically significant difference between the two groups?	No (P = .225)		Yes (P = .005)	
PPV	0.30		0.53	
NPV	0.91		0.95	

Abbreviations: CI, confidence interval; CRS, chronic rhinosinusitis; INA, inspiratory nasal acoustic score; NAD, nasal acoustic device; NIPF, nasal inspiratory peak flow; NPV, negative predictive value; PPV, positive predictive value.

TABLE 6 Results for deviated nasal septum vs nondeviated nasal septum test

Non-DNS vs DNS Metric (unit)	NIPF		NAD	
	uNIPF post-decongestant NOBI (%)		Post-decongestant inspiratory NOBI at 100-5000 Hz (%)	
Median (range)	Non-DNS 15.7 (0.0-55.7)	DNS 44.6 (0.0-100.0)	Non-DNS 36.9 (2.1-64.8)	DNS 62.5 (22.6-96.1)
Threshold	31		51	
Sensitivity (95% CI)	0.68 (0.48-0.88)		0.77 (0.59-0.95)	
Specificity (95% CI)	0.83 (0.65-1.00)		0.94 (0.82-1.00)	
Youden	0.52		0.71	
Statistically significant difference between the two groups?	Yes (P = .001)		Yes (P = .000)	
PPV	0.83		0.94	
NPV	0.67		0.77	

Abbreviations: CI, confidence interval; DNS, deviated nasal septum; NAD, nasal acoustic device; NPV, negative predictive value; NIPF, nasal inspiratory peak flow; NOBI, nasal obstruction balance index; uNIPF, unilateral nasal inspiratory peak flow; PPV, positive predictive value.

nasal acoustic (ENA) score, and NOBI score were significantly superior in the diagnosis of AR, CRS, and DNS when compared to NIPF. The NAD requires pre- and post-decongestant acoustic change measurements so as to eliminate the natural nasal cycle which originally posed significant challenges during the early stages of this study as well as facilitate the acoustic score evaluation.³⁶ The subsequent pre- and post-decongestant acoustic score measurements demonstrated acoustic shifts that were specific to either AR, CRS or DNS.

In parallel, we have identified the unique decongestable and non-decongestable characteristics of AR and CRS with regards to their NIPF percentage change following decongestant and how this facilitates diagnosis. AR produces a larger decongestant change when compared to CRS and this characteristic has not been described before in the literature and underlies the basis of our NAD diagnosis. NIPF change in decongestable and non-decongestable nasal disease has been described by Chin et al but not extrapolated for CRS and AR

diagnosis.¹⁵ We hypothesize that AR represents a more vascular and reversible disease process; whereas CRS represents a more chronic fibrosis disease process and less reversible.³⁷

According to our patient end user questionnaire, the NAD fulfills the desired requirements for the ideal nasal blockage diagnostic device. These include measuring normal nasal breathing and not relying on a nonphysiological measuring process such as forced inspiration currently used in NIPF. The NAD also enables visualization of real time nasal breathing on a computer screen and provides a digital outcome measurement, which complements future digital health care.

A significant, but unavoidable, hurdle faced in this pilot study was the absence of a commercially available reference standard which could diagnose the cause of nasal blockage owing to the fact that such a device has not been invented. The nearest alternative was to use a validated medical device which measures nasal airflow. The two options available included either NIPF or active anterior

rhinomanometry (AAR). We chose NIPF as it is widely used in our practice and is easy to use. NIPF is a validated tool used in the assessment of nasal airflow which in our practice has been used as a surgical outcome measurement tool for CRS and DNS treatment.^{36,38} Although AAR is considered the gold standard for the measurement of nasal resistance, Ottaviano et al³⁹ demonstrated NIPF to be as accurate as AAR in identifying nasal obstruction. Importantly, AAR will be utilized in future validation studies.

Nasal acoustic breathing sounds are caused by turbulent air flow interacting with the internal nasal architecture and nasal mucosa. This mechanism underpins the NAD and determines how it diagnoses the cause of nasal blockage.²⁵ Nasal pathology affects the internal nasal anatomy and mucosa differently. For example, AR causes inflammation predominantly of the mucosa overlying the inferior turbinate (IT) with subsequent swelling, with less effect on the middle turbinate. Whereas, CRS causes more middle turbinate inflammation and less IT swelling. Consequently, the internal characteristics of the nose according to its pathology produces a disease specific acoustic signature based on the acoustic power produced at specific frequencies. Alterations in the power distribution will affect the INA and ENA scores which are defined as the percentage of total power that exists within a specified frequency band. The results of this study support the hypothesis that different nasal conditions give rise to different acoustic patterns.

4.1 | Repeatability/reproducibility

The pre-decongestant ENA scores of the original 13 controls in our diagnostic accuracy study were compared to the pre-decongestant ENA scores of a newly recruited group of 13 controls and a significant difference was not demonstrated. Although reassuring with regards to our control group reproducibility performance, we did not perform a full reproducibility validation owing to the small sample size of our pilot study and we aim to explore this in future studies. Equally the repeatability in the patient group was reassuring, albeit performed only on 5 patients, and this will also need to be expanded upon in the future.

4.2 | Study limitations

The main limitation of this pilot study was the small sample size used for our control and patient groups which resulted in the large 95% confidence intervals (Tables 3-6). Interestingly similar diagnostic accuracy outcomes were found underpinning NIPF and this is now considered a well-established measurement tool.^{10,39} Although this pilot study was undertaken to demonstrate proof of concept, we have shown that there is a need to perform a larger study to further validate the diagnostic accuracy outcomes of the NAD.

A further limitation of this study was the heterogeneity of nasal pathologies found within each of the CRS, AR and DNS patient groups. This is not surprising given how common AR and CRS is

within the community. There is a need to have more homogenous nasal disease groups when performing a future diagnostic accuracy study with arms containing only pure CRS, AR or DNS. However, there is a need to have a mixed arm which would demonstrate a more realistic presentation. CRSwNP was excluded in this study to avoid the complexity of this additional variable of nasal polyps causing nasal blockage. However, this will be explored in future studies. We are also keen on grading the severity of DNS in future studies so as to validate the NAD accordingly.

In addition, there is a need to better age match the patient and control groups for future studies. The mean age of our control group was 10 years younger than that of the patient group which is a consequence of recruiting controls from a younger medical student population. This poses a limitation in terms of generalizability and drawing conclusions about differences between controls and patients in this study. As already highlighted, the NIPF was our reference standard in this pilot study but there is a need to include other measurement tools such as four-phase rhinomanometry. This will enable the NAD to be compared against medical devices which measures nasal airflow and resistance.

This pilot study primarily focused on diagnosing nasal obstruction (normal and abnormal nasal breathing) as well as the cause of nasal obstruction but not the severity of nasal obstruction. In our future studies we aim test the ability of the NAD to measure nasal obstruction severity, compared against both patient and clinician reported measures of NO severity. This will be important in improving patient education regarding NO presence, severity and response to treatment.

4.3 | Future applications

In these unprecedented COVID-19 times, the consequent health service recovery phase will require a major shift, particularly in ENT. This will involve improving and expanding ENT services within the community to help address the enormous backlog within secondary care and help reduce the need for face-to-face consultations in outpatients where capacity is reduced. The recovery phase will draw upon current adoption practices of COVID-19 such as teleconference consultations and triaging.

The NAD would also complement teleconference consultations particularly in primary care by providing a diagnosis which would complement the clinical history and help streamline referrals on to secondary care. Importantly, the teleconference consultations could be led by a nurse specialist or pharmacist in the community setting and thus promote more cost-efficient health care provision. We envisage the NAD to have Bluetooth and smartphone compatibility for ease of use. The current COVID-19 recovery phase has further catalyzed the current push to streamline diagnostics in primary care¹⁶ and reduce costly unnecessary secondary care referrals.

The NAD is unique in that it is a noninvasive method of assessing the nasal airway that uses equipment that can easily be sterilized which minimizes the risk of virus transmission. This is a significant advantage over current tools, including NIPF, acoustic rhinometry and

rhinomanometry that either involve forced breathing or instrumentation of the nose.

5 | CONCLUSION

We have demonstrated that the NAD can help diagnose normal and abnormal nasal breathing and diagnose AR, CRS, and DNS based on their specific acoustic scores. The NAD can uniquely measure breathing sounds from both sides of the nose simultaneously using non-forced natural breathing to produce a patient friendly computer read out. However, a larger diagnostic accuracy study is required to further validate this device. Its future application lies in the management of patients in the community setting thereby streamlining diagnostics in primary care and reducing the burden on secondary care. This will become more relevant in managing the backlog created by COVID-19.

ACKNOWLEDGMENTS

The authors would like to thank the subjects and the hospital nurses for their assistance in the study. This project has received funding from the Engineering and Physical Sciences Research Council.

CONFLICT OF INTEREST

None to declare.

ORCID

Anika Kaura  <https://orcid.org/0000-0003-3563-5164>

Katherine L. Whitcroft  <https://orcid.org/0000-0002-1417-0049>

Terence S. Leung  <https://orcid.org/0000-0001-5680-2625>

Peter Andrews  <https://orcid.org/0000-0001-5731-3276>

BIBLIOGRAPHY

- Jessen M, Malrn L. Definition, prevalence and development of nasal obstruction. *Allergy*. 1997;52:3-6. <https://doi.org/10.1111/j.1398-9995.1997.tb04876.x>.
- Nip L, Tan M, Whitcroft K, Gupta R, Leung T, Andrews P. Patient experience of nasal obstruction and its clinical assessment. *J Laryngol Otol*. 2018;132(4):318-322. <https://doi.org/10.1017/s0022215117002146>.
- Andrews P, Choudhury N, Takhar A, Poirrier A, Jacques T, Randhawa P. The need for an objective measure in septorhinoplasty surgery: are we any closer to finding an answer? *Clin Otolaryngol*. 2015;40(6):698-703. <https://doi.org/10.1111/coa.12455>.
- Price D, Scadding G, Ryan D, et al. The hidden burden of adult allergic rhinitis: UK healthcare resource utilisation survey. *Clin Transl Allergy*. 2015;5(1):39. <https://doi.org/10.1186/s13601-015-0083-6>.
- Hastan D, Fokkens W, Bachert C, et al. Chronic rhinosinusitis in Europe—an underestimated disease. A GA2LEN study. *Allergy*. 2011;66(9):1216-1223. <https://doi.org/10.1111/j.1398-9995.2011.02646.x>.
- Fokkens W, Lund V, Mullol J, et al. EPOS 2012: European position paper on rhinosinusitis and nasal polyyps 2012. A summary for otorhinolaryngologists. *Rhinol J*. 2012;50(1):1-12. <https://doi.org/10.4193/rhino50e2>.
- Ryan D, van Weel C, Bousquet J, et al. Primary care: the cornerstone of diagnosis of allergic rhinitis. *Allergy*. 2008;63(8):981-989. <https://doi.org/10.1111/j.1398-9995.2008.01653.x>.
- Local Government Association. Millions of 'unnecessary' GP visits are for coughs and colds; 2016. <https://www.local.gov.uk/about/news/millions-unnecessary-gp-visits-are-coughs-and-colds>. Accessed June 2017.
- Scadding G, Hellings P, Alobid I, et al. Diagnostic tools in rhinology EAACI position paper. *Clin Transl Allergy*. 2011;1(1):2. <https://doi.org/10.1186/2045-7022-1-2>.
- Ottaviano G, Scadding GK, Coles S, Lund VJ. Peak nasal inspiratory flow; normal range in adult population. *Rhinol J*. 2006;44(1):32-35.
- Tantilipikorn P. Peak nasal inspiratory flow: reference values for thais. *Siriraj Med J*. 2015;67(6):267.
- Bouzzargou M, Saad H, Chouchane A, et al. North African reference equation for peak nasal inspiratory flow. *J Laryngol Otol*. 2011;125(6):595-602. <https://doi.org/10.1017/s0022215111000181>.
- Ozkul H, Balikci H, Gurdal M, et al. Normal range of peak nasal inspiratory flow and its role in nasal septal surgery. *J Craniofac Surg*. 2013;24(3):900-902. <https://doi.org/10.1097/scs.0b013e318280263a>.
- Ottaviano G, Scadding G, Scarpa B, Accordi D, Staffieri A, Lund V. Unilateral peak nasal inspiratory flow, normal values in adult population. *Rhinol J*. 2012;50(4):386-392. <https://doi.org/10.4193/rhin12.071>.
- Chin D, Marcellis G, Malek J, et al. Nasal peak inspiratory flow (NPIF) as a diagnostic tool for differentiating decongestable from structural nasal obstruction. *Rhinol J*. 2014;52(2):116-121. <https://doi.org/10.4193/rhin13.126>.
- Transforming elective care services—ear, nose and throat (ENT). NHS, England. <https://www.england.nhs.uk/wp-content/uploads/2019/04/ear-nose-throat-elective-care-handbook.pdf>. Accessed December 1, 2019.
- ENT-UK guidance for ENT during the COVID-10 pandemic. <https://www.entuk.org/guidance-ent-during-covid-19-pandemic>. Accessed April 2020.
- Unadkat SN, Andrews PJ, Bertossi D, et al. Recovery of elective facial plastic surgery in the post-coronavirus disease 2019 era: recommendations from the European academy of facial plastic surgery task force. *Facial Plast Surg Aesth Med*. 2020;22:233-237. <https://doi.org/10.1089/fpsam.2020.0258>.
- Workman AD, Welling DB, Carter BS, et al. Endonasal instrumentation and aerosolization risk in the era of COVID-19: simulation, literature review, and proposed mitigation strategies. *Int Forum Allergy Rhinol*. 2020;10:798-805. <https://doi.org/10.1002/alr.22577>.
- Andrews P, Joseph J, Li C, Nip L, Jacques T, Leung T. A UK survey of current ENT practice in the assessment of nasal patency. *J Laryngol Otol*. 2017;131(8):702-706. <https://doi.org/10.1017/s0022215117001311>.
- Kaura A, Tan M, Whitcroft K, et al. A North London pilot survey to assess the need for a medical device in diagnosing chronic rhinosinusitis in primary care. *Open J Otolaryngol*. 2019;2(2):24-29.
- Hopkins C, Rimmer J, Lund V. Does time to endoscopic sinus surgery impact outcomes in chronic rhinosinusitis? Prospective findings from the National Comparative Audit of surgery for nasal pol. *Rhinol J*. 2015;53(1):10-17. <https://doi.org/10.4193/rhin13.217>.
- Hopkins C, Andrews P, Holy C. Does time to endoscopic sinus surgery impact outcomes in chronic rhinosinusitis? Retrospective analysis using the UK clinical practice research data. *Rhinol J*. 2015;53(1):18-24. <https://doi.org/10.4193/rhin14.077>.
- Whitcroft KL, Cuevas M, Andrews P, Hummel T. Monitoring olfactory function in chronic rhinosinusitis and the effect of disease duration on outcome. *Int Forum Allergy Rhinol*. 2018;8(7):769-776. <https://doi.org/10.1002/alr.22104>.
- Alshaer H, Fernie G, Bradley T. Monitoring of breathing phases using a bioacoustic method in healthy awake subjects. *J Clin Monit Comput*. 2011;25(5):285-294. <https://doi.org/10.1007/s10877-011-9307-z>.
- Seren E. Effect of the radiofrequency volumetric tissue reduction of inferior turbinate on expiratory nasal sound frequency. *Am J Rhinol*

- Allergy. 2009;23(3):316-320. <https://doi.org/10.2500/ajra.2009.23.3323>.
27. Choi H, Park I, Yoon H, Lee H. Comparison of nasal sound spectral analysis and peak nasal inspiratory flow before and after decongestion in patients with nasal obstruction. *Ann Otol Rhinol Laryngol*. 2011;120(6):391-396. <https://doi.org/10.1177/000348941112000608>.
 28. Primov-Fever A, Zaretsky U, Elad D, Wolf M. Evaluation of nasal airway patency by analysis of breathing sounds. *Acta Otolaryngol*. 2016;136(2):219-224.
 29. Bossuyt P, Reitsma J, Bruns D, et al. STARD 2015: an updated list of essential items for reporting diagnostic accuracy studies. *BMJ*. 2015;61(12):h5527. <https://doi.org/10.1136/bmj.h5527>.
 30. Erskine S, Hopkins C, Clark A, et al. SNOT-22 in a control population. *Clin Otolaryngol*. 2016;42(1):81-85. <https://doi.org/10.1111/coa.12667>.
 31. Takhar A, Stephens J, Randhawa P, Poirrier A, Andrews P. Validation of the sino-nasal outcome test-23 in septorhinoplasty surgery. *Rhinol J*. 2014;52(4):301-304. <https://doi.org/10.4193/rhin14.009>.
 32. Scadding G, Kariyawasam H, Scadding G, et al. BSACI guideline for the diagnosis and management of allergic and non-allergic rhinitis (revised edition 2017; first edition 2007). *Clin Exp Allergy*. 2017;47(7):856-889. <https://doi.org/10.1111/cea.12953>.
 33. Patel B, Virk J, Randhawa P, Andrews P. The internal nasal valve: a validated grading system and operative guide. *Eur Arch Otorhinolaryngol*. 2018;275(11):2739-2744. <https://doi.org/10.1007/s00405-018-5142-x>.
 34. Awad SS, Eccles R. Effect of pseudoephedrine on nasal airflow in patients with nasal congestion associated with common cold. *Rhinol J*. 1998;36:73-76.
 35. Youden W. Index for rating diagnostic tests. *Cancer*. 1950;3(1):32-35. [https://doi.org/10.1002/1097-0142\(1950\)3:1<32::aid-cnrcr2820030106>3.0.co;2-3](https://doi.org/10.1002/1097-0142(1950)3:1<32::aid-cnrcr2820030106>3.0.co;2-3).
 36. Tan M, Whitcroft K, Mehta N, Schilder A, Leung T, Andrews P. Investigating the nasal cycle using unilateral peak nasal inspiratory flow and acoustic rhinometry minimal cross-sectional area measurements. *Clin Otolaryngol*. 2019;44(4):518-524. <https://doi.org/10.1111/coa.13313>.
 37. Farmer SE, Eccles R. Chronic inferior turbinate enlargement and the implications for surgical intervention. *Rhinol J*. 2006;44(4):234-238.
 38. Kaura A, Virk J, Joseph J, Rennie C, Singh Randhawa P, Andrews P. The role of unilateral nasal inspiratory peak flow in nasal obstruction—a study of 70 patients undergoing septorhinoplasty surgery. *Clin Otolaryngol*. 2019;44(3):427-430. <https://doi.org/10.1111/coa.13295>.
 39. Ottaviano G, Lund V, Nardello E, et al. Comparison between unilateral PNIF and rhinomanometry in healthy and obstructed noses. *Rhinol J*. 2014;52(1):2-30. <https://doi.org/10.4193/rhin13.037>.

How to cite this article: Li C-H, Kaura A, Tan C, Whitcroft KL, Leung TS, Andrews P. Diagnosing nasal obstruction and its common causes using the nasal acoustic device: A pilot study. *Laryngoscope Investigative Otolaryngology*. 2020;1-11. <https://doi.org/10.1002/lio2.445>