



2807712579

ROYAL FREE THESES 1992

---

The Involvement of Calcium and Chloride Ions in the  
Regulation of Rat Leydig cell Steroidogenesis

---

ProQuest Number: 10797769

All rights reserved

INFORMATION TO ALL USERS

The quality of this reproduction is dependent upon the quality of the copy submitted.

In the unlikely event that the author did not send a complete manuscript and there are missing pages, these will be noted. Also, if material had to be removed, a note will indicate the deletion.



ProQuest 10797769

Published by ProQuest LLC (2018). Copyright of the Dissertation is held by the Author.

All rights reserved.

This work is protected against unauthorized copying under Title 17, United States Code  
Microform Edition © ProQuest LLC.

ProQuest LLC.  
789 East Eisenhower Parkway  
P.O. Box 1346  
Ann Arbor, MI 48106 – 1346

A Thesis submitted in accordance with the regulations  
governing candidates for the University of London

Degree of  
Doctor of Philosophy

presented by

Michael Shui Kuen Choi

MEDICAL LIBRARY  
ROYAL FREE HOSPITAL  
HAMPSTEAD.

Department of Biochemistry and Chemistry  
Royal Free Hospital School of Medicine

1992

**To Alice**  
**and my parents**

## ABSTRACT

Cyclic AMP (cAMP) has been established as a second messenger in the stimulation of testosterone production by luteinizing hormone (LH). The aim of this thesis was to investigate the possible involvement other regulators mediating the acute stimulation of steroidogenesis in purified testis Leydig cells. The possible involvement of calcium ions, chloride ions, pH, protein kinase C (PKC) and de novo synthesis of cholesterol were investigated.

Extracellular calcium was found to be essential for both maximum steroidogenesis and cAMP production. However, LH-stimulated increase in intracellular calcium could not be reproducibly demonstrated in cells loaded with fluorescent calcium indicator Fura 2. The involvement of calmodulin in testosterone production was investigated using the calmodulin inhibitor, calmidazolium. This compound inhibited cAMP production stimulated by LH, forskolin and cholera toxin, with  $ID_{50}$  of  $2\mu M$ . It had both a stimulatory and inhibitory effect on steroidogenesis. The stimulatory effect was an unexpected finding; it was independent of cAMP, calcium and protein synthesis, and was similar in magnitude to stimulation obtained with maximum levels of LH or dibutyryl cyclic AMP (dbcAMP). It also stimulated steroidogenesis in rat adrenocortical cells and mouse Leydig cells.

Using cells loaded with the fluorescent pH indicator BCECF, the intracellular pH was found to be pH 7.2, and the presence of the  $Na^+/H^+$  exchanger was demonstrated. Testosterone production was found to be relatively insensitive to fluctuations in intracellular pH.

It has been established that rat Leydig cells possess outward rectifying chloride channels on their plasma membrane. The replacement of extracellular chloride with gluconate salts caused a potentiation of the sub-maximal testosterone production in response to low concentrations of LH and dbcAMP. This potentiating effect of chloride replacement was also found in dbcAMP-stimulated pregnenolone production in rat adrenocortical cells. These results suggest that the efflux of chloride ions may play an important role in steroidogenesis. The chloride channel inhibitors, SITS and DIDS, inhibited both LH-stimulated cAMP and testosterone production, but had no effect on dbcAMP stimulated steroidogenesis. The precise role of SITS- and DIDS- sensitive

chloride channels remains unclear.

Both basal and stimulated testosterone production were stimulated two-fold when PKC activity was downregulated through preincubation with phorbol ester, phorbol 12-myristate,13-acetate (PMA). Preincubation with an inactive phorbol ester, phorbol 12,13-dideconoate (PDD), had no effect on testosterone production. The site of this potentiation was prior to cholesterol-side-chain-cleavage. Testosterone production in Leydig cells appears to be tonically inhibited by the action PKC.

Pertussis toxin-sensitive G-protein(s) has previously been found in Leydig cells. In the present studies, pertussis toxin was found to inhibit both LH- and dbcAMP-stimulated testosterone production. This suggests the involvement of pertussis toxin-sensitive G-proteins in the regulation of testosterone production.

The supply of cholesterol for testosterone production in rat Leydig cells is derived from de novo synthesis. It was found that de novo synthesis of cholesterol was not required for acute testosterone production. This indicates the existence of a large pool of steroidogenic cholesterol in rat Leydig cells.

## Acknowledgements

I wish to thank Professor Brian A. Cooke for his supervision, friendship and encouragement throughout my time in his laboratory and during the preparation of this manuscript. I am grateful to the Royal Free Peter Samuel Fund through the financial support of a Junior Research Fellowship. I would like to thank Dr. Mark Sullivan for his friendship and supervision during my first few months in a new laboratory.

My time at the Royal Free has been made memorable through the company and help of many colleagues in the Biochemistry department especially Ghenima Dirami, Dr. Robert Abayasakera, Dr. Matthew Rose, Arja Band, Dr. Pilar Lopez-Ruiz, Jane Atkin, Richard Preston, Vernon Skinner, Tony West, Joe Antoniew, Laiq Chaudry and John Morrison.

I would like to thank Dr. C. Richards and Kenneth Nigel in the department of physiology for their helpful advise and discussion on the measurement of intracellular calcium and pH. My thanks also go to Dave Hanks for his efficient ordering of research materials. My gratitude is extended to the many unnamed rodents that made my research possible.

Finally, I thank my parents for their support and encouragement throughout the many years of my education. My warmest thanks and love go to my wife Alice, who gave much patient encouragement and many evenings during the course of my research and in the writing of this manuscript.

# CONTENTS

	<u>Page</u>
<b>List of Figures</b>	8
<b>List of Tables</b>	16
<b>Abbreviations</b>	17
<b>Chapter 1 General Introduction</b>	18
<b>1.1 Structure and function of the testis</b>	19
<b>1.2 Endocrine control of testicular function</b>	26
<b>1.2.1 The pituitary gland</b>	26
<b>1.2.2 Regulation of LH/FSH secretion</b>	29
<b>1.2.3 Structure of LH and FSH</b>	31
<b>1.2.4 Structure of glycoprotein hormone receptors     - exemplified by the LH receptor</b>	33
<b>1.3 Regulation of testosterone production in Leydig cells   by luteinizing hormone</b>	38
<b>1.3.1 Conversion of cholesterol to testosterone</b>	38
<b>1.3.2 The supply of cholesterol for testosterone production</b>	44
<b>1.4 Intracellular mechanisms mediating the action of LH   in testis Leydig cells</b>	48
<b>1.4.1 The adenylate cyclase system</b>	48



1.4.2	The increase of intracellular calcium	52
1.4.3	The liberation and metabolism of arachidonic acid	53
1.4.4	The activation of protein kinase C	56
1.5	Intratesticular factors that regulate the function of Leydig cells	57
1.6	Aims of this project	58
<b>Chapter 2 Materials and Methods</b>		<b>59</b>
2.1	Materials	60
2.2	Methods	61
2.2.1	Cell isolation	61
2.2.2	Incubation medium	63
2.2.3	Incubation conditions	64
2.2.4	Measurement of testosterone, pregnenolone and cyclic AMP by radioimmunoassay.	65
2.2.5	Measurement of intracellular calcium using quin-2 and fura-2.	66
2.2.6	Measurement of intracellular pH changes using BCECF	72
<b>Chapter 3 Role of intracellular calcium in testosterone production.</b>		<b>73</b>
3.1	Introduction	74
3.2	Results	75

3.2.1	Calcium and testosterone production	75
3.2.2	Modulation of intracellular calcium ion concentrations	93
3.3	Discussion	108
<b>Chapter 4</b>	<b>The effect of calmidazolium, a calmodulin inhibitor, on testosterone production</b>	<b>114</b>
4.1	Introduction	115
4.2	Results	116
4.2.1	Effect of calmidazolium on cyclic AMP production	116
4.2.2	Effect of calmidazolium on testosterone production	122
4.3	Discussion	137
<b>Chapter 5</b>	<b>Role of intracellular pH in testosterone production</b>	<b>142</b>
5.1	Introduction	143
5.2	Results	145
5.3	Discussion	157
<b>Chapter 6</b>	<b>Chloride ions and testosterone production</b>	<b>159</b>
6.1	Introduction	160
6.2	Results	161
6.3	Discussion	178

<b>Chapter 7</b>	<b>The role of de novo cholesterol synthesis and acute testosterone production</b>	181
<b>7.1</b>	<b>Introduction</b>	182
<b>7.2</b>	<b>Results</b>	183
<b>7.3</b>	<b>Discussion</b>	190
<b>Chapter 8</b>	<b>The effect of phorbol esters and Pertussis toxin on testosterone production</b>	193
<b>8.1</b>	<b>Role of protein kinase C in cyclic AMP-stimulated testosterone production</b>	194
<b>8.2</b>	<b>The effect of pertussis toxin on LH- and dibutyryl cyclic AMP- stimulated testosterone production</b>	197
<b>Chapter 9</b>	<b>Summary and General Discussion</b>	200
<b>9.1</b>	<b>Summary and general discussion</b>	201
<b>9.2</b>	<b>Future work</b>	210
	<b>Bibliography</b>	212

## List of Figures

		<u>Page</u>
<b>Fig. 1.1</b>	Morphological relationship of the epididymis to the testis	20
<b>Fig. 1.2</b>	The structure and cellular associations of the seminiferous tubule	22
<b>Fig. 1.3</b>	Schematic representation of the spermatogenic cycle in the adult rat	24
<b>Fig. 1.4</b>	Cross-section through a small area of an adult rat testis	25
<b>Fig. 1.5</b>	Diagram to show the basic features of the development of the adeno- and neurohypophysis	27
<b>Fig. 1.6</b>	Summary of the functional inter-relationships between the hypothalamus and hypophysis	28
<b>Fig. 1.7</b>	Postulated topology of the LH.CG receptor in the plasma membrane	34
<b>Fig. 1.8</b>	Comparison of the LH.CG receptor with other "seven transmembrane" receptors	36
<b>Fig. 1.9</b>	Biosynthesis of pregnenolone from cholesterol	39
<b>Fig. 1.10</b>	Biosynthesis of the male and female steroid hormones	41
<b>Fig. 1.11</b>	Scheme showing proposed sites of action of phorbol esters-activated protein kinase C on the LH receptor-G protein-adenylate cyclase signal transducing system	51

<b>Fig. 2.1</b>	Structure and fluorescence characteristics of quin-2 and fura-2	67
<b>Fig. 2.2</b>	The effect of collagen on LH-stimulated testosterone production	68
<b>Fig. 2.3</b>	A system for measuring intracellular fluorescence using a cuvette and cells attached to a glass coverslip	71
<b>Fig. 3.1</b>	Dissociation between testosterone and cyclic AMP production in responds to stimulation with LH	76
<b>Fig. 3.2</b>	Effect of removing extracellular $\text{Ca}^{2+}$ on testosterone production stimulated with LH	77
<b>Fig. 3.3</b>	Effect of removing extracellular $\text{Ca}^{2+}$ on LH-8-bromo-cyclic AMP- stimulated testosterone production	78
<b>Fig. 3.4</b>	Effect of removing extracellular $\text{Ca}^{2+}$ on the conversion of 22(R)OH-cholesterol to testosterone	79
<b>Fig. 3.5</b>	Effect of Lanthanum ions on LH-stimulated testosterone production	80
<b>Fig. 3.6</b>	Effect of Lanthanum ion on LH-stimulated cyclic AMP and testosterone production	82
<b>Fig. 3.7</b>	Effect of Lanthanum ions on dibutyryl cyclic AMP stimulated testosterone production	83
<b>Fig. 3.8</b>	Effect of Lanthanum ions on the conversion of 22(R)OH-cholesterol to testosterone	85

<b>Fig. 3.9</b>	Effect of Nifedipine, an inhibitor of voltage-dependent calcium channels, on LH-stimulated testosterone production	86
<b>Fig. 3.10</b>	Effect of Nifedipine on LH-stimulated testosterone production in the presence and absence of extracellular calcium	87
<b>Fig. 3.11</b>	Effect of TMB-8, a putative inhibitor of calcium release from intracellular stores, on LH-stimulated testosterone production	88
<b>Fig. 3.12</b>	Effect of TMB-8, a putative inhibitor of calcium release from intracellular stores, on dibutyryl cyclic AMP-stimulated testosterone production	90
<b>Fig. 3.13</b>	Effect of A23187, a calcium ionophore, on LH- and dibutyryl cyclic AMP-stimulated testosterone production	91
<b>Fig. 3.14</b>	Effect of Thapsigargin, a specific inhibitor of the Ca <sup>2+</sup> /ATPase on the endoplasmic reticulum, on LH- and dibutyryl cyclic AMP- stimulated testosterone production	92
<b>Fig. 3.15</b>	The effect of chelating calcium with EGTA on the excitation spectrum of fura-2	95
<b>Fig. 3.16</b>	The effect of poly-L-lysine and fura-2 on LH-stimulated testosterone production	96
<b>Fig. 3.17</b>	The effect of angiotensin II and potassium on intracellular Ca <sup>2+</sup> levels in rat adrenal glomerulosa cells	98
<b>Fig. 3.18</b>	The effect of angiotensin II and potassium on intracellular Ca <sup>2+</sup> levels in bovine adrenal glomerulosa cells	99

<b>Fig. 3.19</b>	Effect of LH-stimulation on the fluorescence of fura-2 in rat Leydig cells on poly-L-lysine-coated glass coverslips	100
<b>Fig. 3.20</b>	The quenching of fura-2 fluorescence by manganese ions in rat Leydig cells on poly-L-lysine-coated coverslips	101
<b>Fig. 3.21</b>	The effect of manganese ions on intracellular fura-2 fluorescence in Leydig cells stimulated with LH and angiotensin II	103
<b>Fig. 3.22</b>	The effect of probenecid, an inhibitor of anion transport, on fura-2 fluorescence in LH-stimulated Leydig cells	104
<b>Fig. 3.23</b>	The measurement of fura-2 fluorescence in a superfused cuvette	106
<b>Fig. 3.24</b>	The measurement of fura-2 fluorescence in a superfused cuvette, another example of LH-stimulated fluorescence increase	107
<b>Fig. 4.1</b>	Effect of calmidazolium on basal cyclic AMP production in the presence and absence of extracellular calcium	117
<b>Fig. 4.2</b>	Effect of calmidazolium on LH-stimulated cyclic AMP production in the presence and absence of extracellular calcium	119
<b>Fig. 4.3</b>	Effect of calmidazolium on cholera toxin-stimulated cyclic AMP production in the absence and presence of extracellular calcium	120
<b>Fig. 4.4</b>	Effect of calmidazolium on forskolin-stimulated cyclic AMP production in the presence and absence of extracellular calcium	121

<b>Fig. 4.5</b>	Effect of calmidazolium on basal and LH-stimulated testosterone production	123
<b>Fig. 4.6</b>	Comparison between calmidazolium and LH-stimulated pregnenolone and testosterone production	124
<b>Fig. 4.7</b>	Time course of pregnenolone and testosterone production	127
<b>Fig. 4.8</b>	Effect of removing extracellular calcium on calmidazolium-stimulated testosterone production	128
<b>Fig. 4.9</b>	Comparison between the effect of Lanthanum ions on calmidazolium and LH-stimulated testosterone production	129
<b>Fig. 4.10</b>	Comparison between the effect of TMB-8, an inhibitor of intracellular calcium release, on basal, calmidazolium-, forskolin-, and LH-stimulated testosterone production	131
<b>Fig. 4.11</b>	The effect of cycloheximide, an inhibitor of protein synthesis, on calmidazolium-stimulated testosterone production	132
<b>Fig. 4.12</b>	The effect of calmidazolium on the conversion of 22(R)OH-cholesterol to testosterone	133
<b>Fig. 4.13</b>	The effect of aminoglutethimide, an inhibitor of cholesterol side-chain cleavage, on calmidazolium- and dibutyryl cAMP-stimulated testosterone production	135
<b>Fig. 4.14</b>	The effect of trifluoperazine, an inhibitor of calmodulin, on LH-stimulated testosterone production	136



<b>Fig. 5.1</b>	The ammonium prepulse technique for the study of intracellular pH	144
<b>Fig. 5.2</b>	Demonstration of pH regulation by the ammonium prepulse technique	146
<b>Fig. 5.3</b>	The influence of bicarbonate ions on pH recovery after a prepulse of ammonium	147
<b>Fig. 5.4</b>	Sodium ions are required for the recovery of intracellular pH in Leydig cells after cytoplasmic acidification	149
<b>Fig. 5.5</b>	Effect of amiloride, an inhibitor of the Na <sup>+</sup> /H <sup>+</sup> exchanger, on pH recovery after cytoplasmic acidification	150
<b>Fig. 5.6</b>	Bicarbonate ions are insufficient for the recovery of intracellular pH after cytoplasmic acidification	151
<b>Fig. 5.7</b>	Calibration of intracellular pH using nigericin, a K <sup>+</sup> -ionophore, in K <sup>+</sup> -HBSS	152
<b>Fig. 5.8</b>	Effect of NH <sub>4</sub> Cl on LH-stimulated testosterone production	154
<b>Fig. 5.9</b>	Effect of amiloride on LH-stimulated testosterone production	155
<b>Fig. 5.10</b>	LH-stimulated testosterone production in the presence and absence on NaHCO <sub>3</sub>	156
<b>Fig. 6.1</b>	Effect of removing extracellular chloride on LH-stimulated testosterone production	162

<b>Fig. 6.2</b>	Effect of removing extracellular chloride on dibutyryl cyclic AMP-stimulated testosterone production	163
<b>Fig. 6.3</b>	Effect of removing extracellular chloride on dibutyryl cyclic AMP- stimulated testosterone production in the presence of the phospho-esterase inhibitor, IBMX	164
<b>Fig. 6.4</b>	Time-course of LH-stimulated cyclic AMP production in the presence and absence of extracellular chloride with IBMX	165
<b>Fig. 6.5</b>	Effect of SITS, an inhibitor of chloride channels, on LH and dibutyryl cyclic AMP-stimulated testosterone production	167
<b>Fig. 6.6</b>	Effect of SITS, an inhibitor of chloride channels, on dibutyryl cyclic AMP-stimulated testosterone production	168
<b>Fig. 6.7</b>	Effect of SITS, an inhibitor of chloride channels, on LH-stimulated testosterone production in the presence and absence of IBMX	169
<b>Fig. 6.8</b>	Effect of DIDS, an inhibitor of chloride channels, on LH- and dibutyryl cyclic AMP-stimulated testosterone production	170
<b>Fig. 6.9</b>	Effect of DIDS, an inhibitor of chloride channels, on dibutyryl cyclic AMP- stimulated testosterone production	171
<b>Fig. 6.10</b>	Effect of DIDS, an inhibitor of chloride channels, on dibutyryl cyclic AMP- stimulated testosterone production in the presence and absence of LH	172

<b>Fig. 6.11</b>	Effect of DIDS, an inhibitor of chloride channels, on dibutyryl cyclic AMP- stimulated testosterone production in the absence of extracellular chloride ions	171
<b>Fig. 6.12</b>	Effect of DIDS, an inhibitor of chloride channels. on LH- and forskolin- stimulated cyclic AMP production	175
<b>Fig. 6.13</b>	Effect of DIDS, an inhibitor of chloride channels, on cholera toxin- stimulated cyclic AMP production	176
<b>Fig. 6.14</b>	Effect of replacing extracellular chloride on steroidogenesis in rat adrenocortical cells	177
<b>Fig. 7.1</b>	The effect of compactin, an inhibitor of HMGCoA reductase, on LH-stimulated testosterone production	184
<b>Fig. 7.2</b>	Effect of compactin on dibutyryl cAMP-stimulated testosterone production	185
<b>Fig. 7.3</b>	Effect of compactin on calmidazolium-stimulated, and the conversion of 22(R)OH-cholesterol to testosterone	186
<b>Fig. 7.4</b>	Effect of higher concentrations of compactin on dibutyryl cAMP- and LH- stimulated testosterone production	187
<b>Fig. 7.5</b>	Effect of higher concentrations of compactin on calmidazolium-stimulated, and the conversion of 22(R)OH-cholesterol to testosterone production	188
<b>Fig. 7.6</b>	Effect of progressive replacement of glucose with mevalonate on LH-stimulated testosterone production	189

<b>Fig. 8.1</b>	The effect of phorbol esters, PMA and PDD, on dibutyryl cAMP-stimulated testosterone production	196
<b>Fig. 8.2</b>	The effect pertussis toxin on LH- and dibutyryl cAMP- stimulated testosterone production	198
<b>Fig. 9.1</b>	A schematic diagram summarizing the possible mechanisms involved in the acute regulation of testosterone production in Leydig cells	209

#### List of Tables

<b>Table 4.1</b>	The stimulation of testosterone in mouse Leydig cells by calmidazolium	126
<b>Table 4.2</b>	The stimulation of pregnenolone production in rat adrenocortical cells by calmidazolium	126

## ABBREVIATIONS

A23187	Calcium ionophore
BCECF/AM	2',7'-bis-(carboxyethyl)-5(6')-carboxyfluorescein, pentaacetoxymethyl ester
Calmidazolium	1-[bis-(4-Chlorophenyl)methyl]-3-[2-(2,4--dichlorophenyl)-2-[(2,4-dichlorophenyl)methoxyl]-ethyl]-1H-imidazolium chloride
Cyclic AMP	Adenosine-3':5'-Cyclic Monophosphate
DIDS	4,4'-Diisothiocyanatostilbene-2,2'-disulphonic acid
DMEM	Dulbecco's modified Eagle's medium
DMSO	Dimethylsulphoxide
DTPA	Diethylenetriaminepentaacetic acid
EGTA	Ethyleneglycol-bis-( $\beta$ -aminoethyl)-N,N,N',N'-tetraacetic acid
Fura-2/AM	1: 1-[2-(5-carboxyoxazol-2-yl)-6-aminobenzofuran-5-oxy]-2-(2'-amino-5'-methylphenoxy)-ethane-N,N,N',N'-pentaacetoxymethyl ester
HBSS	Hanks' balanced salt solution
hCG	Human chorionic gonadotropin
IBMX	3-Isobutyl-1-methyl xanthine
LH	Luteinizing hormone
PDD	Phorbol 12,13-dideconoate
PMA	Phorbol 12-myristate,13-acetate
Quin-2/AM	2-{-bis-(carboxymethyl)-amino-5-methylphenoxy]-methyl}-6-methoxy-8-bis-(carboxymethyl)-aminoquinoline tetrakis-acetoxymethyl ester
SITS	4-Acetamido-4'-isothiocyanatostilbene-2,2'-disulphonic acid
SU-10603	7-Chloro-3,4-dihydro-2(3-pyridyl)-1(2H) naphthanlenone
TMB-8	3,4,5-Trimethoxybenzoic acid 8-(diethylamino)octyl ester

# **CHAPTER ONE**

## **General Introduction**

## **1.1 The Structure and Function of the Testis**

The functional role of the testes in reproduction and in the maintenance of the male secondary sex characteristics, has been appreciated since ancient times. Evidence for this comes from the long history and widespread use of eunuchs in the service of far-eastern and middle-eastern rulers. The commercial value of castration has also been utilized in chicken farming, where cockerels are castrated to produce the fattened capon. Indeed it was in capons that the first successful experiment in endocrinology was performed. In 1849, Berthold demonstrated that capons regained normal sexual behaviour and comb size after testes from normal cockerels were transplanted into their body cavity. He concluded that the 'testes affect the blood and thereby produce effects elsewhere in the body'. Since this pioneering experiment, the physiology and endocrinology of the testes has made considerable progress as a subject of study (for review see Setchell, 1983).

Like other specialized organs, the design of the testis is an expression of its function. From anatomical and physiological studies of the testis, it has been established that it is responsible for both sperm and androgen production. Hence, the testes are central to the reproductive ability of the male animal, and its general features have been conserved in all animals that possess them. Much of the research that has been carried out on the testis, has been in animals that are readily available, such as the rat and the mouse. The structure of the testis that will be described in this section, will be based on the rat testis.

The testis is an ovoid organ consisting of seminiferous tubules, interstitial cells, connective tissue, blood vessels and nerve endings. This is surrounded by a thick connective tissue capsule, known as the tunica albuginea (Fig. 1.1). The seminiferous

**Fig. 1.1. Morphological relationship of the epididymis to the testis.** Spermatozoa produced by the seminiferous tubules are transported via the rete testis to the caput epididymis. The spermatozoa undergo maturation as they pass through the caput epididymis to the cauda epididymis. The mature sperm are then stored in the cauda epididymis until they are ejaculated. (Cooke et al., 1973)



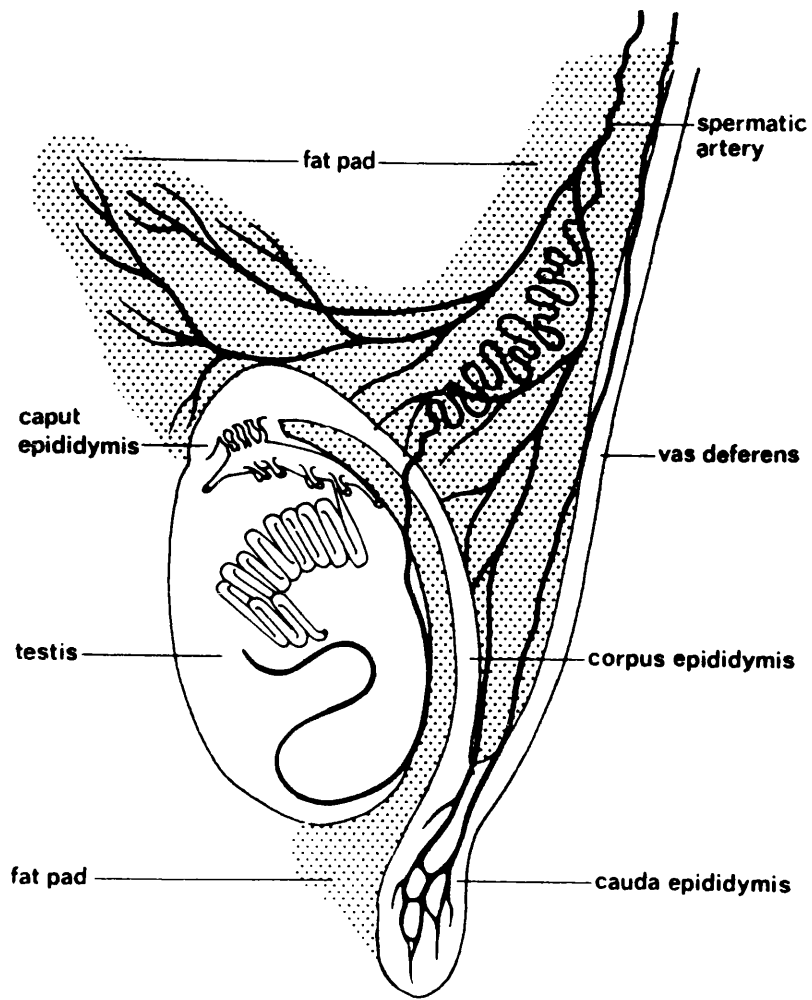


Figure 1.1

tubules are the compartments for sperm production. The number, length and diameter of the tubules differ between the species of animal, in the rat each tubule is about 1m in length with a diameter of 200-250 $\mu$ m and number about 30 tubules per testis. The tubules are highly convoluted and tightly packed within the tunica albuginea. Both ends of the seminiferous tubules open into the rete testis through the short tubuli recti. Spermatozoa from all the tubules have to pass through the rete testis before entering the epididymis for further maturation into fertile sperm.

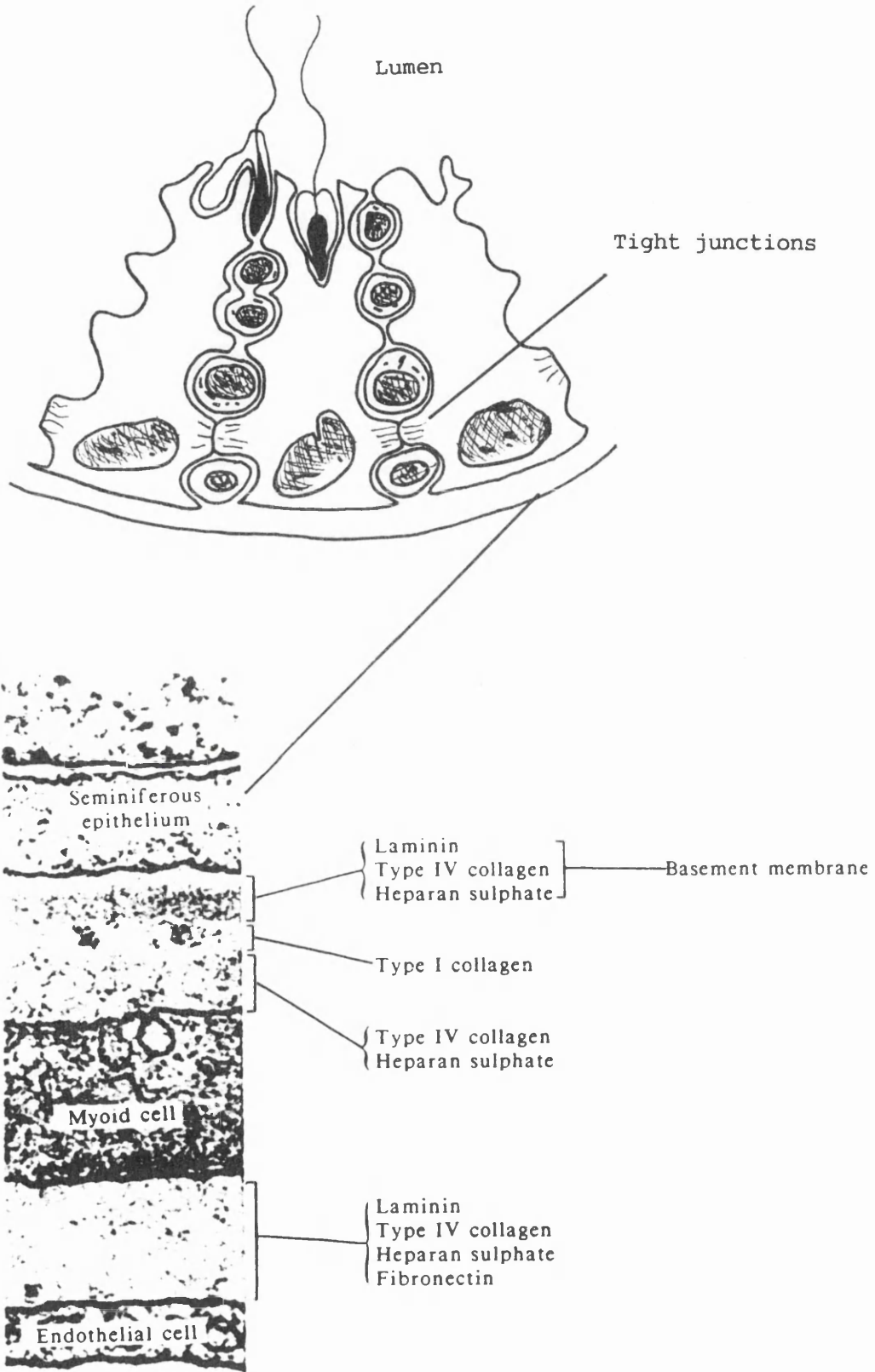
Within each tubule the developing germ cells mature towards the lumen, and are always in close association with Sertoli cells throughout development. From 3-dimensional studies it has been shown that each Sertoli cell is in contact with up to five other Sertoli cells at its base, and up to 47 germ cells at different stages of development (Skinner, 1991). This complex network of germ cell-Sertoli cells is surrounded by the lamina propria, which consists of a concentric arrangement of outer endothelial cells, myoid cells, seminiferous epithelium interspaced with extracellular tissue matrix (Fig. 1.2).

The Sertoli cell with its columnar and convoluted structure, regulates and provides physical and nutritional support for the development of spermatozoa from spermatogonia. An important feature of Sertoli cells is the junctional specializations formed with other cells, such as the tight junctions their base with adjacent Sertoli cells. These tight junctions exclude the passage of macromolecules from the interstitial space to the lumen of the seminiferous tubules. This is often referred to as the "blood-testis" barrier, and is essential in the maintenance of the unique microenvironment required for germ cell development (Skinner, 1980).

One feature of the seminiferous tubules is that the different cells in any cross-

**Fig. 1.2. The structure and cellular associations of the seminiferous tubule.** The top diagram shows developing germ cells maturing towards the lumen of the seminiferous tubule supported by adjacent Sertoli cells. Note the tight junctions at the base of the Sertoli cells, these are responsible for maintaining the blood-testis barrier. The lower shows the structure and composition of the tubular wall, known as the lamina propria, on which the Sertoli cells rest. x7800. (Adapted from Hadley & Dym, 1987 and Skinner, 1991).

Figure 1.2



section always form one of a number of constant associations (Fig. 1.3). The various generations of spermatocytes and spermatids derived from individual spermatogonia initiate waves of spermatogenesis that occur in a specific cyclic manner referred to as stages. The time taken for the same stage to reappear is constant for each species and ranges from 8 to 16 days, for the rat it is 12.8 days. A cross-section of the rat testis at any point will reveal adjacent tubules at different stages of the spermatogenic cycle (Fig. 1.4). This radial distribution of the spermatogenic cycle is found in most mammals. However, in man and one or two primates, the stages of the cycle follow a spiral within the seminiferous tubule (Sharpe, 1990).

A cross-section through a testis (Fig. 1.4) is dominated by the seminiferous tubules. In the spaces between adjacent tubules are the interstitial tissue of the testis, which consists of a framework of loose connective tissue that supports blood vessels and the interstitial cells (Leydig cells, macrophages and lymphocytes). The Leydig cells are the endocrine cells of the testis, and are responsible for the production of the male steroid hormone, testosterone. Testosterone is essential for spermatogenesis. The interstitial tissue is bathed in a protein-rich interstitial fluid, the volume of which can be altered via changes in the permeability of blood vessels within the interstitium (Maddocks & Sharpe, 1989).

**Fig. 1.3.** Schematic representation of the spermatogenic cycle in the adult rat to illustrate how each of the 14 stages (I-XIV) is characterized by the unique and fixed association of germ cell types. Each stage lasts for a fixed period of time and this varies from stage to stage (e.g. stage VII lasts for 62.8 hours, stage VIII for 21.3 hours and stage IX for only 7.1 hours). This is illustrated in the tubule segment in the diagram opposite in which the length of each stage has been drawn in proportion to its duration. Stages follow one another in sequence along the length of a tubule and, with the passage of time, germ cells in stage I will move to stage II, stage VI into stage VII, stage XIV into stage I, and so on. Testosterone is believed to act selectively at stage VII as judged from the observation that a small proportion of the germ cells at stage VII are the first to degenerate following testosterone withdrawal, whereas germ cells in stages VIII-XIV are affected at progressively later times. A<sub>1</sub>, A<sub>2</sub>, A<sub>3</sub>, A<sub>4</sub>, A-type spermatogonia; In, intermediate; B, B-type spermatogonia; Pl, preleptotene; L, leptotene; Z, zygotene; P, pachytene and Di, diplotene spermatocytes; II, secondary spermatocytes; 1-19, step 1 to 19 spermatids (step 19 spermatids are immature spermatozoa which are released into the tubule lumen at stage VIII and transported out of the testis to the epididymis). (Sharpe, 1990)

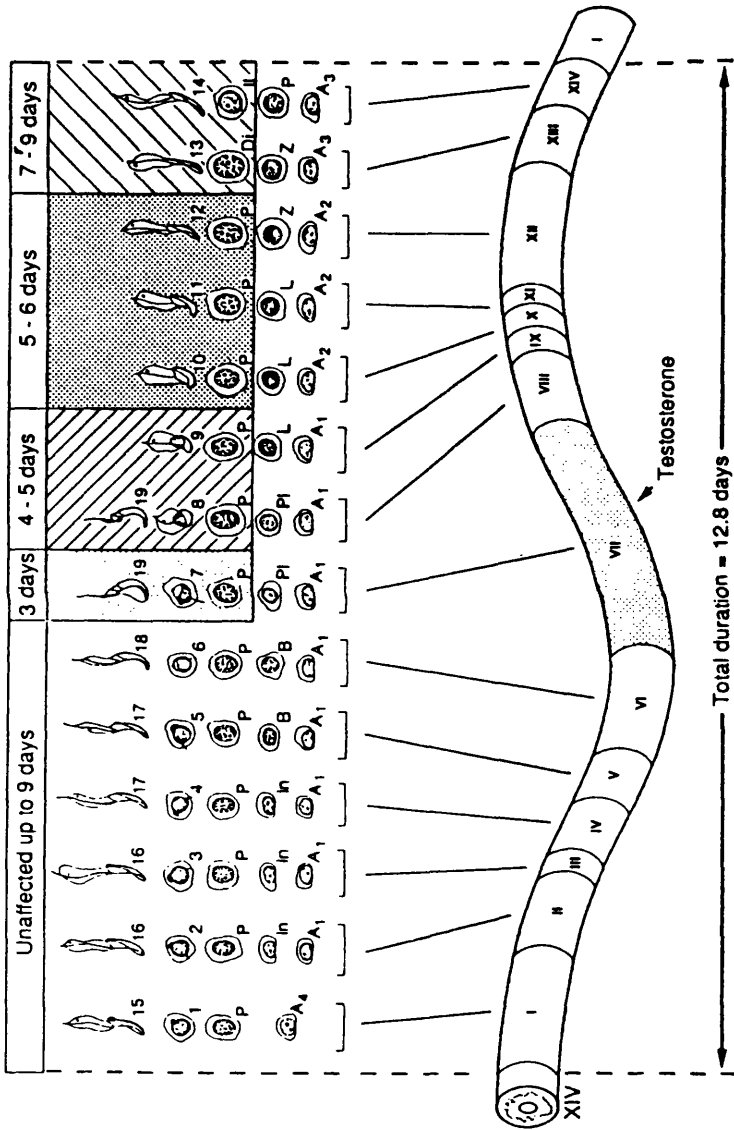


Figure 1.3

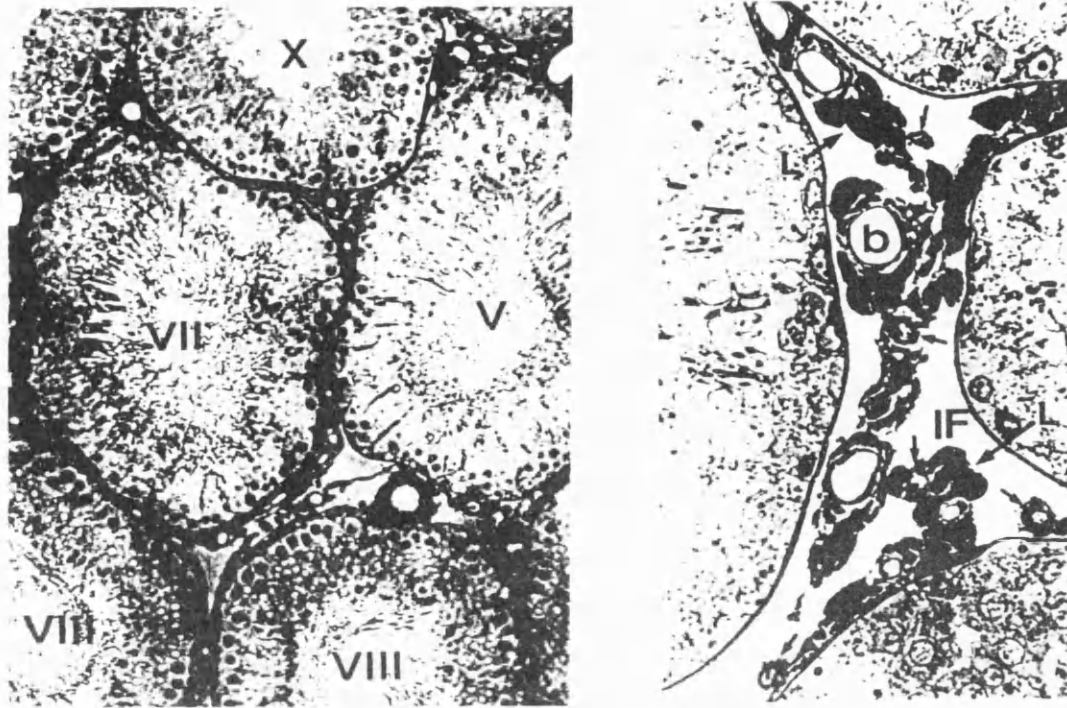


Fig. 1.4. Cross-section through a small area of an adult rat testis to illustrate how seminiferous tubules at different stages of the spermatogenic cycle are juxtaposed, with the interstitial areas between them. The latter is shown at higher magnification to the right and contains L, Leydig cell, b, blood vessels, macrophages (small arrows) and IF, interstitial fluid. Note the seminiferous tubules are packed with germ cells at various stages of development and note that the appearance of the tubules at different stages varies because of the different germ cell complement (see fig. 1.3), (Sharpe, 1990). Left x120; right x480.



## **1.2 Endocrine Control of Testicular Function**

Spermatogenesis is regulated by the pituitary glycoprotein-hormones, follicle-stimulating hormone (FSH) and luteinizing hormone (LH). The effect of FSH on spermatogenesis is mediated through FSH receptors on Sertoli cells, whilst LH acts through the stimulation of testosterone production by binding to LH receptors on Leydig cells. In the absence of FSH and testosterone, spermatogenesis is severely impaired.

### **1.2.1. The pituitary gland**

The pituitary gland is located at the base of the brain and it is central to the regulation of the endocrine system. The gland consists of two halves of different embryonic origin, the anterior pituitary (adenohypophysis) and the posterior pituitary (neurohypophysis). The adenohypophysis is derived from the buccal ectoderm and the neurohypophysis from the neural ectoderm (Fig. 1.5). This distinction plays an important role in the regulation of hormone release from these two regions. The neurohypophysis contains the nerve terminals of nerves originating from the supraoptic and paraventricular nuclei of the hypothalamus. These neurones secrete the peptide hormones, arginine vasopressin (AVP, antidiuretic hormone) and oxytocin, respectively. Therefore, these hormones are often referred to as hypothalamic rather than pituitary hormones.

The adenohypophysis releases six principal hormones into the systemic circulation. These include adrenocorticotropin (ACTH), growth hormone (somatotropin, GH), prolactin (PRL), thyroid-stimulating hormone (TSH) and the gonadotropin LH and FSH. The release of these hormones is under the control of hypothalamic neuronal secretions

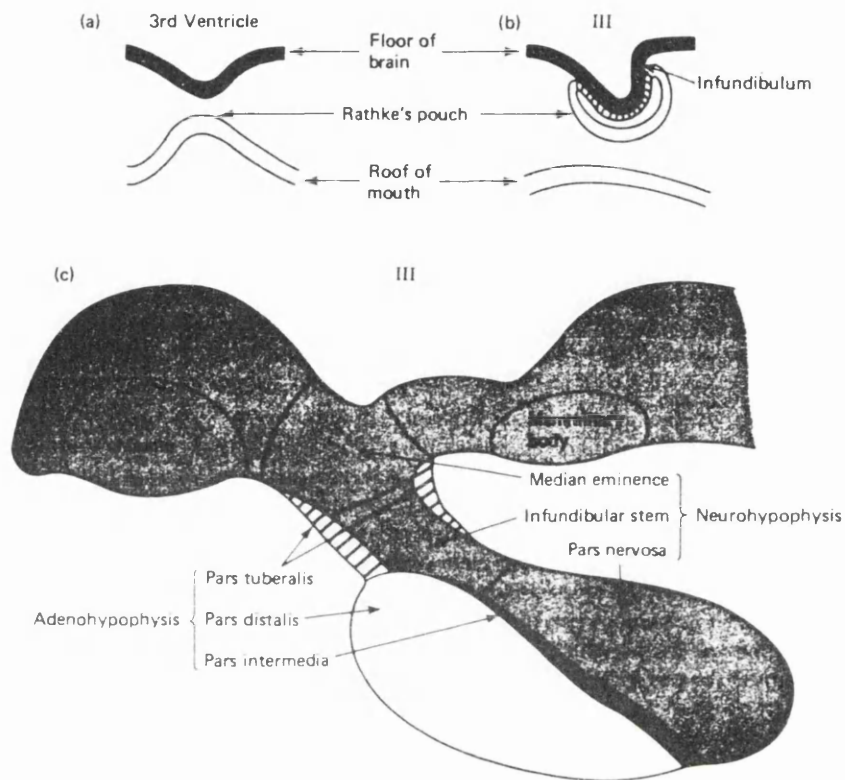


Fig. 1.5. Diagram to show the basic features of the development of the adeno- and neurohypophysis. (a) Early upgrowth of buccal ectoderm before Rathke's pouch has separated. (b) Rathke's pouch apposed to the infundibulum. (c) Typical mature pituitary gland. (Hardy, 1981)

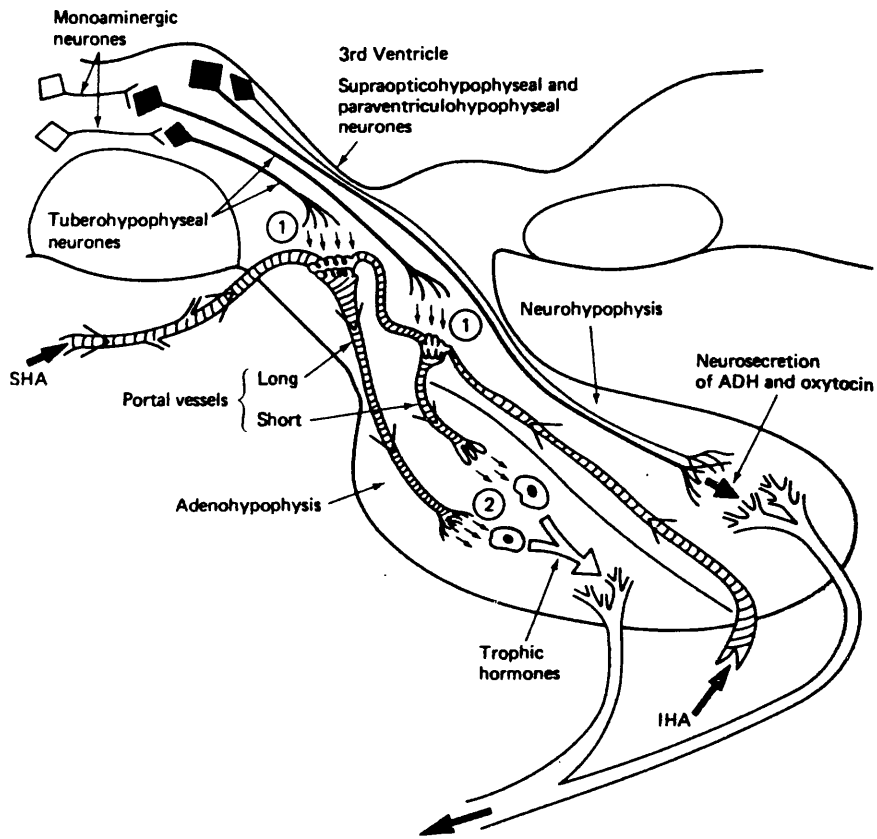


Fig. 1.6. Summary of the functional inter-relationships between hypothalamus and hypophysis. Hypophysiotrophic hormones enter the primary portal capillaries at (1) and leave these vessels to influence the adenohypophyseal cells at (2). IHA = inferior hypophyseal artery. SHA = superior hypophyseal artery. (Hardy, 1981)

into the hypophysial long and short portal veins that supply the adenohypophysis (Fig. 1.6).

### 1.2.2. Regulation of LH/FSH secretion

The control of gonadotrophin secretion from gonadotrophs (LH and FSH producing cells) is regulated by hypothalamic and systemic factors. The hypothalamus contains peptidergic neurones that produce a pulsatile secretion of gonadotrophin releasing hormone (GnRH) into the portal vessels of the adenohypophysis. The pulsatile release of GnRH is essential in maintaining the responsiveness of the gonadotrophs to GnRH (Huhtaniemi & Warren, 1990; Silman, 1991). The neurones that produce GnRH are not confined to a single nuclear group within the CNS but are widely scattered (Silverman & Gibson, 1990). The main sites of these neurones in the adult brain are in the septal-preoptic nuclei and the hypothalamus. It has recently been shown in fetal mice that GnRH neurones originate in the medial olfactory placode and enter the fore-brain with the nervous terminalis (Schmanzel-Fukuda and Pfaff, 1989). A failure of axonal and GnRH neuronal migration from the olfactory placode gives rise to Kallmann's syndrome. The sufferers of this syndrome have hypogonadotropic hypogonadism with anosmia (loss of ability to smell).

The pulsatile secretion of GnRH stimulates the gonadotrophs via specific GnRH receptors to release gonadotrophins. This response to hypothalamic GnRH is modified by the gonadal steroid hormones (testosterone, progesterone and oestradiol) in the systemic circulation, these inhibit gonadotrophin release via a negative feedback mechanism (Giguere et al., 1981; Tang et al., 1982; Kamel & Krey, 1983; Kamel &

Kubajak, 1988; Wierman et al., 1988). However, the steroid hormones also modulate the GnRH pulse-generator. The GnRH neurones do not possess steroid hormone receptors (Shiver et al, 1983). Therefore, steroid hormones exert their action through steroid-concentrating neurones that synapse with GnRH neurones (Hökfelt et al, 1987; Chronwall, 1989; Sar et al, 1990; Silverman & Gibson, 1990). The negative-feedback action of gonadal steroids has been shown to operate through a mechanism that involves the opioid peptides (Cicero et al, 1979, 1980; Drouva et al, 1981; Plant & Dubey, 1984; Adams et al, 1991).

The interaction between the hypothalamus, anterior pituitary and gonads is often referred to as the hypothalamic-pituitary-gonadal axis. This system allows gonadal function to be influenced by the external environment such as day length, which is particularly important for animals that are seasonal breeders. These rhythms in seasonal reproduction depend on the pineal gland as the interface between the photoperiodic variations and the GnRH pulse-generator. The pineal gland releases melatonin (N-acetyl-5-methoxy-tryptamine) during the night, such that during long winter nights the duration of melatonin release is increased. Increased melatonin levels have a negative effect on the GnRH pulse-generator, with a consequent loss of gonadotropin secretion from the anterior pituitary (for reviews see Reiter, 1991 and Silman, 1991).

Loss of secretory responsiveness in gonadotrophs occurs during exposure to continuous stimulation with high levels of GnRH. This agonist-induced desensitization is a characteristic feature of gonadotrophs (Smith & Vale, 1981). Development of GnRH-induced desensitization is not accounted for by receptor-down-regulation or gonadotropin depletion, but involves post-receptor mechanisms that are related to the signal transduction pathway. Studies on perfused gonadotrophs, with patch clamp

analysis of membrane  $\text{Ca}^{2+}$  currents, have demonstrated that prolonged or over exposure to GnRH attenuates the extracellular calcium-dependent  $\text{Ca}^{2+}$  signal and diminishes hormone secretion (Stojilkovic et al. 1989). The importance of the calcium-dependent signalling pathway in the secretion of gonadotropins has been extensively studied (for reviews see Catt & Stojilkovic, 1989; Davidson et al. 1991).

The GnRH-induced desensitization of gonadotropin secretion has provided a valuable therapeutic method for the suppression of gonadotropin secretion. Potent GnRH analogues (agonists and antagonists) have been synthesized (Karten & Rivier, 1986) and are in routine clinical use for the treatment of sex-steroid dependent tumours, such as cancer of the prostate. This pharmacological and reversible hypophysectomy (or chemical castration), combined with gonadotropins is also used in the induction of multiple follicular development (superovulation) in assisted conception programmes (Howles, 1990).

### 1.2.3. Structure of LH and FSH

The pituitary gonadotropins (LH & FSH) belong to the family of glycoprotein hormones, which also include thyroid-stimulating hormone (TSH), and chorionic gonadotropin (hCG) from the human placenta (hCG is similar to LH and will bind with high affinity to the same receptor). The glycoprotein hormones consist of two similar sized subunits held together by non-covalent forces, an  $\alpha$ -subunit that is common to all four, and a  $\beta$ -subunit that is specific to each. It has been shown that both subunits of the glycoprotein hormones are required for binding to their respective receptors, and it is the  $\beta$ -subunit that confers binding specificity (Pierce & Parsons, 1981). In the rat the mature

mRNA for the  $\alpha$ -subunit is translated into a precursor protein of 120 amino acids with a 24 amino acid leader peptide and an apoprotein of 96 amino acids. The rat LH $\beta$  and FSH $\beta$  mRNAs give rise to apoproteins of 121 and 110 amino acids, respectively. Between species there is 75-95% homology in the amino acid sequence of the  $\alpha$ -subunits, and 30-50% homology in the  $\beta$ -subunits (Wierman et al., 1988).

For a given species, the amino acid sequences of the  $\alpha$ -subunits are the same, although there may be differences in the carbohydrate moieties (Nilsson et al, 1986). These differences may be due to the influence of the different  $\beta$ -subunits, because processing to complex carbohydrate chains occurs only after subunit combination is completed (Magner & Weintraub, 1982). The importance of carbohydrate chains in the biological action of LH and hCG have been extensively studied, and shown to be essential for normal function (Channing et al, 1978; Chen et al., 1982; Goverman et al., 1982; Manjunath & Sairam, 1982; Sairam & Manjunath, 1983; Wang et al., 1989).

The different  $\beta$ -subunits are encoded by separate genes, while there is a single gene for the  $\alpha$ -subunit for all of the glycoprotein hormones in a particular species (Parsons et al., 1985; Strickland et al., 1985; Wierman et al., 1988). It appears that the production of the  $\beta$ -subunit is the rate-limiting step in glycoprotein hormone production, since the free  $\alpha$ -subunit is always found in excess (Parsons et al, 1983; Cole et al, 1984). In pituitary gonadotrophs, GnRH may be an absolute requirement for the induction of  $\beta$ -subunit production, since anencephalic fetuses have only the  $\alpha$ -subunit in their pituitary (Kaplan et al, 1976; Mulchaney et al. 1987; Huhtaniemi and Warren, 1990). For a review on the structure and regulation of the gonadotrophin subunit genes see Wierman et al., 1988.

#### 1.2.4. Structure of glycoprotein hormone receptors - exemplified by the LH receptor.

The water soluble glycoprotein hormones exert their action via binding to specific plasma membrane receptors. These receptors have recently been cloned and functionally expressed in various mammalian cell lines. The first to be cloned were the LH receptors from rat ovaries (McFarland et al., 1989) and porcine testis (Loosfelt et al., 1989). This was followed by the cloning of the TSH receptor (Libert et al., 1989; Nagayama et al., 1989; Parmentier et al., 1989; Misrahi et al., 1990) and then the FSH receptor (Sprengel et al., 1990). The human LH/hCG receptor has also been cloned (Minegishi et al., 1990) and shown to be highly homologous to the rat/porcine LH receptor. From the predicted amino acid sequences it was deduced that these receptors possessed seven transmembrane domains, and therefore belonged to the family of G-protein coupled receptors (Fig. 1.7). This was confirmation of previous biochemical studies, which have shown these receptors to be coupled to G-proteins (Cooke, 1983).

In spite of the structural and functional similarities with other G-protein coupled receptors, the receptors for glycoprotein hormones have several distinctive features. They are approximately twice the size of other cloned G-protein coupled receptors, and possess a large N-terminal extracellular domain (approximately 340 amino acids) that is N-glycosylated (six N-glycosylation sites on the LH receptor and three on the FSH receptor). For the LH receptor this extracellular domain accounts for approximately half of the polypeptide chain, and by itself will bind  $^{125}\text{I}$ -hCG with a high affinity, comparable to that of the full-length receptor (Xie et al., 1990). This is consistent with previous biochemical data suggesting that the LH/hCG receptor has a large 65 kDa extracellular domain, which can be proteolytically released from rat luteal membranes, and when



**Fig. 1.7.** Postulated topology of the LH/CG receptor in plasma membrane. Amino acids that are identical between the rat luteal (McFarland et al., 1989) and the porcine testicular (Loosfelt et al., 1989) LH/CG receptors are enclosed in circles. Those enclosed in squares are unique to the rat luteal receptor. Amino acids in barrels correspond to the putative transmembrane regions. Those amino acids above the barrels being extracellular. Those below the barrels being intracellular. Potential sites for N-linked glycosylation in the extracellular region are denoted by (Y). A potential disulphide bond between the first and the second extracellular loop regions is noted by the dashed line. Potential intracellular sites for phosphorylation are denoted by asterisks (serines and threonines) or dots (tyrosines). The two arrows in the cytoplasmic tail point to two clusters of basic amino acids which might represent potential tryptic cleavage sites. (from Segaloff et al., 1990)

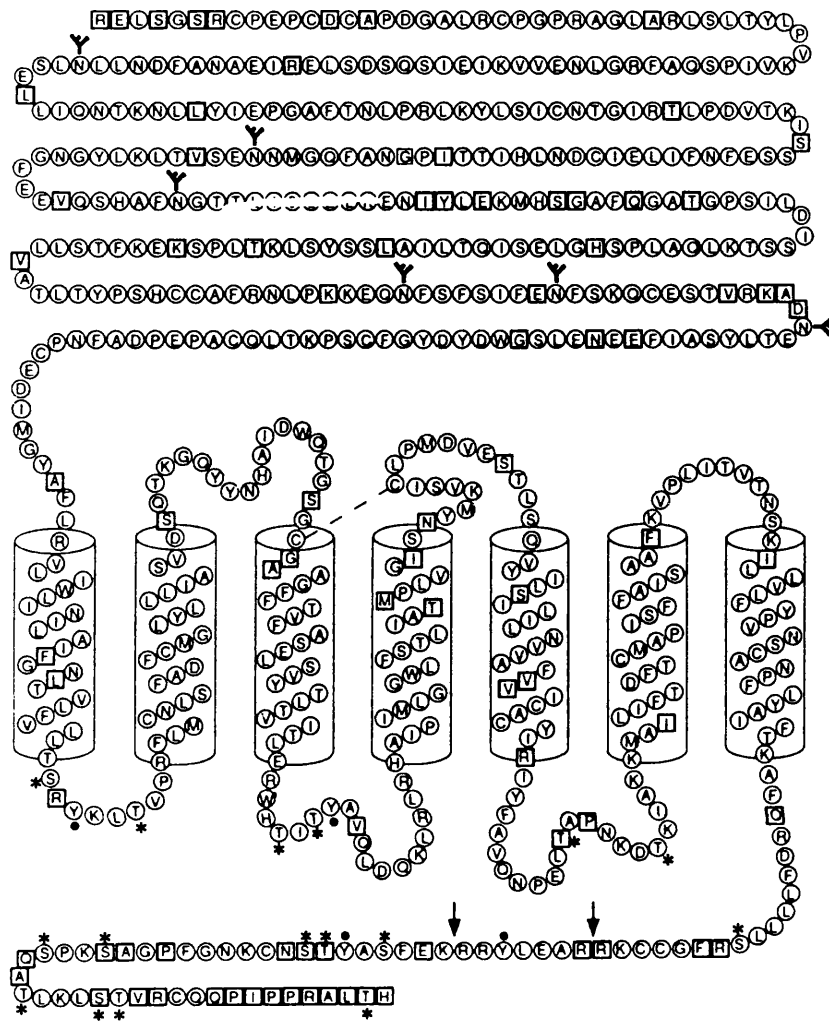


Figure 1.7

resolved by SDS polyacrylamide gel electrophoresis and transferred to nitrocellulose specifically binds  $^{125}\text{I}$ -hCG (Keinanen and Rajaniemi, 1986). The other G-protein coupled receptors that have been cloned do not possess a large extracellular domain (rhodopsin - Nathans and Hogness, 1983; yeast mating factors - Nakayama et al., 1985;  $\beta$ -adrenergic - Dixon et al., 1986; muscarinic acetylcholine - Kubo et al., 1986; substance-K - Masu et al., 1987;  $\alpha$ -adrenergic - Kobilka et al., 1987; serotonin - Julius et al., 1988; dopamine - Bunzow et al., 1988; angiotensin - Jackson et al., 1988; substance P - Yokoda et al., 1989; neuromedin K - Shigemoto et al., 1989) (Fig. 1.8).

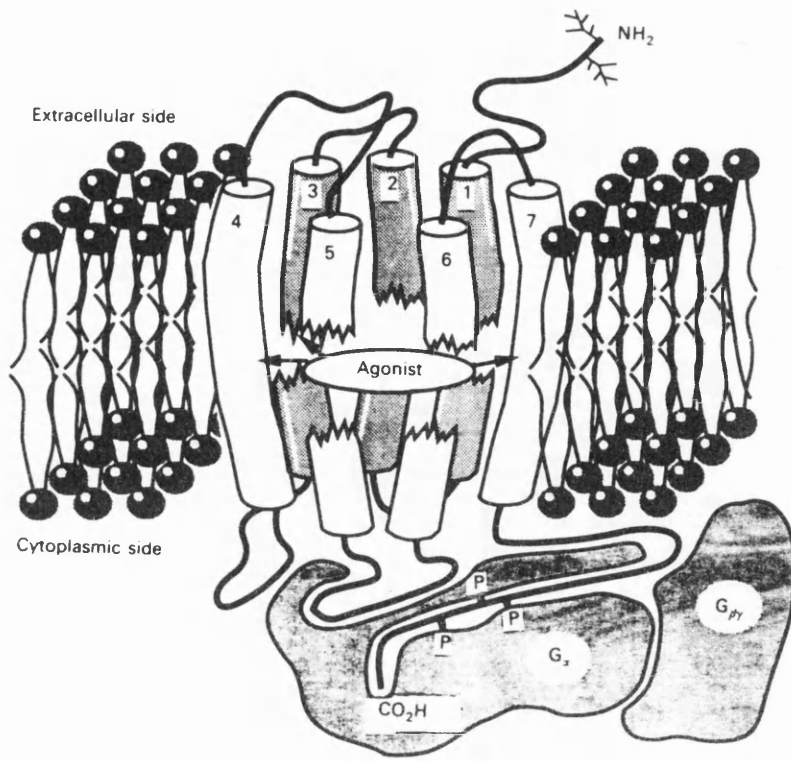
The C-terminal half of molecule which includes the seven transmembrane domains are essentially equivalent in size to the entire molecule of other G-protein coupled receptors e.g. rhodopsin and adrenergic receptors (Nathans and Hogness, 1983; Lefkowitz and Caron, 1988). In adrenergic receptors, an extended third cytoplasmic loop seems to be required for specific interactions with the G-protein (Kobilka et al., 1988; O'Dowd et al., 1989; Strader et al., 1989). However, the LH receptor does not appear to have an extended third cytoplasmic loop, or significant sequence homology with the  $\beta$ -adrenergic receptor's G-protein-coupling domain (McFarland et al., 1989; Loosfelt et al., 1989).

The glycoprotein hormone receptors appear to form a subfamily of G-protein coupled receptors. Their predicted structure suggest that the mechanism of translation of hormone binding to G-protein coupling is different from other G-protein coupled receptors whose ligands are much smaller and intercalate among the membrane helices (Fig. 1.8) (Segaloff et al., 1990; Tsai-Morris et al., 1990; Xie et al., 1990). This difference has been suggested by previous receptor binding studies, which have established that glycoprotein hormones bind to their receptors in a manner which is not

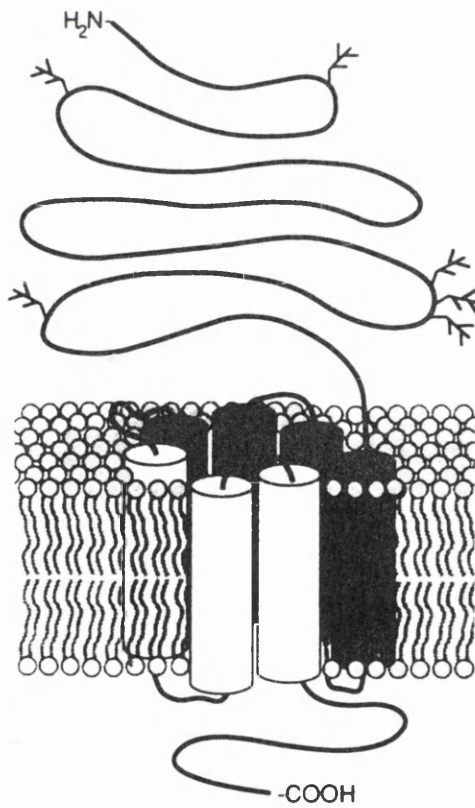
**Fig. 1.8. (a)** The model illustrates some of the features predicted to be shared by all receptors that interact directly with G proteins. The seven transmembrane helices are proposed to form the ligand-binding pocket. The intracellular C-terminal tail possess several serine and threonine residues that may be phosphorylated. Some of the regions of the receptor proposed to interact with G proteins are also shown. (Taylor, 1990) **(b)** This is the proposed model for the glycoprotein hormone receptors showing the large extracellular N-terminal domain. This is also the ligand-binding domain, although there could be possible interactions between the ligand and the seven-transmembrane domain. The mechanism of G protein binding is probably different from that proposed for other seven-transmembrane receptors. (McFarland et al, 1989).

Figure 1.8

(a)



(b)



readily reversible and are unaffected by guanine nucleotides in terms of their binding affinity. The other established G-protein coupled receptors are all affected by guanine nucleotides in their ligand binding affinities, and ligand binding is readily reversible (Abramowitz et al., 1981; Cooke, 1983). Further support comes from the finding that the extracellular domain of the LH receptor, by itself, can bind  $^{125}\text{I}$ -hCG with high affinity (Keinanen and Rajaniemi, 1986; Tsai-Morris et al., 1990; Xie et al., 1990).

The cloning of the LH receptor has greatly accelerated research into the regulation of the glycoprotein hormone receptors. This should allow new insights into the mechanism of receptor mediated G-protein activation.

The gene for the LH receptor has been isolated and the coding region has been shown to span 60kb and consists of 11 exons and 10 introns. The first 10 exons encode the N-terminal extracellular domain of the molecule. Exon 11 encodes the C-terminal half of the molecule which includes the seven transmembrane domains, the entire C-terminal cytoplasmic domain, and a 47-amino acid extracellular segment oriented toward the N-terminus. The 11th exon is similar in size to the intronless gene of the  $\beta$ -adrenergic receptor (Koo et al., 1991).

Despite the similarity in size between the 11th exon and the  $\beta$ -adrenergic-type receptors, there are distinct differences. The glycoprotein hormone receptors lack the consensus phosphorylation site RRXS/T for protein kinase-A that is found in the cytoplasmic domains of the  $\beta$ -adrenergic-type receptors (Taylor et al., 1990). However, there is a potential phosphorylation site for protein kinase-C (RRKEFS) in the cytoplasmic domain, which may be involved in receptor desensitization. This is supported by the ability of phorbol esters, known activators of protein kinase-C, to induce desensitization of the LH receptor (Cooke et al., 1990).

The presence of 10 introns in the LH receptor gene, would suggest the potential expression of variant mRNAs produced by the process of alternate splicing. This is supported by the finding of truncated forms of the receptor that lacked the transmembrane domains (Loosfelt et al., 1989; Tsai-Morris et al., 1990). These variants constitute a significant portion (40%) of LH receptor mRNA and may have a physiological role, by coding for secretory proteins which compete with the LH receptor for free hormone (Koo et al., 1991).

### **1.3 Regulation of testosterone production in Leydig cells by luteinizing hormone**

Testosterone is a steroid hormone and is central to male reproduction (for a review on the function of testosterone and its metabolites see Mainwaring et al., 1988). It is well established that Leydig cells are the site of testosterone synthesis, and this is under the regulation of LH. This section will deal with the various aspects of steroidogenesis in Leydig cells, including the steroid biosynthetic pathway, the source of cholesterol for steroid production, and the cellular mechanisms which mediate the stimulatory actions of LH.

#### **1.3.1. Conversion of cholesterol to testosterone**

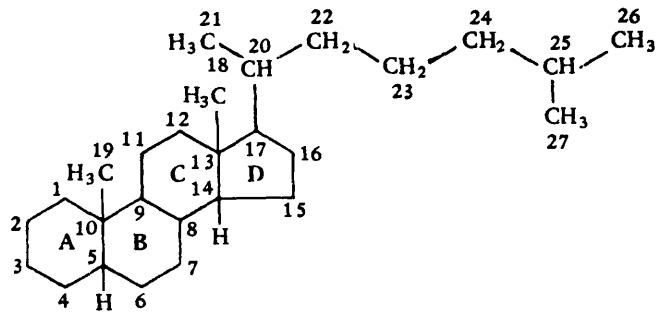
The initial step in steroid hormone biosynthesis is the formation of pregnenolone through the side-chain cleavage of cholesterol (Fig. 1.9). This reaction takes place in mitochondria and requires three distinct proteins, and utilizes three molecules of

**Fig. 1.9.** (a) Shows the numbering of the carbon atoms in the steroid molecule. (b) Biosynthesis of pregnenolone from cholesterol, catalyzed by the cholesterol side-chain cleavage cytochrome P-450 (P-450<sub>scc</sub>) enzyme system. (Schulster et al., 1976)

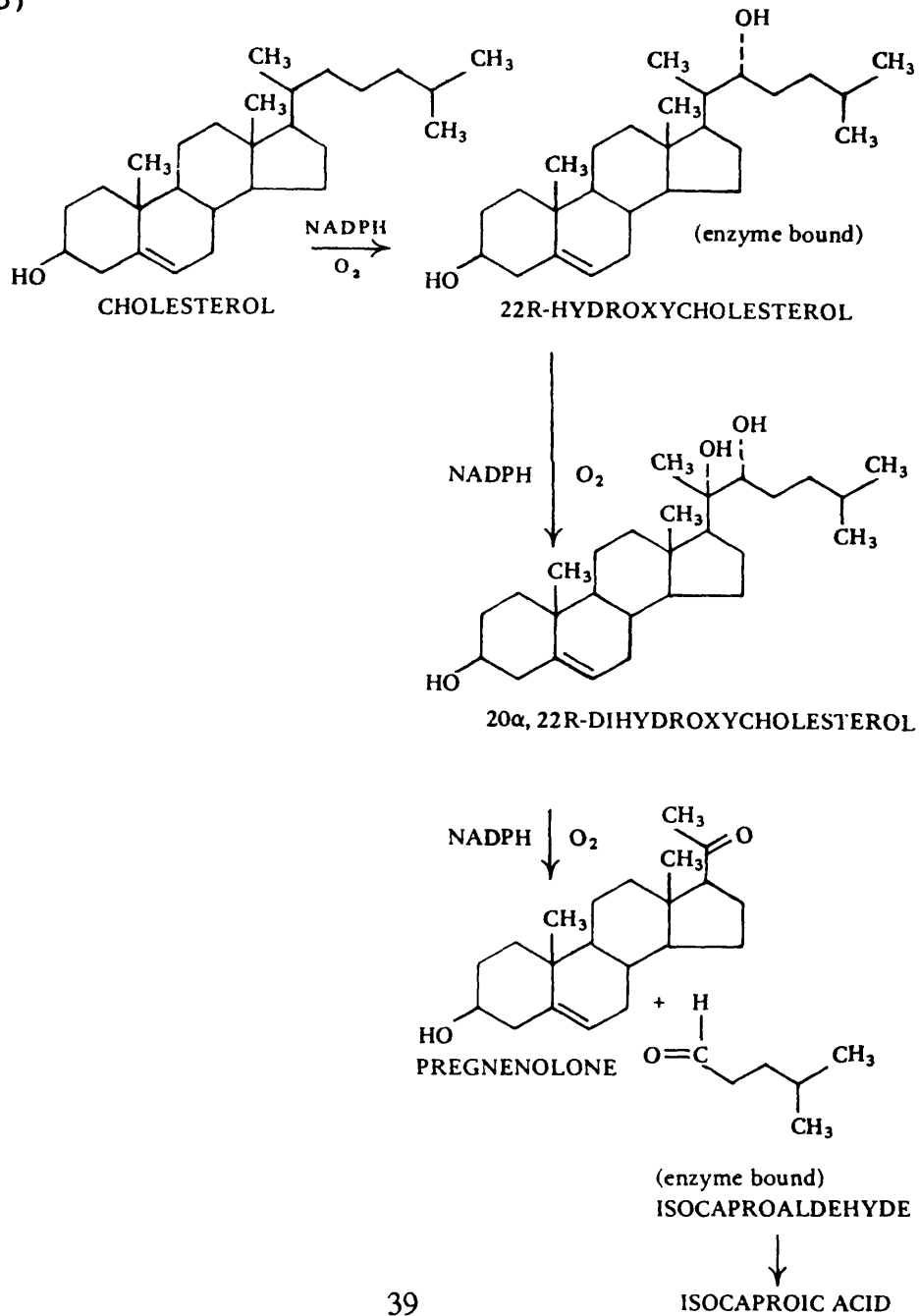


Figure 1.9

(a)



(b)



molecular oxygen and three molecules of NADPH; the first two are for the sequential hydrogenation of carbon 22 and 20. The third molecule of oxygen is required for cleavage of the carbon-carbon bond between these two atoms. The reducing equivalents from mitochondrial NADPH are transferred by a flavoprotein (adrenodoxin reductase) to an iron-sulphur protein (adrenodoxin). These enzymes are localized in the mitochondrial matrix. Adrenodoxin transfers electrons to a specific form of cytochrome P-450, cholesterol side-chain cleavage cytochrome P-450 (P-450<sub>sc</sub>), localized in the inner aspect of the inner mitochondrial membrane (Simpson and Waterman, 1988; Gower, 1988).

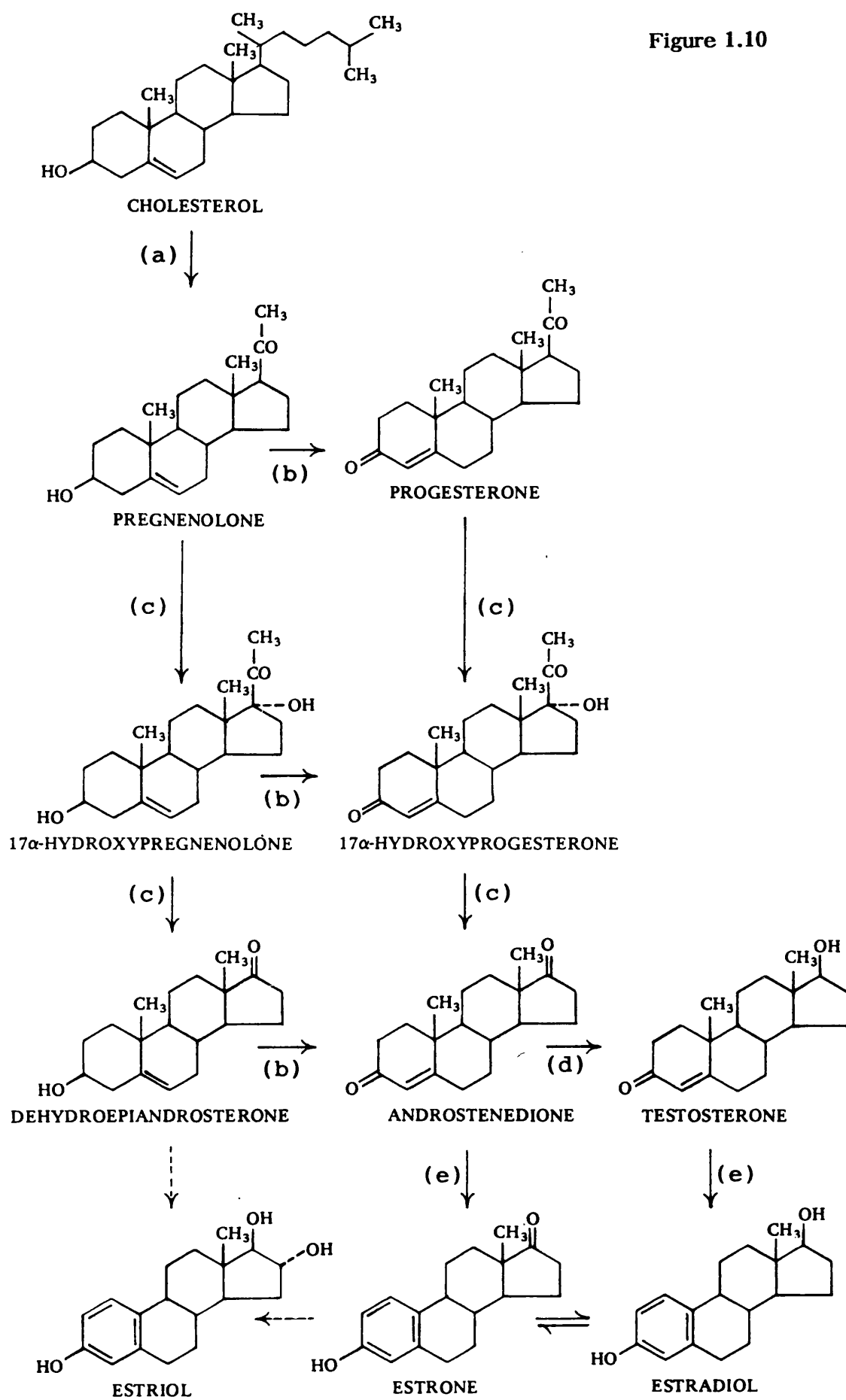
The conversion of pregnenolone to testosterone is catalyzed by non-mitochondrial enzymes. These enzymes are located in the smooth endoplasmic reticulum, and include the 5-ene-3 $\beta$ -hydroxysteroid/3-oxosteroid-4,5-isomerase (5-ene-3 $\beta$ -HSD/4,5-isomerase), cytochrome P-450 17 $\alpha$ -hydroxylase/17,20-lyase (P-450<sub>17 $\alpha$</sub> ), and 17 $\beta$ -hydroxysteroid dehydrogenase (17 $\beta$ -HSD). From the action of these enzymes, two pathways for testosterone synthesis are recognized (Fig. 1.10). One involving 5-ene-3 $\beta$ -hydroxysteroids ("delta-5" pathway), the other involving 4-ene-oxosteroids ("delta-4" pathway). The delta-5 steroids can enter the delta-4 pathway via the 5-ene-3 $\beta$ -HSD/isomerase enzyme system, but the reverse reactions occur to only a very limited extent. The relative importance of these two pathways show considerable variation between species. In the rat and mouse testis the delta-4 pathway predominates, whereas in human testis the delta-5 pathway is more important (for review see Gower, 1988).

The production of C<sub>19</sub> steroids from C<sub>21</sub> precursors is dependent on the activity of P-450<sub>17 $\alpha$</sub> , which catalyze the 17 $\alpha$ -hydroxylation of pregnenolone and progesterone to give 17 $\alpha$ -hydroxypregnenolone and 17 $\alpha$ -hydroxyprogesterone, followed by the cleavage of the

**Fig. 1.10.** Shows the biosynthesis of male and female steroid hormones from cholesterol.

The enzymes involved in each step are the following :- (a) cytochrome P-450<sub>sc</sub> (b) 5-ene-3 $\beta$ -hydroxysteroid/3-oxosteroid-4,5-isomerase (c) cytochrome P-450 17 $\alpha$ -hydroxylase/17,20-lyase (d) 17 $\beta$ -hydroxysteroid dehydrogenase (e) cytochrome P-450 aromatase. (Adapted from Schulster et al., 1976)

Figure 1.10



C-17,20 carbon bond via the 17,20-lyase reaction to yield dehydroepiandrosterone (DHEA) and 4-androstenedione, respectively (Yanase et al., 1991). From the result of cloning and subsequent expression of cDNA clones from the rat, bovine and human P-450<sub>17 $\alpha$</sub> , both the 17 $\alpha$ -hydroxylase and 17,20-lyase reactions have been shown to be catalyzed by a single polypeptide. However, while rat P-450<sub>17 $\alpha$</sub>  can catalyze both the conversion of 17 $\alpha$ -hydroxypregnenolone and 17 $\alpha$ -hydroxyprogesterone to their respective C<sub>19</sub> steroids, bovine and human P-450<sub>17 $\alpha$</sub>  can convert only 17 $\alpha$ -hydroxypregnenolone to DHEA (Fevold et al., 1989). This could explain the predominance of the delta-5 pathway in the production of testosterone in human Leydig cells.

From investigations into the hormonal regulation of steroidogenic enzymes, the maintenance of P-450<sub>17 $\alpha$</sub>  activity was found to be completely dependent on trophic hormone stimulation (Simpson and Waterman, 1988; Payne, 1990; Yanase et al, 1991). In primary cultures of mouse Leydig cells and bovine adrenal cortical cells, synthesis of P-450<sub>17 $\alpha$</sub>  was undetectable in the absence of LH/hCG and ACTH, respectively. The enzyme levels could also be maintained with analogues of cyclic AMP, an established second messenger of the trophic hormones. This absolute requirement for cyclic AMP stimulation has not been found for other steroidogenic enzymes (Simpson and Waterman, 1988; Payne, 1990). For example, the first enzyme in the steroidogenic pathway, P-450<sub>scc</sub>, showed constitutive synthesis, although its levels could be increased by cyclic AMP. However, it should be pointed out that the activity of P-450<sub>17 $\alpha$</sub>  in freshly isolated cells is sufficient to maintain maximum production of testosterone, and it has been demonstrated that the activity of P-450<sub>17 $\alpha$</sub>  becomes limiting only when it is reduced to less than 10% of the normal level (Anakwe and Payne, 1987).

The induction of P-450<sub>17 $\alpha$</sub>  mRNA and other steroidogenic cytochrome P-450s

requires hours and is prevented by the protein synthesis inhibitor, cycloheximide. This indicates that the regulation of expression of steroidogenic enzyme genes by cyclic AMP requires the mediation of some short-lived protein factor(s). The nature of these transcriptional activators have yet to be elucidated, and is an area of on-going research (Simpson and Waterman, 1988; Payne, 1990).

The balance of intermediates in the above steroidogenic pathway is determined by the individual enzyme activities and specificities. Once these intermediates are formed, they can readily diffuse out of the cell and enter into the blood circulation. Therefore, the regulation of the relative activities of the steroidogenic enzymes are important not only to the production of testosterone, but also for the production of steroid intermediates, which may have important physiological effects. In the case of pregnenolone and progesterone, these can be further metabolized by the adrenals and other tissues. It has been demonstrated that metabolites of progesterone and pregnenolone ( $5\alpha$ -pregnane- $3\alpha$ -ol-20-one and pregnenolone sulphate, respectively) can bind to and directly modulate GABA<sub>A</sub> receptors in the CNS (for review see Lambert et al., 1987). More recently it was shown that progesterone and  $17\alpha$ -hydroxyprogesterone, but not other steroids, could stimulate calcium influx in human sperm (Blackmore et al., 1990). The existence of non-classical cell-surface steroid effects are increasingly being found, but this area of research is still in its infancy. For information on the metabolism of steroids and other steroidogenic tissues, see Schulster et al, 1976; Gower, 1979; Gower, 1988.

### 1.3.2. The supply of cholesterol for testosterone production

There are three potential sources of cholesterol for acute testosterone production. These include cellular cholesterol stores, de novo synthesis and uptake of lipoprotein-derived cholesterol. The importance of lipoprotein cholesterol in steroidogenesis has been extensively reviewed (Gwynne and Strauss III., 1982), and is of major importance in the adrenal and ovary. However, in the testis, cholesterol for steroidogenesis comes mainly from de novo synthesis (Morris and Chaikoff, 1959; Charreau et al., 1981; Hou et al., 1990). It was demonstrated that the depletion of lipoprotein cholesterol (hypocholesterolemic) had no inhibitory effect on testosterone production. Furthermore, the activity of hydroxymethylglutaryl coenzyme A (HMG-CoA) reductase, the rate-limiting enzyme in cholesterol synthesis (for reviews see Luskey, 1988; Goldstein and Brown, 1990), was not increased in Leydig cells isolated from these hypocholesterolemic rats.

It has been demonstrated in Chinese hamster ovary (CHO) cells that newly synthesized cholesterol is transported, probably via vesicular transport, to the plasma membrane through an energy dependent process (Kaplan and Simoni, 1985). Further studies in mouse (MA10) Leydig tumour cells showed that the plasma membrane was the major source of steroidogenic cholesterol, and suggested that under hormone-stimulation newly synthesized cholesterol was diverted from incorporation into the plasma membrane and directed into the steroidogenic pathway (Freeman, 1987, 1989). However, it was found that these changes in cholesterol transport could be blocked by preventing the utilization of cholesterol for steroidogenesis with aminoglutethimide. This finding suggested that changes in cholesterol transport was not the cause of steroidogenesis, but

rather a direct consequence of cholesterol utilization.

It was later shown that agents such as cytochalasin-D and colchicine, that disrupt the cytoskeleton, inhibited the internalization of plasma membrane cholesterol and steroidogenesis at the same concentrations (Nagy and Freeman, 1990). The importance of the cytoskeleton in steroidogenesis is well recognized (for review see Hall, 1985), but the above findings show that the changes in the synthesis and transport of cholesterol is not the primary effect of LH-stimulation in Leydig cells.

While the P-450<sub>sc</sub> enzyme activity is responsible for the conversion of cholesterol to pregnenolone, the acute production of steroids is limited by the rate of transport of cholesterol to the enzyme complex (Simpson, 1979; Privalle et al., 1983). This conclusion is based on the observation that even in cells stimulated maximally, the enzyme is not functioning at its full catalytic capacity. It has now been established that the rate-limiting step in steroidogenesis, in all steroidogenic tissues, is the transport of cholesterol from the outer to the inner membrane of the mitochondria. This process requires the translation of short half-life protein(s), and is acutely sensitive to inhibitors of protein translation such as cycloheximide, and possess a half-life of less than 13 min (Hall and Eik-Nes, 1962; Ferguson, 1963; Garren et al., 1965; Shin, 1967; Hermier et al., 1971; Moyle et al., 1971; Cooke et al., 1975; Privalle et al., 1983).

Since those early investigations, a number of studies have attempted to determine the nature of the proteins synthesized in response to hormone stimulation and to determine their mechanism of action in regulating steroid production. This has led to the discovery and isolation of a number of protein candidates for the elusive regulatory protein of steroidogenesis (for a critical review see Strott, 1990). These include the sterol carrier protein-2 (SCP<sub>2</sub>) (Vahouny et al, 1983; 1984), steroidogenesis activator



protein (SAP) (Pedersen and Brownie, 1987) and the 8.2 K protein (Yanagibashi, 1988). The three proteins are structurally distinct and widely distributed in steroidogenic and non-steroidogenic tissues. When these proteins are added to mitochondria isolated from steroidogenic tissues, they all stimulate the transfer of cholesterol from the outer to inner mitochondrial membrane, and the production of pregnenolone. However, none of these proteins will stimulate the production of pregnenolone to the levels achieved with the trophic hormones, this questions their role as *the* rate-limiting regulators of steroidogenesis.

Of these proposed rate-limiting proteins, SAP (Mertz and Pedersen, 1989) is the only protein that has been shown to possess a short half-life (5-7 min) in response to cycloheximide treatment. These workers demonstrated an increase in SAP in response to stimulation with ACTH (1nM) and 8-bromo cyclic AMP (1mM), in rat adrenocortical cells, which reached half-maximal and maximal (16-fold greater than basal) levels at 3 and 15 min, respectively. The levels of intracellular SAP content and of corticosterone output also exhibited a similar dose-response to ACTH ( $EC_{50}$  of 25, 30pM, respectively).

In contrast, both the SCP<sub>2</sub> and 8.2K protein possess long half-lives and are cycloheximide-insensitive. However, these proteins may still play an important role in the transport of cholesterol to the mitochondria *in vivo* as suggested by their presence in high concentrations in all steroidogenic tissues.

The 8.2K protein has been identified as an endozepine (Besman et al., 1989). Endozepines have been isolated from bovine, human and rat brains (Guidotti et al., 1983; Marquardt et al., 1986; Shoyab et al., 1986) and shown to displace the binding of [<sup>3</sup>H]-benzodiazepam to GABA<sub>A</sub> receptors, hence they are sometimes referred to as diazepam-binding inhibitors (DBI). More recently, it has been found that the reported sequence of

rat liver acyl-coenzyme-A-binding protein is identical to that of rat brain DBI (Knudsen et al., 1989). The physiological function of the endozepines appears to be diverse, acting as a neuro-regulator, acyl-coenzyme-A-binding protein and also binding to mitochondrial (peripheral) benzodiazepine receptors (MBR) (Besman et al., 1989).

The MBR is localized on the outer membrane of mitochondria in a wide variety of cells, but all steroidogenic tissues show a high density of [<sup>3</sup>H]-benzodiazepine binding (60 million sites/cell) (De Souza et al., 1985; Papadopoulos et al., 1990; Amsterdam and Suh., 1991). The role of MBR in steroidogenesis has been investigated using specific ligands to MBR (Ritta et al., 1987; Mukhin et al., 1989; Yanagibashi et al., 1989; Papadopoulos et al., 1990; Papadopoulos et al., 1991; Amsterdam and Suh., 1991). It was found that these ligands stimulated steroidogenesis in a cycloheximide-independent manner, but the level of stimulation was very low compared with those induced by trophic hormones. The importance of the 8.2K protein and its physiological receptor (MBR) in the regulation of steroidogenesis is still uncertain.

Another approach to the study of labile proteins involved in the stimulation of steroidogenesis has been the investigation of mitochondrial proteins that are synthesized in response to stimulation with trophic hormones (Ray et al., 1980; Dazord., 1981; Pon et al., 1986a, 1986b; Krueger et al., 1988; Stocco and Kilgore, 1988; Stocco and Chen, 1991). These workers have found the accumulation of several proteins in response to hormone-stimulation, which can be inhibited by cycloheximide. Recently, it was shown that R2C rat Leydig tumour cells which produce steroids constitutively, also show constitutive production of mitochondrial proteins (30kD proteins) that are cycloheximide-sensitive (Stocco and Chen, 1991). This finding gives strong support to the "labile-protein" theory for the hormone-stimulation of steroidogenesis.

From the above evidence it can be concluded that the search for the labile-protein(s) which regulates the first step of steroidogenesis is still on-going, even after almost three decades of research.

#### **1.4 Intracellular mechanisms mediating the action of LH in testis Leydig cells**

##### **1.4.1. The adenylate cyclase system**

It is well established that gonadotrophic hormones such as LH interact with their plasma membrane receptors to activate the adenylate system to form cyclic AMP (Cooke, 1983). However, LH may also directly activate other transducing systems (Rommerts and Cooke, 1988). These include arachidonic acid release and metabolism (Dix et al., 1984; Chaudry et al., 1989; Abayasekara et al., 1990), and modulation of intracellular free calcium (Janszen et al., 1976; Sullivan and Cooke., 1986).

The stimulatory effect of LH on the adenylate cyclase is mediated by the GTP binding protein  $G_s$ . Cholera toxin, which specifically activates  $G_s$  through ADP-ribosylation of the  $\alpha_s$  subunit (for an extensive review on G-proteins see Birnbaumer et al., 1990), increases cyclic AMP production and steroidogenesis in Leydig cells (Cooke et al., 1977; Dufau et al., 1978). The activation of the adenylate cyclase system by LH, cholera toxin and GTP analogues has been demonstrated in isolated plasma membranes from Leydig cells (reviewed in Cooke et al., 1990). This adenylate cyclase system, like those of other cell types (Birnbaumer et al., 1990), can be negatively regulated by the inhibitory GTP binding protein ( $G_i$ ). This was demonstrated by the use of pertussis toxin, which inactivates  $G_i$  through ADP-ribosylation of the  $\alpha_i$  subunit by the transfer of

an ADP-ribose from [<sup>32</sup>P]NAD (Platts et al., 1988). Evidence to support the involvement of G<sub>i</sub> was obtained from studies with cultured Leydig cells in which it was shown that the inhibitory effects of arginine vasopressin on steroidogenesis could be abolished by pertussis toxin (Adashi et al., 1984).

The coupling of the LH receptor to the G<sub>s</sub>/adenylate cyclase system can be inhibited (desensitized) through the repeated administration of the hormone (Cooke et al., 1990; Segaloff et al., 1990). This loss of response persists in plasma membranes prepared from desensitized cells (Dix et al., 1982). In rat Leydig cells the response to cholera toxin and GTP-analogues was not impaired, this indicated that the lesion was the coupling between the receptor and the G-protein. However, in mouse Leydig cells the desensitized membranes showed no response to cholera toxin and GTP-analogues, and desensitization could be mimicked by treatment of intact cells with cyclic AMP analogues (Schumacher et al., 1984). This demonstrated species differences in the mechanism of desensitization of the LH receptor. In the rat, LH-induced desensitization was found to be a cyclic AMP-independent process.

The pretreatment of Leydig cells with phorbol esters, which activate protein kinase C (PKC), has been shown to inhibit LH/hCG-stimulated cyclic AMP production (Mukhopadhyay and Schumacher, 1985; Themmen et al., 1986; Dix et al., 1987). This action of PKC may have a physiological function, since a potential PKC phosphorylation site has been found on the cytoplasmic domain of the LH-receptor (Loosfelt et al 1989; Koo et al., 1991). However, unlike LH-induced desensitization, pretreatment of rat Leydig cells with phorbol esters causes a potentiated response to cholera toxin. This effect may have been due to either a modification of G<sub>s</sub> such that its ability to stimulate the adenylate cyclase catalytic subunit was increased, or the inhibition of the action of G<sub>i</sub>.

The pretreatment of Leydig cells with pertussis toxin, potentiated both basal and LH-stimulated cyclic AMP production. In LH-desensitized cells pertussis toxin also potentiated the response of the cells to cholera toxin, but it did not reverse the LH-induced desensitization. In contrast, pertussis toxin pretreatment was not able to potentiate cholera toxin-stimulated cyclic AMP production in phorbol ester-desensitized cells. This suggested that one of the actions of phorbol esters was the inhibition  $G_i$  (Platts et al., 1988). The phosphorylation of  $G_i$  and attenuation of  $G_i$  activity by phorbol esters have also been found in other cell systems (Katada et al., 1985; Jakobs et al., 1985; Bell and Brunton, 1986; Sagi-Eisenberg, 1989). Fig. 1.11 shows a scheme for the proposed sites of action of phorbol ester-activated protein kinase C on the LH receptor-G-protein-adenylate cyclase transducing system.

The stimulation of cyclic AMP production in Leydig cells with LH can readily be demonstrated, and therefore has been studied extensively. However, there is increasing evidence that other intracellular/second messengers may be activated through the binding of LH to its receptor (Rommerts and Cooke, 1988). The search for other second messengers was prompted by the observation that at low concentrations of cholera toxin, cyclic AMP production is stimulated in purified Leydig cells without any detectable change in steroidogenesis (Cooke et al., 1977; Dufau et al., 1978). It was also found that in freshly isolated Leydig cells isoproterenol could stimulate a 10 fold increase in cyclic AMP without any change in steroid production, whereas LH stimulated steroid production more than 10 fold without any detectable change in cyclic AMP (Cooke et al., 1982). These discrepancies have been explained by some workers through the postulation of a functional compartmentalization of cyclic AMP action during hormone stimulation (Dufau, 1988).

**Fig. 1.11.** Scheme showing proposed sites of action of phorbol esters-activated protein kinase C on the LH receptor-G protein-adenylate cyclase transducing system. (Cooke et al., 1989)

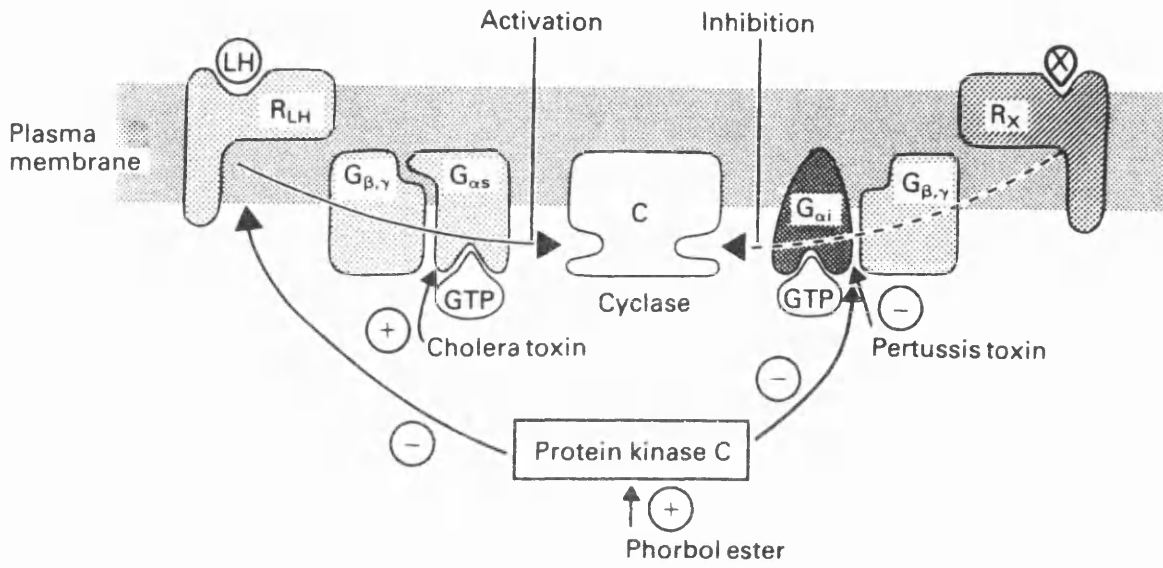


Figure 1.11

#### 1.4.2. The increase of intracellular calcium

Extracellular calcium has been shown to be required for maximum LH-stimulated steroidogenesis in isolated Leydig cells (Janszen et al., 1976; Sullivan and Cooke., 1986). Using percoll-purified Leydig cells loaded with the intracellular fluorescent indicator, Quin 2, it was shown that LH and cyclic AMP analogues could increase intracellular free calcium. When the calcium ionophore, A23187, was added to freshly isolated Leydig cells in culture there was no stimulation of LH-stimulated testosterone production (Sullivan and Cooke, 1984b), although cyclic AMP production was attenuated. However, the calcium ionophore did stimulate the basal production of testosterone, although the magnitude and the time-course of production lagged behind that for LH-stimulated testosterone production (Sullivan and Cooke, 1984a; 1985). These results indicate that calcium may play a positive role in the regulation of steroidogenesis in Leydig cells. The mechanisms which regulate intracellular free calcium in Leydig cells are not known.

In bovine luteal cells it has been shown that LH/hCG can activate inositol 1,4,5-trisphosphate (IP<sub>3</sub>) production (Davis et al., 1986; Davis et al., 1987); IP<sub>3</sub> production has been shown to be involved in calcium release from intracellular stores (Berridge and Irvine, 1984). The LH and cyclic AMP stimulated increase in the intracellular calcium of single bovine luteal cells have also been demonstrated using the fluorescent calcium chelator Fura-2 (Alila and Hansel, 1989). Although the presence of the arginine vasopressin (AVP) sensitive inositol phosphate/diacylglycerol pathway has been found in Leydig cells, the stimulation of this signal transduction system could not be demonstrated with LH/hCG (Ascoli et al., 1989).



### 1.4.3. The liberation and metabolism of arachidonic acid

Investigations into the effect of inhibitors of the cyclooxygenase and lipoxygenase pathways of arachidonic acid metabolism on steroidogenesis in rat testis Leydig cells, led to the finding that inhibition of the lipoxygenase activity but not cyclooxygenase activity caused an inhibition of LH- and dibutyryl cyclic AMP- stimulated steroid production (Dix et al., 1984). This suggested a role for products of the lipoxygenase pathway of arachidonic acid metabolism in steroidogenesis. The site of action for these metabolites was shown to be distal to the production of cyclic AMP and before the side chain cleavage of cholesterol. The possible involvement of arachidonic acid metabolites of the lipoxygenase pathway in steroidogenesis has also been confirmed from studies in adrenal cortical cells (Kojima et al., 1985; Solano et al., 1988), and a product of the 12-lipoxygenase pathway, 12-hydroxeicosatetraenoic acid (12-HETE), was shown to be able to reverse the effect of a lipoxygenase inhibitor (BW755C) on A-II stimulated aldosterone production (Nadler et al., 1987). More recently, a study into the metabolism of arachidonic acid by rat adrenal glomerulosa cells was carried out (Campbell et al., 1991), but the effects of hormone stimulation were not investigated.

The liberation of arachidonic acid from membrane phospholipids is generally accepted as the rate-limiting step in the formation of arachidonic acid metabolites (Wolfe, 1982; Irvine, 1982; Smith, 1989). The bulk of the arachidonic acid in mammalian cells is esterified to the sn-2 position of glycerophospholipids. The low level of arachidonic acid in the cytosol is thought to be due to the high activity of the enzyme(s) that transfer the arachidonate from arachidonoyl-CoA to phospholipids (Irvine, 1982). Arachidonic acid can be released from phospholipids by the action of phospholipase A<sub>2</sub> (PLA<sub>2</sub>) or

phospholipase C (PLC) and diacylglycerol lipase. The action of PLC is particularly important in cells that are regulated via the hydrolysis of phosphatidylinositol 4,5-bisphosphate located in the inner leaflet of the plasma membrane. The activation of PLC leads to the formation of diacylglycerol (DAG) and IP<sub>3</sub>, which can activate protein kinase C and release free calcium from intracellular stores, respectively (Berridge and Irvine, 1984; Berridge, 1987; Putney, 1987; Nishizuka, 1988). However, in view of the lack of effect of LH/hCG on the hydrolysis of phosphatidylinositol phosphates, the PLC pathway for arachidonic acid release may not be important in Leydig cells. Therefore, most of the investigations into the liberation of arachidonic acid in rat Leydig cells have concentrated on the action of PLA<sub>2</sub>.

There is evidence that LH causes a rapid release of [<sup>14</sup>C]-arachidonic from Leydig cells preincubated with radio-labelled arachidonic acid. The presence/involvement of PLA<sub>2</sub> activity in Leydig cells was suggested by the ability of mellitin, a known activator of PLA<sub>2</sub>, to release radio-labelled arachidonic acid in a dose-dependent manner (Chaudry et al., 1989; Cooke et al., 1991). These findings are in agreement with other investigations which showed a positive modulatory of mellitin and exogenous PLA<sub>2</sub> on testosterone production in Leydig cells (Mukhopadhyay et al., 1985; Abayasekara et al., 1990). Using inhibitors of PLA<sub>2</sub> action, quinacrine and dexamethazone, it was found that both LH- and dibutyryl cyclic AMP- stimulated testosterone production were inhibited without affecting cyclic AMP production, and without inhibition of cholesterol side chain cleavage activity (Abayasekara et al., 1990). This demonstrated that PLA<sub>2</sub> activity was essential to both LH- and cyclic AMP- stimulated steroidogenesis, which confirmed the previous investigations using lipoxygenase inhibitors and suggested the site of action of the arachidonic metabolites to be distal to cyclic AMP production and before the side

chain cleavage of cholesterol (Dix et al., 1984).

The inhibition of PLA<sub>2</sub> activity using dexamethazone has also been demonstrated in vivo (Cooke et al., 1991). The effect of dexamethazone on the activity of PLA<sub>2</sub> was inferred by measuring prostaglandin F<sub>2α</sub> (PGF<sub>2α</sub>) production in isolated Leydig cells from animals treated with hCG alone or hCG plus dexamethazone. It was found that in vivo treatment with dexamethazone caused a decrease in hCG-stimulated PGF<sub>2α</sub> production. The in vivo exposure to dexamethazone alone also decreased testosterone production in response to LH in vitro. These results are consistent with the inhibition of PLA<sub>2</sub> activity by the in vivo treatment with dexamethazone, and supports the idea that LH stimulates arachidonic acid release via the activation of PLA<sub>2</sub>.

The ability of dexamethazone to inhibit arachidonic acid release is thought to be through the induction of lipocortin synthesis (Hirata, 1984; Flower, 1984; DiRosa et al., 1984). Lipocortins are a family of phospholipase inhibitory proteins, that can suppress PLA<sub>2</sub> activity. Although the synthesis of lipocortins can be induced by glucocorticoids, such as dexamethazone, relatively high contents of lipocortins can be detected in non-treated cells (Hirata, 1984; Flower et al., 1984). It has been shown that dexamethazone can increase the inhibitory action of lipocortins through the formation of complexes between glucocorticoids and lipocortins (Hirata et al., 1987), this may explain the acute effects of dexamethazone treatment. Recently, in collaboration with R. J. Flower, it was demonstrated that Leydig cells show constitutive production of lipocortins (Phipp et al., unpublished observation), this suggested that PLA<sub>2</sub> may be inhibited under basal conditions.

Lipocortins can be phosphorylated by various kinases including PKA, PKC and tyrosine protein kinase (Hirata, 1981; Hirata et al., 1984; Varticovski et al., 1988;

Schlaepfer and Haigler, 1988), and the phosphorylated lipocortins have been shown to lose their capacity to inhibit PLA<sub>2</sub> in vitro. This may be a physiological mechanism for the activation of PLA<sub>2</sub> by hormone-induced kinase activity in vivo. In mouse Leydig (MA10) tumour cells, epidermal growth factor (EGF) was able to stimulate arachidonic acid release (Majercik and Puett, 1991), and these workers suggested that this may be through the phosphorylation of lipocortin by the EGF-receptor tyrosine kinase. In accordance with this mechanism of phosphorylation-inactivation of lipocortin and the stimulation of PLA<sub>2</sub>, cyclic AMP-stimulated testosterone production in Leydig cells has been shown to depend on PLA<sub>2</sub> activity (Abayasekara et al., 1990), cyclic AMP may activate PLA<sub>2</sub> through the PKA-stimulated phosphorylation of lipocortin.

#### 1.4.4. The activation of protein kinase C

From the observed effects of phorbol esters on Leydig cell function protein kinase C has been implicated in LH-receptor regulation, cyclic AMP production and steroidogenesis (Lin, 1985; Moger, 1985; Mukhopadhyay and Schumacher, 1985; Papadopoulos et al., 1985; Nikula et al., 1987; Cooke et al., 1990; Wang et al., 1991). Most of these observations show inhibitory effects of phorbol esters on LH/hCG-stimulated testosterone and cyclic AMP production, with a small stimulation of basal testosterone production. However, the mechanisms involved in the physiological activation of PKC in Leydig cells is still unclear. Recently, work in this laboratory (Lopez-Ruiz et al., 1992) has demonstrated that arachidonic acid can activate PKC in homogenates of rat testis Leydig cells, in a dose-dependent manner (maximum with 50 $\mu$ M AA). This activation of PKC was equipotent with the effect of phorbol esters and

diacylglycerol. These observations are consistent with the recent finding that Leydig cells express the three PKC isotypes,  $\alpha$ ,  $\beta$  and  $\tau$  at similar levels (Pelosin et al., 1991), and only the  $\alpha$ -isotype has been reported to be activated by arachidonic acid (Naor et al., 1988; Shearman et al., 1989). It is interesting to note that in granulosa cells, arachidonic acid was not able to stimulate PKC activity, and in these cells the  $\beta$ -isotype of PKC was predominant with no detectable  $\alpha$  or  $\tau$  forms (Johnson and Tilly, 1990). It was also found that PKC activity in Leydig cells could be down-regulated by a 5 hour pretreatment with PMA (100nM) or arachidonic acid (25 $\mu$ M), this down-regulation could be correlated with the loss of inhibitory activity of these two compounds on LH-stimulated testosterone production. In the case of arachidonic acid there was even a potentiation of LH-stimulated testosterone production which paralleled the loss of PKC activity.

Taken together the above findings suggest that in rat Leydig cells, arachidonic acid liberated by the action of phospholipases could activate PKC activity, and may constitute an inhibitory pathway in the regulation of steroidogenesis. The level of free arachidonic acid resulting from hormone-stimulation, may control the degree of PKC activity and play a central role in the regulation of signal transduction in Leydig cells; low concentrations of arachidonic acid (via its metabolites) may be required for the stimulation of steroidogenesis, while higher concentrations may be inhibitory.

### **1.5. Intratesticular factors regulating Leydig cell function**

Under in vivo conditions the action of LH on Leydig cells in the testis is probably modified by intratesticular factors secreted by other testicular cells, including Leydig cells. Studies of factors which affect Leydig cell function in vivo is a progressive area

of research and has been covered in detail by recent reviews (Dufau, 1988; Sharpe, 1990; Rivier, 1990; Skinner, 1991). The present state of research suggests that the majority of local regulatory factors involved in cell-cell interactions are established hormones and neurotransmitters e.g. products of the POMC gene (Bardin et al., 1987; Fabbri, 1990).

### **1.6. Aims of this project**

The purpose of this research was to further the understanding of the acute regulation of steroidogenesis in purified testis Leydig cells. This project focused on the role of the calcium signalling pathway in the action of LH. During the course of this research some unexpected observations pertaining to the regulation of testosterone production were also pursued. These included the stimulatory action of calmidazolium, a calmodulin inhibitor, on steroidogenesis, and the potentiation of steroidogenesis through the removal of extracellular chloride ions. The roles of pH, protein kinase C and de novo synthesis of cholesterol were also investigated.

## **CHAPTER TWO**

### **Materials and Methods**

## 2.1 Materials

Mature male Sprague-Dawley rats (250 -300g) and mature BALBc mice were purchased from the Royal Free Hospital Comparative Biology Unit. Flat-bottomed mini 96 well culture plates, Ham's F12 nutrient mixture and Dulbecco's modified Eagle's minimum essential medium, without NaHCO<sub>3</sub> (DMEM) were purchased from Gibco, Paisley, Scotland, U.K. HEPES (tissue culture grade), DMSO, perchloric Acid, D-glucose, sodium chloride, potassium chloride, magnesium chloride, magnesium sulphate, manganese chloride, ammonium chloride, sodium bicarbonate, calcium acetate, activated charcoal and PEG were purchased from BDH. Dibutyryl cyclic AMP, 8-bromo-cyclic AMP, sodium gluconate, potassium gluconate, lanthanum chloride, DTPA, Triton X-100R, A23187, 4-bromo-A23187, angiotensin-II, TMB-8, nifedipine, nigericin, amiloride, DIDS, SITS, bovine serum albumin (BSA, fraction V), poly-L-lysine, Percoll, trypsin inhibitor (1% sterile filtered solution), mevalonate, aminoglutethimide, calmidazolium, trifluoperazine, 22(R)-hydroxycholesterol, pregnenolone, testosterone, cholera toxin, pertussis toxin, phorbol 12-myristate,13-acetate (PMA) and phorbol 12,13-didecanoate (PDD) were purchased from Sigma Chemical Co. Dorset, UK. EGTA (Pures grade) and compactin were obtained from Fluka Biochemicals. Forskolin and thapsigargin were obtained from Novabiochem/Calbiochem. Ovine LH (oLH-22 and oLH-26, 2.3 IU/mg) and purified hCG were gifts from NIAMDD, Bethesda, MD, USA. Type I Collagenase was purchased from Worthington Biochemicals, Freehold, New Jersey USA. 2',7'-bis-(2-carboxyethyl)-5-(and-6)carboxyfluorescein, acetoxymethyl ester (BCECF/AM), quin-2/AM and fura-2/AM were obtained from Molecular Probes, INC. Eugene, OR 97402 USA. [<sup>3</sup>H]-pregnenolone and [<sup>3</sup>H]-testosterone were obtained from



Amersham International plc. Cyanoketone, SU-10603 and pregnenolone antibody were gifts from Dr. F.F.G. Rommerts (Erasmus University, Rotterdam, Netherlands).

## **2.2 Methods**

### **2.2.1. Cell isolation**

All animals were anaesthetised with halothane and killed by cervical dislocation.

**Rat Leydig cells** - These were prepared according to an established protocol of collagenase dispersion, centrifugal elutriation (using a JE-6B Beckman elutriation system) and Percoll gradient (0-90% v/v) centrifugation (Platts et al., 1988) with the following modifications. The collagenase digestion was carried out in DMEM-0.1% BSA, pH 7.4, containing 0.5mg collagenase and 20 $\mu$ l trypsin inhibitor per ml; each pair of decapsulated testes were placed in 7ml of this solution in a 30ml universal container. The universal container was then subjected to longitudinal shaking in a heated water-bath. Previously, the testes were shaken at 80 strokes per minute for 20min at 37°C. This has now been changed to 65 strokes per minute, and the incubations are continued until no interstitial connective tissue is visible. The digestion time for testes from 250-350g rats varies between 40-50min. This modified procedure has increased the yield of Leydig cells from 1 million to over 4 million cells per rat, without affecting the purity or the responsiveness of the cells to LH. After collagenase dispersion the cells are filtered through nylon gauze with mesh size of 75 $\mu$ m to remove fragments of seminiferous tubules. The cells from five animals are combined and subjected to centrifugal elutriation (this separates cells mainly on the basis of size) followed by Percoll density gradient centrifugation which separate on the basis of density. Leydig cell purity was routinely >95% as established

by 3 $\beta$ -hydroxysteroid dehydrogenase cytochemistry (Cooke et al.1983). The cell viability was determined by a NADH exclusion diaphorase assay (Aldred and Cooke, 1983).

**Mouse Leydig cells** - These were prepared as described previously (Hunter et al., 1982). Briefly, the testes were decapsulated and dispersed by mechanical flushing, and the released cells were filtered through nylon gauze and then purified by Percoll gradient (0-90%) centrifugation.

**Rat adrenocortical cells** - These were isolated using an established method with some minor modification (Haning et al., 1970; Fattah et al., 1977; Kramer, 1988). Rat adrenal glands were added to ice-cold Ham's F12, 15mM Hepes - NaOH pH 7.4. Adhering fat was removed and the adrenals were then ruptured by placing between two clean ice-cold glass plates. The medullae were carefully removed and the remaining capsules and cortical cells were subjected to collagenase digestion with 1mg collagenase /ml Ham's F12, 2% BSA, 15mM Hepes - NaOH pH 7.4. (In the preparation of adrenal glomerulosa cells only the capsules are used). The resulting cell suspension was filtered through nylon gauze to remove undigested capsular material and the suspended cells were pelleted in a bench centrifuge. The contaminating red cells were removed by Percoll gradient centrifugation.

### 2.2.2. Incubation medium

For normal incubations of Leydig cells, DMEM containing 0.1% BSA, 10mM Hepes - NaOH pH 7.4, was used. In experiments involving the measurement of intracellular calcium, the addition of  $\text{La}^{3+}$  and exclusion of extracellular  $\text{Ca}^{2+}$ , a simple salts medium was used consisting of (in mM): 140 NaCl, 5 KCl, 1.8  $\text{CaCl}_2$ , 1  $\text{MgSO}_4$ , 10 glucose, 0.1% BSA, 10 Hepes-NaOH pH 7.4. For the removal of  $\text{Ca}^{2+}$ , the  $\text{CaCl}_2$  was replaced with 0.2mM EGTA to chelate any remaining  $\text{Ca}^{2+}$ . DMEM could not be used for experiments involving the addition of  $\text{La}^{3+}$  to the incubation medium, since  $\text{La}^{3+}$  forms insoluble precipitates with phosphates. The measurement of intracellular pH was carried out in Hank's buffered saline solution (HBSS), modified as described in chapter 5.

In experiments where the removal of extracellular chloride ions were required, the sodium and potassium chloride salts were replaced with equimolar gluconate salts. The control cells were incubated in (in mM): 140 NaCl, 5 KCl, 1.8 Ca-acetate, 1  $\text{MgSO}_4$ , 10 glucose, 0.1% BSA, 10 Hepes-NaOH pH 7.4.

Incubations of adrenocortical cells were performed in Ham's F12, 0.2% BSA, 15mM Hepes-NaOH pH 7.4. The measurements of intracellular calcium in adrenal glomerulosa cells were carried out in a simple salts medium (in mM): 140 NaCl, 3.8 KCl, 1.8  $\text{CaCl}_2$ , 1  $\text{MgSO}_4$ , 10 glucose, 0.2% BSA, 15mM Hepes-NaOH pH 7.4.

### 2.2.3. Incubations conditions

In routine incubations, cells were plated at a density of 20,000 cells/well in a final volume of 200 $\mu$ l. Incubations were in an air incubator, at 34°C for Leydig cells and 37°C for adrenocortical cells. Leydig cells were preincubated for 2 to 4 hours prior to the addition of agonists and antagonists. This preincubation period has been shown to improve their responsiveness (Cooke et al., 1977). In experiments where the measurement of pregnenolone production was required, the further metabolism of this steroid was blocked by the addition of cyanoketone (5 $\mu$ M) and SU10603 (20 $\mu$ M) (inhibitors of 3 $\beta$ -hydroxysteroid dehydrogenase and 17 $\alpha$ -hydroxylase respectively) to the incubation medium 30mins prior to stimulation of the cells.

In order to focus on the total production of cyclic AMP in cells, the break down of cyclic AMP to 5'AMP was inhibited by the addition of the phosphodiesterase inhibitor, isobutyl methylxanthine (IBMX), to the incubation medium.

The addition of aminoglutethimide, calmidazolium, trifluoperazine, compactin, TMB-8, nifedipine, DIDS, SITS, BCECF, quin-2, fura-2, thapsigargin, A23187, PMA and PDD to Leydig cells were by the complete change of the incubation medium to a medium containing the appropriate concentrations. Calmidazolium was added to adrenocortical cells in 100 $\mu$ l of medium containing twice the final concentration of calmidazolium to 100 $\mu$ l of medium and cells within each well. The final concentration of DMSO (solvent for the above compounds) was constant for all the wells within each experiment and did not exceed 0.5% (v/v). This concentration of DMSO has no adverse effects on cell viability or steroidogenesis. LH, hCG, cyclic AMP analogues and other water-soluble test agents were dissolved in incubation medium and added as a 10 $\mu$ l

concentrate to give the required final concentration. Incubations were stopped with 50 $\mu$ l of 3 M perchloric acid (HClO<sub>4</sub>) 2 hours after stimulation and stored at -20°C. Samples were thawed and neutralized with 60 $\mu$ l of 2.16 M tripotassium phosphate (K<sub>3</sub>PO<sub>4</sub>) prior to assay for testosterone, pregnenolone and cyclic AMP by radioimmunoassay.

#### **2.2.4. Measurement of testosterone, pregnenolone and cyclic AMP by radioimmunoassay.**

**Testosterone and Pregnenolone** - This was performed according to the method of Verjans et al., 1973 and van der Vusse et al., 1975, respectively. The limit of detection for testosterone and pregnenolone was 5pg and 50pg, respectively. The free (cold and hot) steroids were separated from the bound steroids by activated charcoal, and the radioactivity of the bound steroids were determined by liquid scintillation in a Beckman LS5000 scintillation counter. The determinations are expressed as ng steroid / 10<sup>6</sup> cells.

**Cyclic AMP** - This was performed according to the method of Steiner et al., 1972, with the modifications of Harper and Brooker, 1975. The limit of detection was 25 femtomoles (10<sup>-15</sup> moles). The cyclic AMP (cold and hot) bound to the antibody were precipitated with 16% PEG. The radioactivity of the precipitates were determined in a gamma-counter. The determinations are expressed as pmoles cyclic AMP / 10<sup>6</sup> cells.

Statistical significance was determined by the unpaired Student's t-test. Results were considered statistically different at a probability (P) of less than 0.05.

### 2.2.5. Measurement of intracellular calcium using quin-2 and fura-2

The fluorescent calcium chelators quin-2 and fura-2 (Tsien et al., 1982; Grynkiewicz et al., 1985) change their fluorescence intensity on binding calcium (fig. 2.1). These water soluble chelators can be introduced into cells, via their lipid soluble acetoxymethyl esters derivatives. These esters pass freely into cells, and the free acid forms are released inside the cell through the action of intracellular esterases. By the use of a fluorescence spectrophotometer, changes in intracellular calcium can be monitored as changes in the emission intensity (fig. 2.1).

Experiments with quin-2 were carried out according to Sullivan and Cooke, 1986. Cells were loaded with quin-2 by incubation in medium containing 20 $\mu$ M quin-2/AM ester, and loading was monitored by observing a shift in the emission spectra from 430nm (unhydrolysed quin-2/AM ester) to 492nm (quin-2 free acid), at an excitation wavelength of 339nm. The loaded cells were centrifuged, washed twice and resuspended to give a final cell concentration of 10<sup>6</sup> cells / ml; 1ml of the cell suspension was used for each fluorometric measurement. The cells have to be constantly stirred to prevent sedimentation, and also to maintain a stable base-line.

The measurement of intracellular calcium in Leydig cells using stirred suspensions was found to be unreliable because of excessive cell damage. Together with Dr. Sullivan, who had carried out the original calcium measurements in quin-2 loaded Leydig cells, it was decided that a less destructive method was required. Therefore, a method was developed where cells were attached to glass coverslips coated with poly-L-lysine. Initially rat-tail collagen was prepared as a coating agent, but it was found to inhibit steroidogenesis in Leydig cells (Fig. 2.2), so it was not used further.

**Fig. 2.1 Structure and fluorescence characteristics of Quin 2 and Fura 2.**

(adapted from Tsien, 1980 ; Grynkiewicz et al., 1985)

Dye	$K_a$ (nM)	Absorbance $\lambda_{max}$ (nm)		Maximum absorption coefficient ( $M^{-1}\cdot cm^{-1}$ )	Emission $\lambda_{max}$ (nm)		Quantum efficiency
		Anion	Calcium ligand		Anion	Calcium ligand	
Quin2	114	339	365	6	492	0.14	0.03
Fura-2	224	362	335	33	512	0.23	0.49

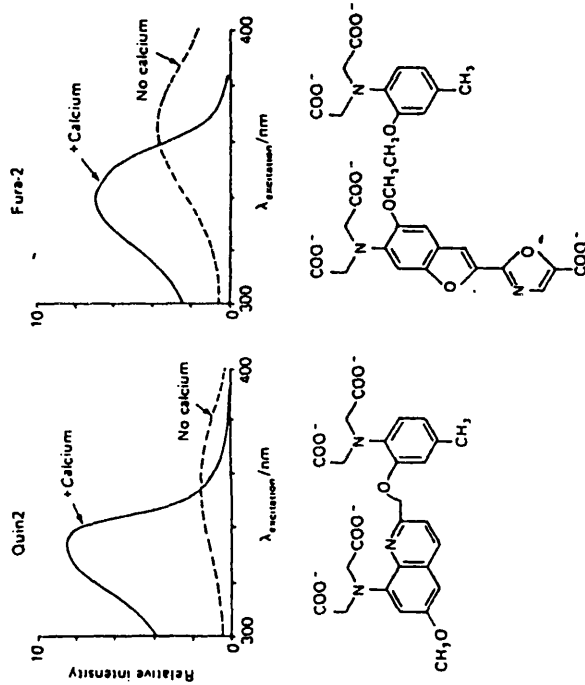
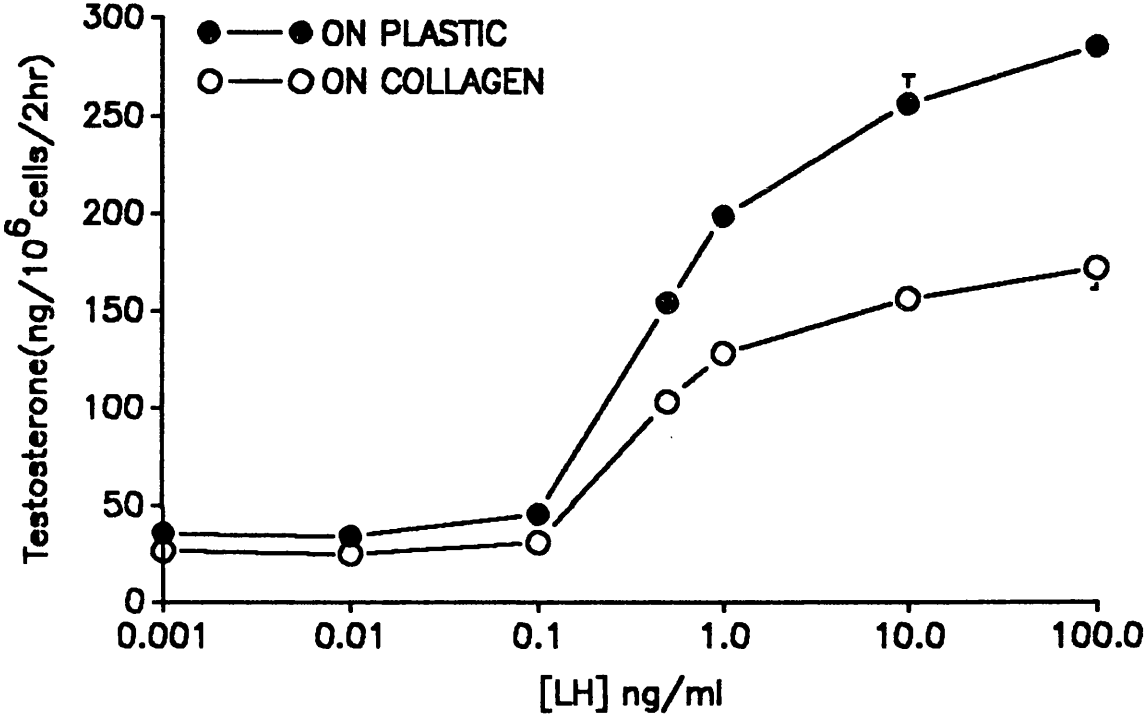


Figure 2.1



**Fig. 2.2 The effect of collagen on LH-stimulated testosterone production.** Leydig cells ( $5 \times 10^4$ / well/  $500\mu\text{l}$ ) were preincubated for 2 hours on collagen coated glass coverslips or directly on plastic culture wells. These cells were then stimulated for a further 2 hours with increasing concentrations of LH. The testosterone produced was measured in the incubation media as described in the Methods. Each point represents the mean  $\pm$  S.E. for triplicate incubations within one of two similar experiments.

Figure 2.2



Borosilicate glass coverslips (thickness No.1, cut to 13mm x 18mm) were washed with mild detergent and extensively rinsed with distilled water followed by 70% ethanol, in which they were subsequently stored until required. Prior to coating with poly-L-lysine, the coverslips were dried by passing them individually through a gas flame while holding them with a pair of forceps. The dry coverslips were then placed in the bottom of a large petri-dish and covered for 1 hour with a solution containing poly-L-lysine (10 $\mu$ g/ml). Coverslips were removed and allowed to air dry overnight in a sterile lamina-flow cabinet at room temperature. These dried coverslips were then transferred to a 12-well culture plate, one coverslip per well. The Leydig cells were plated onto the coverslips by carefully adding 150 $\mu$ l of cells (2 x 10<sup>6</sup> cells/ml) to each coverslip. The 12-well plate was not disturbed for 1 - 2 hours to allow the attachment of the cells. After this time 2 ml of fresh medium was carefully added to each well, and the cells were incubated for another hour before they were loaded with fluorescent ion chelators.

With the coverslip system, the maximum number of cells in the path of the excitation beam was limited. Quin-2, because of its low fluorescence signal, was found to be unsuitable for calcium measurements in cell monolayers. Therefore, fura-2 was used instead of quin-2. The fluorescence of fura-2 is approximately 30 times brighter than quin-2 (approximately 6 times the absorbance and 5 times the quantum yield) (Grynkiewicz et al., 1985).

However, there are problems with the use of fura-2 in some cells. These include problems with dye loading; ester hydrolysis; intracellular compartmentalization and the release of fura-2 to the medium during incubation (Molgaroli et al., 1987). The optimal conditions of loading cells with fura-2 have to be achieved by independently varying the concentration of fura-2/AM and the temperature of incubation. For Leydig cells there

were problems with dye loading and the release of calcium sensitive dye into the medium. The release of dye into the medium was temperature-dependent and gave an increasing base-line (see chapter 3). However, Leydig cells could be adequately loaded with dye by incubating cells at room temperature with 1ml medium containing  $5\mu\text{M}$  fura-2/AM for 30 - 40 mins, followed by 30 mins in fresh medium at  $34^\circ\text{C}$ . This procedure allows cells to be loaded with fura-2/AM at room temperature, and the release of the fura-2 free acid by action of intracellular esterases at  $34^\circ\text{C}$ . The leakage of fura-2 from the cells into the medium was removed by continuous superfusion of fresh medium ( $34^\circ\text{C}$ ) through the cuvette.

Figure 2.3 illustrates the setup used to monitor fluorescence changes in cells attached to coverslips. The coverslip was secured in a fixed position by the use of two split teflon rings. The bottom ring (3mm high) was necessary to hold the coverslip above the small magnetic stirring bar, and the top ring (8mm) was used to secure the coverslip. Fluorescence from fura-2 loaded cells was recorded by measuring the emission at 500nm with excitation wavelength at 340nm. Measurements were carried out in a Perkin-Elmer MPF-44B fluorescence spectrophotometer fitted with a heated cuvette holder and magnetic stirrer. The medium in the cuvette was continuously changed using a peristaltic-pump (Gilson Minipulse 2).

The measurement of intracellular calcium in adrenal glomerulosa cells was carried out in cell suspensions (Hausdorff and Catt, 1988). The adrenal cells were loaded with fura-2 by incubating the cells in a low potassium (3.8mM) medium containing  $2\mu\text{M}$  fura-2/AM for 60min. The cells were washed twice with fresh medium, by centrifugation and resuspension. The cells were then stored up to two hours on ice at a concentration of  $2 \times 10^6$  cell/ml in low potassium medium until required. The

**Fig. 2.3** A system for measuring intracellular fluorescence using a cuvette and cells attached to a glass coverslip. The coverslips are coated with poly-L-lysine to aid the attachment of cells. The split teflon rings are used to secure the coverslip in a diagonal position and also to raise the coverslip above the magnetic stirring bar.

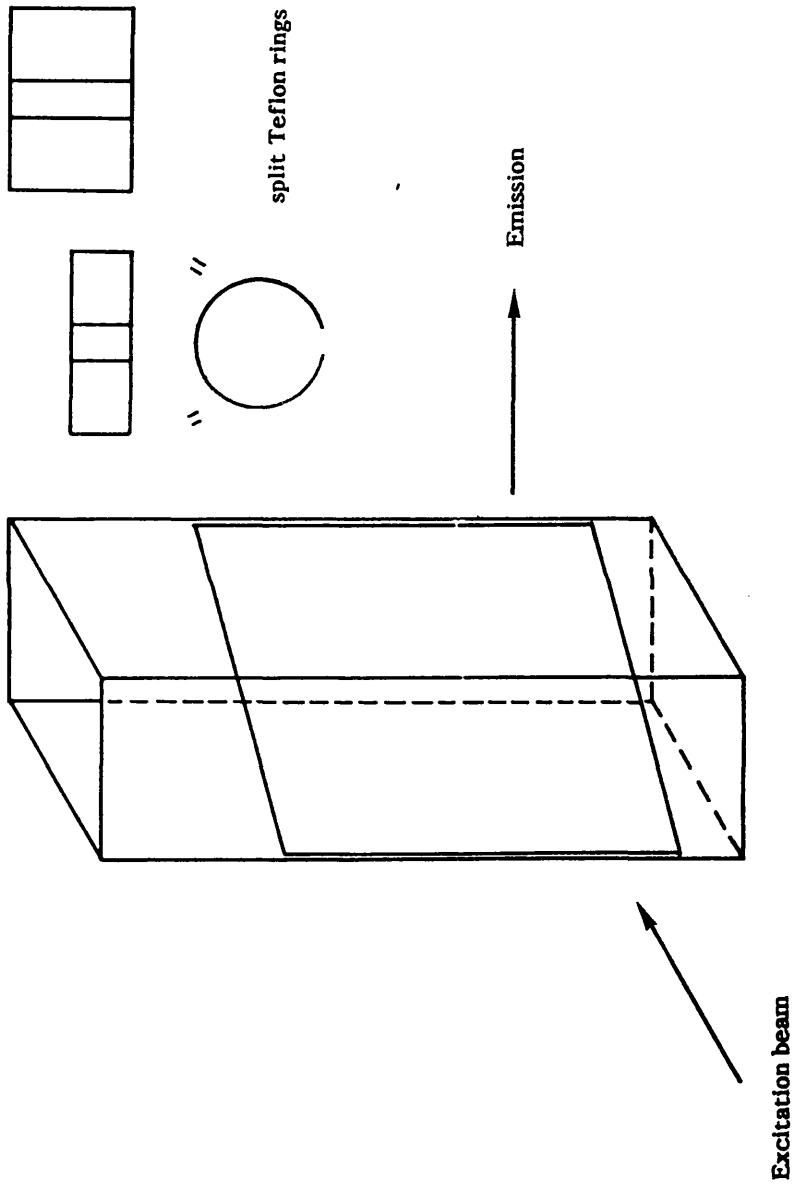


Figure 2.3

cells (1ml) were allowed to warm up in the 1ml round cuvette for 10min before the fura-2 fluorescence was measured.

#### **2.2.6. Measurement of intracellular pH changes using BCECF**

The measurement of intracellular pH was carried out using the coverslip/superfusion system described in the last section. The basic change was the use of a different fluorescent probe, BCECF instead of fura-2. The Leydig cells were loaded with the indicator by incubating cells with  $3\mu\text{M}$  BCECF/AM in HBSS for 40mins. These coverslips were then washed with fresh medium before use.

## **CHAPTER THREE**

### **Role of Intracellular Calcium in Testosterone Production**



### **3.1. INTRODUCTION**

It is generally accepted that steroidogenesis in Leydig cells is regulated by Luteinizing hormone (LH) via the second messenger cyclic AMP. Cyclic AMP analogues and agents such as forskolin and cholera toxin which increase cyclic AMP levels, will also stimulate steroidogenesis. However, it has been known for a long time that LH will stimulate near-maximal steroidogenesis before cyclic AMP production is detectable (Catt and Dufau, 1973; Moyle and Ramachandran, 1973; Rommerts et al., 1973). Because of this discrepancy in the amount of LH needed for an increase in cyclic AMP levels and stimulation of testosterone production, the obligatory requirement of cyclic AMP in the action of LH has been questioned. It has been suggested that at low concentrations of LH other substances may act as second messengers; one of these is calcium.

It has been shown that for full steroidogenesis in rat Leydig cells, calcium must be present in the incubation medium (Janszen et al., 1976); subsequent addition of calcium to the incubation medium restores the testosterone response to LH, indicating that the effect of removing extracellular calcium is not due to irreversible damage of the Leydig cells. Also, the activation of cyclic AMP dependent protein kinase by LH is not decreased by the omission of calcium from the incubation medium, suggesting that calcium may be involved at a stage beyond cyclic AMP production. More recently, a LH-stimulated increase in the intracellular calcium concentration  $[Ca^{2+}]_i$ , has been demonstrated in rat Leydig cells and bovine luteal cells loaded with the fluorescent calcium indicator, Quin-2 (Sullivan and Cooke, 1986; Davis et al., 1987).

In this chapter the results of further investigations into the involvement of calcium in the regulation of testosterone production are presented. These include the effect of

calcium antagonists (lanthanum, nifedipine and TMB-8) and calcium agonists (A23187 and thapsigargin) on testosterone production, and the use of the fluorescent calcium indicator, Fura 2, to follow  $[Ca^{2+}]_i$  changes in rat Leydig cells (see chapter 2 for methods).

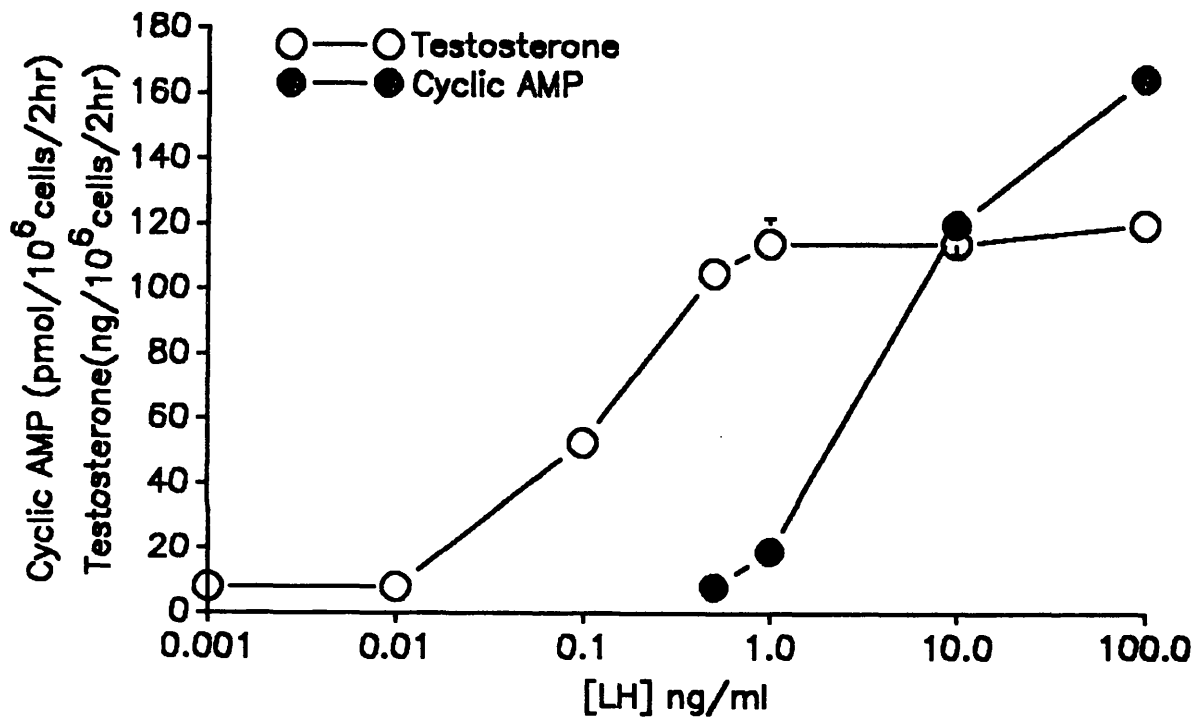
## 3.2 RESULTS

### 3.2.1. Calcium and testosterone production

Fig.3.1 shows the dissociation between testosterone and cyclic AMP production; from 0.01 to 0.1 ng/ml LH, testosterone production increased to half-maximal levels without there being any detectable change in cyclic AMP levels. From 0.5 to 1ng/ml LH, there was an approximate doubling of the cyclic AMP production with no further change in testosterone synthesis. The large increase in levels of cyclic AMP with 10 and 100ng/ml LH did not increase further testosterone production. The omission of calcium from the incubation medium caused an approximate 50% decrease in the testosterone production, stimulated by 0.5 to 100ng/ml LH (fig.3.2). Similarly, testosterone production stimulated by a cell-permeant analogue of cyclic AMP, 8-bromo-cyclic AMP, was inhibited to the same extent as LH (100ng/ml)-stimulated testosterone production, when calcium was omitted from the incubation medium (fig.3.3). The conversion of 22(R)OH-cholesterol (0.5, 1.0 and 10 $\mu$ M) to testosterone was unaffected by the removal of extracellular calcium (fig.3.4). Fig.3.5 shows the dose-dependent inhibition of LH-

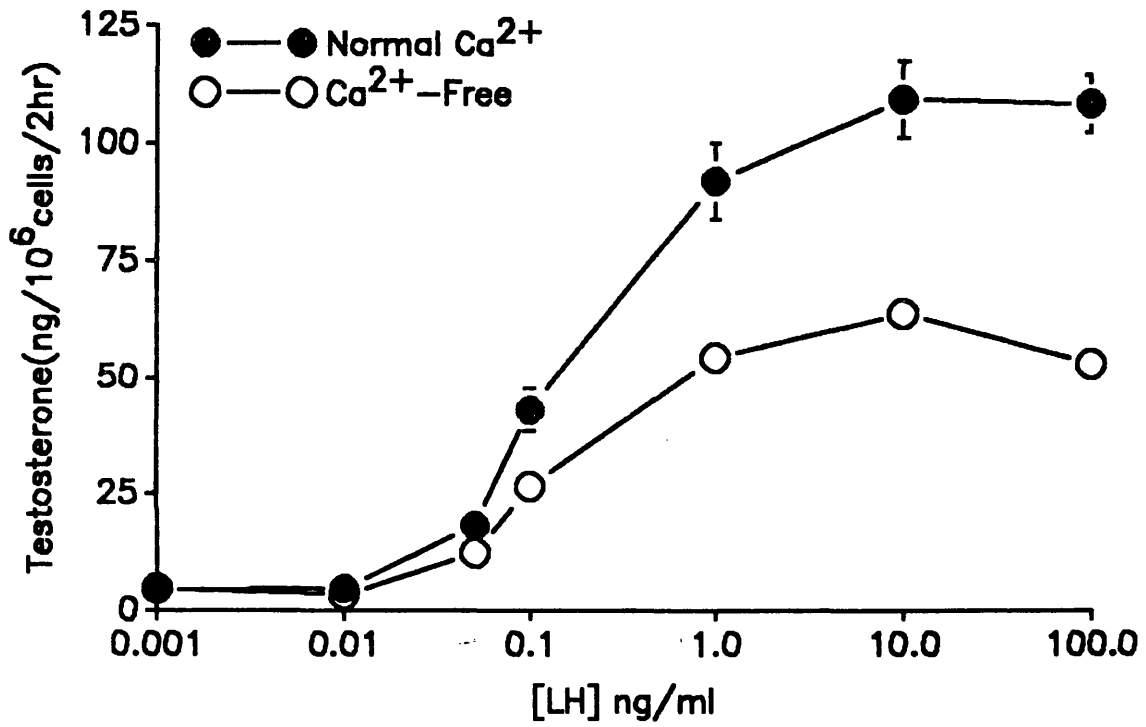
**Fig. 3.1 Dissociation between cyclic AMP and testosterone production in responds to stimulation with LH.** Leydig cells ( $2 \times 10^4$  cells/ well/  $200\mu\text{l}$ ) were incubated for 2 hours in the presence of increasing concentrations of LH. The cyclic AMP and testosterone produced was measured as described in the Methods. Each point represents the mean  $\pm$  S.E. for triplicate incubations within one of three similar experiments.

Figure 3.1



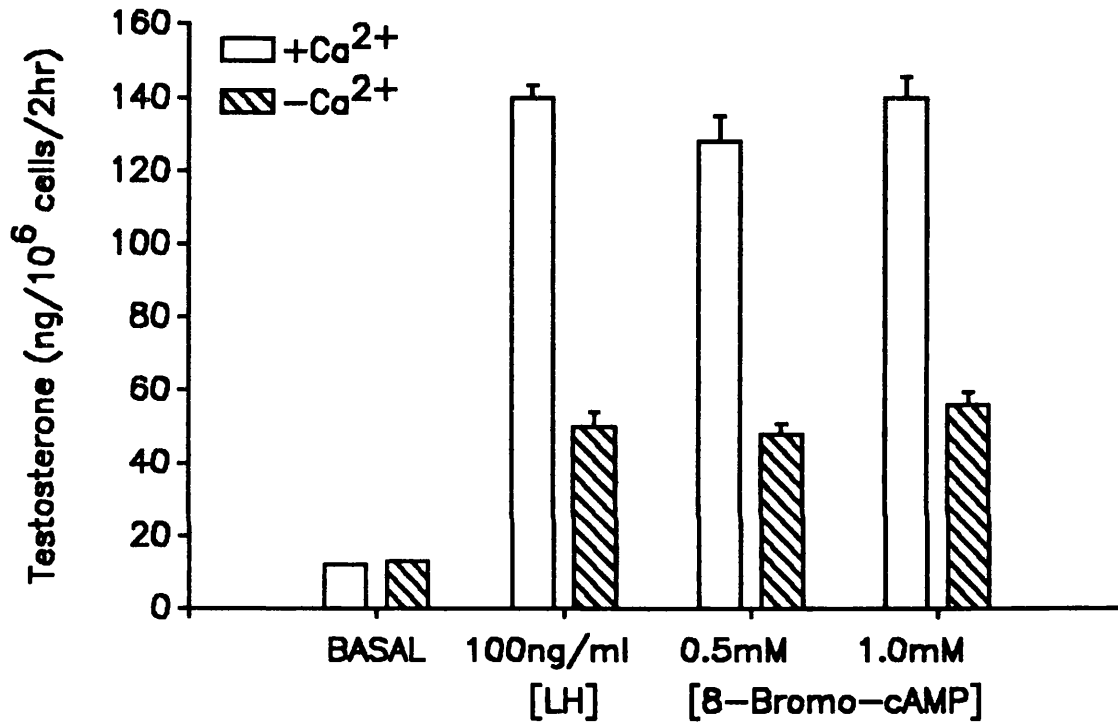
**Fig. 3.2 Effect of removing extracellular  $\text{Ca}^{2+}$  on testosterone production stimulated with LH.** Leydig cells ( $2 \times 10^4$  cells/ well/  $200\mu\text{l}$ ) were incubated for 2 hours in the presence and absence (no added  $\text{Ca}^{2+}$  plus 0.5mM EGTA) of extracellular  $\text{Ca}^{2+}$ , and stimulated with increasing concentrations of LH. The testosterone produced was measured in the incubation media as described in the Methods. Each point is the mean  $\pm$  S.E. for triplicate incubations within one of five similar experiments.

Figure 3.2



**Fig. 3.3 Effect of removing extracellular  $\text{Ca}^{2+}$  on LH- and 8-bromo-cAMP-stimulated testosterone production.** Leydig cells ( $2 \times 10^4$ / well/  $200\mu\text{l}$ ) were incubated for 2 hours in the presence an absence (no added  $\text{Ca}^{2+}$  plus 0.5mM EGTA) of extracellular  $\text{Ca}^{2+}$ , and stimulated with LH (100ng/ml) and 8-bromo-cAMP (0.5 and 1.0mM). The testosterone produced was measured in the incubation media as described in the Methods. Each point represents the mean  $\pm$  S.E. for triplicate incubations within one of five similar experiments.

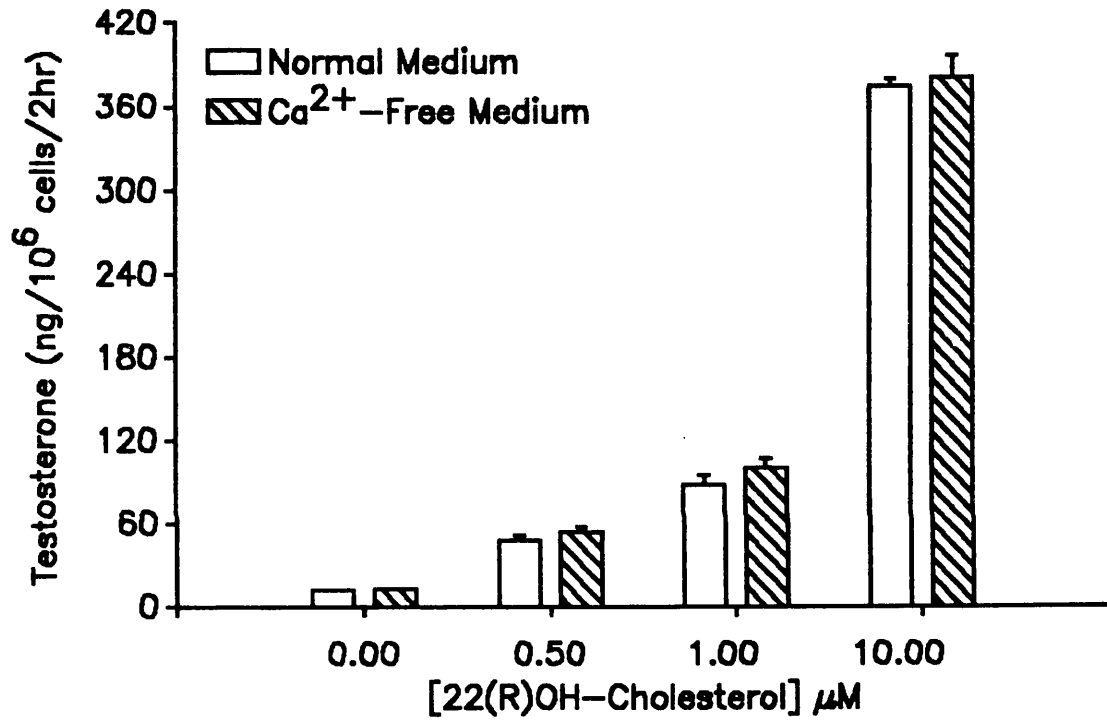
Figure 3.3





**Fig. 3.4** Effect of removing extracellular  $\text{Ca}^{2+}$  on the conversion of 22(R)OH-cholesterol to testosterone in Leydig cells. Leydig cells ( $2 \times 10^4$ / well/  $200\mu\text{l}$ ) were incubated for 2 hours with three different concentrations of 22(R)OH-cholesterol, and the testosterone produced was measured as described in the Methods. Each point represents the mean  $\pm$  S.E. for triplicate incubations within one of three similar experiments.

Figure 3.4

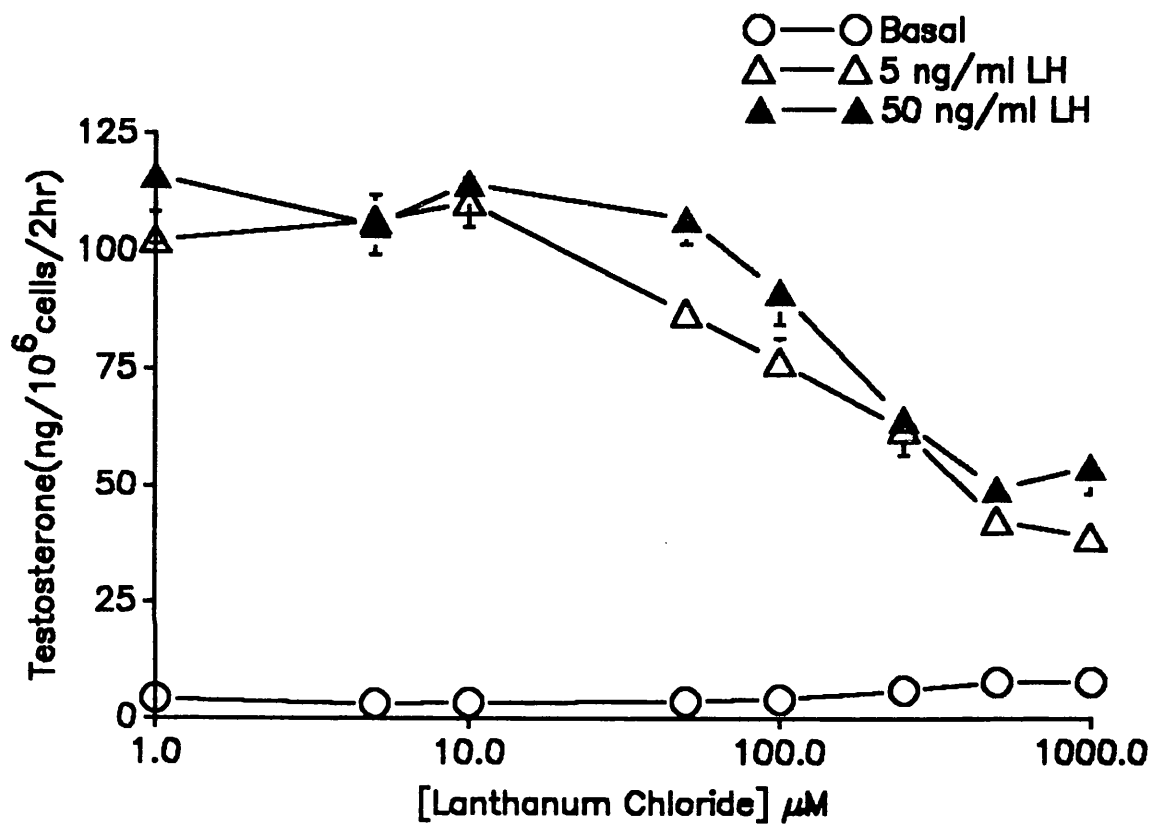


**Fig. 3.5 Effect of Lanthanum ions on LH-stimulated testosterone production.**

Leydig cells ( $2 \times 10^4$ / well/  $200\mu\text{l}$ ) were incubated for 2 hours in the presence of increasing concentrations of  $\text{La}^{3+}$ , and stimulated with and without LH (5 and 50ng/ml).

The testosterone produced was measured according to the Methods. Each point represents the mean  $\pm$  S.E. for triplicate incubations within one of two similar experiments.

Figure 3.5

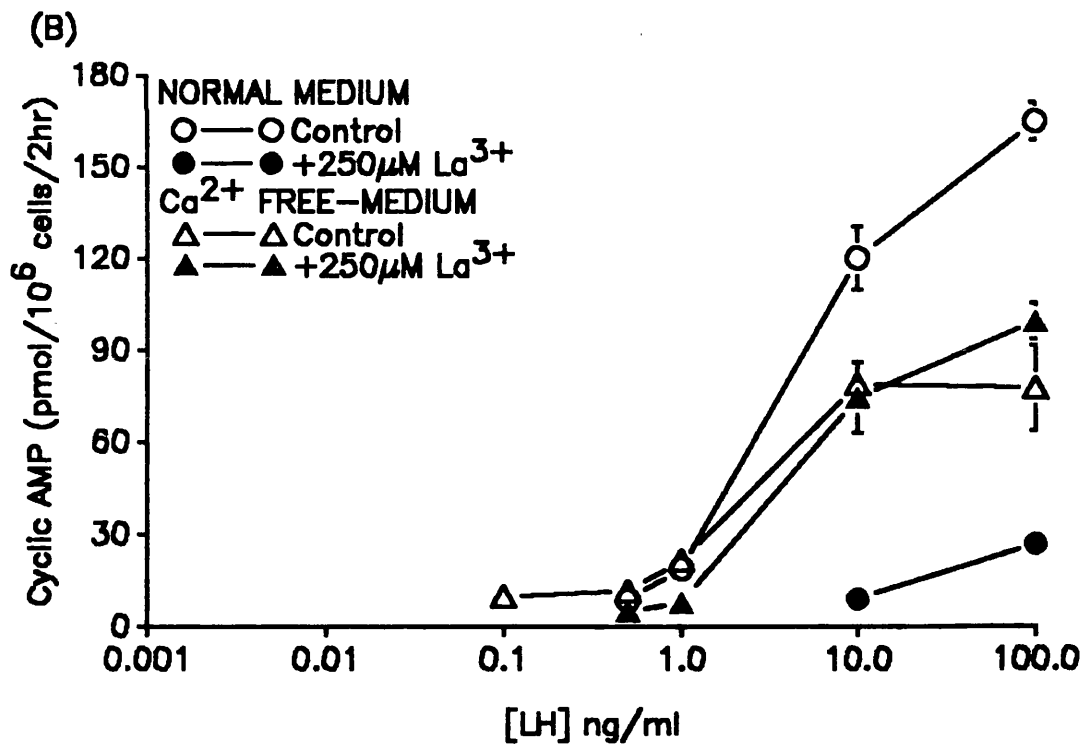
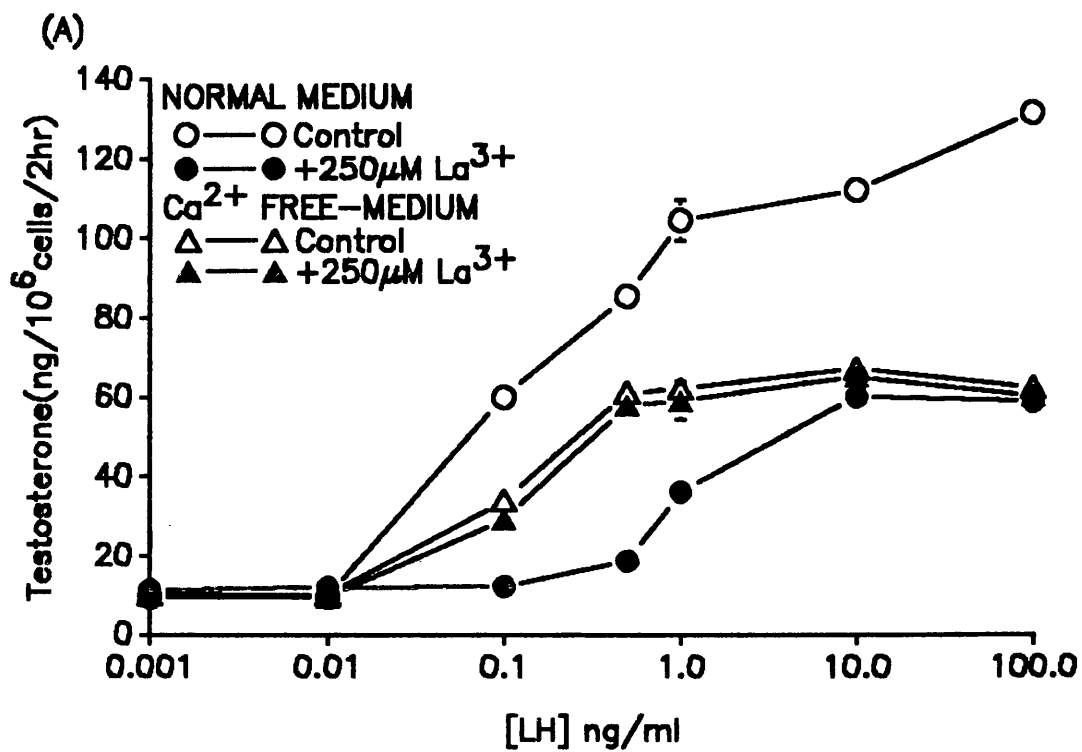


stimulated testosterone production by increasing concentrations of lanthanum in the incubation medium. Testosterone production stimulated by 5.0 and 50ng/ml LH were of similar magnitude. For these concentrations of LH, lanthanum inhibited testosterone production with an  $ID_{50}$  of approximately  $250\mu\text{M}$ . Testosterone production stimulated with 5.0 and 50ng/ml LH was inhibited by approximately 60% with  $1000\mu\text{M}$  lanthanum in the incubation medium. Further investigations were carried out using the  $ID_{50}$  concentration of  $250\mu\text{M}$  lanthanum. Fig.3.6 shows the effect of  $250\mu\text{M}$  lanthanum on testosterone and cyclic AMP production in response to increasing concentrations of LH (0.001 to 100ng/ml). In calcium containing medium  $250\mu\text{M}$  lanthanum caused an approximate 50% inhibition of testosterone production stimulated with 10 and 100ng/ml LH. However, under the same conditions testosterone production stimulated with 0.1, 0.5 and 1.0ng/ml LH was inhibited by 100%, 80% and 75% respectively. In these cells cyclic AMP production was only detectable with 10 and 100ng/ml LH; even at these concentrations of LH the cyclic AMP levels were decreased by 90% and 80% respectively. The exclusion of calcium from the incubation medium caused an approximately 50% decrease in both testosterone and cyclic AMP production. However, in calcium-free medium (0.5mM EGTA) the addition of lanthanum to the incubation had no affect on testosterone or cyclic AMP production in response to LH.

Fig.3.7 shows the effect of lanthanum on dibutyryl cyclic AMP-stimulated testosterone production. Lanthanum dose-dependently inhibited testosterone production stimulated by all concentrations of dibutyryl cyclic AMP (0.05, 0.1 and 1.0mM). With 1mM dibutyryl cyclic AMP,  $250\mu\text{M}$  lanthanum inhibited testosterone production by 40%, whereas with  $500\mu\text{M}$  and  $1000\mu\text{M}$  lanthanum there was a 50% inhibition of testosterone production. Testosterone production stimulated by 0.05 and 0.1mM dibutyryl cyclic

**Fig. 3.6 Effect of Lanthanum ions on LH-stimulated cyclic AMP and testosterone production.** Leydig cells ( $2 \times 10^4$ / well/  $200\mu\text{l}$ ) were incubated for 2 hours in the presence and absence of  $250\mu\text{M}$  ( $\text{ED}_{50}$ )  $\text{La}^{3+}$  with and without (no added  $\text{Ca}^{2+}$  plus  $0.5\text{mM}$  EGTA) extracellular  $\text{Ca}^{2+}$ . The cyclic AMP and testosterone produced were determined as described in the Methods. Each point represents the mean  $\pm$  S.E. for triplicate incubations within one of two similar experiments.

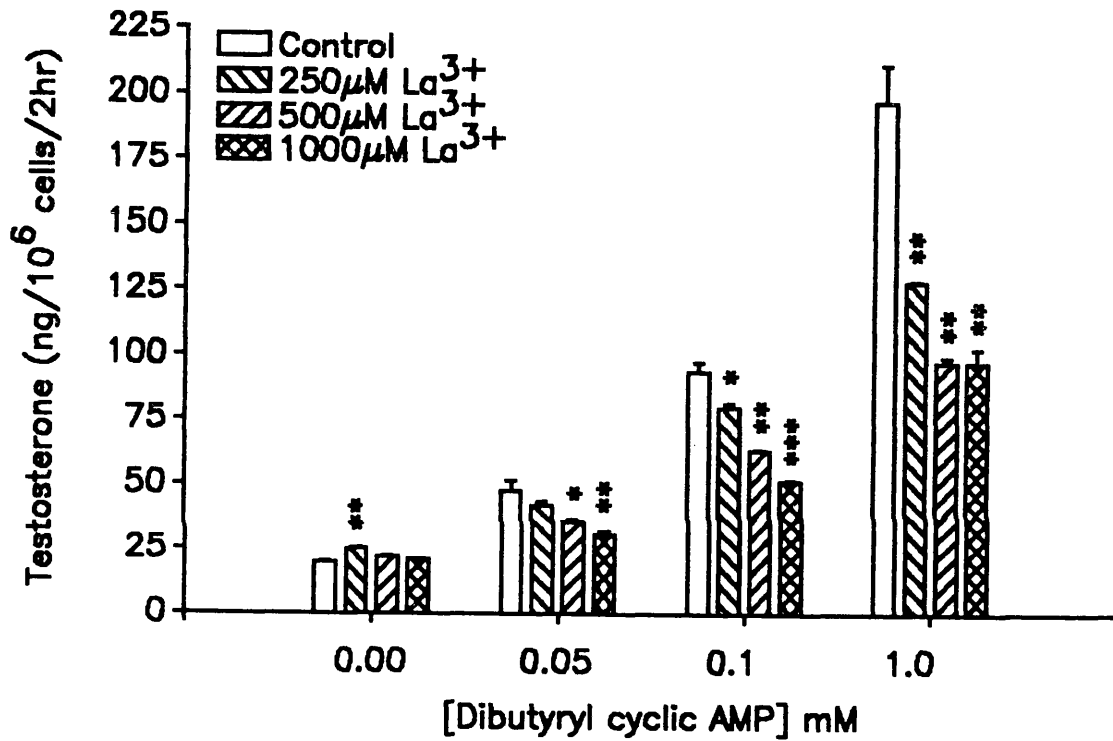
Figure 3.6



**Fig. 3.7 Effect of Lanthanum ions on dibutyryl cAMP-stimulated testosterone production.** Leydig cells ( $2 \times 10^4$  cells/ well/  $200\mu\text{l}$ ) were incubated in the absence and presence of different concentrations of lanthanum chloride, and stimulated with increasing concentrations of dibutyryl cAMP for 2 hours. The testosterone produced was determined as described in the Methods. Each point represents the mean  $\pm$  S.E. for triplicate incubations within one of two similar experiments. (\* P < 0.05; \*\* P < 0.01; \*\*\* P < 0.001, similar to control)



Figure 3.7



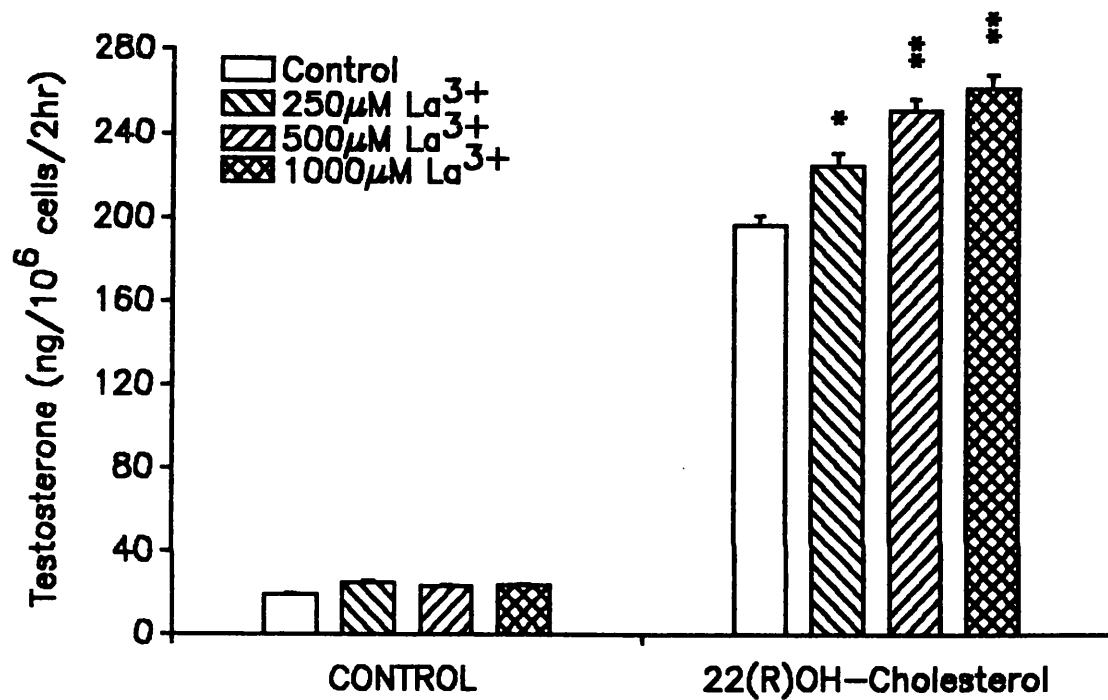
AMP was not inhibited by 250 $\mu$ M lanthanum, but 500 $\mu$ M lanthanum caused an inhibition of 25% and 35%, respectively, and with 1000 $\mu$ M lanthanum there was a 50% inhibition. Fig.3.8 shows the effect of lanthanum on the conversion of (5 $\mu$ M) 22(R)OH-cholesterol to testosterone. There was a dose-dependent stimulation of testosterone production, reaching 35% above control levels with 1000 $\mu$ M lanthanum. In all experiments with lanthanum, no inhibition of basal testosterone production was detected.

Nifedipine is a calcium antagonist known to block extracellular calcium entry through a specific type of calcium-channel, referred to as L-type voltage-dependent calcium-channel. Fig.3.9 shows a dose-response to nifedipine for LH-stimulated testosterone production. LH concentrations of 0.1, 1.0 and 10ng/ml gave similar levels of testosterone production in these cells. They also shared approximately the same ID<sub>50</sub> for inhibition by nifedipine. Using the ID<sub>50</sub> concentration of nifedipine, its effect on LH(0.001 to 100ng/ml)-stimulated testosterone production was further investigated. Fig.3.10 shows the effect of nifedipine on LH-stimulated testosterone production in the presence and absence of extracellular calcium. In calcium containing medium, the addition of 50 $\mu$ M nifedipine caused a 50% decrease in the LH-stimulated testosterone production. The removal of extracellular calcium gave the expected ~50% decrease in testosterone production. However, the addition of nifedipine to cells incubated in the absence of extracellular calcium caused a further 50% decrease of the LH-stimulated testosterone production.

A compound which has been reported to be an intracellular calcium antagonist, TMB-8, was investigated. Fig.3.11 shows the dose-dependent inhibition of LH-stimulated testosterone production by TMB-8. Both maximal and submaximal LH-stimulated testosterone production were inhibited with a similar ID<sub>50</sub> of approximately

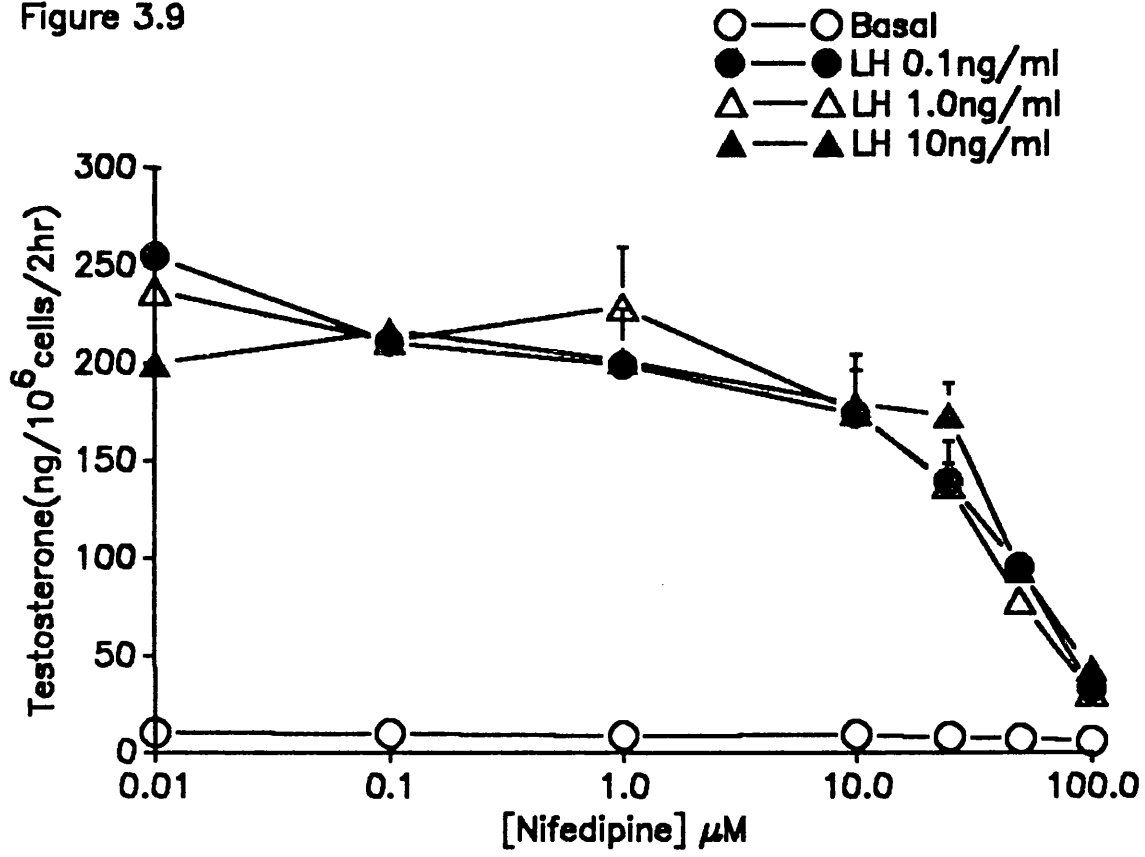
**Fig. 3.8 Effect of Lanthanum ions on the conversion of 22(R)OH-cholesterol to testosterone in Leydig cells.** Leydig cells ( $2 \times 10^4$  cells/ well/  $200\mu\text{l}$ ) were incubated with 22(R)OH-cholesterol ( $1\mu\text{M}$ ) for 2 hours in the absence and presence of increasing concentrations of lanthanum chloride. The testosterone produced was determined as described in the Methods. Each point represents the mean  $\pm$  S.E. for triplicate incubations within one of two similar experiments. (\*  $P < 0.05$ ; \*\*  $P < 0.01$ , similar to control)

Figure 3.8



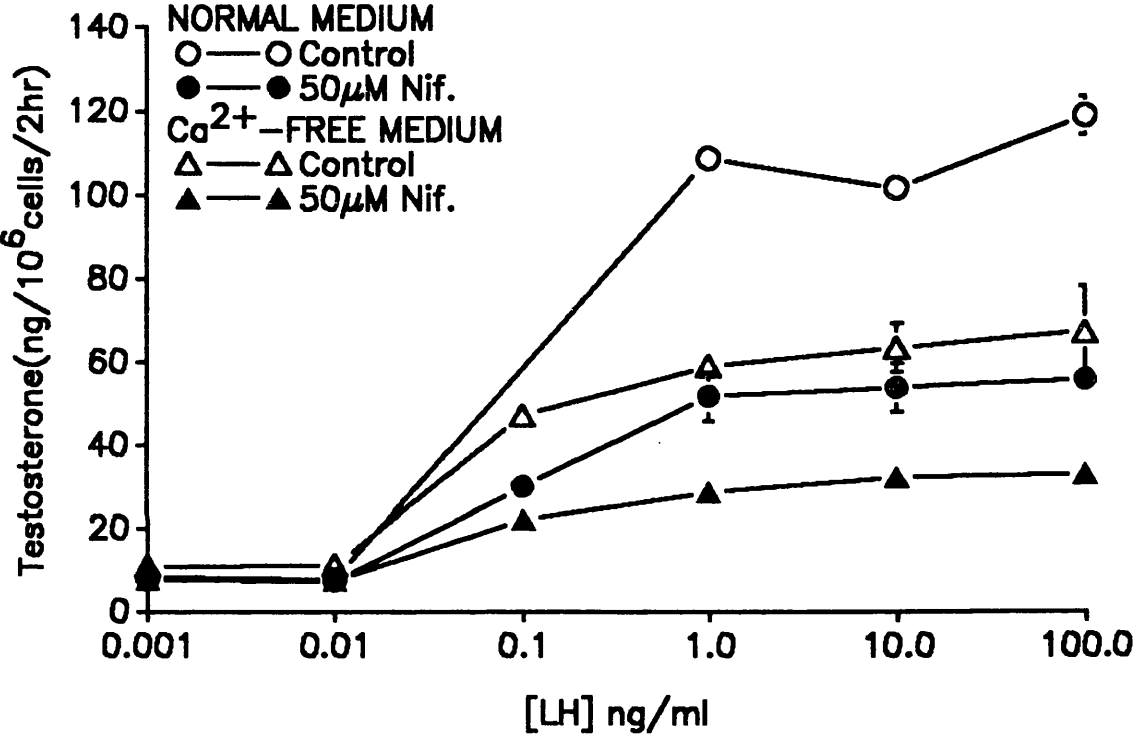
**Fig. 3.9 Effect of Nifedipine, an inhibitor of voltage-dependent calcium channels, on LH-stimulated testosterone production.** Leydig cells ( $2 \times 10^4$  cells/ well/  $200\mu\text{l}$ ) were incubated with increasing concentrations of Nifedipine, and stimulated with different concentrations of LH for 2 hours. The testosterone produced was measured as described in the Methods. Each point represents the mean  $\pm$  S.E. for triplicate incubations within one of three similar experiments.

Figure 3.9



**Fig. 3.10 Effect of Nifedipine on LH-stimulated testosterone production in the presence and absence of extracellular calcium.** Nifedipine ( $ED_{50}$  concentration of  $50\mu\text{M}$ ) was added to Leydig cells ( $2 \times 10^4$  cells/ well/  $200\mu\text{l}$ ) incubated in the presence and absence of extracellular  $\text{Ca}^{2+}$ , and stimulated with increasing concentrations of LH for 2 hours. The testosterone produced was measured as described in the Methods. Each point represents the mean  $\pm$  S.E. for triplicate incubations within one of two similar experiments.

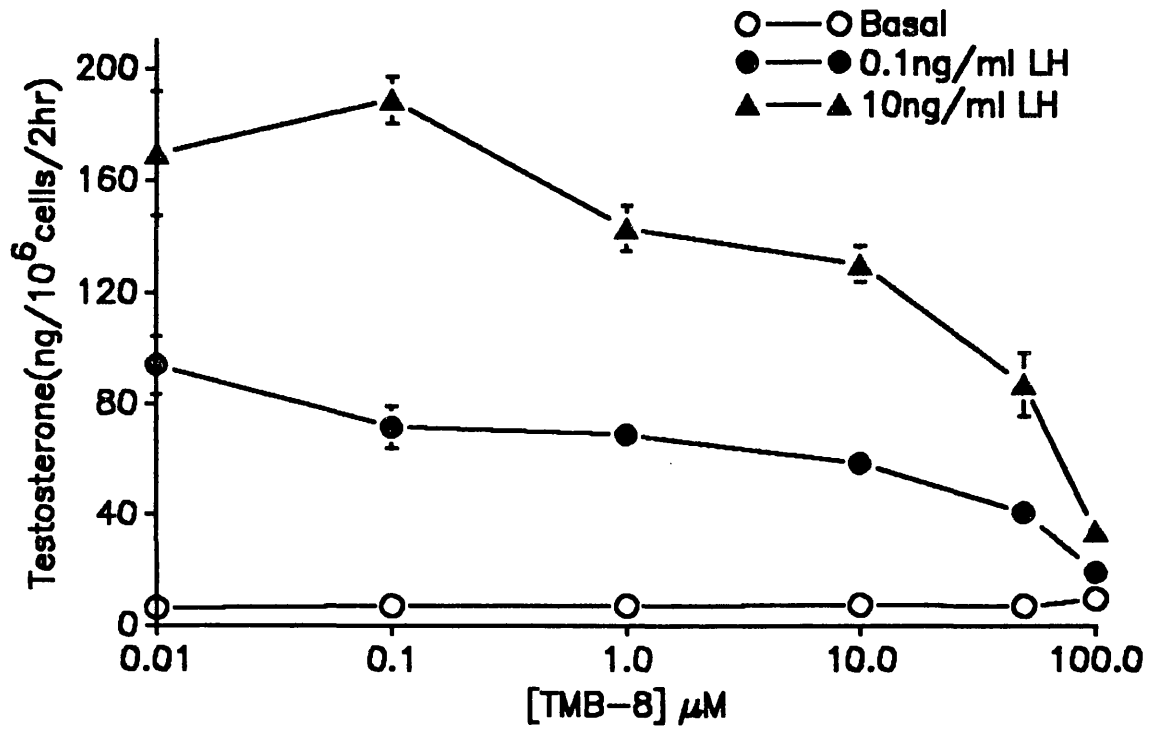
Figure 3.10





**Fig. 3.11 Effect of TMB-8, a putative inhibitor of calcium release from intracellular stores, on LH-stimulated testosterone production.** Leydig cells ( $2 \times 10^4$  cells/well/  $200\mu\text{l}$ ) were incubated with increasing concentrations of TMB-8 in the absence and presence of LH (0.1 and 10ng/ml) for 2 hours. The testosterone produced was determined as described in the Methods. Each point represents the Mean  $\pm$  S.E. for triplicate incubations within one of three similar experiments.

Figure 3.11



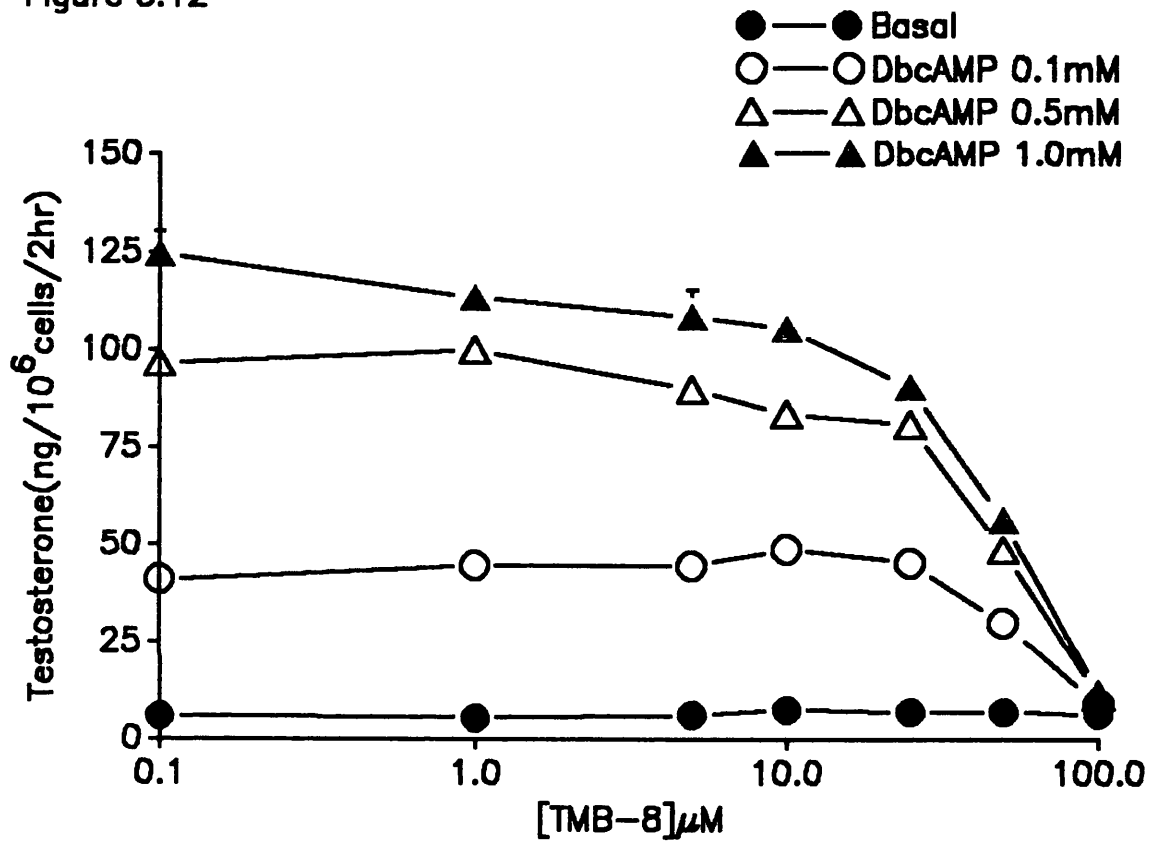
50 $\mu$ M TMB-8. Similarly, dibutyryl cyclic AMP-stimulated testosterone production was dose-dependently inhibited by TMB-8 (fig.3.12). Testosterone production stimulated with 0.1, 0.5 and 1.0mM dibutyryl cyclic AMP were all inhibited by TMB-8 with an ID<sub>50</sub> of approximately 50 $\mu$ M.

The effect of increasing intracellular calcium on LH- and dibutyryl cAMP-stimulated testosterone production was investigated using A23187 and thapsigargin. A23187 is a calcium ionophore, and will allow the entry of calcium ions through the plasma membrane. Thapsigargin increases intracellular calcium through the specific inhibition of the endoplasmic reticulum Ca<sup>2+</sup>/ATPase (Thastrup et al., 1990) without affecting the plasma membrane Ca<sup>2+</sup>/ATPase (Takemura et al., 1990). Cells treated with thapsigargin can maintain levels of intracellular calcium close to that produced by agonist stimulation (Jackson et al., 1988; Takemura et al., 1989).

Figure 3.13 shows the inhibition of LH- and dibutyryl cAMP-stimulated testosterone production with 1 $\mu$ M A23187. Similar results were found with thapsigargin (fig. 3.14). These results suggested the locus of inhibition to be post cyclic AMP production. Therefore, the effect of A23187 and thapsigargin on cholesterol side-chain cleavage activity was investigated using 22(R)-OH-cholesterol. The conversion of 22(R)-OH-cholesterol (0.5 $\mu$ M) to testosterone during a 2hr incubation was found to be unaffected by these compounds (**control** - 136.3  $\pm$  9.9 ng/10<sup>6</sup>cells; **thapsigargin** (400nM) - 128.0  $\pm$  14.6 ng/10<sup>6</sup>cells; **A23187** (1 $\mu$ M) - 135.2  $\pm$  9.4 ng/10<sup>6</sup>cells). The site of action of these compounds was therefore after cyclic AMP production and prior to the production of pregnenolone. These results demonstrate an inhibitory effect of elevated intracellular calcium on agonist-stimulated testosterone production.

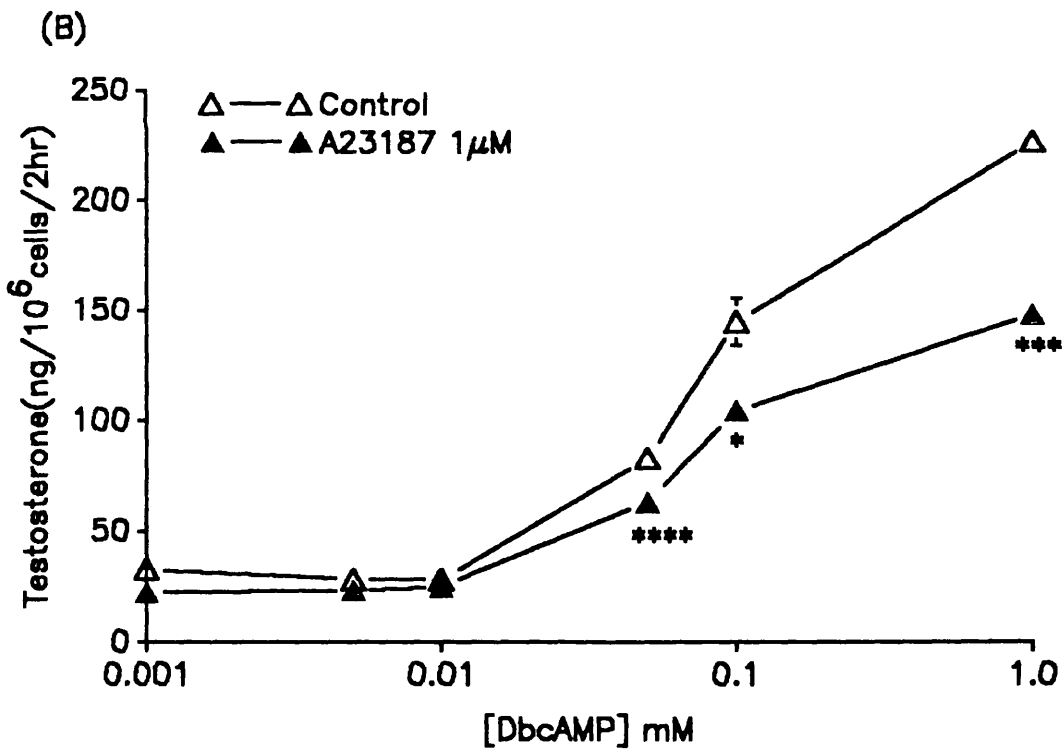
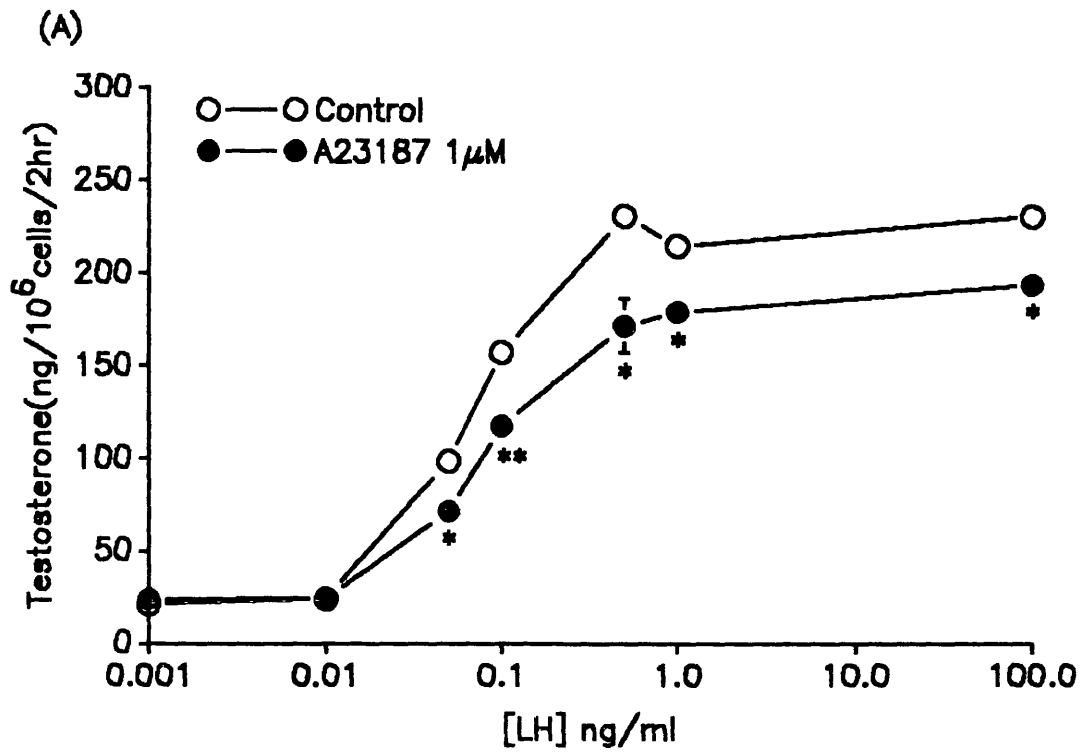
**Fig. 3.12** Effect of TMB-8, a putative inhibitor of calcium release from intracellular stores, on dibutyryl cAMP-stimulated testosterone production. Leydig cells ( $2 \times 10^4$  cells/ well/  $200\mu\text{l}$ ) were incubated with increasing concentrations of TMB-8, and stimulated with different concentrations of dibutyryl cAMP for 2 hours. The testosterone produced was determined as described in the Methods. Each point represents the mean  $\pm$  S.E. for triplicate incubations within one of two similar experiments.

Figure 3.12



**Fig. 3.13 Effect of A23187, a calcium ionophore, on LH- and dibutyryl cAMP-stimulated testosterone production.** Leydig cells ( $2 \times 10^4$  cells/ well/  $200\mu\text{l}$ ) were incubated for 2 hours with increasing concentrations of LH or dibutyryl cAMP in the absence and presence of A23187 ( $1\mu\text{M}$ ). The testosterone produced was determined as described in the Methods. Each point represents the mean  $\pm$  S.E. for triplicate incubations within one of two similar experiments. (\*  $P < 0.05$ ; \*\*  $P < 0.01$ ; \*\*\*  $P < 0.001$ ; \*\*\*\*  $P < 0.0001$ , similar to control)

Figure 3.13

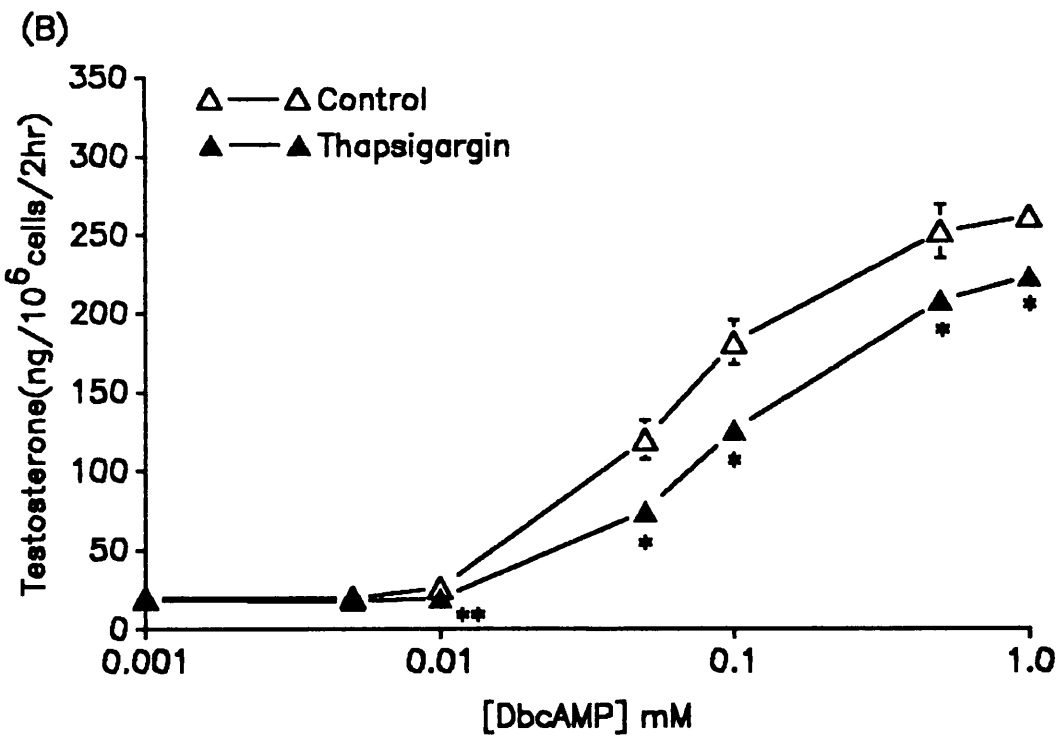
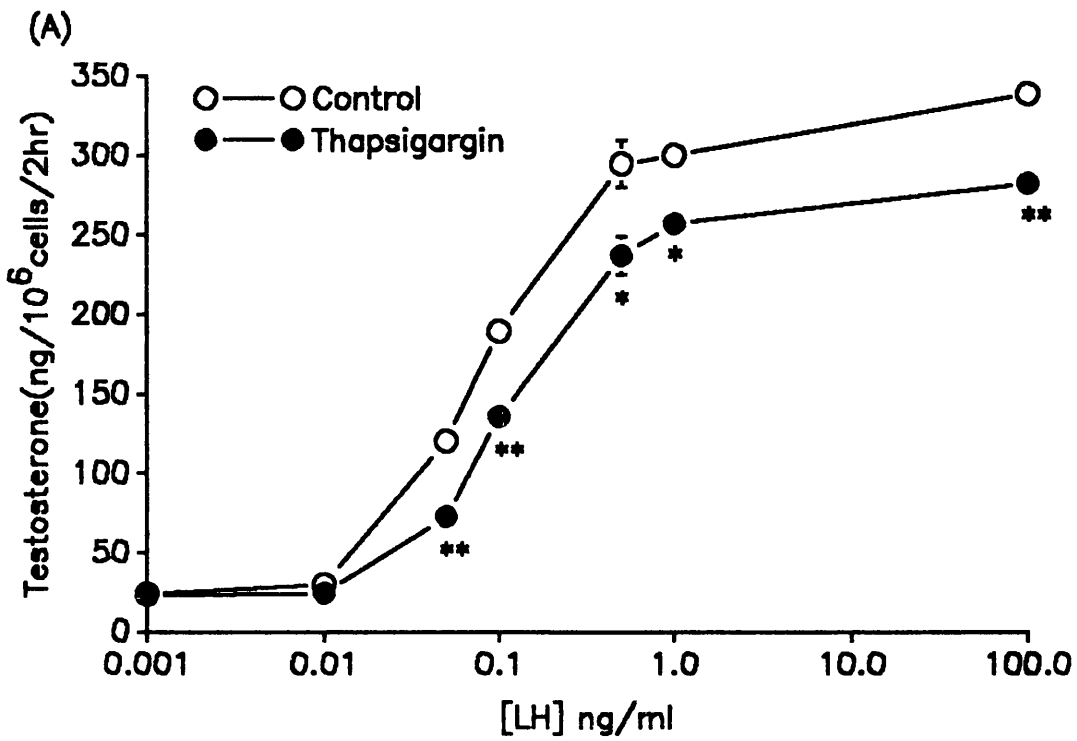


**Fig. 3.14 Effect of Thapsigargin, a specific inhibitor of the endoplasmic reticulum  $\text{Ca}^{2+}$ /ATPase, on LH- and dibutyryl cAMP-stimulated testosterone production.**

Leydig cells ( $2 \times 10^4$  cells/ well/  $200\mu\text{l}$ ) were stimulated with increasing concentrations of LH or dibutyryl cAMP for 2 hours in the absence and presence of 400nM Thapsigargin. The testosterone produced was determined as described in the Methods. Each point represents the mean  $\pm$  S.E. for triplicate incubations within one of two similar experiments. (\*  $P < 0.05$ ; \*\*  $P < 0.01$ , similar to control)



Figure 3.14



### 3.2.2. Modulation of intracellular calcium concentrations

Initial experiments were directed at repeating the previous published work using quin 2 loaded cells in stirred suspensions (Sullivan and Cooke, 1986). It was anticipated that this work would then be extended to investigate the mechanisms controlling calcium movements in Leydig cells and the role played by calcium in LH-stimulated testosterone production. However, no fluorescence increase in response to LH or ionomycin could be obtained. The ionomycin was tested on quin 2 loaded human platelets and found to be perfectly functional, in that it increased quin 2 fluorescence by acting as a calcium ionophore. Throughout these experiments, extensive clumping of the cells was clearly visible, these cell clumps could be dispersed with DNAase, which is indicative of cell damage. The impact of the quin 2 loading procedure on cell viability was investigated. A large loss of cell viability was evident; before loading the viability was  $93.6 \pm 2.5 \%$  (n=3), after loading and stirred in cuvette for 5min the viability fell to  $3.7 \pm 0.4 \%$  (n=3). Although stirred cell suspensions have been used routinely for monitoring quin 2 fluorescence changes in other cells, it was not a method of choice for Leydig cells.

The above fluorescence measurements were carried out under the supervision of Dr.Sullivan, who previously showed using the same methodology, that Leydig cells loaded with quin 2 responded to LH-stimulation by an increase in fluorescence. The reason for the present lack of responsiveness to LH is not known, but could be due to cell damage as suggested by the loss of cell viability. However, this did not appear to be a problem in previous experiments.

In order to avoid cell damage, a method was developed where cells were attached to glass coverslips coated with poly-lysine, and placed diagonally in a 1cm square cuvette

for fluorescence measurements (see chapter 2 for more details). In addition to its stability this method decreased the number of cells per measurement from 1 million cells to 300,000 cells, which is a considerable saving.

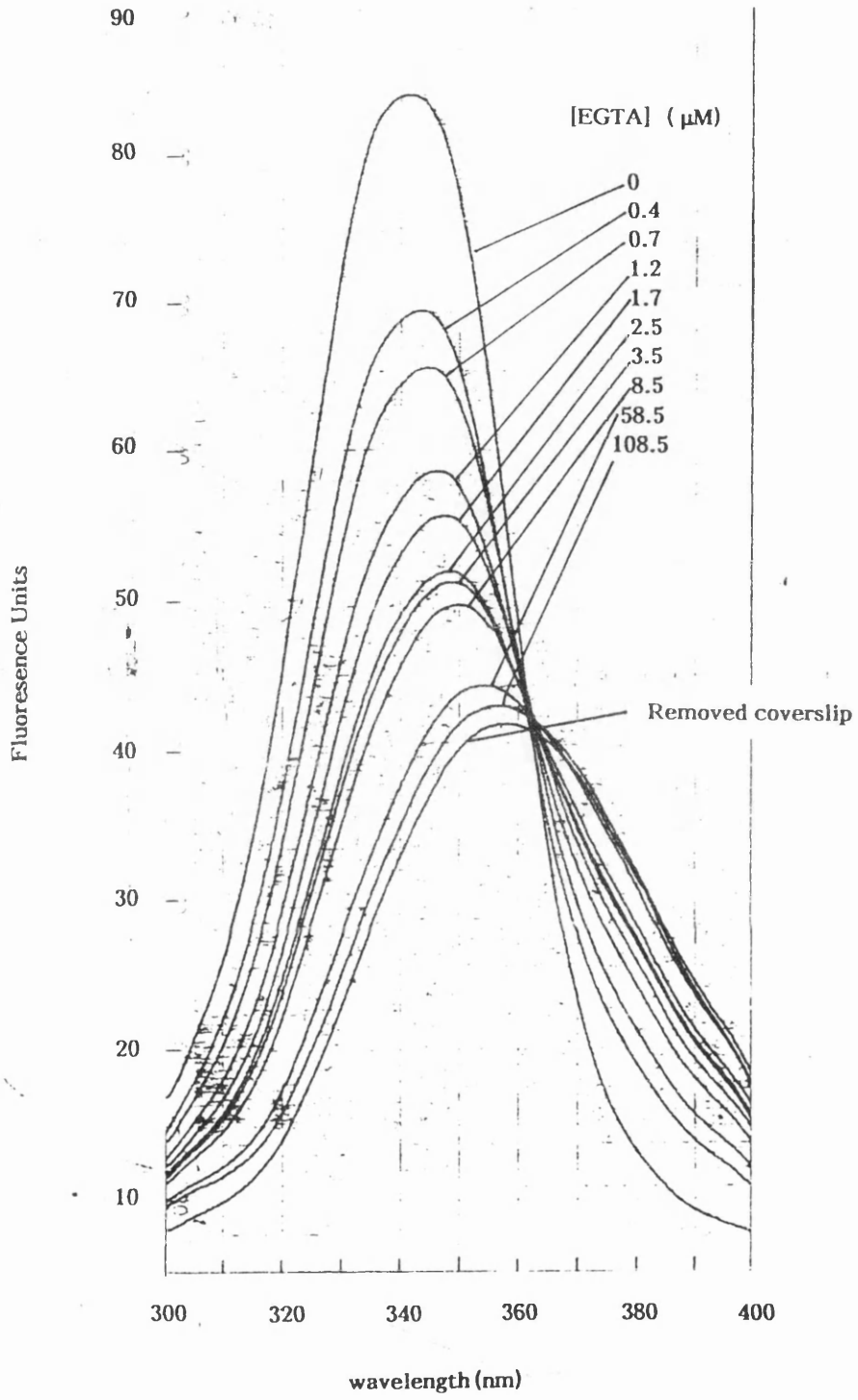
Initial experiments were carried out under static conditions where mixing of the medium was by means of a small magnetic follower (see chapter 2 for more details). Because of the decreased number of cells in the light path, the calcium probe fura 2 was used instead of quin 2. The fluorescence of fura 2 is approximately 30 times brighter than quin 2 (approximately 6 times the absorbance and 5 times the quantum yield), and has been used extensively to monitor calcium fluctuations in single cells (Grynkiewicz et al., 1985). Fig.3.15 shows the emission spectrum of fura 2 ( $1\mu\text{M}$ ) in the absence of cells, measured at 500 nm when excited over the wavelengths 300nm - 400nm. On the progressive addition of EGTA which chelate  $\text{Ca}^{2+}$  ions, the excitation maximum shifted from 340nm to longer wavelengths, with an isosbestic point of 362nm.

In order to assess the effect of fura 2 on steroidogenesis in rat Leydig cells, purified cells were plated onto poly-lysine coated coverslips and then incubated with  $10\mu\text{M}$  fura 2/AM ester for 30min. These cells were then washed with medium and then stimulated with different concentrations of LH. Fig.3.16 shows that fura 2 loading does not have an adverse affect on testosterone production. Also, the poly-lysine did not alter the responsiveness of the cells to LH, when compared with cells plated on plastic culture wells.

In order to test the effectiveness of fura 2, rat and bovine adrenal glomerulosa cells were loaded with fura 2 and then stimulated with either angiotensin II or potassium. In rat glomerulosa cells, angiotensin II ( $10^{-8}\text{M}$ ) stimulated an immediate fluorescence peak which declined over 1.5min to a lower sustained level of fluorescence above basal

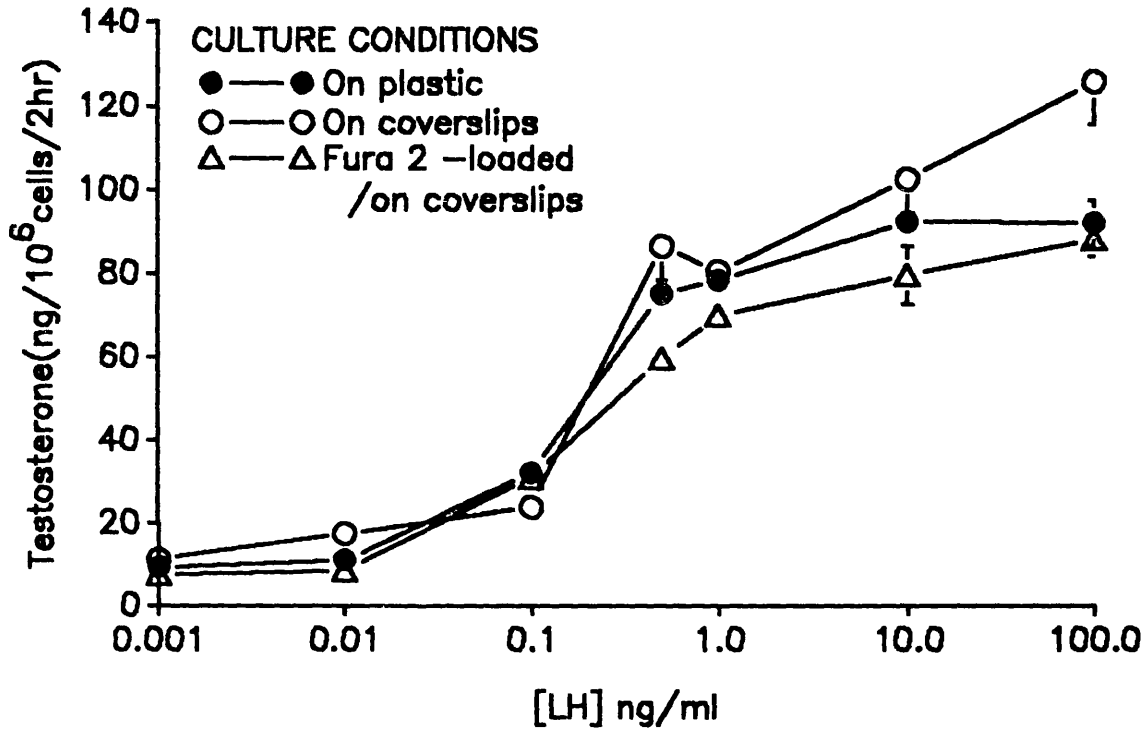
**Fig. 3.15** The effect of chelating calcium with EGTA on the excitation spectrum of fura-2. The addition of EGTA caused fura-2 ( $1\mu\text{M}$ ) to be converted from the  $\text{Ca}^{2+}$ -bound form to the free anionic form. This was accompanied by a shift in the excitation maximum from 340nm to progressively longer wavelengths when monitored at 500nm emission. The spectra were obtained in the presence of a glass-coverslip in the cuvette. The removal of the glass coverslip after the addition of 108.5mM EGTA caused a small drop in the overall fluorescence but did not interfere with the characteristics of the spectrum.

Figure 3.15



**Fig. 3.16** The effect of poly-L-lysine and fura-2 on LH-stimulated testosterone production. Leydig cells ( $2.5 \times 10^5$  cells/ well/ 1ml) were cultured either directly in plastic 24 well plates, or on poly-L-lysine-coated coverslips placed in 24 well plates with and without fura-2/AM ester ( $10\mu\text{M}$ ) for 30mins. These cells were then stimulated with increasing concentrations of LH for 2 hours, and the testosterone produced was determined as described in the Methods. Each point represents the mean  $\pm$  S.E. for triplicate incubations within one of two similar experiments.

Figure 3.16



(Fig.3.17a). When the stimulating agent was  $K^+$  (5.6mM), there was again an immediate increase in fluorescence, but this was followed by a slow decline towards basal levels (Fig.3.17b).

The bovine glomerulosa cells responded to both angiotensin II and  $K^+$  with different profiles compared with the rat glomerulosa cells. On stimulation with angiotensin II ( $10^{-8}M$ ), there was an immediate increase in fluorescence followed by a decline over 2min to basal levels. Subsequent stimulation of the same cells with  $K^+$  (14mM) gave only a small increase in fluorescence (Fig.3.18a). However, if the cells were stimulated first with  $K^+$  (5.6mM) there was an immediate increase in the fluorescence which was maintained at a sustained level above basal; subsequent stimulation with angiotensin II ( $10^{-8}M$ ) caused a fluorescence peak above the  $K^+$  stimulated levels, the fluorescence declined to near basal levels over 2min (Fig.3.18b).

Fig 3.19 shows a typical fluorescence trace of fura 2 loaded Leydig cells on coverslips, when stimulated with LH. It can be seen that there is a constant increase in the basal fluorescence, and the addition of medium or LH (10ng/ml) does not stimulate an increase in the fluorescence. This lack of responsiveness to LH could be explained by a rapid exchange of calcium at the membrane, which would not necessarily give a net increase of calcium within the cells.

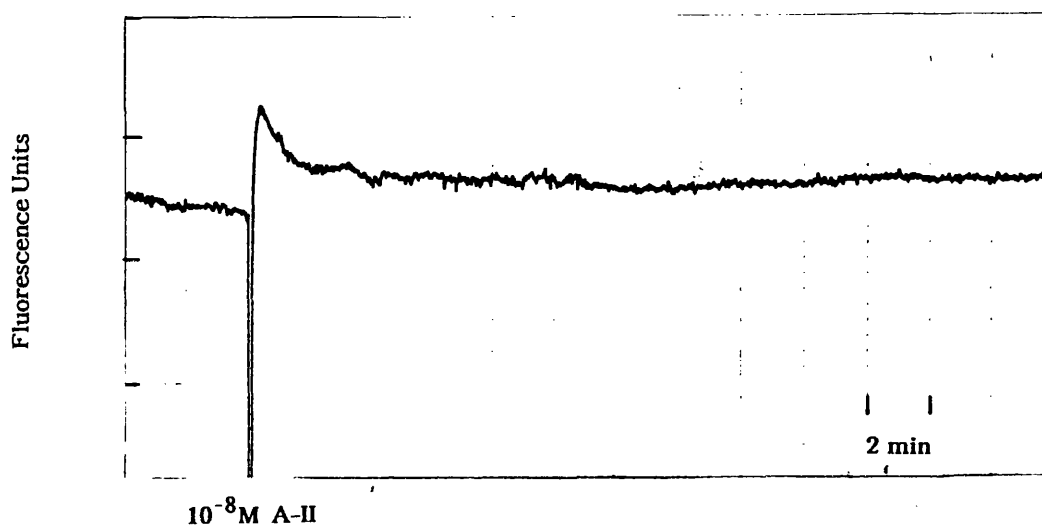
To test this suggestion, the method of "manganese quenching" of the fura 2 signal was used (Hallam et al., 1988). This method is based on the loss of fura 2 fluorescence when fura 2 binds  $Mn^{2+}$  ions. In the presence of  $Mn^{2+}$  in the incubation medium, the stimulation of calcium channels or the addition of calcium ionophore would cause a rapid influx of  $Mn^{2+}$  into the cell, resulting in an immediate decrease in the fura 2 fluorescence. Fig.3.20 demonstrates the effectiveness of fura 2 quenching by  $Mn^{2+}$  on



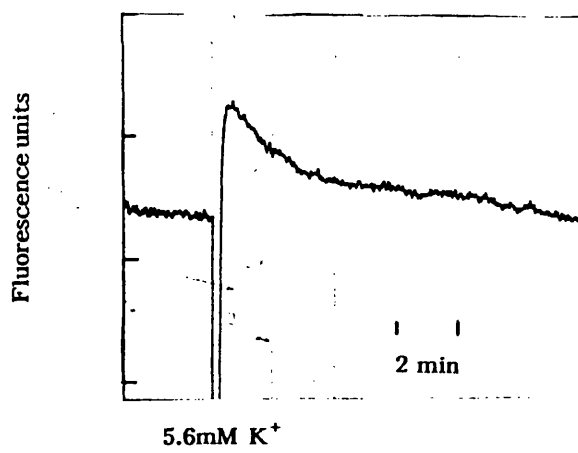
**Fig. 3.17 The effect of angiotensin II and potassium on intracellular Ca<sup>2+</sup> levels in rat adrenal glomerulosa cells.** Rat adrenal glomerulosa cells were loaded with fura-2/AM ester (3μM) for 30mins and than washed twice with a low potassium (3.5mM) simple salts medium. These cells were used at a concentration of 2 X 10<sup>6</sup> cells /ml in a 1ml cuvette with magnetic follower. The cells were excited at 340nm (slit width 4.5nm) and changes in the emission was monitored at 500nm (slit width 9nm). Additions to the cuvette were made in a volume of 10μl to give the concentrations shown. (A) Angiotensin II and (B) potassium were added to the cuvettes to give final concentrations of 10<sup>-8</sup> M and 5.6mM respectively.

Figure 3.17

(A)



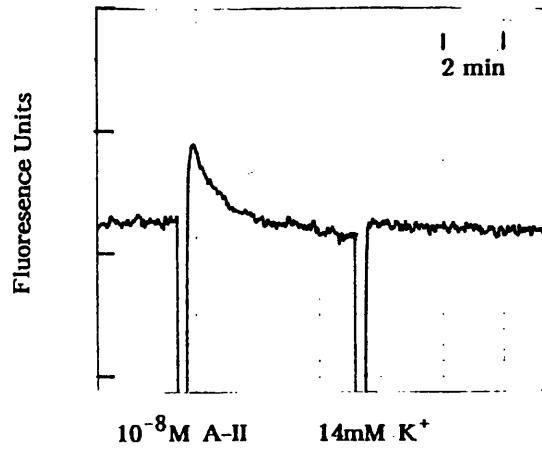
(B)



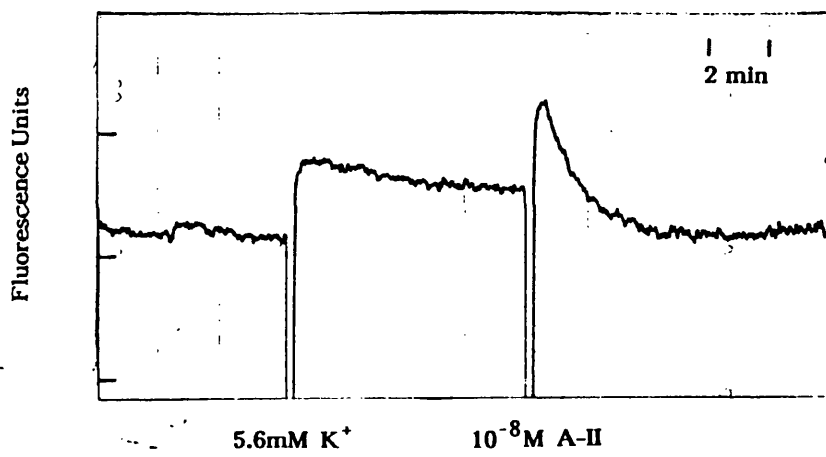
**Fig. 3.18 The effect of angiotensin II and potassium on intracellular  $\text{Ca}^{2+}$  levels in bovine adrenal glomerulosa cells.** Bovine adrenal glomerulosa cells were loaded with fura-2/AM ester ( $3\mu\text{M}$ ) for 30mins and than washed twice with a low potassium ( $3.5\text{mM}$ ) simple salts medium. These cells were used at a concentration of  $2 \times 10^6$  cells /ml in a 1ml cuvette with magnetic follower. The cells were excited at 340nm (slit width 4.5nm) and changes in the emission was monitored at 500nm (slit width 9nm). Additions to the cuvette were made in a volume of  $10\mu\text{l}$  to give the concentrations shown. **(A)** Angiotensin II ( $10^{-8}$  M) and potassium ( $14\text{mM}$ ) were added to the cuvette sequentially. **(B)** Potassium ( $5.6\text{mM}$ ) followed by angiotensin II ( $10^{-8}$  M) were added to the cuvette and the fluorescence monitored.

Figure 3.18

(A)

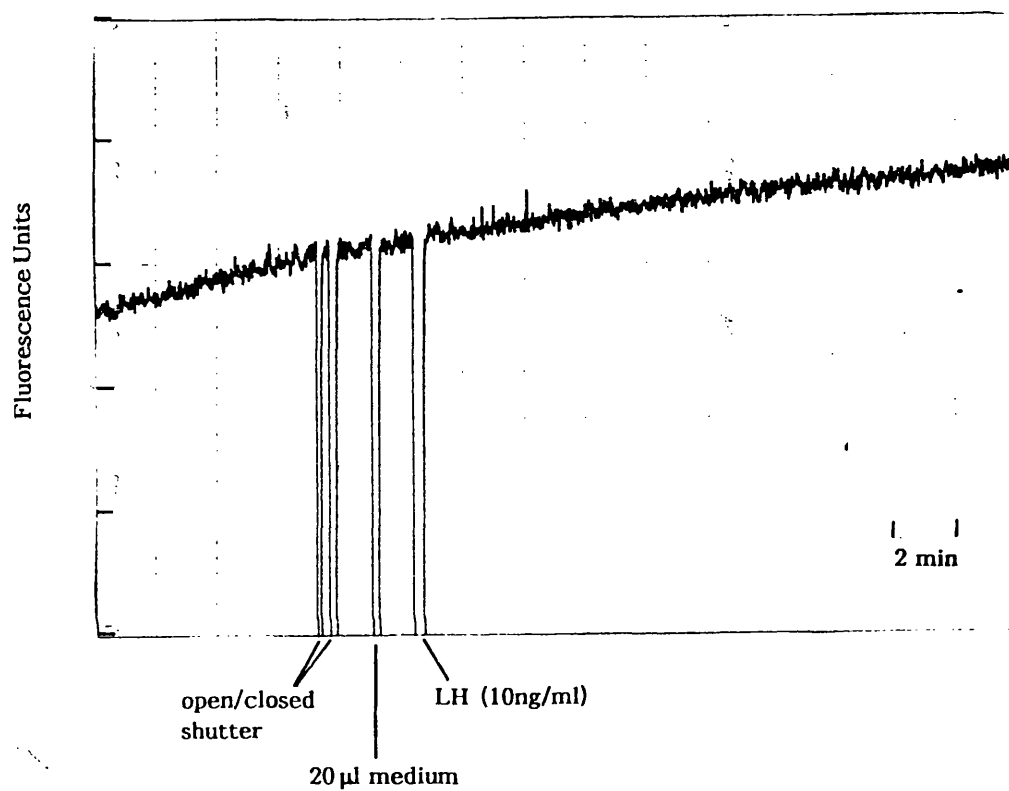


(B)



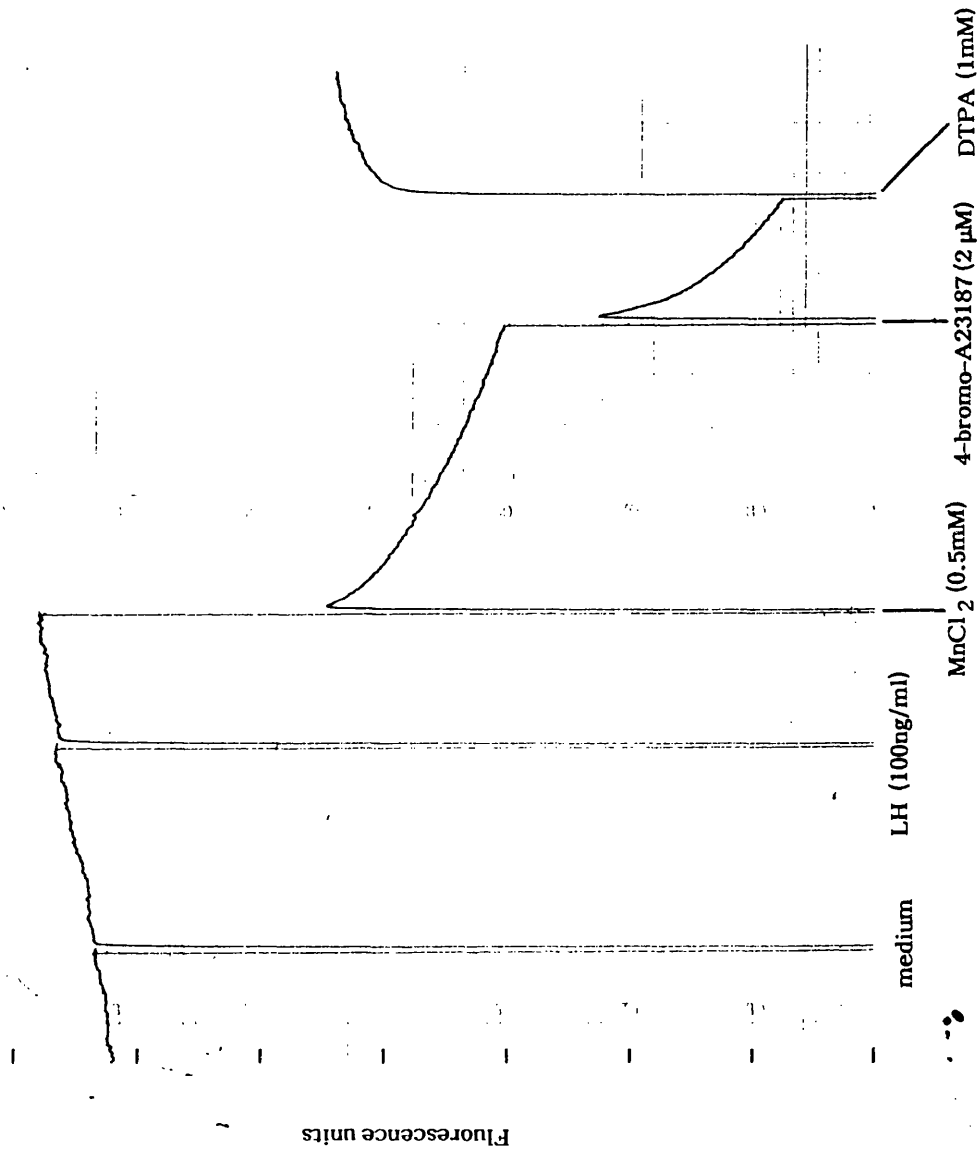
**Fig. 1.19 Effect of LH-stimulation on the fluorescence of fura-2 in rat Leydig cells on poly-L-lysine-coated glass coverslips.** Leydig cells ( $3 \times 10^6$  cells/ coverslip) were loaded with fura-2/AM ( $5\mu\text{M}$ ) for 45mins and than washed twice in large volumes of simple salts solution. The coverslip was placed diagonally in a square (3ml) cuvette and held between two split-Teflon rings. The bathing solution was mixed by a magnetic follower at the bottom of the cuvette. The fluorescence emission was monitored at 500nm with excitation at 340nm. Additions to the cuvette were made in a volume of  $20\mu\text{l}$  give the final concentrations shown. LH was added to give a final concentration of 10ng/ml.

Figure 3.19



**Fig. 3.20** The quenching of fura-2 fluorescence by manganese ions in rat Leydig cells on poly-L-lysine-coated coverslips. Leydig cells ( $3 \times 10^6$  cells/ coverslip) were loaded with fura-2/AM ( $5\mu\text{M}$ ) for 45mins and than washed twice in large volumes of a simple salts solution. The coverslip was placed diagonally in a square (3ml) cuvette and held in place between two split-Teflon rings. The bathing solution was mixed by a magnetic follower at the bottom of the cuvette. The fluorescence emission was monitored at 500nm with excitation at 340nm. Additions to the cuvette were made in a volume of  $20\mu\text{l}$  give the final concentrations shown. The calcium ionophore, 4-bromo-A23187 ( $2\mu\text{M}$ ), allowed  $\text{Mn}^{2+}$  ions to enter the cells, and was used as a positive control to show the ability of manganese to quench the fluorescence of intracellular fura-2. DTPA was added to chelate extracellular  $\text{Mn}^{2+}$  ions.

Figure 3.20





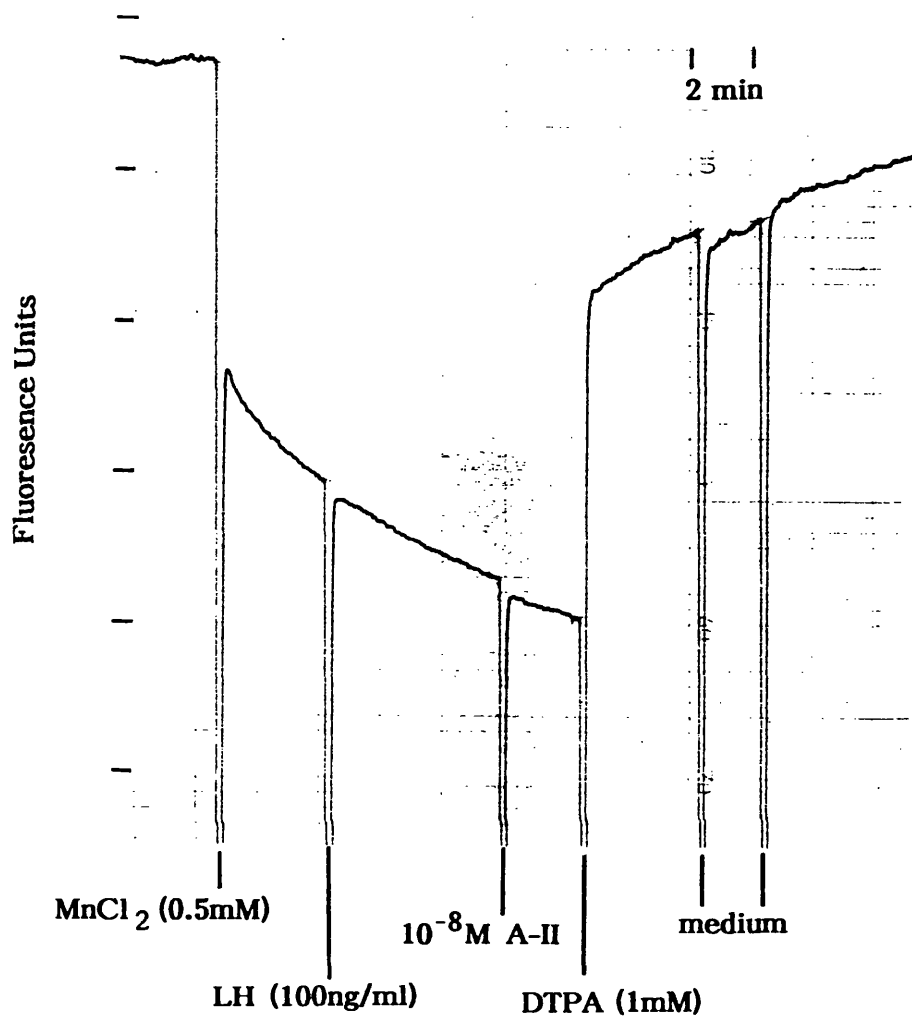
stimulation with the calcium ionophore 4-bromo-A23187. These cells did not respond to LH stimulation, and the addition of  $Mn^{2+}$  (0.5mM) caused an immediate fall in fura 2 fluorescence, as the extracellular fura 2 complexed with  $Mn^{2+}$  ions. This was followed by a slow decline of the intracellular fura 2 fluorescence as  $Mn^{2+}$  slowly entered the cells. On the addition of 4-bromo-A23187 (2 $\mu$ M) there was an immediate fall in fluorescence as the intracellular fura 2 complexed with the influx of  $Mn^{2+}$  ions. The addition of DTPA (1mM), which has a high affinity for  $Mn^{2+}$ , restored the extracellular fura 2 signal.

The above method was then applied to stimulation of the cells with LH instead of 4-bromo-A23187 (Fig.3.21). Again the addition of  $Mn^{2+}$  (0.5mM) caused the immediate loss of the extracellular fura 2 signal followed by a slower decline of the intracellular signal. However, stimulation with LH (100ng/ml) or angiotensin II ( $10^{-8}$ M) did not cause a sudden quenching of the fura 2 signal. The extracellular fura 2 signal was recovered on addition of DTPA (1mM), and this was followed by a slow recovery of the intracellular fura 2 signal as  $Mn^{2+}$  moved out of the cells. These experiments suggested that LH did not stimulate entry of extracellular calcium into the cells. However, because of the rapid loss of fura 2 from the cells, any small changes in fluorescence may be masked.

It has been shown in other cells that fura 2 was actively removed from cells, and this could be inhibited by the inclusion of probenecid in the medium. It was found that probenecid did prevent leakage of fura 2 from Leydig cells, but there was still no observable stimulation with LH (100ng/ml) (Fig.3.22). Because of the high level of probenecid that was required, there was the possibility of toxicity. Therefore, a superfusion system was developed to continuously remove the fura 2 from the medium

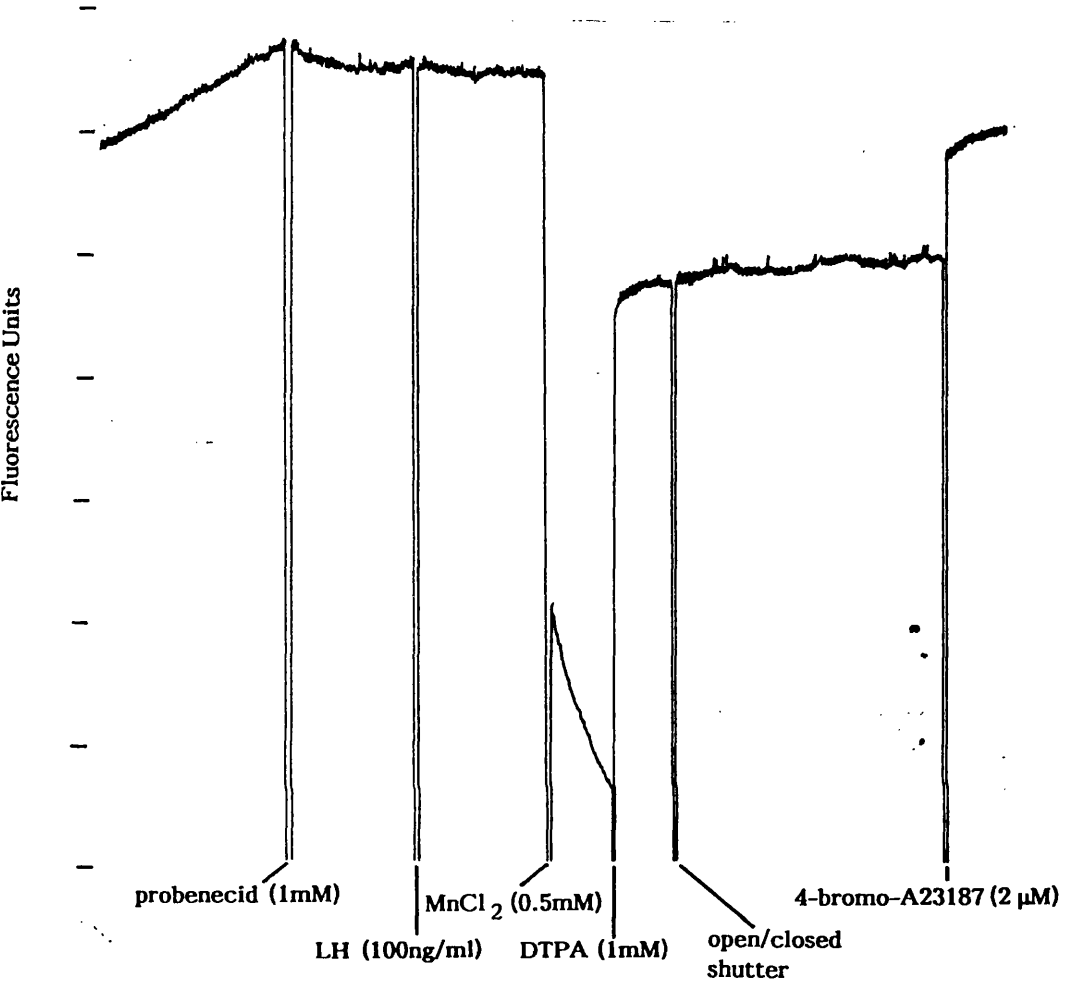
**Fig. 3.21 The effect of manganese ions on intracellular fura-2 fluorescence in Leydig cells stimulated with LH and angiotensin II.** Leydig cells ( $3 \times 10^6$  cells/ coverslip) were loaded with fura-2/AM ( $5\mu\text{M}$ ) for 45mins and than washed twice in large volumes of a simple salts solution. The coverslip was placed diagonally in a square (3ml) cuvette and held in place between two split-Teflon rings. The bathing solution was mixed by a magnetic follower at the bottom of the cuvette. The fluorescence emission was monitored at 500nm with excitation at 340nm. Additions to the cuvette were made in a volume of  $20\mu\text{l}$  to give the concentrations shown. LH (100ng/ml) and angiotensin II ( $10^{-8}$  M) were added in the presence of manganese to investigate possible stimulation of divalent ion influx by these compounds. DTPA was added to chelate extracellular  $\text{Mn}^{2+}$  ions.

Figure 3.21



**Fig. 3.22** The effect of probenecid, an inhibitor of anion transport, on fura-2 fluorescence in LH-stimulated Leydig cells. Leydig cells ( $3 \times 10^6$  cells/ coverslip) were loaded with fura-2/AM ( $5\mu\text{M}$ ) for 45mins and than washed twice in large volumes of a simple salts solution. The coverslip was placed diagonally in a square (3ml) cuvette and held in place between two split-Teflon rings. The bathing solution was mixed by a magnetic follower at the bottom of the cuvette. The fluorescence emission was monitored at 500nm with excitation at 340nm. Additions to the cuvette were made in a volume of  $20\mu\text{l}$  to give the concentrations shown. Probenecid was added to inhibit the leakage of fura-2 from the cells.

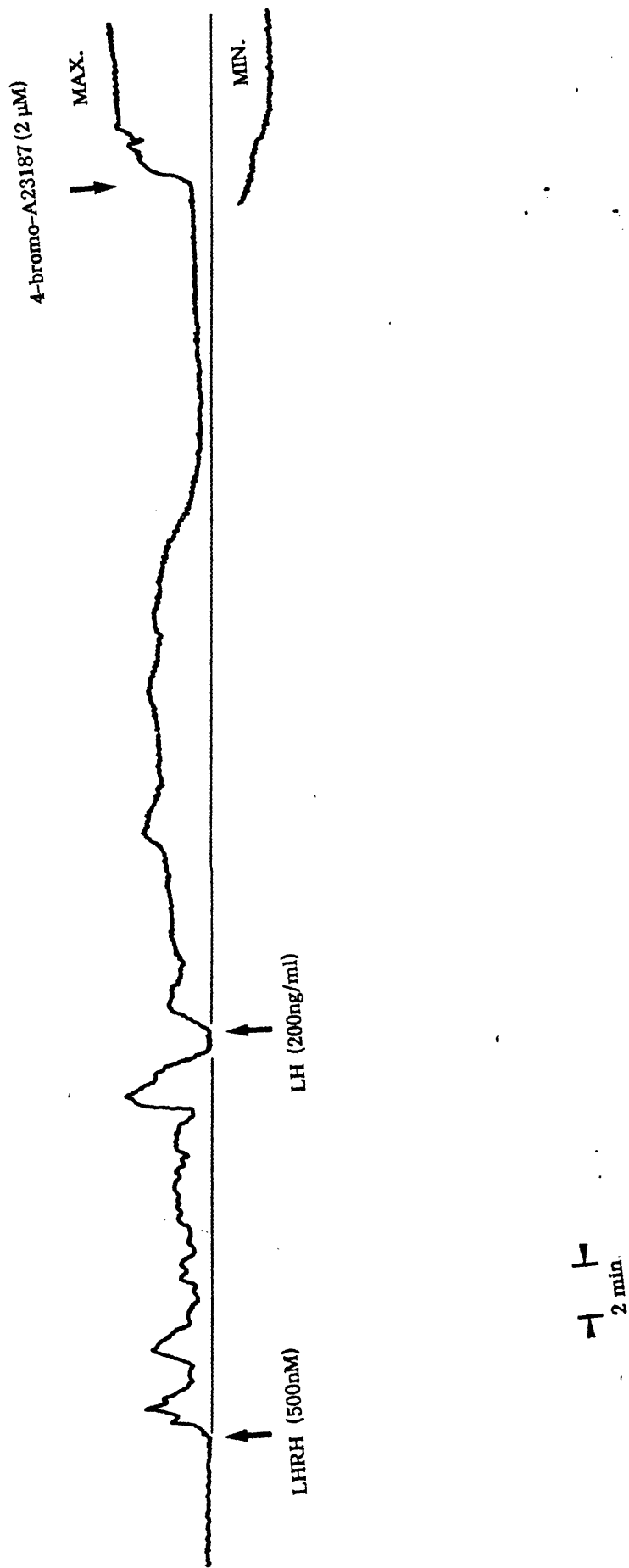
Figure 3.22



within the cuvette. Using this superfusion system it was possible on two separate occasions to detect a stimulation of fura 2 fluorescence by LH and LHRH (Fig.3.23 and 3.24). However, a lack of responsiveness to LH stimulation was the normal observation.

**Fig. 3.23** The measurement of fura-2 fluorescence in a superfused cuvette. Leydig cells ( $3 \times 10^6$  cells/ coverslip) were loaded with fura-2/AM ( $5\mu\text{M}$ ) for 45mins and then washed twice in large volumes of a simple salts solution. The coverslip was placed diagonally in a square (3ml) cuvette and held in place between two split-Teflon rings. The bathing solution ( $34^\circ\text{C}$ ) was changed continuously by means of a peristaltic pump. All additions were made by changing the superfusion medium to one containing the required concentration of stimulus ie. LHRH ( $500\text{nM}$ ) and LH ( $200\text{ng/ml}$ ). The fluorescence emission was monitored at  $500\text{nm}$  with excitation at  $340\text{nm}$ .

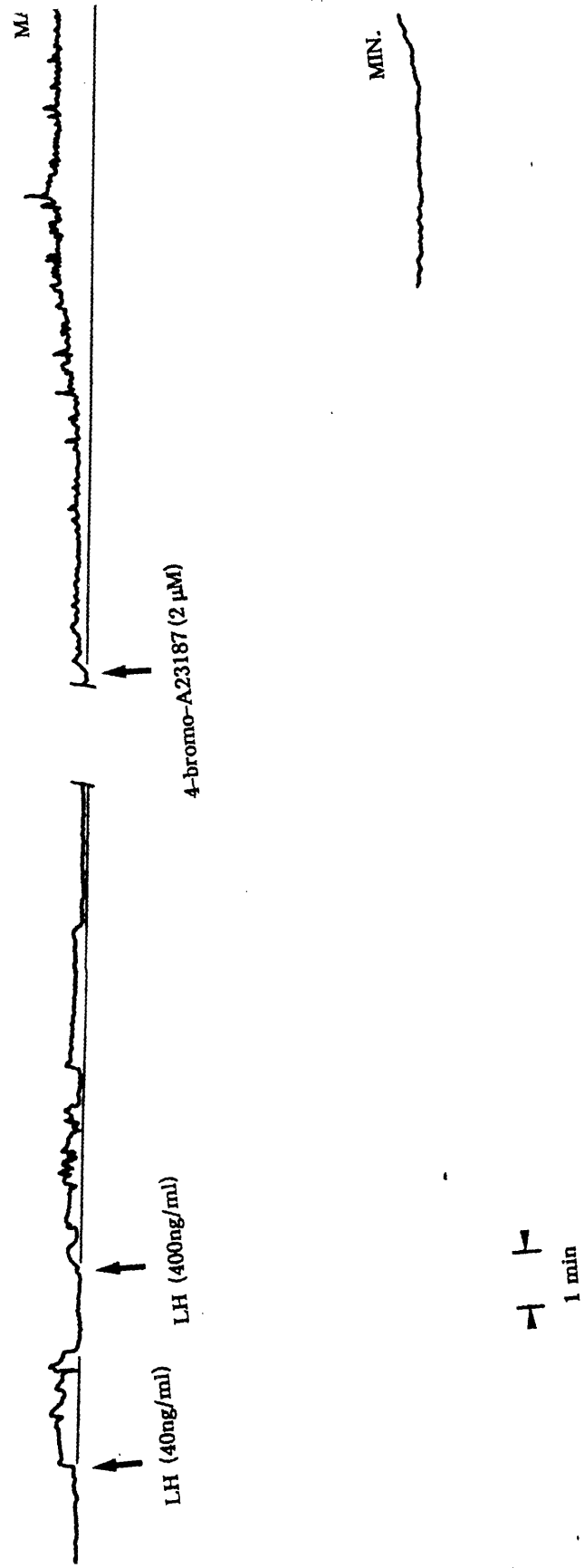
Figure 3.23





**Fig. 3.24** The measurement of fura-2 fluorescence in a superfused cuvette, another example of LH-stimulated fluorescence increase. Leydig cells ( $3 \times 10^6$  cells/ coverslip) were loaded with fura-2/AM ( $5\mu\text{M}$ ) for 45mins and than washed twice in large volumes of a simple salts solution. The coverslip was placed diagonally in a square (3ml) cuvette and held in place between two split-Teflon rings. The bathing solution ( $34^\circ\text{C}$ ) was changed continuously by means of a peristaltic pump. All additions were made by changing the superfusion medium to one containing the required concentration of stimulus. The fluorescence emission was monitored at 500nm with excitation at 340nm.

Figure 3.24



### **3.3 DISCUSSION**

These results demonstrate the importance of calcium in the regulation of steroidogenesis in rat Leydig cells. In agreement with previous work, the removal of extracellular calcium resulted in approximately 50% loss of LH-stimulated testosterone production, without altering the ED<sub>50</sub> for LH (Janszen et al., 1976; Moger, 1983). The removal of extracellular also inhibited 8-bromo-cyclic AMP-stimulated testosterone production, indicating the site of calcium requirement in steroidogenesis to be distal to cyclic AMP production. Furthermore, the conversion of 22(R)OH-cholesterol to testosterone was unaffected by the removal of extracellular calcium, suggesting the site of calcium requirement to a site between cyclic AMP and cholesterol side-chain cleavage. This is in accord with the suggestion by Hall et al., (1981) that calcium and the calcium binding protein calmodulin are involved in the mechanism by which LH stimulates Leydig cell steroidogenesis at the point of cholesterol transport into the mitochondria.

Previous work have shown that LH will increase intracellular calcium in rat Leydig cells and bovine luteal cells (Sullivan and Cooke, 1986; Davis et al., 1987; Alila et al., 1989). However, in rat Leydig cells it has not been established whether LH causes intracellular calcium mobilization or solely extracellular calcium entry. The present results with lanthanum, a competitive inhibitor of calcium entry into cells, indicate that influx of calcium from the extracellular medium is required for maximum steroid production. Of especial interest is that even at 1000 $\mu$ M lanthanum, the inhibition of dibutyryl cyclic AMP-stimulated testosterone production did not exceed that caused by the removal of extracellular calcium. This suggests that only approximately 50% of cyclic AMP-stimulated steroidogenesis requires extracellular calcium entry.

The effect of lanthanum on the action of LH was a little more complicated, since

lanthanum inhibited both LH-stimulated cyclic AMP and testosterone production. The results demonstrated that LH-stimulated cyclic AMP production in rat Leydig cells was calcium-dependent. In support of this it was found that the removal of extracellular calcium also caused a decrease in cyclic AMP production stimulated by LH (10 and 100ng/ml). Also, in later experiments it was found that cyclic AMP production stimulated with cholera toxin and forskolin were also inhibited by the exclusion of extracellular calcium from the incubation medium (see chapter 4). The inhibition of LH (0.1, 0.5 and 1.0ng/ml)-stimulated testosterone by lanthanum (250 $\mu$ M) could be accounted for by the inhibition of cyclic AMP production, since cyclic AMP levels were undetectable. But at higher concentrations of LH (10 and 100ng/ml) the testosterone production was approximately 50% of the control levels despite near basal cyclic AMP levels. This gives support to the believe that only very low levels of cyclic AMP are required to stimulate steroidogenesis. These results also indicate that the residual testosterone production that is not sensitive to extracellular calcium removal, is cyclic AMP-dependent.

Therefore the inhibitory effect of lanthanum on testosterone production is primarily at the same site where the removal of extracellular calcium interferes with Leydig cell steroidogenesis, that is between cyclic AMP formation and cholesterol side-chain cleavage.

The dihydropyridine calcium antagonists (eg. nifedipine) have been used extensively to show the involvement of voltage-dependent calcium channels in the control of calcium entry into cells (Hess et al., 1984). At nanomolar concentrations they have been shown to inhibit L-type calcium channels, and T-type calcium channels at low micromolar concentrations (Aguilera and Catt, 1986; Cohen et al., 1988). In the adrenal glomerulosa

cell, aldosterone production stimulated by angiotensin II and potassium have been linked to the activation of T-type calcium channels, and full inhibition of aldosterone production can be obtained with approximately  $10\mu\text{M}$  nifedipine. In contrast, both 8-bromo-cyclic AMP- and ACTH-stimulated aldosterone production were not inhibited by  $10\mu\text{M}$  nifedipine, and were only partially inhibited by  $50\mu\text{M}$  (Aguilera and Catt, 1986). Similarly, nifedipine inhibited LH-stimulated testosterone production with an  $\text{ID}_{50}$  dose of  $50\mu\text{M}$ , and no inhibition was seen with  $10\mu\text{M}$ . This suggested that L- and T-type voltage-dependent calcium channels are not involved in Leydig cell steroidogenesis. The results also showed that the inhibition of steroidogenesis by nifedipine ( $50\mu\text{M}$ ) was not due to the inhibition of calcium entry, since the same inhibitory effect of nifedipine was obtained in calcium-free medium.

It is possible that calcium entry in Leydig cells may occur via the sodium-calcium exchanger, since an inhibitor of this exchanger, verapamil ( $10\mu\text{M}$ ), inhibited steroidogenesis in rat Leydig cells (Lin et al., 1979). However, in mouse Leydig cells, verapamil and related inhibitors were shown to be non-specific in their inhibitory action and only partially inhibited steroidogenesis at  $100\mu\text{M}$ , with no inhibition at  $10\mu\text{M}$  (Moger, 1983). In rat adrenal glomerulosa cells and human neutrophils, the sodium-calcium exchanger have been shown to be very important in the maintenance of the basal cytosolic calcium concentration, and lanthanum was shown to inhibit calcium entry via this exchanger (Simchowitz and Cragoe, 1988; Hunyady et al.1988). It is possible that the maintenance of basal calcium levels are essential for maximum stimulation of steroidogenesis by LH/cyclic AMP in rat Leydig cells. This possibility is supported by the inhibitory effect of A23187 and thapsigargin on LH- and dibutyryl cAMP-stimulated testosterone production. It appears that the rat Leydig cells maintain an optimum level

of intracellular calcium for the regulation of steroidogenesis, such that elevated levels of calcium are not stimulatory.

The involvement of intracellular pools of calcium in LH- and dibutyryl cyclic AMP-stimulated steroidogenesis was suggested by the results obtained with TMB-8. It would appear that TMB-8 inhibited both LH- and dibutyryl cyclic AMP-stimulated testosterone production at a common site, since the  $ID_{50}$  for TMB-8 was the same ( $50\mu M$ ). However, recent evidence has shown TMB-8 to be cell specific in its effects on intracellular calcium levels, and could be due to inhibition of plasma membrane calcium entry (Chiou and Maglagodi, 1975; Pain-Smith et al., 1988; Schumaker and Sze, 1987).

The results obtained with fura 2 loaded rat and bovine adrenal glomerulosa cells show the effectiveness of fura 2 in reporting intracellular calcium changes in response to stimulation with angiotensin II and potassium. These observations are in agreement with those found by other workers in the field (Capponi et al., 1984, 1987; ). It is of interest to note from previous work that aldosterone production in bovine glomerulosa cells in response to angiotensin II or potassium, can be mimicked using a combination of calcium ionophore (A23187) and phorbol ester (PMA) (Blum and Conn, 1982; Barrett et al., 1986; Kojima et al., 1985). The involvement of phospholipase C (PLC) and the subsequent release of 1,4,5-trisphosphoinositol ( $IP_3$ ), diacylglycerol (DAG) and the activation of protein kinase C (PKC) in the action of angiotensin II, have been clearly demonstrated (Barrett et al., 1989). Therefore it is possible to conclude from the abundant evidence that the "Calcium pathway" is capable of stimulating steroidogenesis, at least in adrenal glomerulosa cells.

Previous evidence using quin 2 loaded rat Leydig cells, demonstrated the ability of LH to increase intracellular calcium with a lag period of 2 min. after the addition of LH

(Sullivan and Cooke, 1986). However, it has not been possible to mimic LH-stimulated testosterone production using A23187 or PMA (Lin et al., 1980). These results suggest that the involvement of calcium in steroidogenesis is not through an independent pathway, but may possibly augment the action of the cyclic AMP-dependent pathway, because both LH- and 8-bromo-cyclic AMP-stimulated testosterone production is similarly inhibited by the removal of extracellular calcium.

The ability of LH to stimulate calcium changes in rat Leydig cells is also supported by  $^{45}\text{Ca}^{2+}$  efflux studies (Platts et al., 1986). It was demonstrated that LH stimulated a dose-dependent efflux of  $^{45}\text{Ca}^{2+}$  from pre-labelled rat Leydig cells. However, the present study using the fluorescent calcium chelator fura 2 did not yield conclusive results. But there was leakage of fura 2 from the cells and this caused a steady increase in the background fluorescence, which may have masked any small changes in the intracellular calcium.

In bovine glomerulosa cells stimulated with angiotensin II, it has been shown that after the initial calcium spike due to  $\text{IP}_3$  mediated intracellular calcium release, there follows a sustained entry of extracellular calcium concomitant with an increased efflux of calcium from the cells, resulting in a steady-state intracellular calcium level that is similar to basal levels. LH may be stimulating a similar sustained calcium exchange in rat Leydig cells. However, the results obtained using the method of "manganese quenching" to demonstrate LH-stimulated entry of bivalent-cations into rat Leydig cells, suggest that this does not occur. This suggests that the extracellular calcium required for maximal steroidogenesis is not regulated by LH, and that the maintenance of basal calcium levels may be essential.

The stimulation of an increase in fura 2 fluorescence by LH in superfused Leydig

cells supports previous results, but in contrast to quin 2 loaded cells there was no lag period of 2 min.. However, these were not consistent results, and in other experiments LH did not stimulate an increase in fura 2 fluorescence.

In conclusion these results give further support for the involvement of calcium in steroidogenesis in rat Leydig cells. The primary site of calcium requirement in steroidogenesis is after cyclic AMP production and prior to the conversion of cholesterol to testosterone production. LH-stimulated cyclic AMP production is also dependent on extracellular calcium, and is inhibited by the addition of lanthanum to the incubation medium. The proposed role of calcium as an independent messenger system for LH-stimulated steroidogenesis in rat Leydig cells is doubtful, since neither the calcium ionophore A23187 or thapsigargin can mimic the stimulatory action of LH. However, the evidence shows that calcium is required for the full stimulation of steroidogenesis by cyclic AMP, and the intracellular calcium level appears to be optimally regulated. The regulation of this calcium requirement does not appear to be via voltage-dependent calcium channels.



## **CHAPTER FOUR**

The Effect of Calmidazolium, a Calmodulin inhibitor,  
on Testosterone Production

## 4.1 INTRODUCTION

Calmodulin is a ubiquitous calcium binding protein that is involved in the regulation of a wide spectrum of cellular processes. It is the major sensor for the translation of intracellular calcium changes into a biochemical signal essential to the regulation of many target enzymes (Cheung, 1980; Klee and Vanaman, 1982; Wang et al., 1985). In order to elucidate the mechanisms of calmodulin action, wide use of calmodulin antagonists have been made (Roufogalis, 1985). One of these that has been used frequently and which binds with high affinity to calmodulin (Van Belle, 1981; Sobieszek, 1989), is calmidazolium (compound R 24571, 1-[bis(p-chlorophenyl) methyl]-3-[2,4-dichloro- $\beta$ -(2,4-dichlorobenzyloxy)phenethyl] imidazoliumchloride). Previous work carried out in this laboratory (Sullivan and Cooke, 1985) showed that a variety of calmodulin antagonists, including calmidazolium, inhibit LH-stimulated cyclic AMP production and LH- and LH releasing hormone (LHRH)-stimulated testosterone production in rat Leydig cells. In chapter 3 it was shown that the exclusion of extracellular  $\text{Ca}^{2+}$  from the incubation medium, led to a decrease in cyclic AMP production. The addition of a competitive calcium antagonist,  $\text{La}^{3+}$ , also markedly decreased LH-stimulated cyclic AMP production. Together, these observations suggest that in this cell type there is a requirement for  $\text{Ca}^{2+}$ -calmodulin in the LH-stimulated synthesis of cyclic AMP. Recent studies on the production of cyclic AMP in isolated plasma membranes from rat thymocytes and Y-1 mouse adrenal tumour cells (Segal, 1989; Papadopoulos et al., 1990), also give support for the involvement of calmodulin in trophic hormone-stimulated cyclic AMP production.

The aim of this work was to further investigate this hypothesis, using the calmodulin antagonist, calmidazolium, and also the removal of  $\text{Ca}^{2+}$  from the incubation

medium. In order to localize the site of  $\text{Ca}^{2+}$ -calmodulin requirement, stimulants (forskolin, cholera toxin, LH) that act at different sites in the plasma membrane to stimulate cyclic AMP synthesis were used.

In the course of the investigations it was unexpectedly found that calmidazolium by itself, has a marked stimulatory effect on steroidogenesis. This effect is over dose range of 1 - 10 $\mu\text{M}$ . These same doses markedly inhibited basal cyclic AMP production. The mechanism of action of calmidazolium on steroidogenesis was therefore also investigated and compared with that for LH and cyclic AMP. The results obtained indicate that it may have a common site of action with LH but by-passes the steps requiring cyclic AMP, calcium, and protein synthesis. Furthermore, calmidazolium also stimulated steroid production in other steroidogenic cells. Therefore, calmidazolium may stimulate processes involved in steroid production, which are common to all steroidogenic cells.

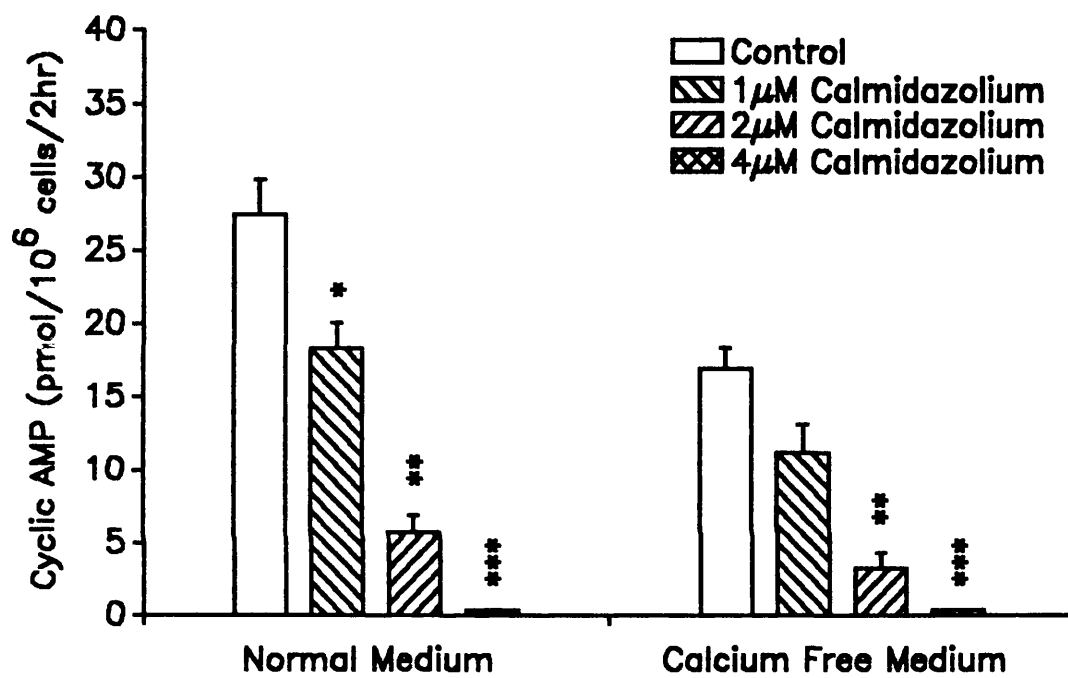
## **4.2 RESULTS**

### **4.2.1. Effect of calmidazolium on cyclic AMP production**

The effect of calmidazolium on basal cyclic AMP production was investigated. The phosphodiesterase inhibitor, IBMX, was added to the incubation medium to prevent the degradation of cyclic AMP to 5'-AMP, this was done because the basal cyclic AMP level is normally very low and sometimes undetectable. Under these conditions, the basal cyclic AMP production was dose-dependently inhibited by calmidazolium (fig. 4.1). The exclusion of extracellular calcium from the incubation medium decreased the basal cyclic

**Fig. 4.1 Effect of calmidazolium on basal cyclic AMP production in the presence and absence of extracellular calcium.** Leydig cells ( $2 \times 10^4$  cells/ well/  $200\mu\text{l}$ ) were incubated for 2 hours in the absence and presence of increasing concentrations of calmidazolium. The cyclic AMP produced was measured as described in the Methods. Each point represents the mean  $\pm$  S.E. for triplicate incubations within one of two similar experiments. (\* P < 0.05; \*\* P < 0.01; \*\*\* P < 0.001, similar to control)

Figure 4.1



AMP levels by approx. 50%, and the addition of calmidazolium further decreased the cyclic AMP production.

Similar experiments were performed to investigate the effect of calmidazolium and the exclusion of extracellular calcium on receptor mediated cyclic AMP production. LH-stimulated cyclic AMP production was inhibited by calmidazolium (fig. 4.2), with  $ID_{50}$  of approx.  $2\mu\text{M}$ .

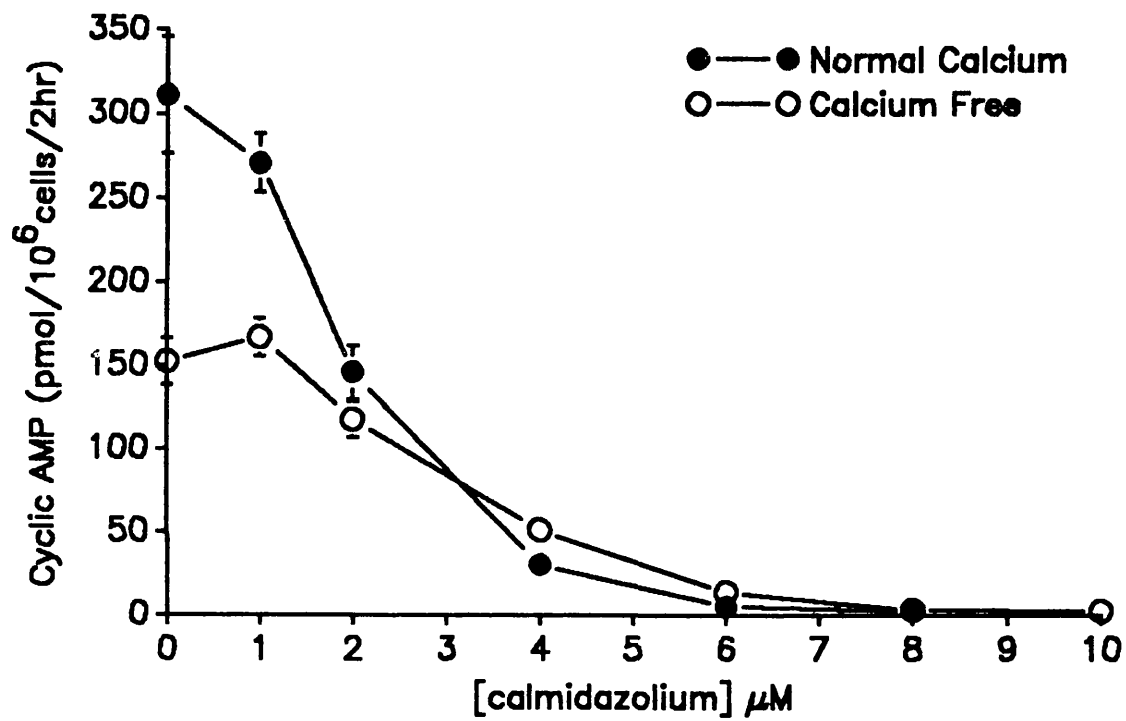
The stimulation of cyclic AMP production via LH/HCG-binding to its receptor is mediated by G-protein(s) (Cooke, 1983). The direct activation of this class of G-protein(s), can be achieved by the use of cholera toxin. Using this approach, it may be possible to investigate whether the site of calmidazolium inhibition is distal to receptor-binding. The cholera toxin-stimulated cyclic AMP was found to be inhibited by calmidazolium with an  $ID_{50}$  of approx.  $1\mu\text{M}$  (fig.4.3). The exclusion of extracellular calcium from the incubation medium caused a 50% inhibition of cyclic AMP production which was similar to that found for the inhibition of the basal and LH-stimulated levels.

The stimulation of cyclic AMP production in Leydig cells can also be achieved with forskolin. This compound has been suggested to stimulate directly the synthesis of cyclic AMP via interaction with the catalytic sub-unit of the adenylate cyclase enzyme (Seamon & Daly, 1981), but its precise mechanism of action is uncertain (Stengel et al., 1982; Birnbaumer et al, 1985; Krall and Jamgotchian, 1987; Yanagibashi et al.,1989). The  $ID_{50}$  of inhibition by calmidazolium was approx.  $1\mu\text{M}$ , which was similar to that found with cholera toxin-stimulation (fig.4.4). Forskolin-stimulated cyclic AMP production was extremely sensitive to the exclusion of extracellular calcium, being inhibited by 80%.

These results suggest that in Leydig cells the most probable site for the involvement of  $\text{Ca}^{2+}$ /calmodulin in cyclic AMP production, is the adenylate cyclase enzyme itself.

**Fig. 4.2 Effect of calmidazolium on LH-stimulated cyclic AMP production in the presence and absence of extracellular calcium.** Leydig cells ( $2 \times 10^4$  cells/ well/  $200\mu\text{l}$ ) were incubated for 2 hours in the absence and presence of increasing concentrations of calmidazolium, and stimulated with LH (100ng/ml). The cyclic AMP produced was measured as described in the Methods. Each point represents the mean  $\pm$  S.E. for triplicate incubations within one of two similar experiments.

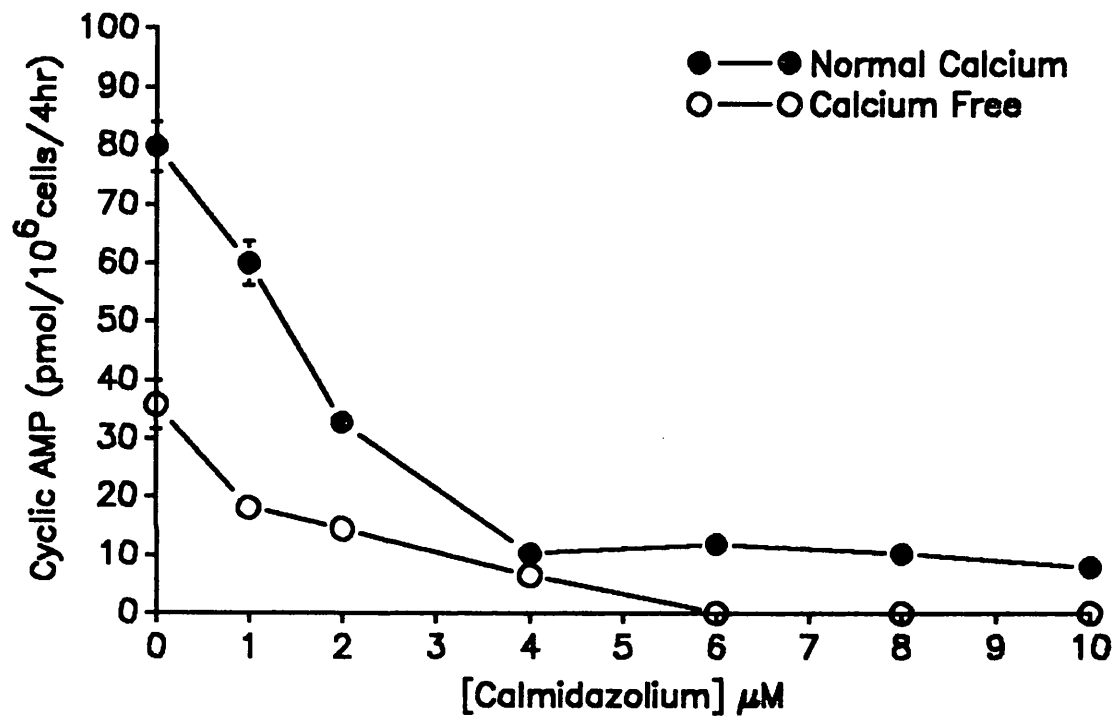
Figure 4.2





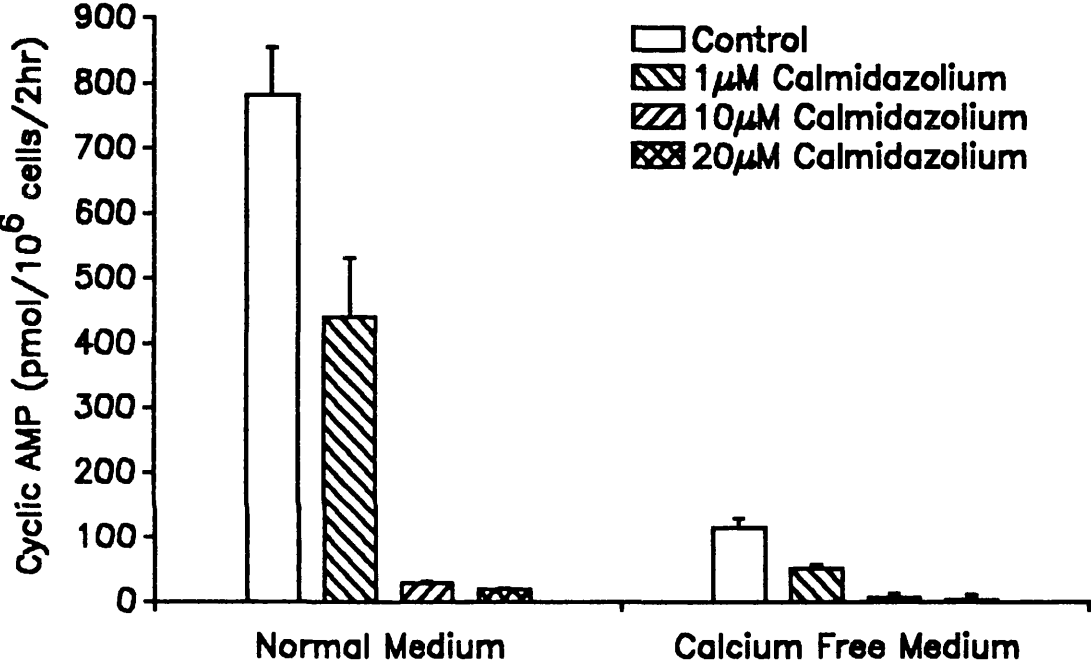
**Fig. 4.3 Effect of calmidazolium on cholera toxin-stimulated cyclic AMP production in the presence and absence of extracellular calcium.** Leydig cells ( $2 \times 10^4$  cells/ well/  $200\mu\text{l}$ ) were incubated for 2 hours in the absence and presence of increasing concentrations of calmidazolium, and stimulated with cholera toxin ( $25\mu\text{g/ml}$ ). The cyclic AMP produced was measured as described in the Methods. Each point represents the mean  $\pm$  S.E. for triplicate incubations within one of two similar experiments.

Figure 4.3



**Fig. 4.4 Effect of calmidazolium on forskolin-stimulated cyclic AMP production in the presence and absence of extracellular calcium.** Leydig cells ( $2 \times 10^4$  cells/ well/  $200\mu\text{l}$ ) were incubated for 2 hours in the absence and presence of increasing concentrations of calmidazolium, and stimulated with forskolin ( $10\mu\text{M}$ ). The cyclic AMP produced was measured as described in the Methods. Each point represents the mean  $\pm$  S.E. for triplicate incubations within one of two similar experiments.

Figure 4.4



#### 4.2.2. Effect of Calmidazolium on Testosterone Production

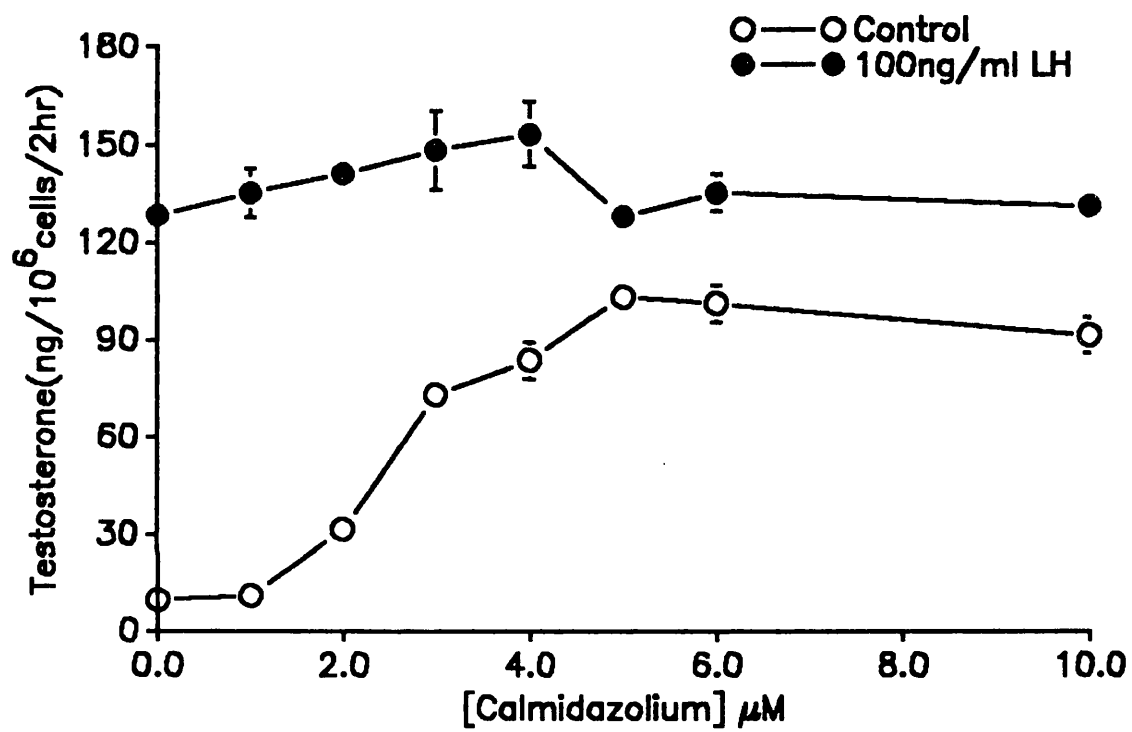
Experiments were carried out to investigate the effect of calmidazolium on steroidogenesis in rat Leydig cells, with the aim of continuing previous work on the role of calmodulin in steroidogenesis. Previous work (Sullivan & Cooke, 1985) showed that LH-stimulated testosterone production was inhibited by calmidazolium with an  $ED_{50}$  of approximately 30nM. However, the present investigations were unable to show an inhibition of steroid production at this concentration. At a higher concentration of calmidazolium ( $1\mu\text{M}$ ) a small stimulation of basal testosterone production was observed.

Therefore the effect of higher doses of calmidazolium on testosterone production were investigated. It was found that calmidazolium caused a dose-dependent stimulation of testosterone production, which reached a maximum with approximately  $4\mu\text{M}$  to  $10\mu\text{M}$  and then declined to basal levels with  $20\mu\text{M}$  or higher. The stimulation of testosterone production by calmidazolium was a consistent observation over a series of more than ten experiments. Therefore, the experiments that follow have concentrated on investigating the stimulatory action of calmidazolium on steroidogenesis.

Figure 4.5 show the stimulation of testosterone production by calmidazolium. This stimulation was not additive to LH-stimulated testosterone production. The effect of calmidazolium on pregnenolone and testosterone production was compared with that produced with LH (fig.4.6). Calmidazolium dose-dependently stimulated basal pregnenolone by approximately 13 fold. The same concentrations of calmidazolium, stimulated basal testosterone by approximately 10 fold. LH stimulation gave the expected dose-dependent increase in pregnenolone and testosterone production (fig.4.6b). Pregnenolone and testosterone production were increased by approximately 20 fold and

**Fig. 4.5 Effect of calmidazolium on basal and LH-stimulated testosterone production.** Leydig cells ( $2 \times 10^4$  cells/ well/  $200\mu\text{l}$ ) were incubated for 2 hours in the absence and presence of increasing concentrations of calmidazolium, and with and without LH (100ng/ml). The testosterone produced was measured as described in the Methods. Each point represents the mean  $\pm$  S.E. for triplicate incubations within one of three similar experiments.

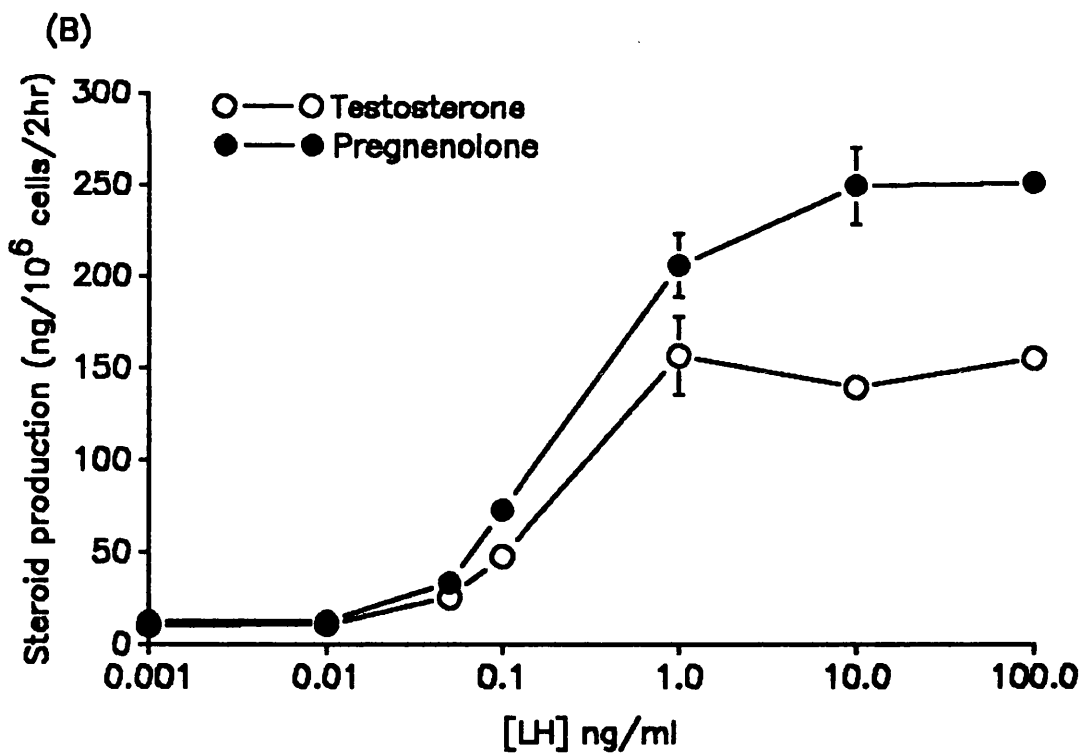
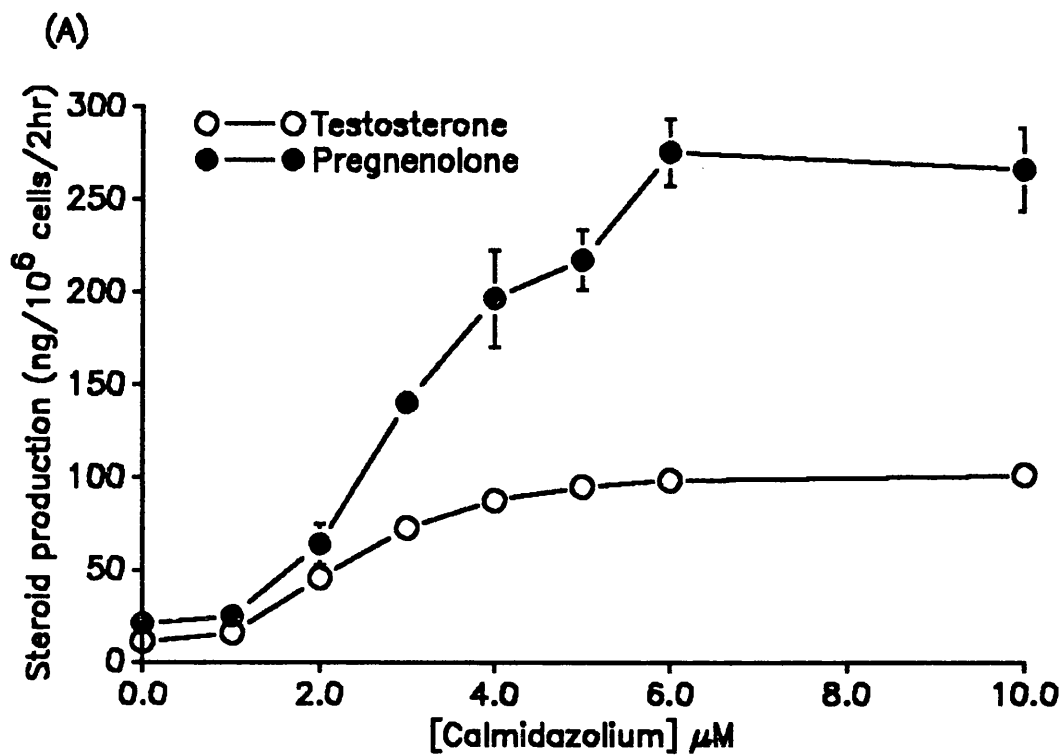
Figure 4.5



**Fig. 4.6 Comparison between calmidazolium and LH-stimulated pregnenolone and testosterone production.** Leydig cells ( $2 \times 10^4$  cells/ well/  $200\mu\text{l}$ ) were incubated for 2 hours (A) in the absence and presence of increasing concentrations of calmidazolium, and (B) with increasing concentrations LH. The pregnenolone and testosterone produced were measured as described in the Methods. Each point represents the mean  $\pm$  S.E. for triplicate incubations within one of three similar experiments.



Figure 4.6



15 fold respectively.

These results show that the capacity of calmidazolium to stimulate steroidogenesis is similar to that of LH. This effect of calmidazolium was found not to be exclusive to rat Leydig cells because this compound was also found to be a potent stimulator of steroidogenesis in mouse Leydig cells and rat adrenocortical cells (tables 4.1 and 4.2); in both these cell types a 10 fold increase in steroidogenesis was obtained.

The time-course of testosterone stimulation by LH, dbcAMP and calmidazolium were found to be very similar (fig.4.7). Calmidazolium stimulation exhibited the same initial lag phase (approx. 15 mins.) as seen with LH and dbcAMP stimulated testosterone production. Similarly, after 30 mins. there was a common linear increase in testosterone over the remaining 90 mins. of the 2hr incubation.

The effect on steroidogenesis caused by the removal of extracellular calcium and the addition of  $\text{La}^{3+}$  to the incubation medium was investigated.  $\text{La}^{3+}$  was added because it has been reported to inhibit entry of extracellular  $\text{Ca}^{2+}$  into cells (Weiss, 1974) and would therefore be expected to have similar effects to the removal of  $\text{Ca}^{2+}$ . As shown in chapter 3 the exclusion of  $\text{Ca}^{2+}$  from the incubation medium caused a 50% decrease in LH (100ng/ml)- and dbcAMP (1mM)- stimulated testosterone production (fig.4.8). In contrast, the exclusion of  $\text{Ca}^{2+}$  increased the effect of calmidazolium ( $4\mu\text{M}$ ) on testosterone production from  $79.7 \pm 5.4$  to  $110.3 \pm 8.7$  ng/ $10^6$  cells/2hr. Similar differences between LH and calmidazolium were also found when lanthanum chloride was added to the incubation medium (fig.4.9). As demonstrated in chapter 3 the LH-stimulated testosterone production was inhibited by  $\text{La}^{3+}$ ; inhibition was greater at a lower concentration of LH (0.5ng/ml) compared with a higher concentration of LH (50ng/ml) (fig.4.9a).

Calmidazolium ( $\mu\text{M}$ )	Testosterone production (ng/ $10^6$ cells/2hr)
0	24.5 $\pm$ 2.7
2.5	25.1 $\pm$ 2.9
5.0	86.2 $\pm$ 4.1
10.0	239.1 $\pm$ 22.5

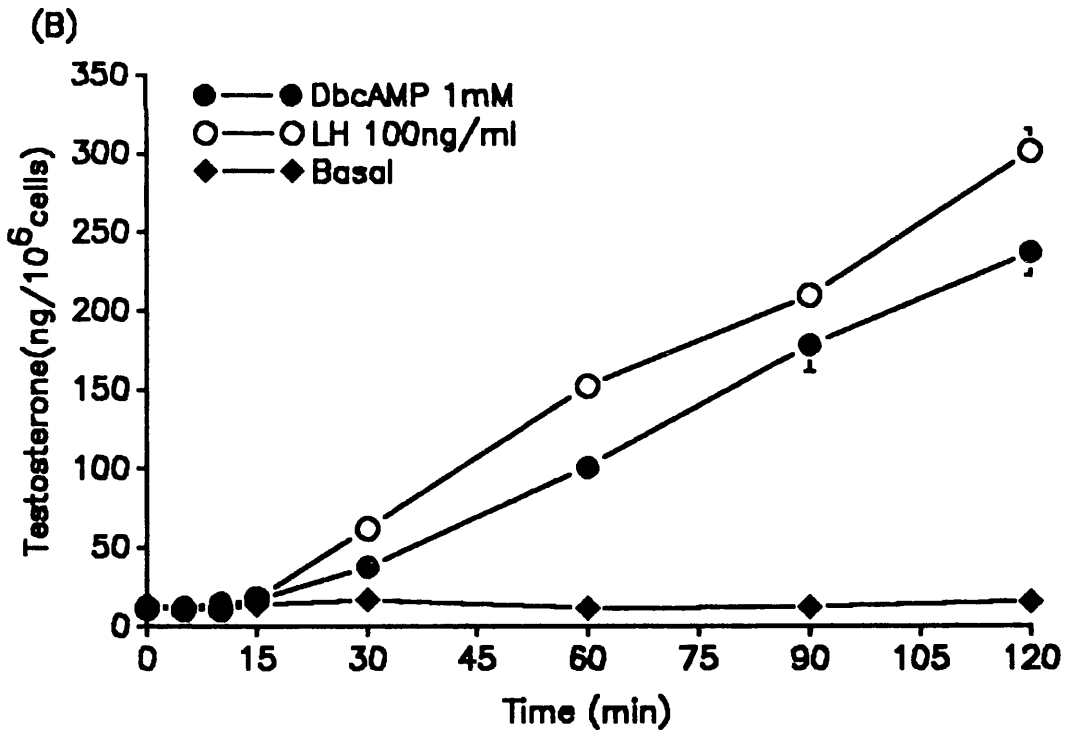
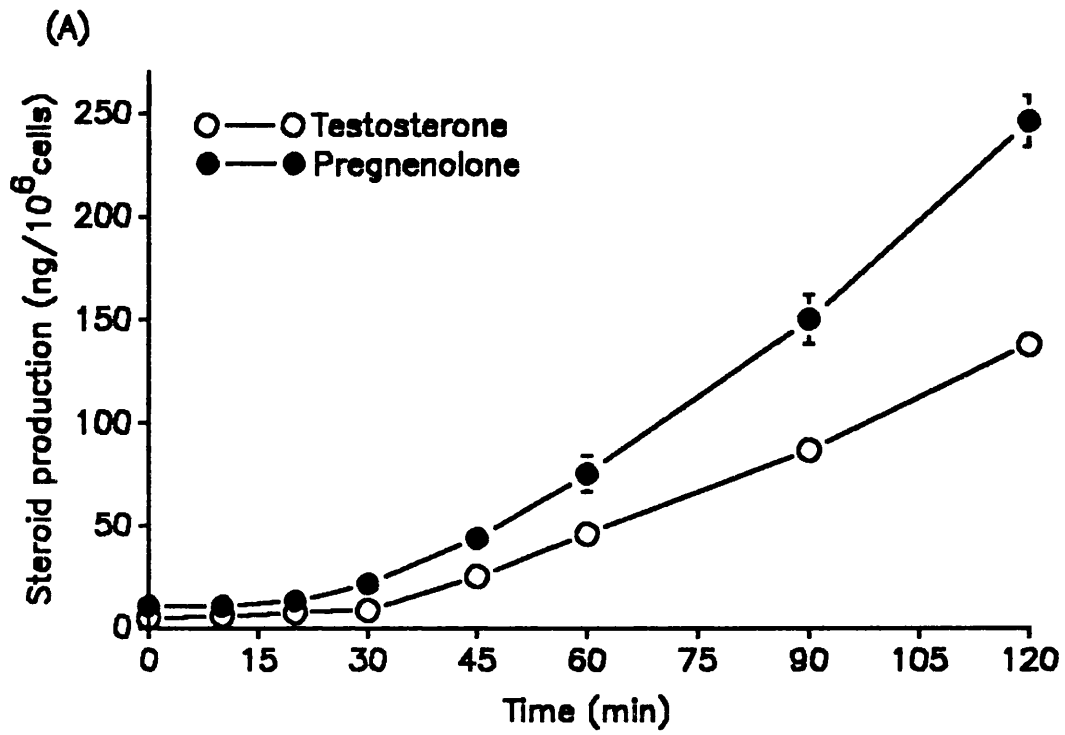
**Table 4.1** The stimulation of testosterone production in mouse Leydig cells by calmidazolium. Incubations and assays for testosterone production were carried out according to Materials and Methods. The values for testosterone production are the mean  $\pm$  SE for triplicate incubations.

Calmidazolium ( $\mu\text{M}$ )	Pregnenolone production (ng/ $10^6$ cells/2hr)
0	34.1 $\pm$ 4.4
2.0	42.2 $\pm$ 3.3
4.0	91.8 $\pm$ 11.8
6.0	210.7 $\pm$ 10.0
10.0	340.9 $\pm$ 21.5

**Table 4.2** The stimulation of pregnenolone production in rat adrenocortical cells by calmidazolium. Incubations and pregnenolone production were carried out according to the Materials and Methods. The values for pregnenolone production are the mean  $\pm$  SE for triplicate incubations.

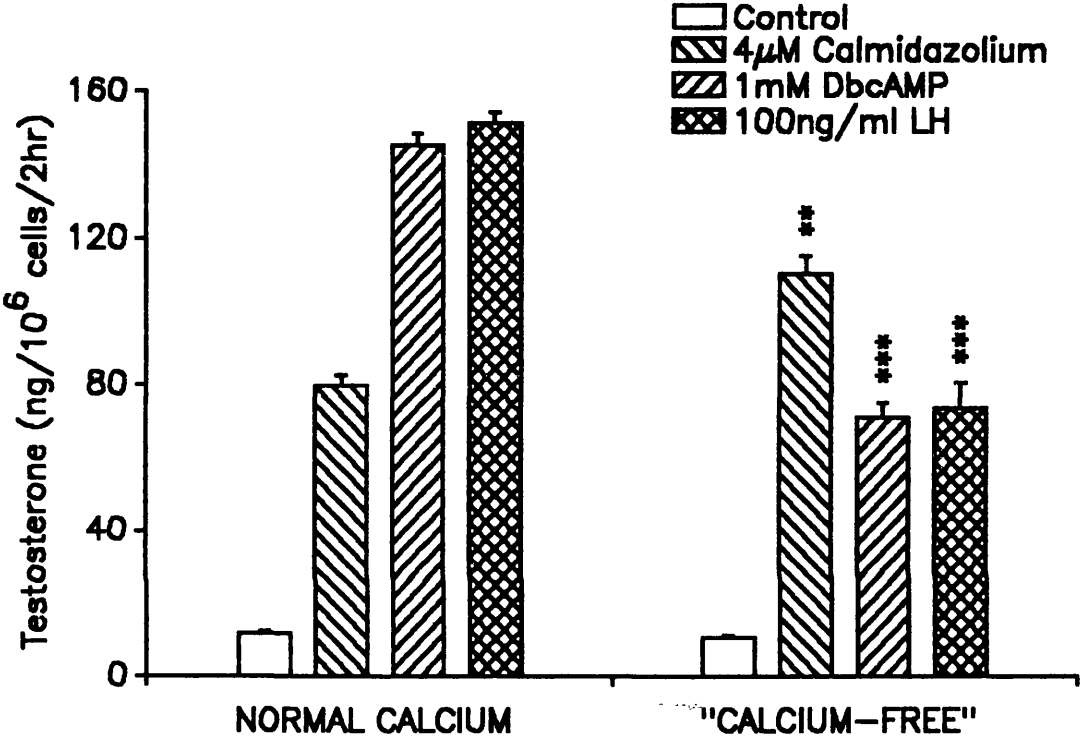
**Fig. 4.7 Time course of pregnenolone and testosterone production.** Leydig cells ( $2 \times 10^4$  cells/ well/  $200\mu\text{l}$ ) were incubated for different times with (A) calmidazolium ( $4\mu\text{M}$ ), and (B) with LH ( $100\text{ng/ml}$ ) and dibutyryl cAMP ( $1\text{mM}$ ). The pregnenolone and testosterone produced were measured as described in the Methods. Each point represents the mean  $\pm$  S.E. for triplicate incubations within one of two similar experiments.

Figure 4.7



**Fig. 4.8 Effect of removing extracellular calcium on calmidazolium-stimulated testosterone production.** Leydig cells ( $2 \times 10^4$  cells/ well/  $200\mu\text{l}$ ) were incubated for 2 hours with calmidazolium ( $4\mu\text{M}$ ), LH ( $100\text{ng/ml}$ ) and dibutyryl cAMP ( $1\text{mM}$ ), in the presence and absence of extracellular calcium. The testosterone produced was measured as described in the Methods. Each point represents the mean  $\pm$  S.E. for triplicate incubations within one of three similar experiments. (\*\*  $P < 0.01$ ; \*\*\*  $P < 0.001$ , similar to normal calcium medium)

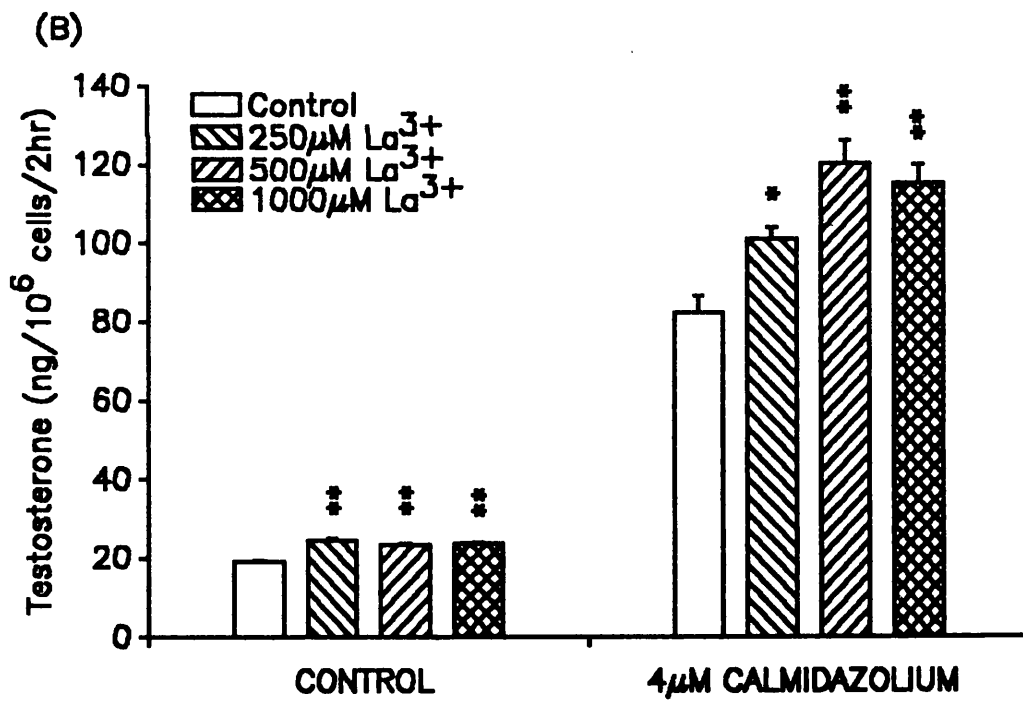
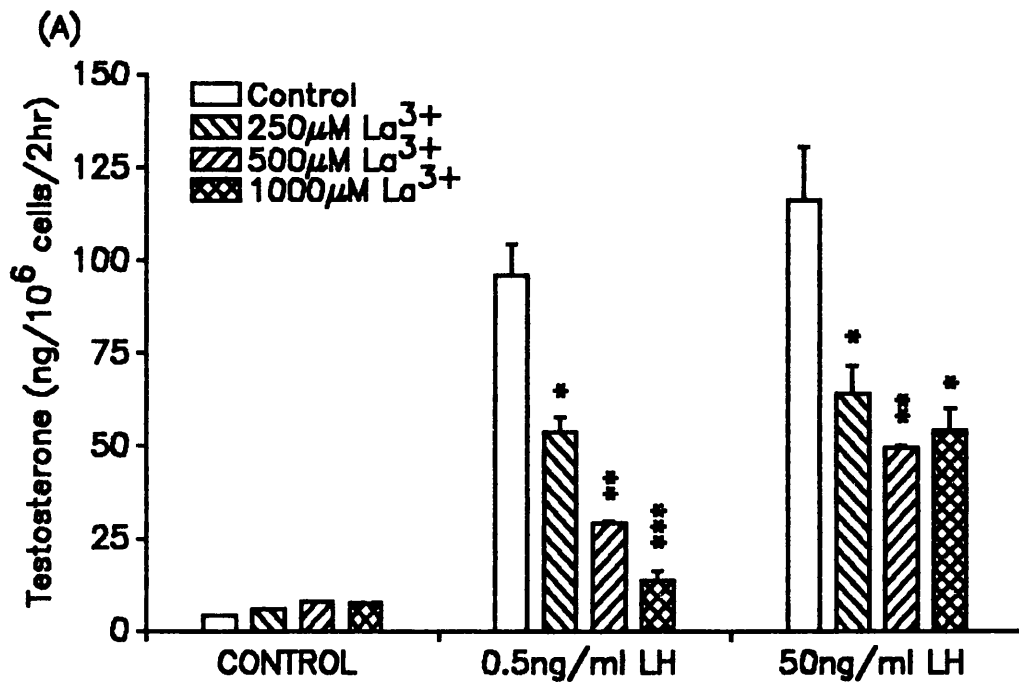
Figure 4.8



**Fig. 4.9 Comparison between the effect of La<sup>3+</sup> ions on calmidazolium- and LH-stimulated testosterone production.** Leydig cells (2 x 10<sup>4</sup> cells/ well/ 200μl) were incubated for 2 hours with (A) LH (0.5ng/ml; 50ng/ml) and (B) calmidazolium (4μM) in the presence of different concentrations of lanthanum chloride. The testosterone produced was measured as described in the Methods. Each point represents the mean ± S.E. for triplicate incubations within one of two similar experiments. (\* P < 0.05; \*\* P < 0.01; \*\*\* P < 0.001, similar to control)



Figure 4.9



In contrast, testosterone stimulated by calmidazolium was increased by the addition of  $\text{La}^{3+}$  - this was similar to that observed when extracellular  $\text{Ca}^{2+}$  was removed (fig.4.9b).

TMB-8, an inhibitor of intracellular calcium mobilization, has been shown to inhibit steroidogenesis stimulated with LH and dibutyryl cyclic AMP (see chapter 3). This is in contrast to testosterone production stimulated by calmidazolium (fig.4.10), which was unaffected by TMB-8 even at the highest concentration of  $100\mu\text{M}$ .

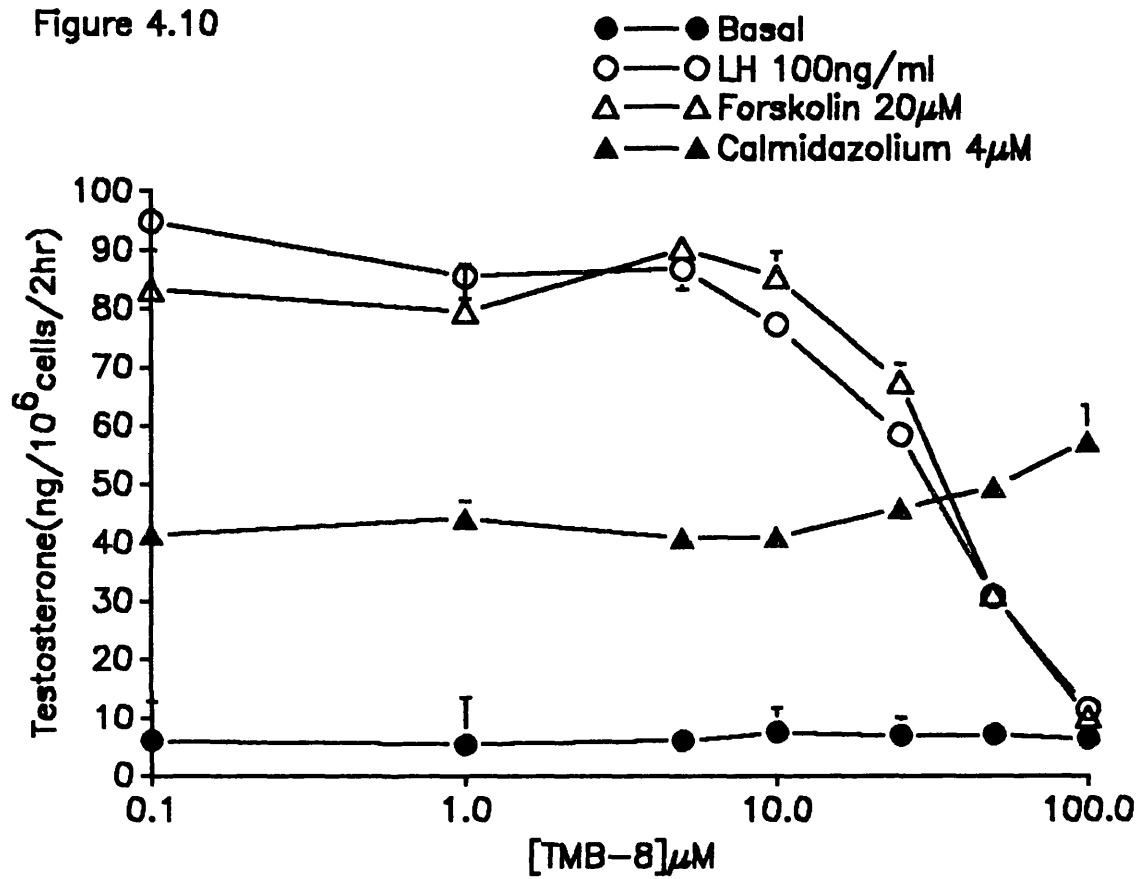
A characteristic of LH- and dbcAMP- stimulated steroidogenesis is the requirement for continuous protein synthesis. We used cycloheximide, a translation inhibitor, to determine if the stimulatory action of calmidazolium required protein synthesis (fig.4.11). The testosterone production stimulated with  $1\text{ng/ml}$  LH,  $100\text{ ng/ml}$  LH and  $1\text{mM}$  8-Bromo-CAMP (fig.4.11a) was inhibited by 80% with  $0.01\text{mM}$  cycloheximide. At higher concentrations of cycloheximide ( $0.05$  and  $0.1\text{mM}$ ), testosterone production was decreased almost to basal levels. In contrast, the stimulation of testosterone with  $2\mu\text{M}$ ,  $4\mu\text{M}$  and  $5\mu\text{M}$  calmidazolium was unaffected by the concentrations of cycloheximide used (fig.4.11b).

In spite of these differences between LH- and calmidazolium- stimulated testosterone production, it was found that there was no additive effects when LH ( $100\text{ng/ml}$ ) and calmidazolium were added together. This implies that these two compounds have common site(s) of action to increase steroidogenesis.

It has been shown that  $22(\text{R})\text{OH}$ -Cholesterol supported testosterone production is inhibited by calmidazolium (Sullivan and Cooke, 1985). This was investigated in the present study in order to assess the dose-dependent effect of calmidazolium on  $22(\text{R})\text{OH}$ -Cholesterol supported testosterone production (fig.4.12). The  $\text{ID}_{50}$  doses of calmidazolium were  $15\mu\text{M}$ ,  $10\mu\text{M}$  and  $5\mu\text{M}$  for  $0.1\mu\text{M}$ ,  $0.5\mu\text{M}$  and  $1\mu\text{M}$  of  $22(\text{R})\text{OH}$ -

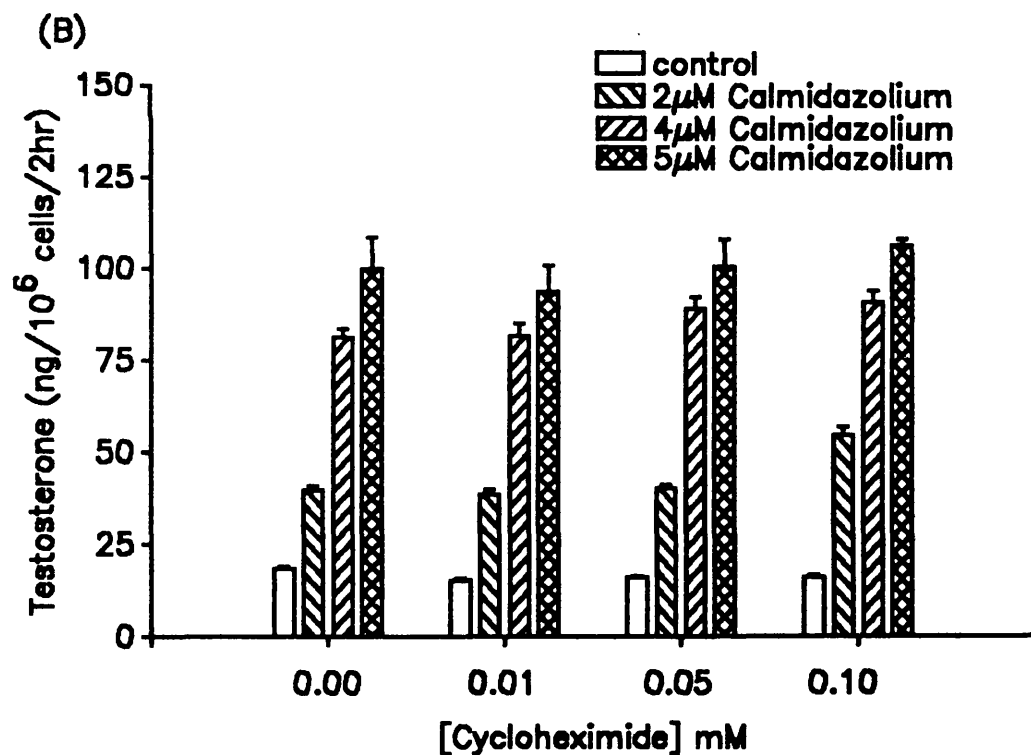
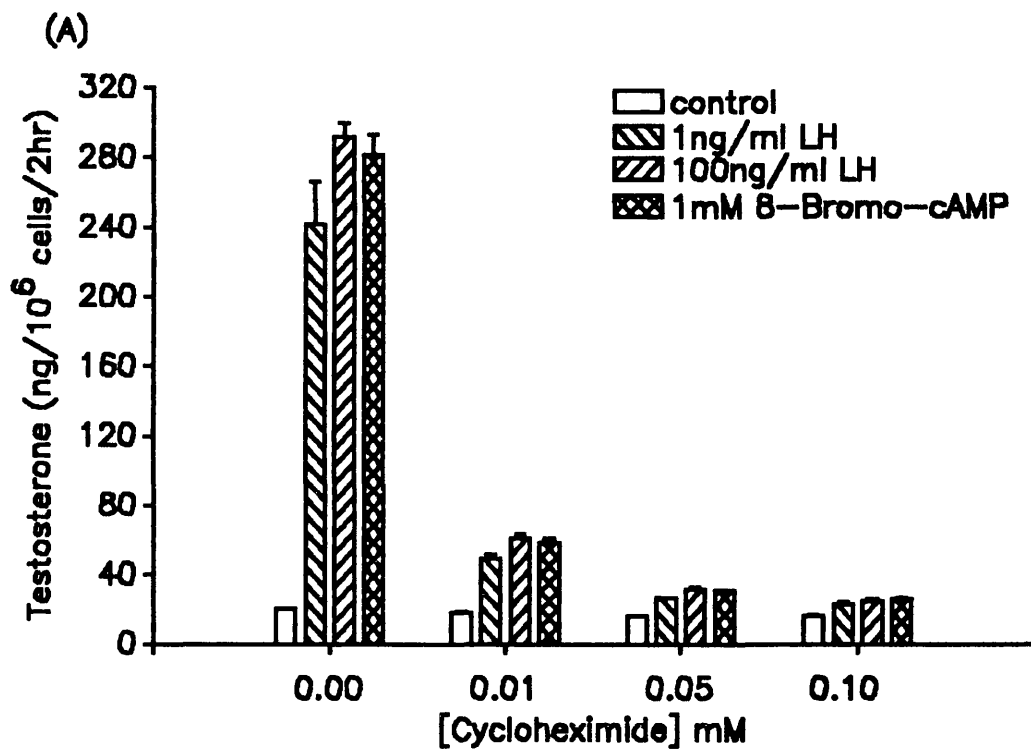
**Fig. 4.10 Comparison between the effect of TMB-8, an inhibitor of intracellular calcium release, on basal, calmidazolium-, forskolin- and LH-stimulated testosterone production.** Leydig cells ( $2 \times 10^4$  cells/ well/  $200\mu\text{l}$ ) were incubated for 2 hours with LH ( $100\text{ng/ml}$ ), forskolin ( $20\mu\text{M}$ ) and calmidazolium ( $4\mu\text{M}$ ) in the presence of increasing concentrations of TMB-8. The testosterone produced was measured as described in the Methods. Each point represents the mean  $\pm$  S.E. for triplicate incubations within one of two similar experiments.

Figure 4.10



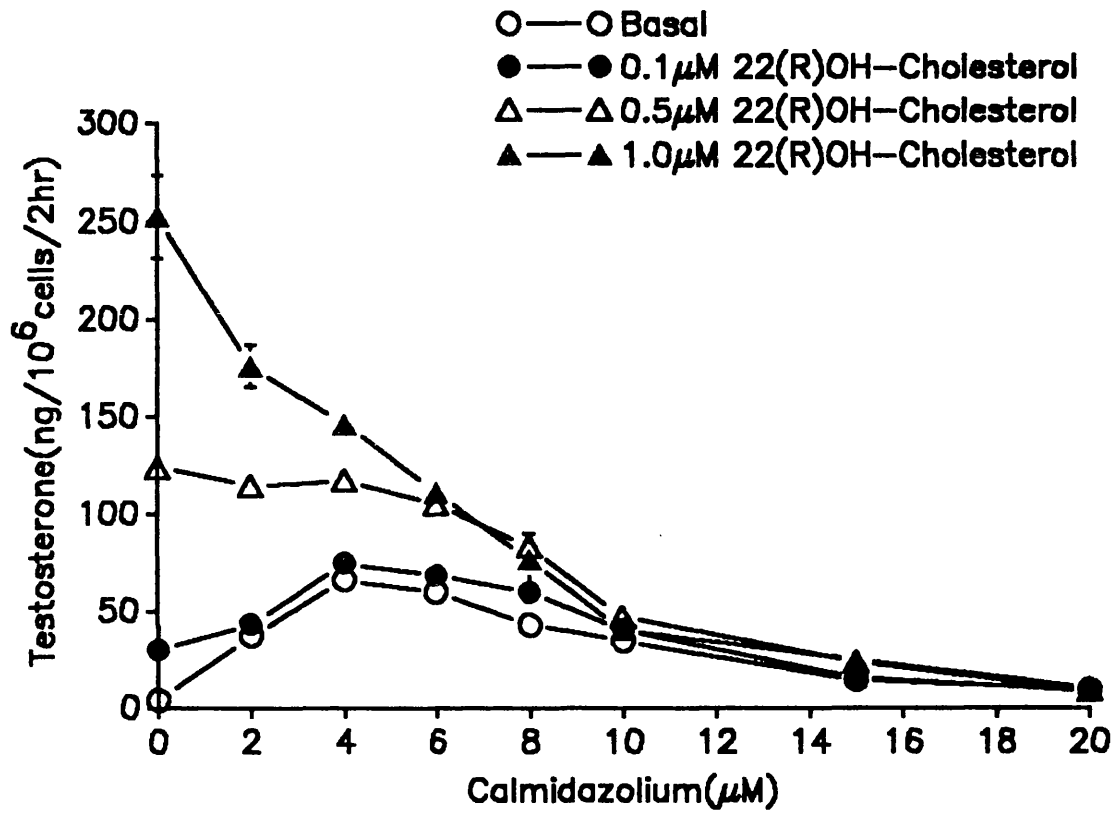
**Fig. 4.11** The effect of cycloheximide, an inhibitor of proteins synthesis, on calmidazolium-stimulated testosterone production. Leydig cells ( $2 \times 10^4$  cells/ well/  $200\mu\text{l}$ ) were incubated for 2 hours with (A) LH (1ng/ml and 100ng/ml), 8-bromo-cAMP (1mM), and (B) calmidazolium (2, 4 and  $5\mu\text{M}$ ), in the absence and presence of increasing concentrations of cycloheximide. The testosterone produced were measured as described in the Methods. Each point represents the mean  $\pm$  S.E. for triplicate incubations within one of two similar experiments.

Figure 4.11



**Fig. 4.12** The effect of calmidazolium on the conversion of 22(R)OH-cholesterol to testosterone. Leydig cells ( $2 \times 10^4$  cells/ well/  $200\mu\text{l}$ ) were incubated for 2 hours with 22(R)OH-cholesterol (0.1, 0.5 and  $1\mu\text{M}$ ) in the absence and presence of increasing concentrations of calmidazolium. The testosterone produced were measured as described in the Methods. Each point represents the mean  $\pm$  S.E. for triplicate incubations within one of two similar experiments.

Figure 4.12





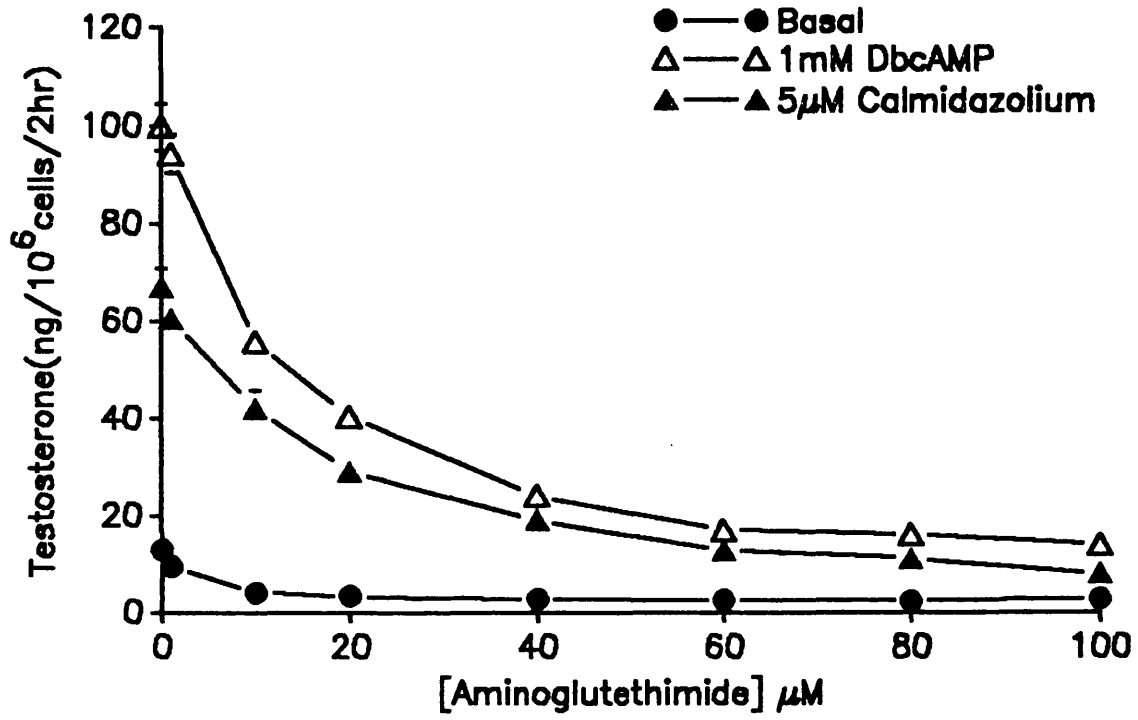
Cholesterol supported testosterone production, respectively. There was no additive stimulation of testosterone production between 22(R)OH-Cholesterol and calmidazolium. The profiles of testosterone production appears to be the net result of the stimulatory and inhibitory activities of calmidazolium, superimposed onto the stimulatory action of 22(R)OH-Cholesterol.

The conversion of cholesterol to pregnenolone can be prevented by inhibitors of the cholesterol side chain cleavage enzyme (CSCC). Figure 4.13. shows the effect of a commonly used CSCC inhibitor, aminoglutethimide, on testosterone production. Both dbcAMP (1mM)- and calmidazolium (5 $\mu$ M)-stimulated testosterone production were inhibited by aminoglutethimide with an ED<sub>50</sub> of approximately 15 $\mu$ M.

In order to investigate further if the observed effects of calmidazolium were via inhibition of calmodulin, another inhibitor, trifluoperazine, was investigated. However, in agreement with previous findings (Hall et al.,1981; Sullivan and Cooke, 1985) no stimulatory effect was found (fig.4.14).

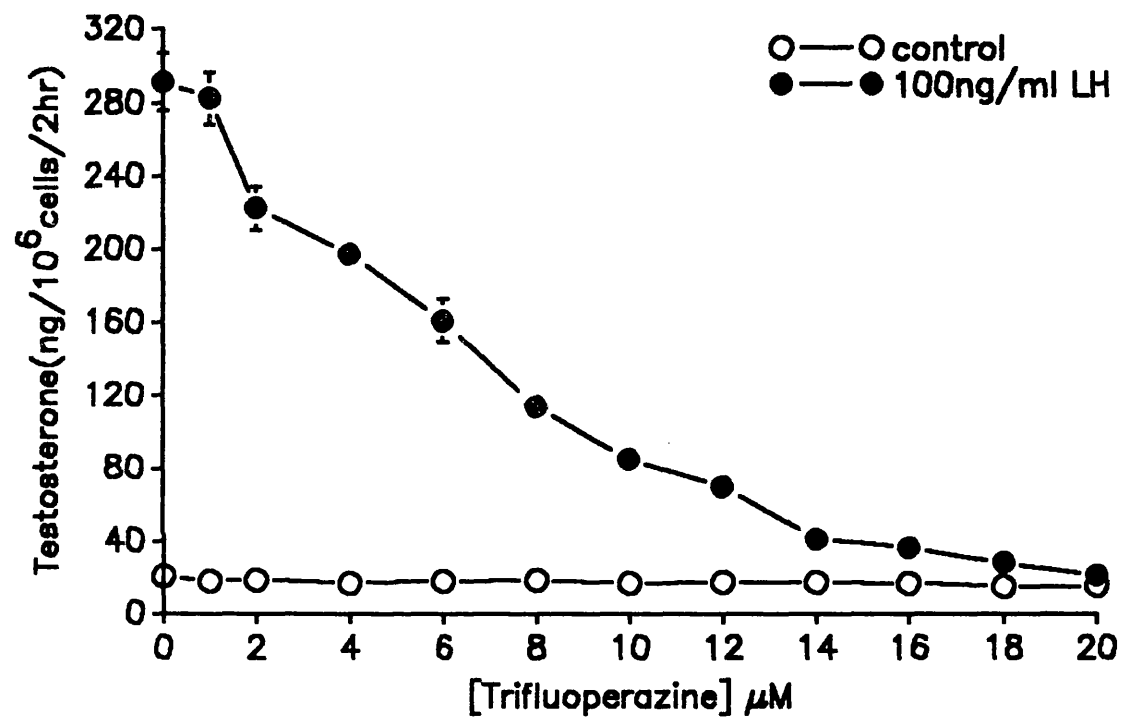
**Fig. 4.13** The effect of aminoglutethimide, an inhibitor of cholesterol side-chain cleavage, on calmidazolium- and dibutyryl cAMP- stimulated testosterone production. Leydig cells ( $2 \times 10^4$  cells/ well/  $200\mu\text{l}$ ) were incubated for 2 hours with dibutyryl cAMP (1mM) and calmidazolium ( $5\mu\text{M}$ ) in the absence and presence of increasing concentrations of aminoglutethimide. The testosterone produced were measured as described in the Methods. Each point represents the mean  $\pm$  S.E. for triplicate incubations within one of two similar experiments.

Figure 4.13



**Fig. 4.14 The effect of trifluoperazine, an inhibitor of calmodulin, on LH-stimulated testosterone production.** Leydig cells ( $2 \times 10^4$  cells/ well/  $200\mu\text{l}$ ) were incubated for 2 hours with LH (100ng/ml) in the absence and presence of increasing concentrations of trifluoperazine. The testosterone produced were measured as described in the Methods. Each point represents the mean  $\pm$  S.E. for triplicate incubations within one of two similar experiments.

Figure 4.14



### **4.3 DISCUSSION**

This study has investigated the action of calmidazolium on steroidogenesis and cyclic AMP production. The synthesis of cyclic AMP stimulated by LH, cholera toxin and forskolin, were inhibited by calmidazolium. Calmidazolium exhibits both stimulatory and inhibitory effects on steroidogenesis, and these effects were dependent on the concentration of the compound used. In previously published results (Sullivan & Cooke, 1985), inhibition was obtained with nanomolar concentrations of calmidazolium. However, in the present study the inhibition of testosterone production was obtained with concentrations of calmidazolium  $>10^{-5}$  M. This micromolar concentration of calmidazolium is similar to that used for the inhibition of steroidogenesis in adrenal and granulosa cells (Tsang & Carnegie, 1983; Papadopoulos et al. 1990). The inhibitory effects on LH-stimulated steroidogenesis support the conclusions of other workers (Hall et al. 1981; Tsang & Carnegie, 1983; Sullivan & Cooke, 1985), i.e. that steroidogenesis is a calmodulin-dependent process. However, there have not been any previous reports showing a stimulatory effect of calmidazolium on steroid production.

The synthesis of cyclic AMP in adrenal cells, ovarian cells, testicular Leydig cells and thymocytes, have been shown to be inhibited by calmodulin antagonists (Hall et al., 1981; Wilson et al., 1984; Segal, 1989; Papadopoulos et al., 1990). The present study, show that the basal cyclic AMP production was inhibited by calmidazolium and by the removal of extracellular  $Ca^{2+}$ , suggesting the site of  $Ca^{2+}$ -calmodulin requirement to be post receptor binding. This is in agreement with earlier studies, which showed that  $Ca^{2+}$  was not required for the binding of HCG to the LH-receptor (Mendelson et al., 1975). The results obtained using cholera toxin and forskolin to stimulate cyclic AMP

production, also give further support to this suggestion. Although these results suggest the site of action of calmidazolium and  $\text{Ca}^{2+}$ -sensitivity to be the catalytic sub-unit of the adenylate cyclase enzyme, no firm conclusion can be drawn until studies on isolated plasma membranes are performed. It has recently been reported that forskolin stimulation in whole cells and in isolated plasma membranes may not be through the same mechanisms (Papadopoulos et al., 1990). These workers showed that in whole Y-1 adrenal tumour cells, both ACTH and forskolin stimulated cyclic AMP production were inhibited by trifluoperazine. However, in Y-1 plasma membranes it was found that trifluoperazine and other calmodulin antagonists showed no inhibition of forskolin-stimulated cyclic AMP production.

From the results obtained using the removal of extracellular  $\text{Ca}^{2+}$ , and the addition of  $\text{La}^{3+}$  and the studies with calmodulin antagonists, it can be concluded that cyclic AMP synthesis in rat Leydig cells is likely to be dependent on  $\text{Ca}^{2+}$ -calmodulin. The precise site(s) of this requirement requires studies on isolated plasma membranes.

Previous studies have shown that the omission of calcium from rat Leydig cell incubations resulted in marked decreases in testosterone production, but did not inhibit the LH-stimulated cyclic AMP-dependent protein kinase activity (Janszen et al., 1976). In support of this, the present study also shows that the exclusion of calcium inhibited both the LH- and dibutyryl cyclic AMP- stimulated testosterone production. This requirement for extracellular calcium is further illustrated by the inhibition of testosterone production using lanthanum. Lanthanum inhibits the influx of calcium into cells, and has been shown to inhibit both cyclic AMP and steroid production in adrenocortical cells and granulosa cells (Tsang and Carnegie, 1983; Haksar et al., 1976). In contrast, testosterone production stimulated by calmidazolium was not inhibited by the removal of

extracellular calcium, or by the addition of lanthanum to the incubation medium. This argues against a role for calcium in the stimulatory action of calmidazolium. In fact, there was a significant enhancement of steroid production with the removal of extracellular calcium, or the addition of lanthanum; the reason for this is not known. In support of these observations, TMB-8, the putative antagonist of intracellular  $\text{Ca}^{2+}$  mobilization, also had no effect on testosterone production stimulated by calmidazolium.

In steroidogenic cells the rate-limiting step for steroid production is the transport of cholesterol to the inner mitochondrial membrane, for the conversion of cholesterol to pregnenolone. This conversion is catalyzed by the cytochrome P-450 cholesterol-side-chain-cleavage (CSCC) enzyme system, located in the inner mitochondrial membrane (Simpson, 1979). It is generally agreed that the acute regulation of steroidogenesis by the trophic hormones is localized in the mitochondria, but the precise mechanism of regulation is not known. It has been established for a long time that the stimulation of steroidogenesis by trophic hormones is acutely sensitive to the protein synthesis inhibitor, cycloheximide (Moyle et al., 1971; Cooke et al., 1975). Furthermore, it has also been shown that the transfer of cholesterol to the inner mitochondrial membrane can be inhibited by cycloheximide (Privalle et al., 1983). These observations suggested that trophic hormones stimulate the synthesis of protein(s) which allow the transfer of cholesterol to the inner mitochondrial membrane for side-chain-cleavage. The inhibition of LH- and 8-bromo cyclic AMP-stimulated testosterone production by cycloheximide, is in agreement with previous findings (Cooke et al., 1975). The insensitivity of calmidazolium-stimulated steroidogenesis to cycloheximide, suggest that the mechanisms of stimulation are different. However, the time-courses for calmidazolium, LH- and dibutyryl cyclic AMP- stimulated testosterone production showed the same profiles. This



may indicate common mechanisms for the stimulation of steroid production. In support of this, the addition of LH (100ng/ml) together with stimulatory concentrations of calmidazolium, did not give a stimulation of steroidogenesis above that obtained with LH alone. It would appear that calmidazolium is capable of replacing the role played by the short half-life protein(s) in the stimulation of mitochondrial pregnenolone production. This is reflected by the capacity of calmidazolium to stimulate pregnenolone production, which was shown to be equivalent to that of LH-stimulated production. The ability of calmidazolium to stimulate the production of pregnenolone is also shown by the sensitivity to inhibition with aminoglutethimide, a compound which is known to inhibit cholesterol side-chain cleavage.

The sensitivity of 22(R)OH-cholesterol supported testosterone production to inhibition by calmidazolium agrees with previous findings (Sullivan and Cooke, 1985). This implies that the activity of the cytochrome P-450 CSCC enzyme is inhibited by calmidazolium. However, calmidazolium could be inhibiting at sites that are post-mitochondrial. The measurement of 22(R)OH-cholesterol supported pregnenolone production in the presence of calmidazolium would clarify the possible sites of inhibition.

The outer membrane of mitochondria from steroidogenic tissues, contain large numbers of peripheral-type benzodiazepine receptors (PBR) (De Souza et al., 1985; Snyder et al., 1987). These receptors, have been directly linked with the stimulation of steroid production. Specific ligands have been developed, that will bind to PBRs and stimulate pregnenolone production in isolated mitochondria (Papadopoulos et al., 1990). Like calmidazolium, the stimulation of steroidogenesis by these ligands was not inhibited by cycloheximide, but unlike calmidazolium, the degree of stimulation obtained was relatively poor. It is possible that calmidazolium may possess better agonistic properties,

when compared with the known ligands. This possible action of calmidazolium requires further investigation.

No stimulatory effect on steroidogenesis was found with another calmodulin inhibitor, trifluoperazine. However, it has recently been demonstrated (although not discussed in that paper) that low concentrations of trifluoperazine increased HCG (human Chorionic Gonadotrophin)-, and cyclic AMP- stimulated progesterone production in mouse Leydig tumour cells (MA-10), and also by itself increased de novo cholesterol synthesis (Nagy and Freeman, 1990). These findings suggests that the use of calmidazolium and trifluoperazine to infer calmodulin involvement, in the positive regulation of steroidogenesis, should be made with caution.

Calmidazolium is chemically related to the imidazole fungicides isoconazole, miconazole and econazole. These compounds have been shown to inhibit testosterone production in Leydig cells. The inhibition was shown to occur over equivalent concentrations at which calmidazolium stimulated testosterone production, and no stimulation was reported (Schürmeyer & Nieschlag, 1984). Therefore, it would appear that the stimulation of steroidogenesis is not a common property of these compounds.

It is concluded from the present study that calmidazolium is a potent stimulator of steroidogenesis, but by-passes the requirement for cyclic AMP, calcium and protein synthesis. Calmidazolium is therefore a potentially important compound for use in the further elucidation of the mechanisms that regulate steroidogenesis.

## **CHAPTER FIVE**

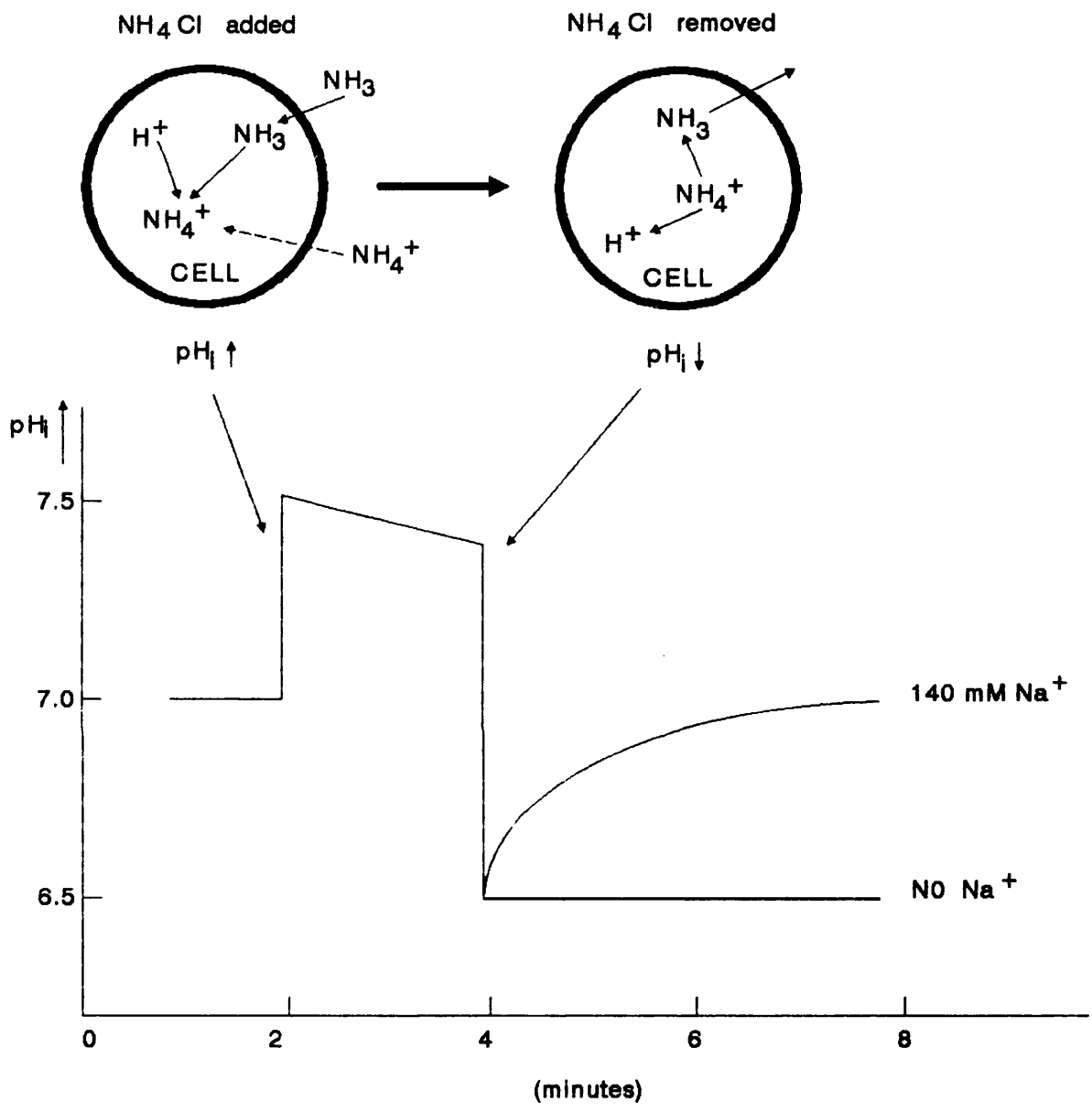
### **Role of Intracellular pH in Testosterone Production**

## 5.1 INTRODUCTION

The regulation of intracellular pH is important for the basic house-keeping of all cells. This is because essential enzymatic processes and the control of the cell-cycle is dependent on intracellular pH (Madhus, 1988). Mammalian cells in general have two basic mechanisms for the regulation of intracellular pH, these include bicarbonate exchangers and the  $\text{Na}^+/\text{H}^+$  exchanger. The  $\text{Na}^+/\text{H}^+$  exchanger can be specifically inhibited by amiloride and related compounds.

To study pH regulation the cytosol may be acidified using the ammonium prepulse technique (Boron and De Weer, 1976). This involves the addition and the subsequent removal of  $\text{NH}_4\text{Cl}$  from the incubation medium (Fig. 5.1). The addition of  $\text{NH}_4\text{Cl}$  produces an immediate rise in the intracellular pH ( $\text{pH}_i$ ) due to the entry of  $\text{NH}_3$  into the cells, which results in a decrease in the cytosolic proton concentration and a concomitant increase in the concentration of  $\text{OH}^-$  as  $\text{NH}_3$  combines with  $\text{H}^+$  to give  $\text{NH}_4^+$ . This is followed by a slow decay of the  $\text{pH}_i$  due to entry of  $\text{NH}_4^+$ . Upon the removal of  $\text{NH}_4\text{Cl}$  from the incubation medium, there is an immediate fall in the  $\text{pH}_i$ , caused by the diffusion of  $\text{NH}_3$  from the cells, which result in a sudden rise in the intracellular concentration of  $\text{H}^+$  ions ( $[\text{H}^+]_i$ ). The mechanisms that regulate  $\text{pH}_i$  back to the normal value can be studied under different conditions, while the pH is continuously monitored.

The continuous measurement of  $\text{pH}_i$  can be achieved by the use of the fluorescent pH-probe, BCECF (2'7'bis-carboxyethyl-5'(6')carboxyfluorescein). This water soluble probe is introduced into cells in the same way as fura-2, i.e. via its acetoxymethyl ester (BCECF/AM). The fluorescent intensity of BCECF increases linearly from pH6.5 - pH8.0 and makes the calibration of intracellular pH very straight forward (Tolkovsky and Richards, 1987).



**Fig. 5.1 The ammonium prepulse technique for the study of intracellular pH**

In this study the mechanisms for the regulation of  $pH_i$  in rat Leydig cells were investigated in BCECF loaded cells plated on poly-lysine coated coverslips. Use was made of the superfusion system developed for the measurement of intracellular calcium (see chapter 2 and 3). In addition, the possible pH-dependence of steroidogenesis in rat Leydig cells was investigated. To achieve this, various alterations were made to the incubation medium within the cuvette using superfusion. These changes included the addition of amiloride,  $NaHCO_3$  and  $NH_4Cl$  to the incubation medium.

## **5.2 RESULTS**

The cytosol was acidified by the ammonium prepulse technique by the addition and subsequent removal of 20mM  $NH_4Cl$  from the superfusing medium (Fig.5.2). The addition of  $NH_4Cl$  to the superfusion medium produced an immediate rise in the  $pH_i$ . This was followed by a slow decay of the  $pH_i$ . Upon the removal of  $NH_4Cl$  from the superfusion medium, there was an immediate fall in the  $pH_i$ . The cells were washed with a superfusion medium that was sodium-containing,  $Na^+$ -HBSS (Hank's buffered saline solution), the recovery from the acid-load was exponential. However, if the washing medium contained bicarbonate eg. 5mM  $NaHCO_3$  /  $Na^+$ -HBSS, the recovery from the acid-load was more rapid.

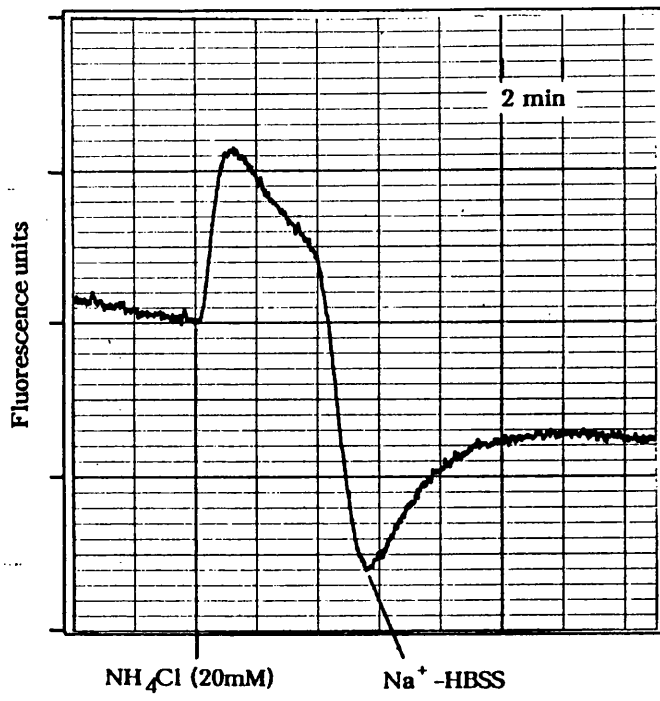
The above observation was supported by fig.5.3 which show the enhancement of recovery from an ammonium prepulse by the addition of 5mM  $NaHCO_3$  to the  $Na^+$ -HBSS superfusing medium. To confirm the presence of a  $Na^+/H^+$  antiporter in rat Leydig cells, the washing medium was changed from  $Na^+$ -HBSS to  $K^+$ -HBSS (high potassium

**Fig. 5.2 Demonstration of pH regulation by the ammonium prepulse technique.**

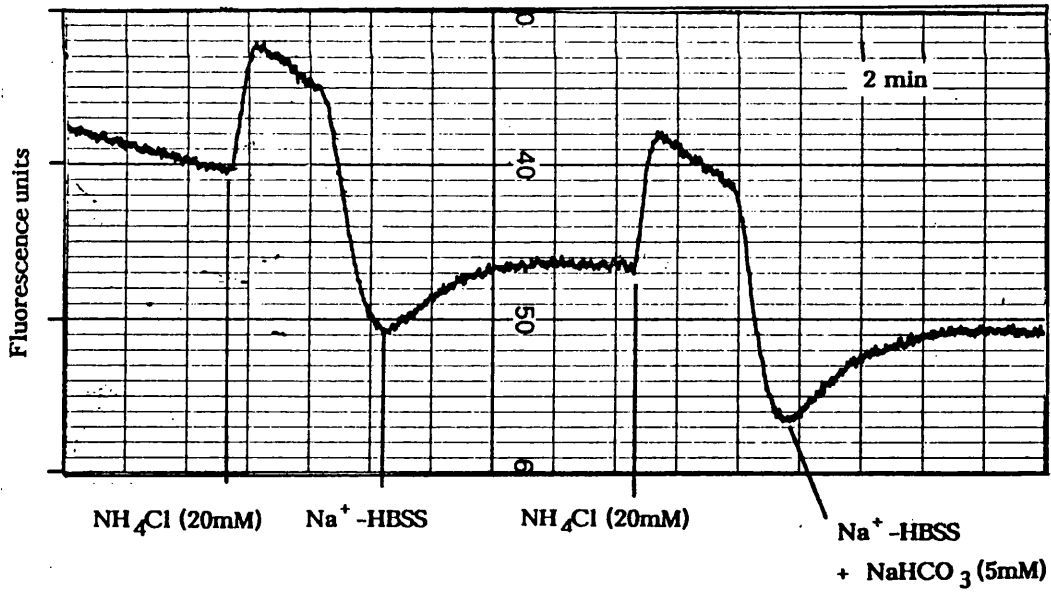
Leydig cells ( $3 \times 10^5$  cells/ coverslip) were loaded with BCECF/AM ( $4\mu\text{M}$ ) for 40mins and then washed twice in large volumes of  $\text{Na}^+$ -HBSS. The coverslip was placed diagonally in a square (3ml) cuvette and held in place between two split-Teflon rings. The bathing solution ( $34^\circ\text{C}$ ) was changed continuously by means of a peristaltic pump. All additions were made by changing the superfusion medium (HBSS) to one containing the required changes. Fluorescence was monitored at an emission of 525nm (slit width, 9nm) and excited at 495nm (slit width, 4.5nm).

Figure 5.2

(A)



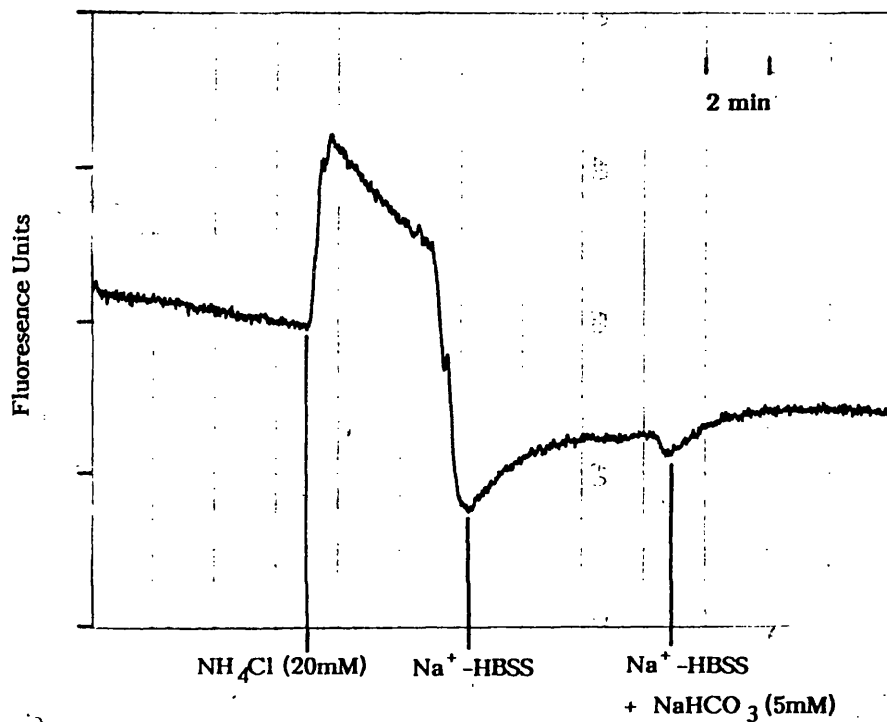
(B)





**Fig. 5.3** The influence of bicarbonate ions on pH recovery after a prepulse of ammonium. Leydig cells ( $3 \times 10^5$  cells/ coverslip) were incubated for 40mins with BCECF/AM ( $4\mu\text{M}$ ), then washed twice with large volumes of  $\text{Na}^+$ -HBSS. The coverslip was placed diagonally in a square (3ml) cuvette and held in place between two split-Teflon rings. The bathing solution ( $34^\circ\text{C}$ ) was changed continuously by means of a peristaltic pump. All additions were made by changing the superfusion medium (HBSS) to one containing the required changes. Fluorescence was monitored at an emission of 525nm (slit width, 9nm) and excited at 495nm (slit width, 4.5nm).

Figure 5.3



HBSS). With this superfusing medium, no recovery from acidification was observed. This inhibition of  $pH_i$  recovery was reversed by returning to  $Na^+$ -HBSS (fig.5.4).

The  $Na^+/H^+$  antiporter can be specifically inhibited by amiloride, which competitively inhibits the binding of  $Na^+$  to the extracellular site that accommodates  $Na^+$  ions (Haggerty et al., 1985). In fig.5.5 the cells were washed with high  $K^+$ -HBSS, and as seen in fig.5.4 there was no recovery from acidification. The addition of  $Na^+$ -HBSS containing  $200\mu M$  amiloride caused a further acidification. On washing with  $5mM$   $NaHCO_3$  /  $Na^+$ -HBSS to remove the amiloride, the cells recovered.

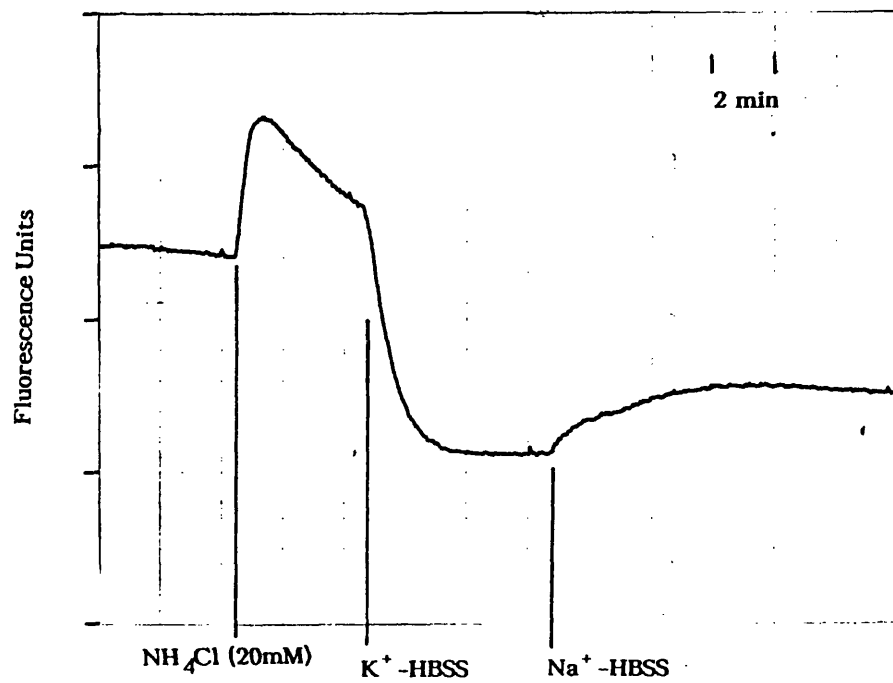
To assess the contribution of  $NaHCO_3$  to the recovery  $pH_i$  from an ammonium prepulse, the cells were washed with  $K^+$ -HBSS, and then washed with  $K^+$ -HBSS containing  $5mM$   $NaHCO_3$ . There was no recovery with  $K^+$ -HBSS alone. On addition of  $NaHCO_3$ , there was a further acidification followed by a small recovery of  $pH_i$  (fig.5.6). However, the rate of recovery was about a third of that obtained with  $Na^+$ -HBSS alone.

To calibrate fluorescence intensity in terms of  $pH_i$ , the cells were exposed to  $K^+$ -HBSS, containing  $10\mu M$  nigericin. Nigericin tends to set  $pH_o$  (extracellular pH) equal to  $pH_i$  when  $K^+_o$  is equal to  $K^+_i$  (Tolkovsky & Richards, 1987; Madshus, 1988), because of the removal of  $Na^+/H^+$  exchange. Therefore, by using solutions of  $K^+$ -HBSS buffered at different specific  $pH_o$ , it is possible to give a linear calibration of fluorescence in relation to  $pH_o$  over  $pH6.5$  to  $pH7.8$ . (fig.5.7). The mean  $pH_i$  in rat Leydig cells in bicarbonate free normal medium was  $7.18 \pm 0.05$  ( $n=5$ ) when extracellular pH was  $pH7.4$ . This is the pH of the routine incubation medium used for Leydig cell incubations in culture wells.

The influence of alkalization on testosterone production was investigated by

**Fig. 5.4 Sodium ions are required for the recovery intracellular pH after cytoplasmic acidification.** Leydig cells ( $3 \times 10^5$ / coverslip) were incubated for 40mins with BCECF/AM ( $4\mu\text{M}$ ), then washed twice with large volumes of  $\text{Na}^+$ -HBSS. The coverslip was placed diagonally in a square (3ml) cuvette and held in place between two split-Teflon rings. The bathing solution ( $34^\circ\text{C}$ ) was changed continuously by means of a peristaltic pump. The additions of  $\text{NH}_4\text{Cl}$  was made in  $\text{Na}^+$ -HBSS, this solutions was then replaced with  $\text{K}^+$ -HBSS ( $\text{Na}^+$  ions were replaced with  $\text{K}^+$ ). Fluorescence was monitored at an emission of 525nm (slit width, 9nm) and excited at 495nm (slit width, 4.5nm).

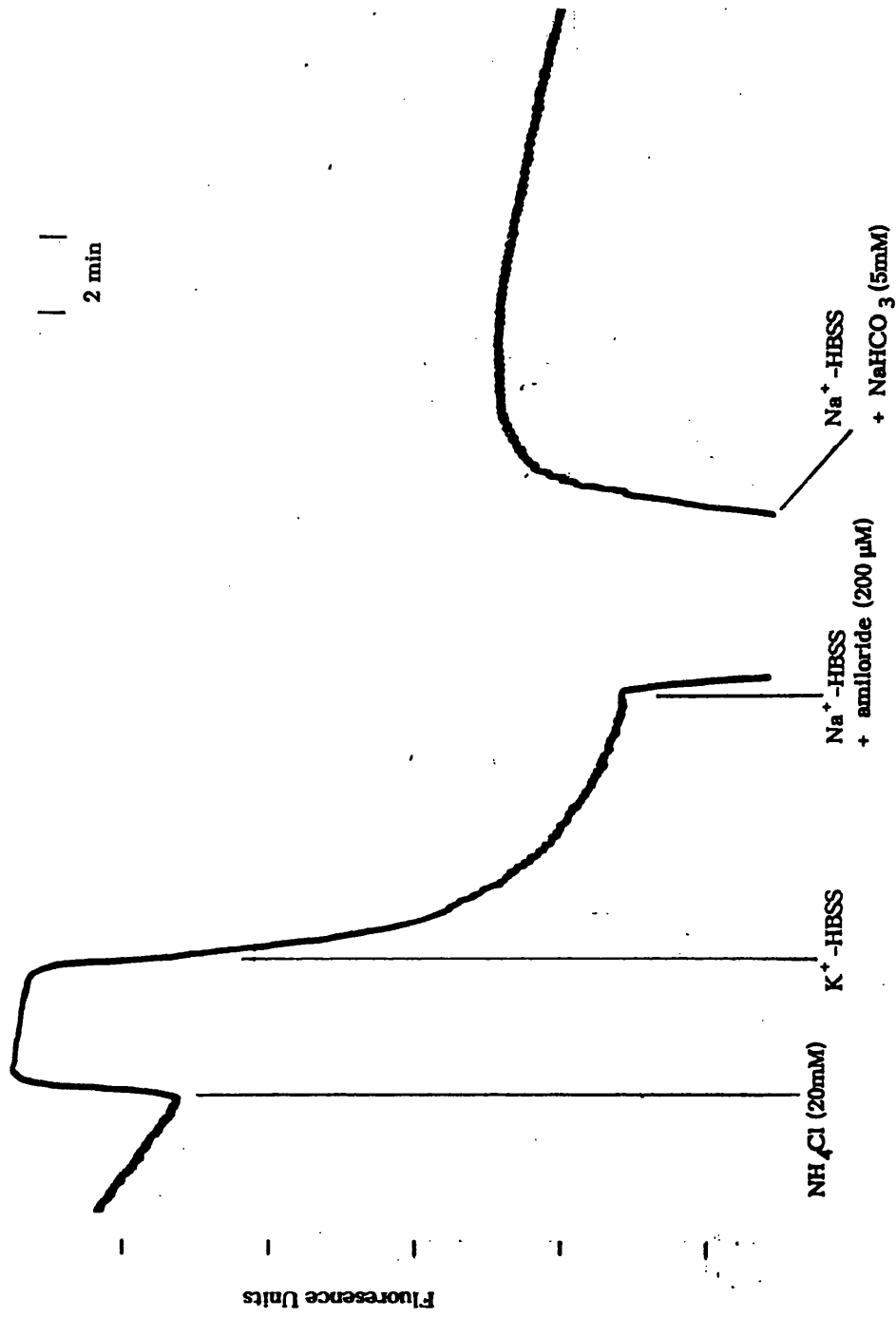
Figure 5.4



**Fig. 5.5 Effect of amiloride, an inhibitor of Na<sup>+</sup>/H<sup>+</sup> exchange, on pH recovery.**

Leydig cells (3 x 10<sup>5</sup>/ coverslip) were incubated for 40mins with BCECF/AM (4μM), then washed twice with large volumes of Na<sup>+</sup>-HBSS. The coverslip was placed diagonally in a square (3ml) cuvette and held in place between two split-Teflon rings. The bathing solution (34°C) was changed continuously by means of a peristaltic pump. The additions of NH<sub>4</sub>Cl was made in Na<sup>+</sup>-HBSS, this solutions was then replaced with K<sup>+</sup>-HBSS (Na<sup>+</sup> ions were replaced with K<sup>+</sup>) and amiloride was added in Na<sup>+</sup>-HBSS. The inhibitory effect of amiloride pH recovery was reversible. Fluorescence was monitored at an emission of 525nm (slit width, 9nm) and excited at 495nm (slit width, 4.5nm).

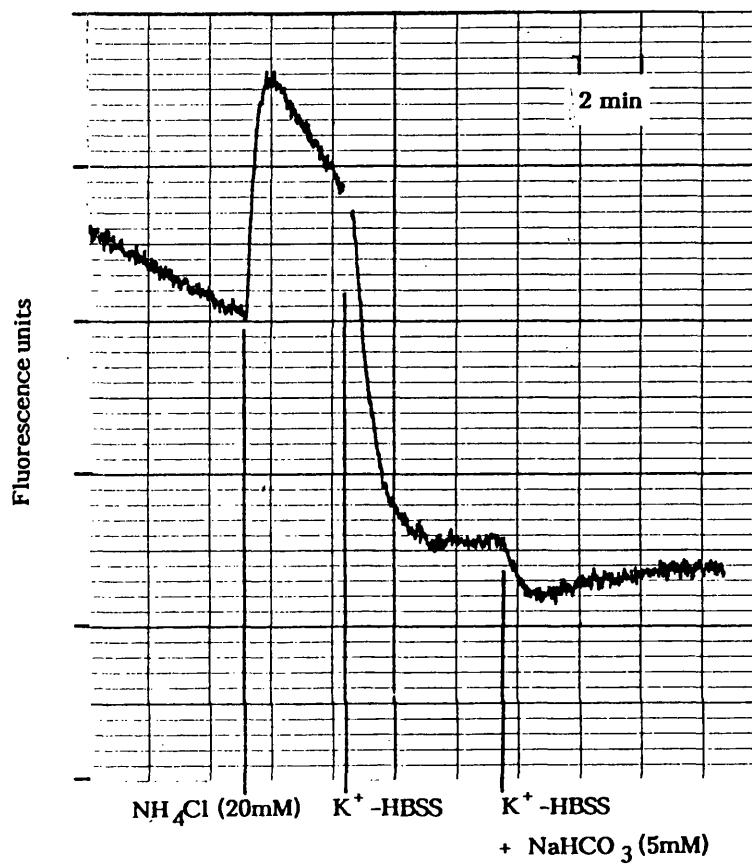
Figure 5.5



**Fig. 5.6 Biocarbonate ions are not sufficient for the recovery of intracellular pH after cytoplasmic acidification.** Leydig cells ( $3 \times 10^5$ / coverslip) were incubated for 40mins with BCECF/AM ( $4\mu\text{M}$ ), then washed twice with large volumes of  $\text{Na}^+$ -HBSS. The coverslip was placed diagonally in a square (3ml) cuvette and held in place between two split-Teflon rings. The bathing solution ( $34^\circ\text{C}$ ) was changed continuously by means of a peristaltic pump. The additions of  $\text{NH}_4\text{Cl}$  was made in  $\text{Na}^+$ -HBSS, this solutions was then replaced with  $\text{K}^+$ -HBSS ( $\text{Na}^+$  ions were replaced with  $\text{K}^+$ ), and  $\text{NaHCO}_3$  was added in  $\text{K}^+$ -HBSS. Fluorescence was monitored at an emission of 525nm (slit width, 9nm) and excited at 495nm (slit width, 4.5nm).



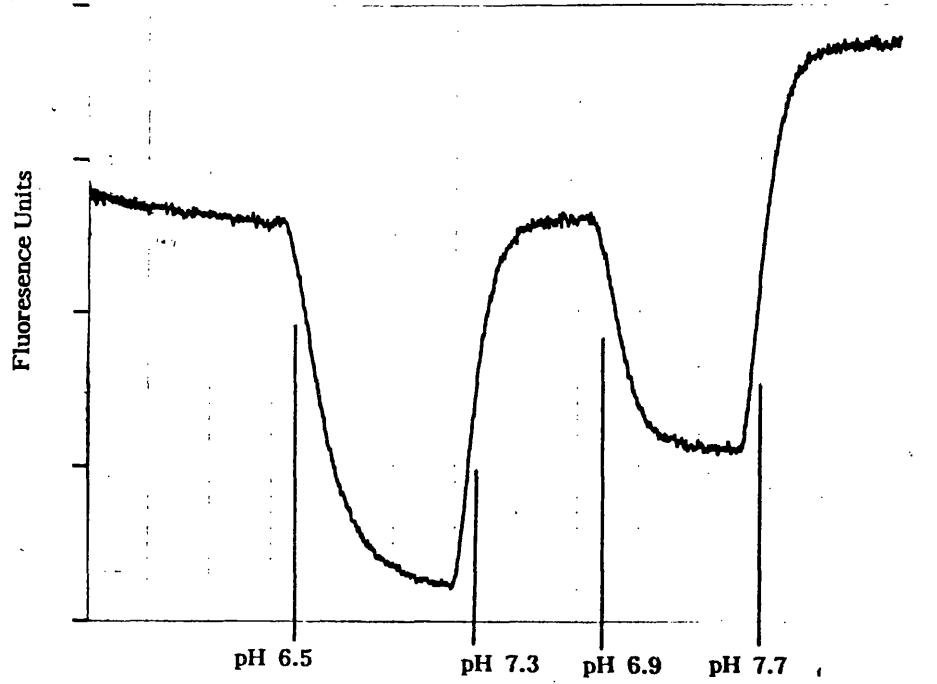
Figure 5.6



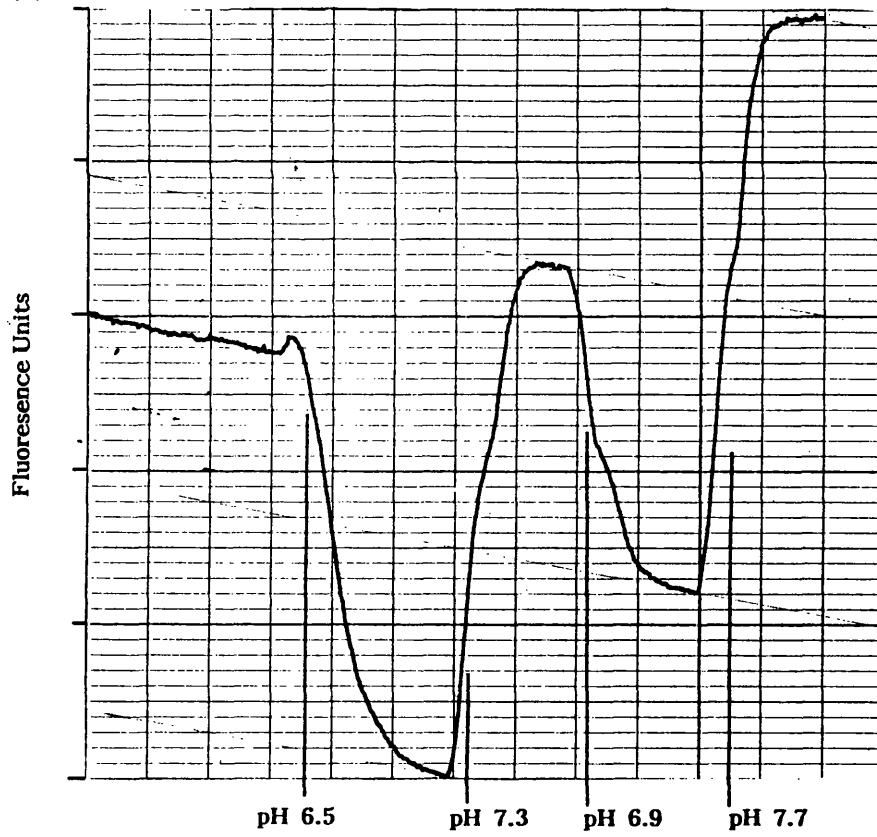
**Fig. 5.7 Calibration of intracellular pH using nigericin, a K<sup>+</sup>-ionophore, in K<sup>+</sup>-HBSS.** Leydig cells (3 x 10<sup>5</sup>/ coverslip) were incubated for 40mins with BCECF/AM (4μM), then washed twice with large volumes of Na<sup>+</sup>-HBSS. The coverslip was placed diagonally in a square (3ml) cuvette and held in place between two split-Teflon rings. The bathing solution (34°C) was changed continuously by means of a peristaltic pump. The cells were superfused with K<sup>+</sup>-HBSS solutions of different pH containing nigericin (10μM). Fluorescence was monitored at an emission of 525nm (slit width, 9nm) and excited at 495nm (slit width, 4.5nm).

Figure 5.7

(A)



(B)



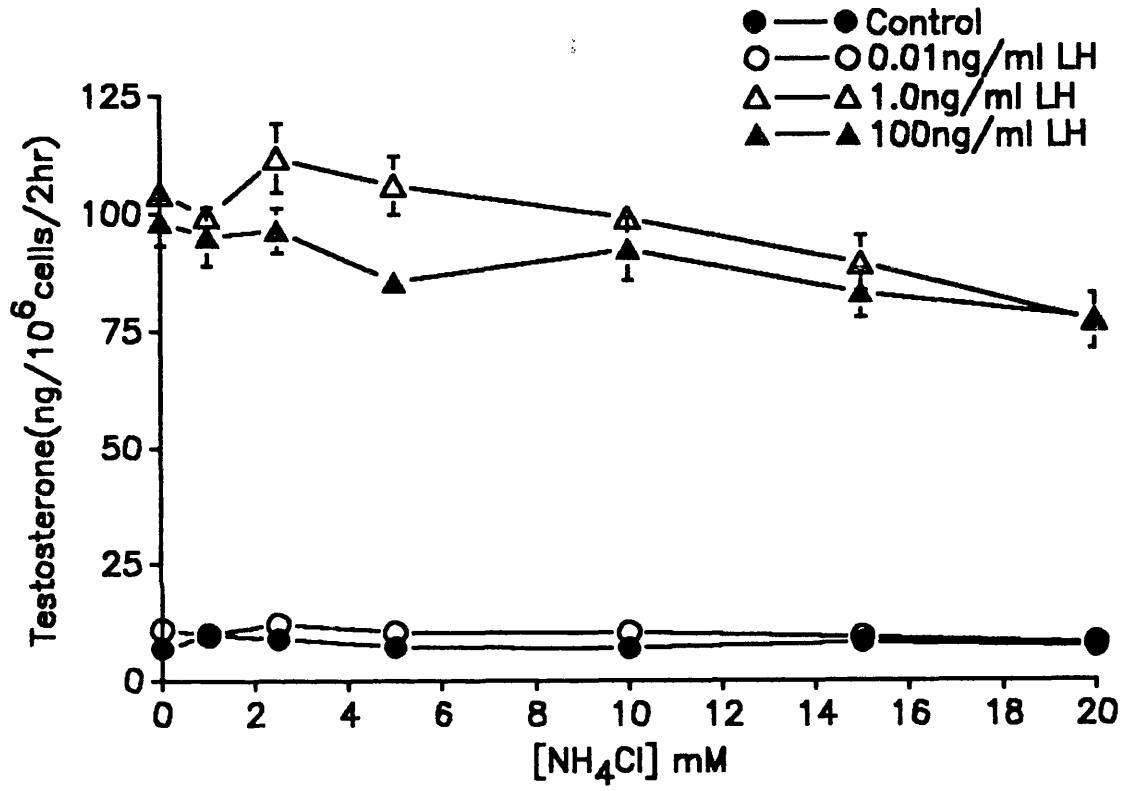
adding  $\text{NH}_4\text{Cl}$  (0 to 20mM) to the incubation medium of Leydig cells. Fig.5.8 shows the lack of effect of  $\text{NH}_4\text{Cl}$ -induced alkalization on LH-stimulated testosterone production.

Similarly, the addition of amiloride (0-400 $\mu\text{M}$ ) to Leydig cells in culture, had no effect on testosterone production (fig.5.9). Amiloride causes intracellular acidification (Lynch et al., 1989), but LH-stimulated testosterone production was unaffected.

The effect of  $\text{NaHCO}_3$  on Leydig cell steroidogenesis was investigated. Over a 2hr incubation there was no difference between Leydig cells incubated in a  $\text{CO}_2$ -incubator (5mM  $\text{NaHCO}_3$ ) and in a air-incubator (control), (fig.5.10).

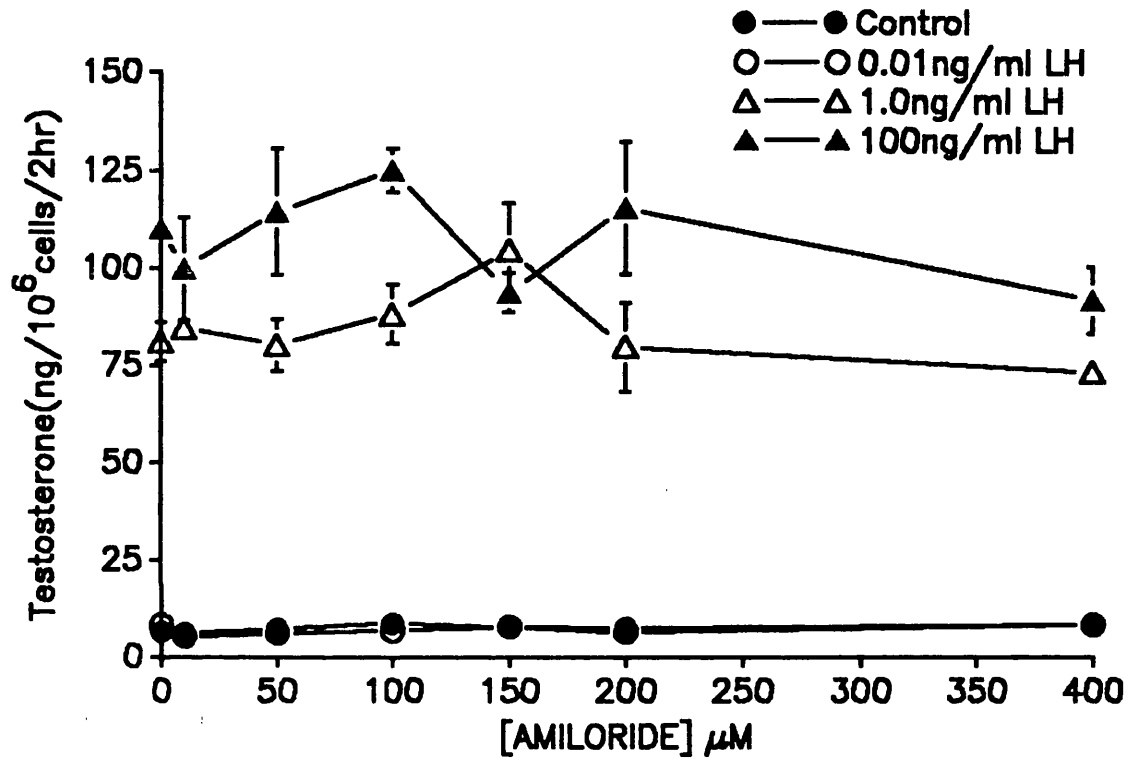
**Fig. 5.8 Effect of NH<sub>4</sub>Cl on LH-stimulated testosterone production.** Leydig cells (2 x 10<sup>4</sup> cells/ well/ 200μl) were incubated in the absence and presence of different concentrations of ammonium chloride, and stimulated with different concentrations of LH for 2 hours. The testosterone produced was determined as described in the Methods. Each point represents the mean ± S.E. for triplicate incubations within one of two similar experiments.

Figure 5.8



**Fig. 5.9 Effect of amiloride on LH-stimulated testosterone production.** Leydig cells ( $2 \times 10^4$  cells/ well/  $200\mu\text{l}$ ) were incubated in the absence and presence of increasing concentrations of amiloride, and stimulated with different concentrations of LH. The testosterone produced was determined as described in the Methods. Each point represents the mean  $\pm$  S.E. for triplicate incubations within one of three similar experiments.

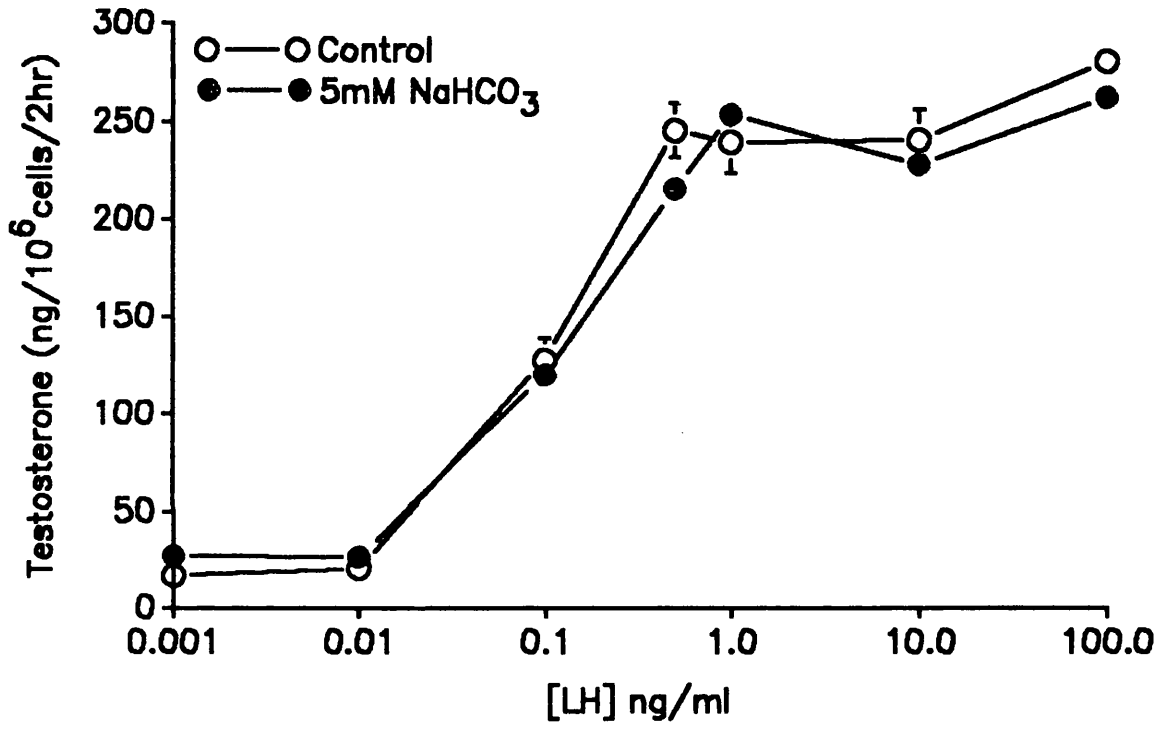
Figure 5.9





**Fig. 5.10 LH-stimulated testosterone production in the presence and absence of NaHCO<sub>3</sub>.** Leydig cells ( $2 \times 10^4$  cells/ well/  $200\mu\text{l}$ ) were incubated for 2 hours in the presence and absence of NaHCO<sub>3</sub> with increasing concentrations of LH. The testosterone produced was measured as described in the Methods. Each point represents the mean  $\pm$  S.E. for triplicate incubations within one of two similar experiments.

Figure 5.10



### 5.3 DISCUSSION

These results demonstrate the presence of an amiloride sensitive  $\text{Na}^+/\text{H}^+$  antiporter for the regulation of  $\text{pH}_i$  in rat Leydig cells. This is in general agreement with all animal cells that have been studied. This antiporter has been well characterised and respond to a fall in  $\text{pH}_i$  by exchanging protons with extracellular  $\text{Na}^+$  (for review, see Krulwich, 1983). It appears that the contribution of bicarbonate-dependent exchangers plays a secondary role in the regulation of basal  $\text{pH}_i$  in rat Leydig cells. However, it is possible that the bicarbonate-transporters may became more important when the cells are stimulated in a bicarbonate containing medium (Thomas, 1989; Ganz et al., 1989).

The inability of rat Leydig cells to recover from an ammonium prepulse when washed with  $\text{K}^+$ -HBSS, demonstrates the presence of a sodium-dependent  $\text{pH}_i$  regulator. However, the role played by these  $\text{pH}_i$  regulators over a 2hr stimulation of testosterone production by LH, does not appear to be very important. The acute stimulation of steroidogenesis by LH, was found not to require bicarbonate in the incubation medium. The addition of 20mM  $\text{NH}_4\text{Cl}$  did not significantly inhibit LH-stimulated testosterone production. This suggests that alkalization does not affect the acute stimulation of steroidogenesis. Addition of amiloride, which causes a slow acidification (Best et al., 1988; Lynch et al., 1989), also had no adverse effect on acute LH-stimulated steroidogenesis. In contrast, amiloride inhibited both angiotensin-II and adrenocorticotropin hormone (ACTH)- induced aldosterone production rat and bovine adrenal glomerulosa cells (Hunyady et al., 1988; Horiuchi et al., 1989). However, for rat glomerulosa cells this was argued to be due to the inhibition of  $\text{Na}^+/\text{Ca}^{2+}$  exchange, since 5-(N,N-hexamethylene)amiloride (HMA), a more specific inhibitor of  $\text{Na}^+/\text{H}^+$  exchange, failed to inhibit aldosterone production.

Despite the apparent lack of pH-dependence of Leydig cell steroidogenesis, it is likely that the long-term maintenance of the steroidogenic capacity is very dependent on  $\text{pH}_i$ . The role of  $\text{pH}_i$  in long-term cultures requires further investigation.

In conclusion, these results have demonstrated the presence of a sodium-dependent and amiloride-sensitive  $\text{pH}_i$ -regulatory system in rat Leydig cells. It was found that the presence of bicarbonate in the superfusion medium was not critical to the recovery from cytosolic acidification. Furthermore, the short-term stimulation of steroidogenesis by LH does not appear to be dependent on the modulation of intracellular pH.

## **CHAPTER SIX**

Chloride ions and Testosterone Production

## 6.1 INTRODUCTION

The modulation of chloride channels is important for the stimulation and regulation of many cellular processes, such as neuronal excitability and the regulation of electrolyte secretion in airway epithelial cells (Frizzell et al., 1986; Lambert et al., 1987; Schoumacher et al., 1987; Welsh, 1990; Quinton, 1990; Dingledine et al., 1990). It has been shown that in rat Leydig cells, using the patch-clamp technique, that an outward chloride current is observed when the cells are dialysed with calcium ( $10^{-7}$  -  $10^{-6}$ M) (Duchatelle and Joffre, 1987). More recently it was shown that gonadotrophins also act through a cyclic AMP-dependent mechanism to activate a chloride conductance. This conductance was different from the calcium-activated chloride conductance in the membrane of resting cells (Duchatelle and Joffre, 1990). However, the role played by these chloride channels in the regulation of steroidogenesis has not been investigated.

Chloride channels exist in a variety of cell types (Virmani et al., 1990; Bahinski et al., 1989; Bretag, 1987; Champigny et al., 1990; Hwang et al., 1990), and are classified according to their unit conductance and sensitivity to chloride channel blockers (Bretag, 1987; Bridges et al., 1989). Some of these chloride channels are linked to calcium channels and are regulated by phosphorylation via protein kinase A or C (Bahinski et al., 1989). In neuronal cells, GABA controlled receptors regulate an inward chloride current. However, the GABA regulated receptors of the glial cells regulate an outward chloride current. GABA-gated chloride channel are insensitive to anion channel blockers such as DIDS and SITS.

This work was carried out to investigate the possible involvement of chloride ions in the regulation of steroidogenesis in rat Leydig cells. The effects of the chloride channel blockers SITS and DIDS on LH-stimulated steroidogenesis were investigated.

## 6.2 RESULTS

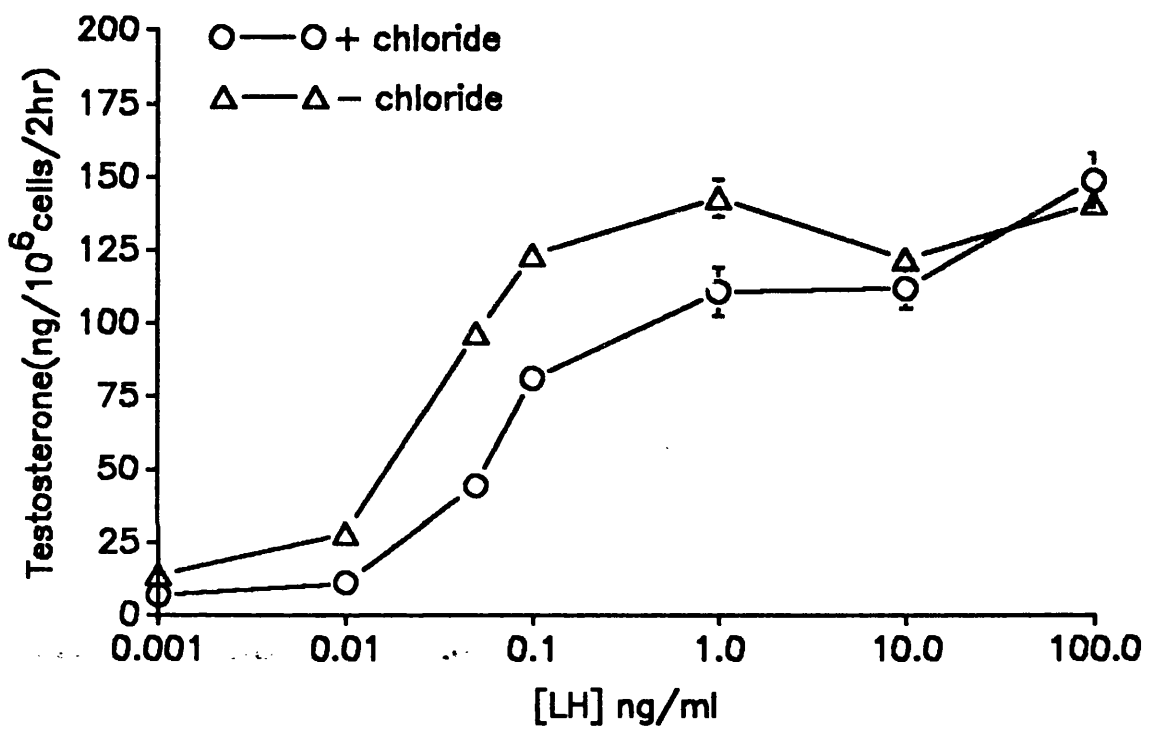
Purified Leydig cells were preincubated for 2 hr, after which the preincubation medium was removed and replaced by a simple salts medium containing glucose. The incubation medium consisted of (in mM): 140 NaCl, 5 KCl, 1.8 Ca-acetate, 1 MgSO<sub>4</sub>, 10 Hepes-NaOH, 10 glucose, pH 7.4, 0.1% BSA. For the removal of chloride, the chloride salts were replaced with equimolar concentrations of the appropriate gluconate salts. The exclusion of extracellular chloride enhanced testosterone production stimulated with submaximal, but not maximal levels of LH (fig.6.1). This effect, caused by removing extracellular chloride, was not exclusive to LH-stimulated testosterone production. It was found that dibutyryl cyclic AMP-stimulated testosterone production was also similarly potentiated (fig.6.2). Maximum testosterone production is normally obtained with 1mM dibutyryl cAMP, but in the absence of extracellular chloride, maximum steroidogenesis was obtained with 0.1mM dibutyryl cAMP. The removal of extracellular chloride caused a greater potentiation of dibutyryl cAMP-stimulated, than LH-stimulated testosterone production. The addition of a phosphodiesterase inhibitor, IBMX, did not alter the potentiating effect caused by the removal of extracellular chloride (fig.6.3). This suggested that the effect of extracellular chloride was not due to the potentiation of cyclic AMP production. This is supported by the lack of effect of removing extracellular chloride on LH-stimulated cyclic AMP production (fig.6.4).

The increased sensitivity of rat Leydig cells to stimulation by LH and dibutyryl cAMP in the absence of extracellular chloride, indicated the possible involvement of chloride channels in the regulation of steroidogenesis. This was assessed using the chloride channel blockers, SITS and DIDS. Initial experiments with SITS (0-200 $\mu$ M),

**Fig. 6.1 Effect of removing extracellular chloride on LH-stimulated testosterone production.** Leydig cells ( $2 \times 10^4$  cells/ well/  $200\mu\text{l}$ ) were incubated for 2 hours with increasing concentrations of LH. The removal of extracellular chloride ions was made by equimolar replacement of the sodium/potassium chloride salts with sodium/potassium gluconate. The testosterone produced was measured as described in the Methods. Each point represents the mean  $\pm$  S.E. for triplicate incubations within one of at least three similar experiments.

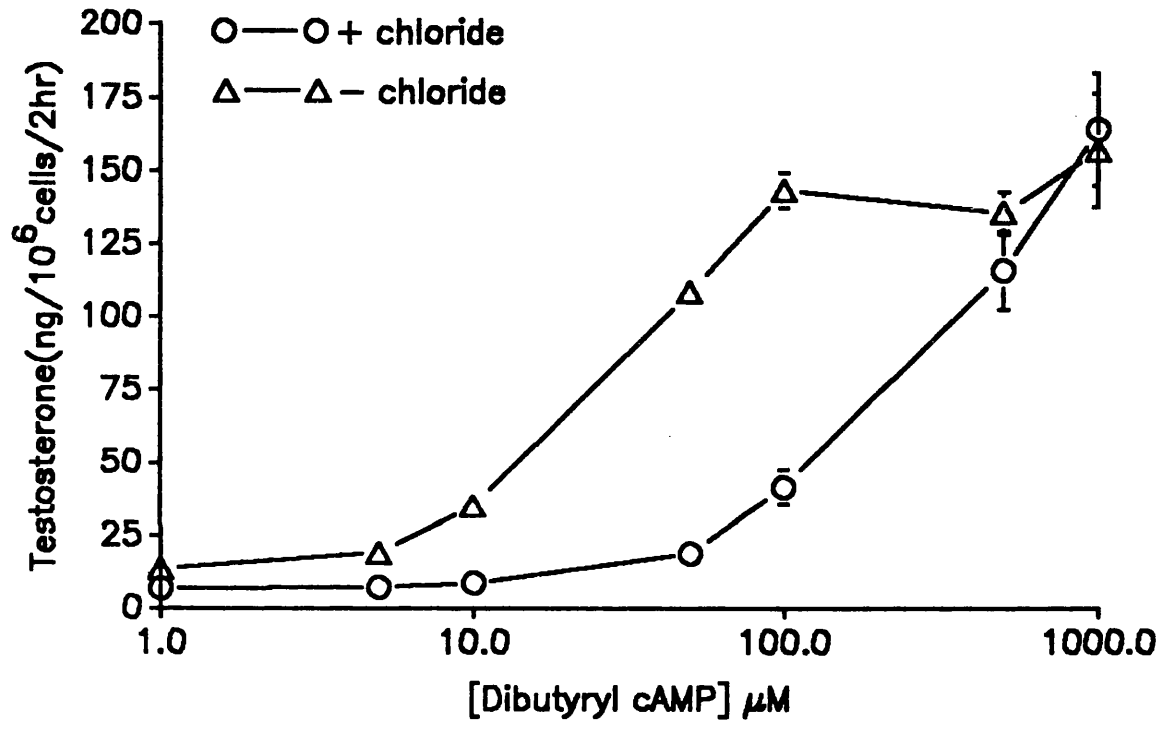


Figure 6.1



**Fig. 6.2 Effect of removing extracellular chloride on dibutyryl cAMP-stimulated testosterone production.** Leydig cells ( $2 \times 10^4$  cells/ well/  $200\mu\text{l}$ ) were incubated for 2 hours with increasing concentrations of dibutyryl cAMP. The removal of extracellular chloride ions was made by equimolar replacement of the sodium/potassium chloride salts with sodium/potassium gluconate. The testosterone produced was measured as described in the Methods. Each point represents the mean  $\pm$  S.E. for triplicate incubations within one of at least three similar experiments.

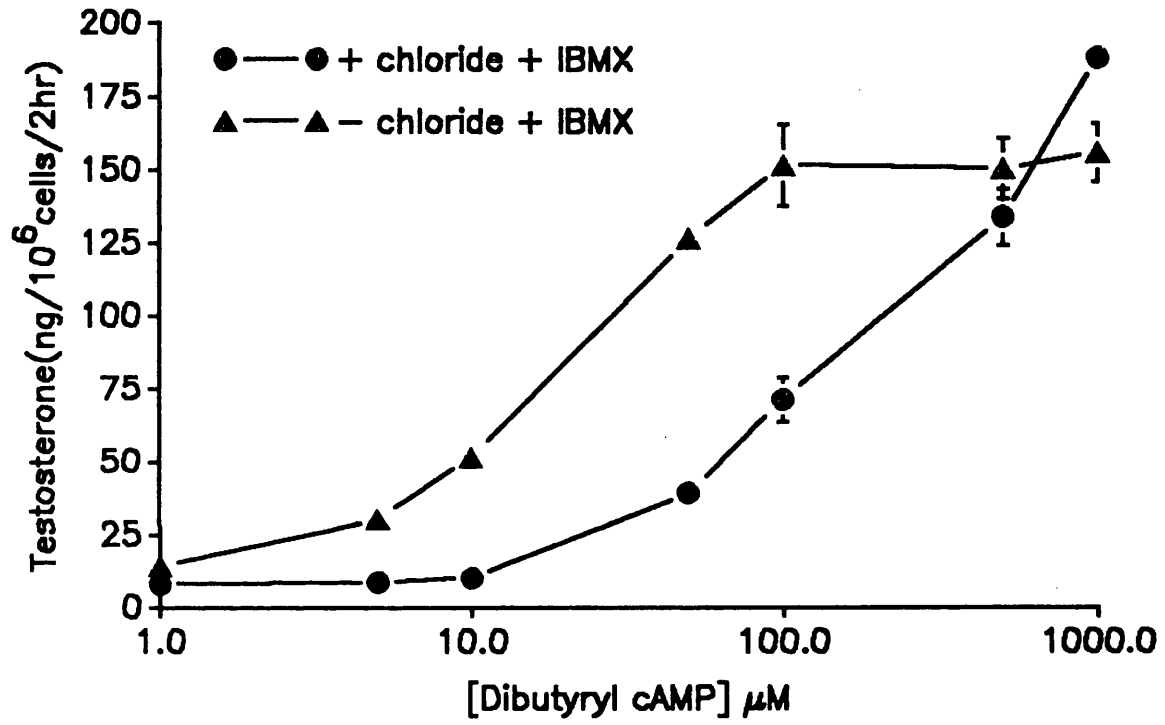
Figure 6.2



**Fig. 6.3 Effect of removing extracellular chloride on dibutyryl cAMP-stimulated testosterone production in the presence of the phosphodiesterase inhibitor, IBMX.**

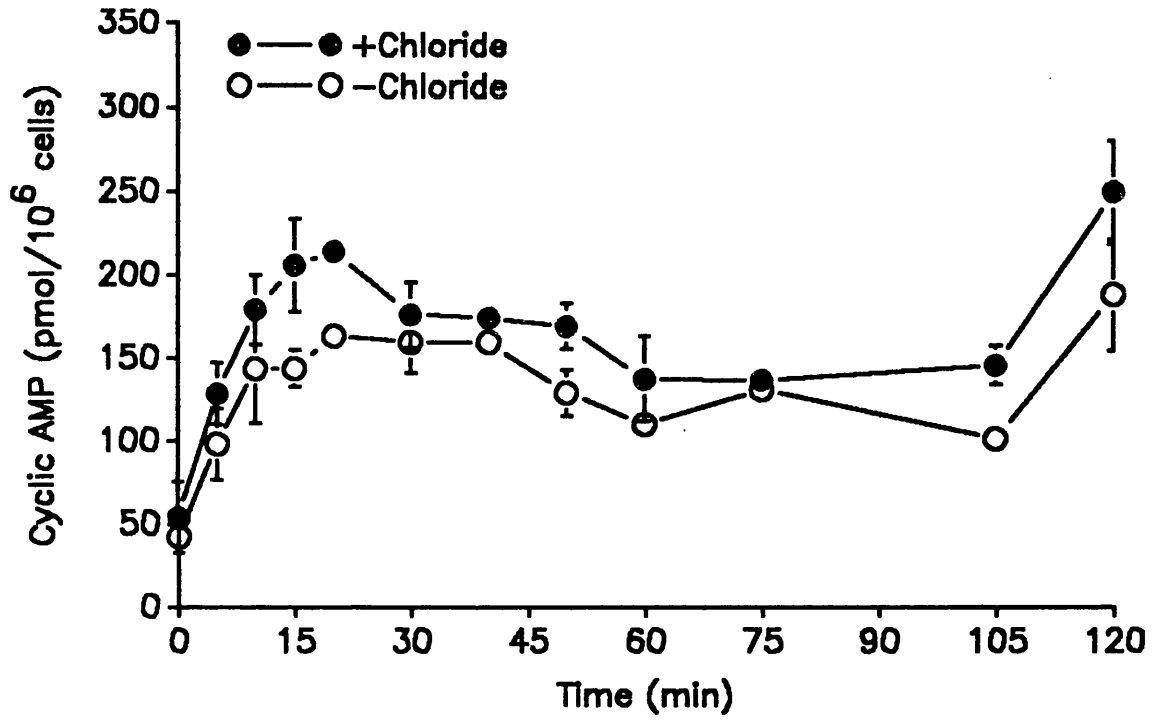
Leydig cells ( $2 \times 10^4$  cells/ well/  $200\mu\text{l}$ ) were incubated for 2 hours with increasing concentrations of dibutyryl cAMP. The removal of extracellular chloride ions was made by equimolar replacement of the sodium/potassium chloride salts with sodium/potassium gluconate. The testosterone produced was measured as described in the Methods. Each point represents the mean  $\pm$  S.E. for triplicate incubations within one of two similar experiments.

Figure 6.3



**Fig. 6.4** The time-course of LH-stimulated cyclic AMP production in the presence and absence of extracellular chloride with IBMX. Leydig cells ( $1 \times 10^5$  cells/ well/  $500\mu\text{l}$ ) were incubated with LH (100ng/ml) for the times indicated and then washed twice with 1ml of fresh medium, and then stopped with perchloric acid . The removal of extracellular chloride ions was made by equimolar replacement of the sodium/potassium chloride salts with sodium/potassium gluconate. The intracellular cyclic AMP was measured as described in the Methods. Each point represents the mean  $\pm$  S.D. for triplicate incubations within one of two similar experiments.

Figure 6.4



showed differential effects on LH- and dibutyryl cAMP-stimulated testosterone production (fig.6.5). Inhibition of steroidogenesis was only seen with concentrations of LH  $\geq 1$  ng/ml, and not with 100 ng/ml LH. Dibutyryl cyclic AMP-stimulated testosterone production was unaffected by SITS. This was confirmed by taking the  $ID_{50}$  concentration of SITS for LH (1 ng/ml)-stimulated steroidogenesis, and investigating its effect on the dose-response curve of dibutyryl cAMP-stimulated testosterone production (fig.6.6). These observations indicated that SITS does not inhibit cyclic AMP-stimulated testosterone production. However, the addition of a phosphodiesterase inhibitor, IBMX, together with SITS (100  $\mu$ M) was able to restore LH (1 ng/ml)-stimulated testosterone production to control levels (fig.6.7).

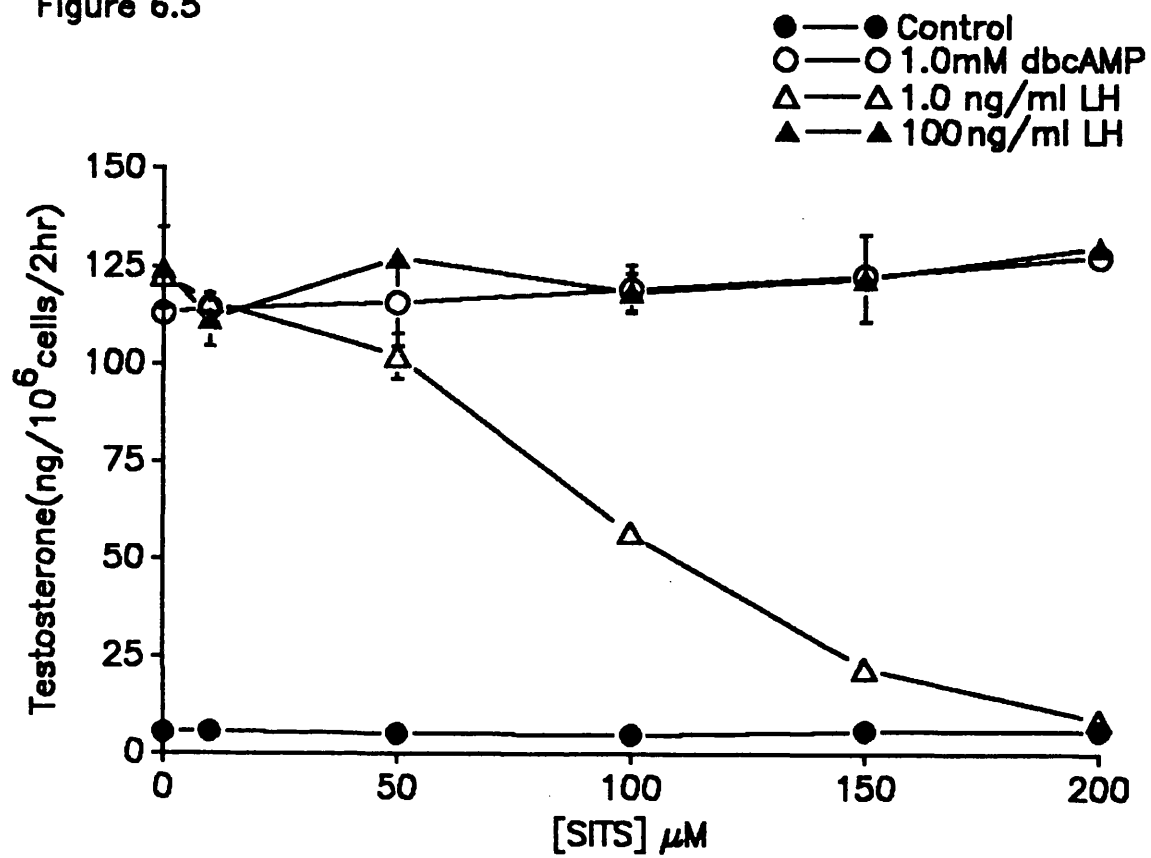
Further experiments were carried out using DIDS. In agreement with the results obtained with SITS, testosterone production was unaffected by different concentrations of DIDS (0-100  $\mu$ M) in the presence of maximum stimulating levels of dibutyryl cAMP (fig.6.8). In addition, 100  $\mu$ M DIDS had no effect on steroidogenesis stimulated with submaximal concentrations of dibutyryl cyclic AMP (fig.6.9). However, testosterone production stimulated by 1 and 100 ng/ml LH were dose-dependently inhibited by DIDS with  $ID_{50}$ s of approximately 25  $\mu$ M and 50  $\mu$ M respectively (fig.6.8). This is in contrast to the inhibition of LH-stimulated testosterone production by SITS, where there was no inhibition of testosterone production stimulated with 100 ng/ml LH. The inhibition of LH-stimulated testosterone production by DIDS (100  $\mu$ M), could be removed by the addition of dibutyryl CAMP to the incubation medium (fig.6.10), indicating that DIDS may be inhibiting LH-stimulated cyclic AMP production.

To investigate whether DIDS-sensitive chloride channels are involved in the potentiation of steroidogenesis caused by the removal of extracellular chloride. DIDS



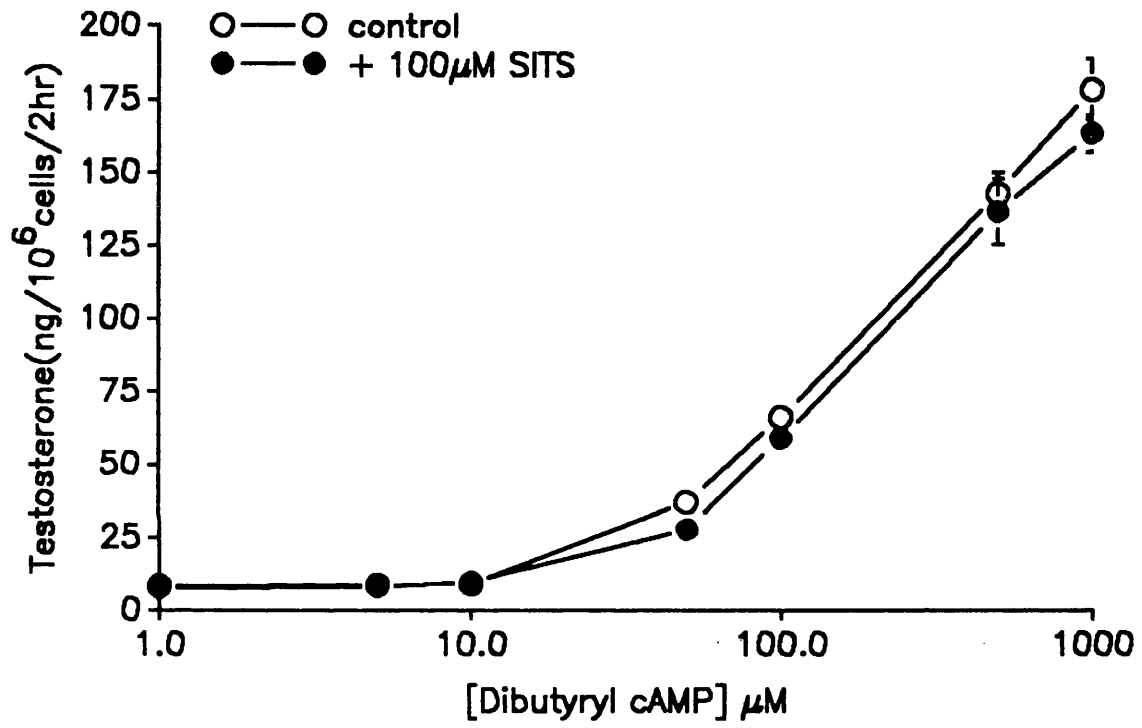
**Fig. 6.5 Effect of SITS, an inhibitor of chloride channels, on LH and dibutyryl cAMP-stimulated testosterone production.** Leydig cells ( $2 \times 10^4$  cells/ well/  $200\mu\text{l}$ ) were incubated for 2 hours with dibutyryl cAMP (1mM) or LH (1.0 and 100ng/ml) in the absence and presence of increasing concentrations of SITS. The testosterone produced was measured as described in the Methods. Each point represents the mean  $\pm$  S.E. for triplicate incubations within one of three similar experiments.

Figure 6.5



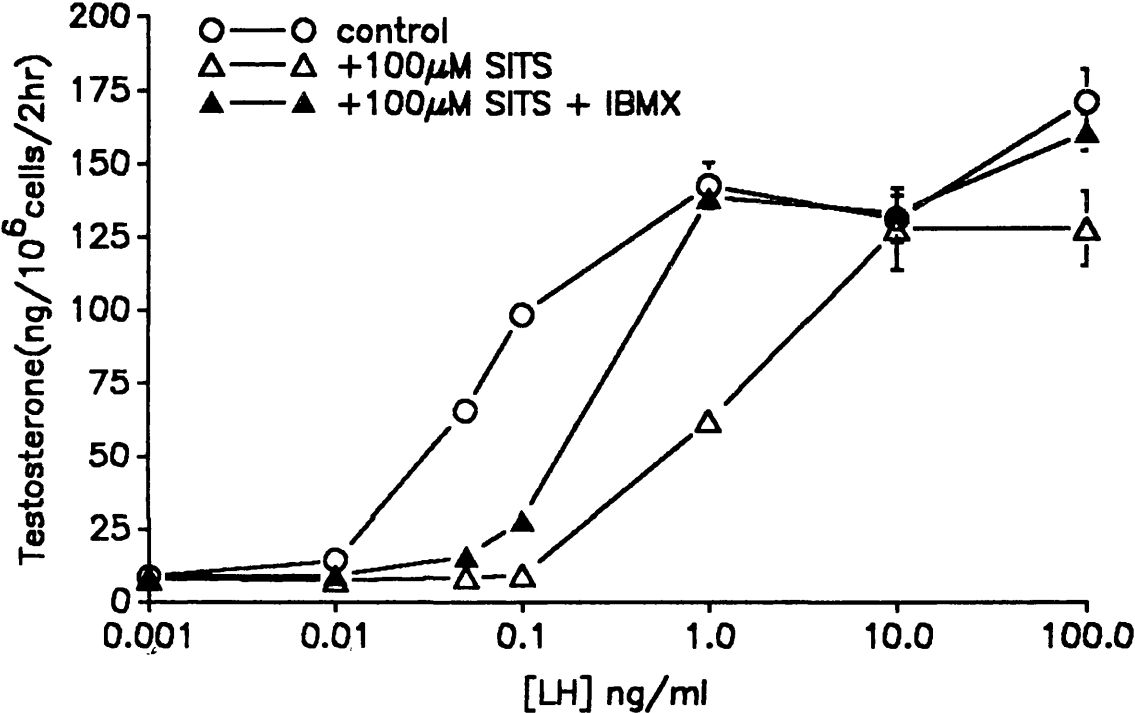
**Fig. 6.6 Effect of SITS, an inhibitor of chloride channels, on dibutyryl cAMP-stimulated testosterone production.** Leydig cells ( $2 \times 10^4$  cells/ well/  $200\mu\text{l}$ ) were incubated for 2 hours with increasing concentrations of dibutyryl cAMP absence and presence of SITS ( $100\mu\text{M}$ ). The testosterone produced was measured as described in the Methods. Each point represents the mean  $\pm$  S.E. for triplicate incubations within one of two similar experiments.

Figure 6.6



**Fig. 6.7** Effect of SITS, an inhibitor of chloride channels, on LH-stimulated testosterone production in the presence and absence of IBMX. Leydig cells ( $2 \times 10^4$  cells/ well/  $200\mu\text{l}$ ) were incubated for 2 hours with increasing concentrations of LH in the absence and presence of SITS ( $100\mu\text{M}$ ) and SITS ( $100\mu\text{M}$ ) plus IBMX. The testosterone produced was measured as described in the Methods. Each point represents the mean  $\pm$  S.E. for triplicate incubations within one of two similar experiments.

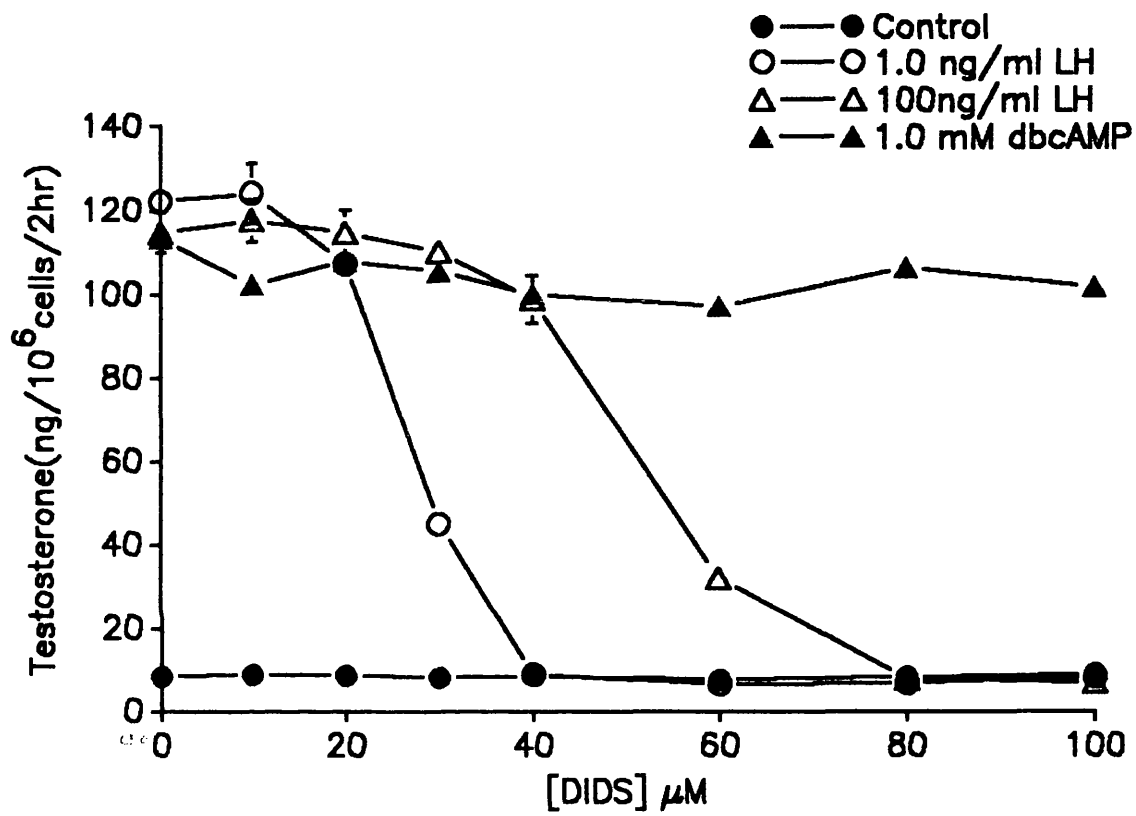
Figure 6.7



**Fig. 6.8 Effect of DIDS, an inhibitor of chloride channels, on LH- and dibutyryl cAMP-stimulated testosterone production.** Leydig cells ( $2 \times 10^4$  cells/ well/  $200\mu\text{l}$ ) were incubated for 2 hours with LH (1.0 and 100ng/ml) and dibutyryl cAMP (1mM) in the absence and presence of increasing concentrations of DIDS. The testosterone produced was measured as described in the Methods. Each point represents the mean  $\pm$  S.E. for triplicate incubations within one of two similar experiments.



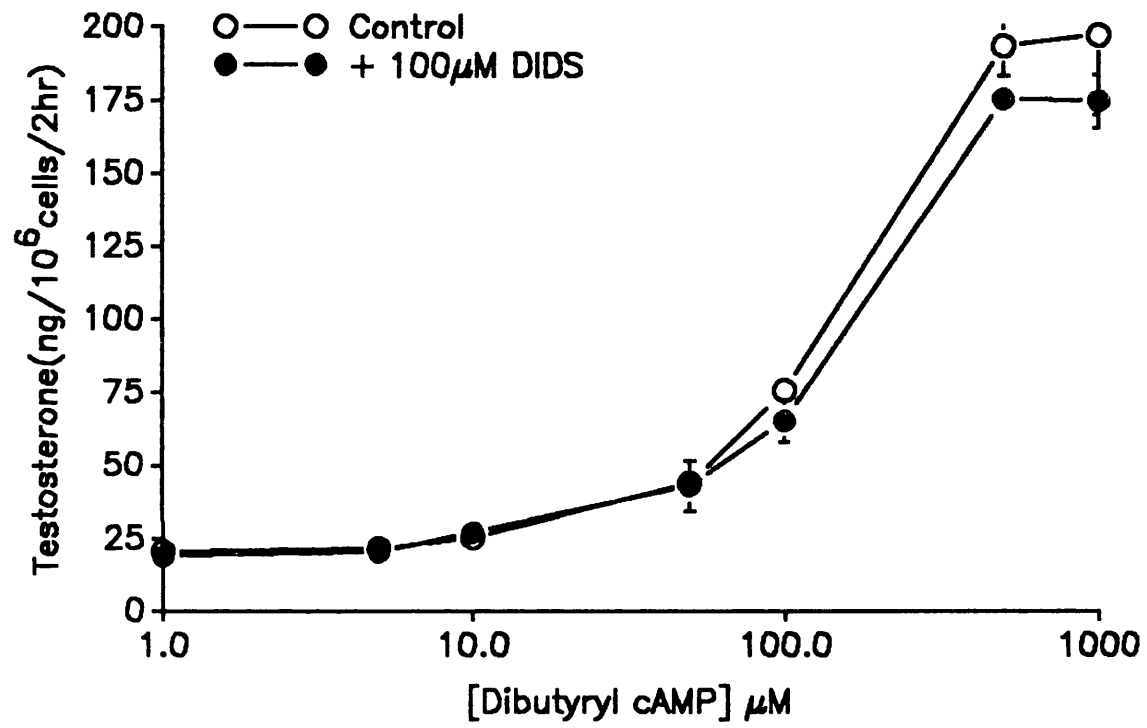
Figure 6.8





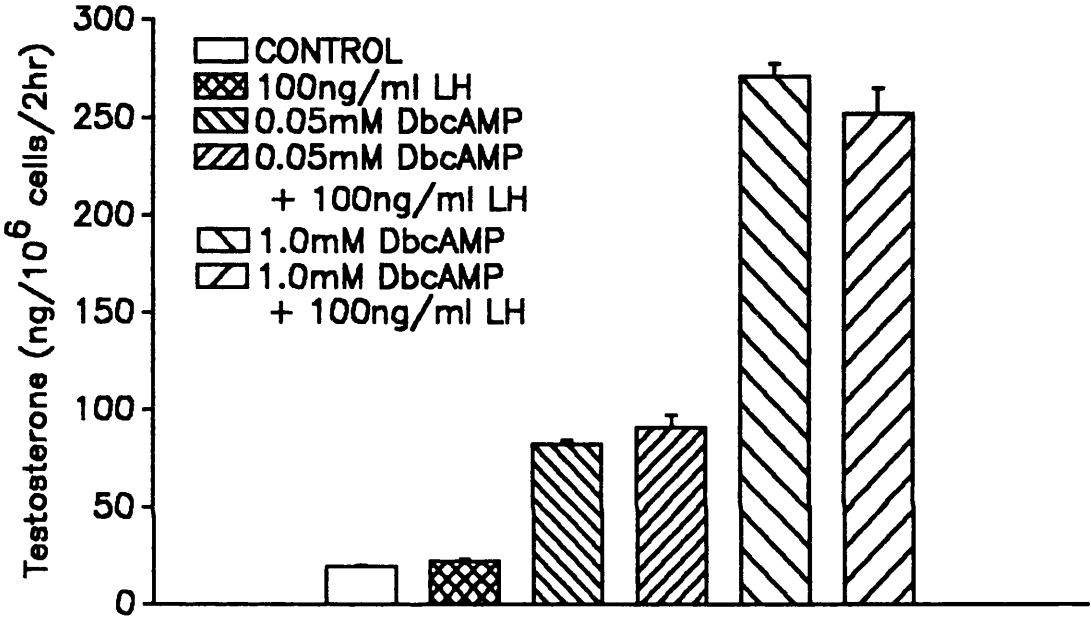
**Fig. 6.9 Effect of DIDS, an inhibitor of chloride channels, on dibutyryl cAMP-stimulated testosterone production.** Leydig cells ( $2 \times 10^4$  cells/ well/  $200\mu\text{l}$ ) were incubated for 2 hours with increasing concentrations of dibutyryl cAMP absence and presence of DIDS ( $100\mu\text{M}$ ). The testosterone produced was measured as described in the Methods. Each point represents the mean  $\pm$  S.E. for triplicate incubations within one of two similar experiments.

Figure 6.9



**Fig. 6.10** Effect of DIDS, an inhibitor of chloride channels, on dibutyryl cAMP-stimulated testosterone production in the presence and absence of LH. Leydig cells ( $2 \times 10^4$  cells/ well/  $200\mu\text{l}$ ) were incubated for 2 hours with LH (100ng/ml) alone, and dibutyryl cAMP (0.05 and 1.0mM) +/- LH (100ng/ml), all in the presence of DIDS ( $100\mu\text{M}$ ). The testosterone produced was measured as described in the Methods. Each point represents the mean  $\pm$  S.D. for triplicate incubations within one experiment.

Figure 6.10



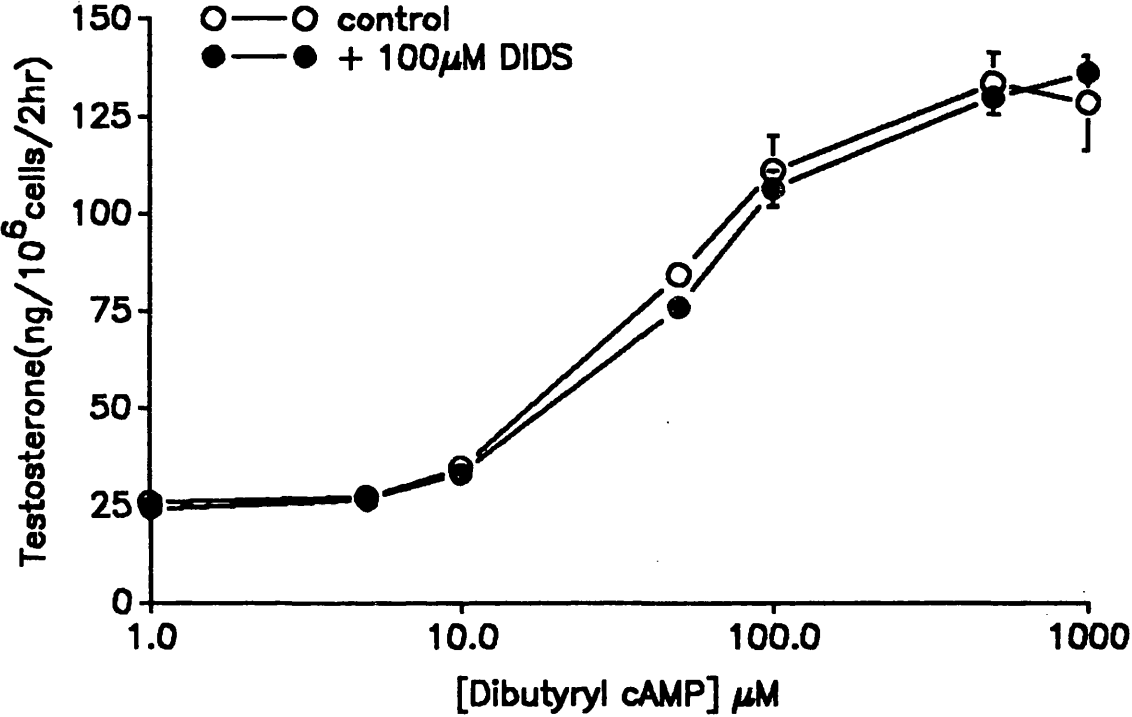
(100 $\mu$ M) was added to cells incubated in the absence of extracellular chloride and stimulated by both submaximal and maximal concentrations of dibutyryl cyclic AMP. DIDS (100 $\mu$ M) did not inhibit the effect caused by the removal of extracellular chloride, over the entire dose-range of dibutyryl CAMP (0-100 $\mu$ M) (fig.6.11).

The effect of DIDS on cyclic AMP production was investigated in Leydig cells stimulated with LH (100ng/ml), forskolin (10 $\mu$ M) and cholera toxin (10 and 50 $\mu$ g/ml). Figure 6.12 shows the dose-dependent inhibition of LH and forskolin-stimulated cyclic AMP by DIDS. Forskolin-stimulated cyclic AMP was decreased by two-thirds by 1 $\mu$ M DIDS, and was not further inhibited by higher concentrations of DIDS. However, LH-stimulated cyclic AMP was decreased to basal levels by increasing concentrations of DIDS. In contrast, cyclic AMP production stimulated with cholera toxin was not affected by DIDS (fig.6.13). However, the levels of cyclic AMP stimulated by cholera toxin were below those stimulated by both LH and forskolin. Also, the level of forskolin-stimulated cyclic AMP remaining even after the inhibitory effect of DIDS was still higher than those stimulated by cholera toxin.

To assess whether the potentiating effect of removing extracellular chloride ions on steroidogenesis is restricted to Leydig cells, investigations were carried out in rat adrenocortical cells. The replacement of chloride ions with gluconate, methanesulphonate or isethionate ions, markedly potentiated submaximal pregnenolone production in response to dibutyryl cAMP (Fig. 6.14). However, in the case of replacement of chloride ions with gluconate ions, there was also an inhibition of the maximum level of pregnenolone produced. The reason for the inhibitory effect of gluconate ions on maximal pregnenolone production in these cells is not clear.

**Fig. 6.11 Effect of DIDS, an inhibitor of chloride channels, on dibutyryl cAMP-stimulated testosterone production in the absence of extracellular chloride.** Leydig cells ( $2 \times 10^4$  cells/ well/  $200\mu\text{l}$ ) were incubated for 2 hours with increasing concentrations of dibutyryl cAMP absence and presence of DIDS ( $100\mu\text{M}$ ) in the absence of extracellular chloride. The removal of extracellular chloride ions was made by equimolar replacement of the sodium/potassium chloride salts with sodium/potassium gluconate. The testosterone produced was measured as described in the Methods. Each point represents the mean  $\pm$  S.E. for triplicate incubations within one of two similar experiments.

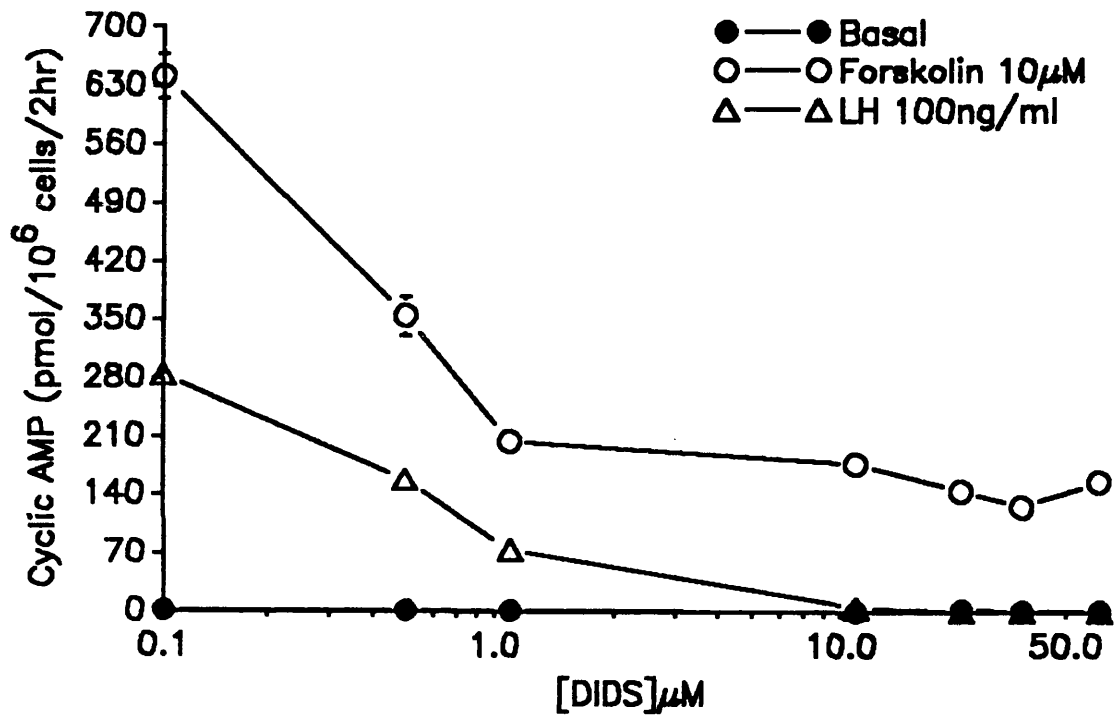
Figure 6.11



**Fig. 6.12 Effect of DIDS, an inhibitor of chloride channels, on LH- and forskolin-stimulated cyclic AMP production.** Leydig cells ( $2 \times 10^4$  cells/ well/  $200\mu\text{l}$ ) were incubated for 2 hours with LH (100ng/ml) and forskolin ( $10\mu\text{M}$ ) in the absence and presence of increasing concentrations of DIDS. The cyclic AMP produced was measured as described in the Methods. Each point represents the mean  $\pm$  S.E. for triplicate incubations within one of two similar experiments.

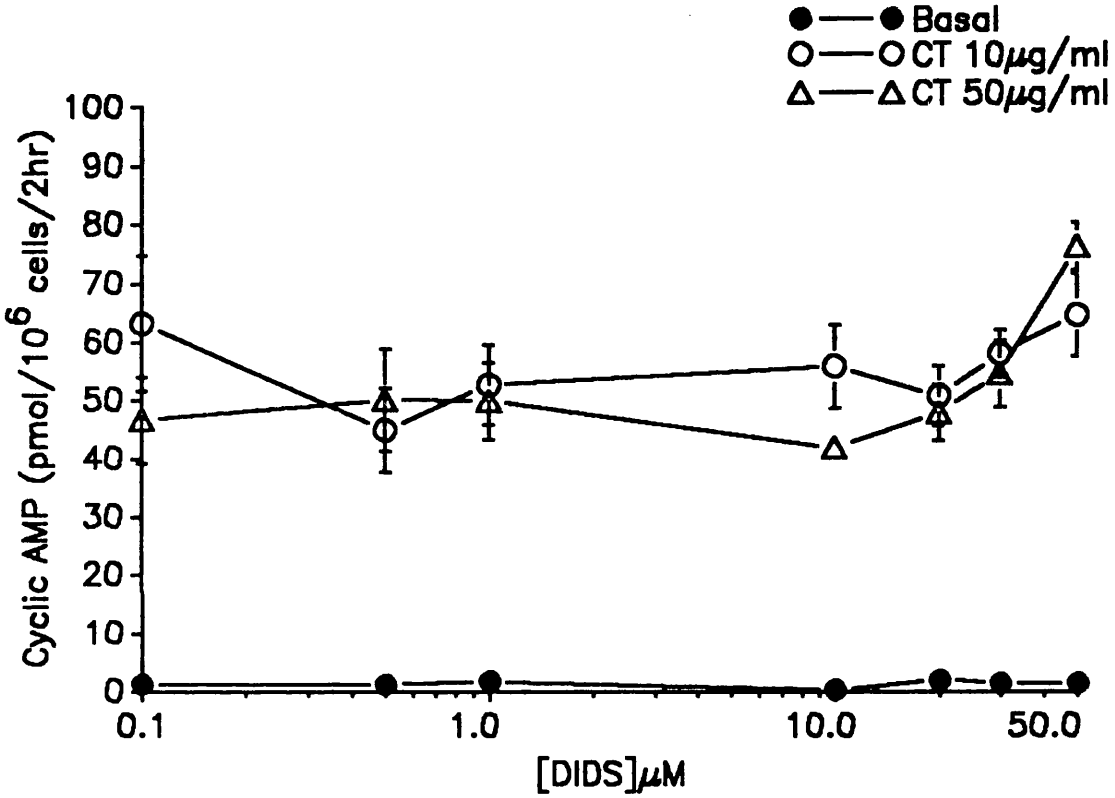


Figure 6.12



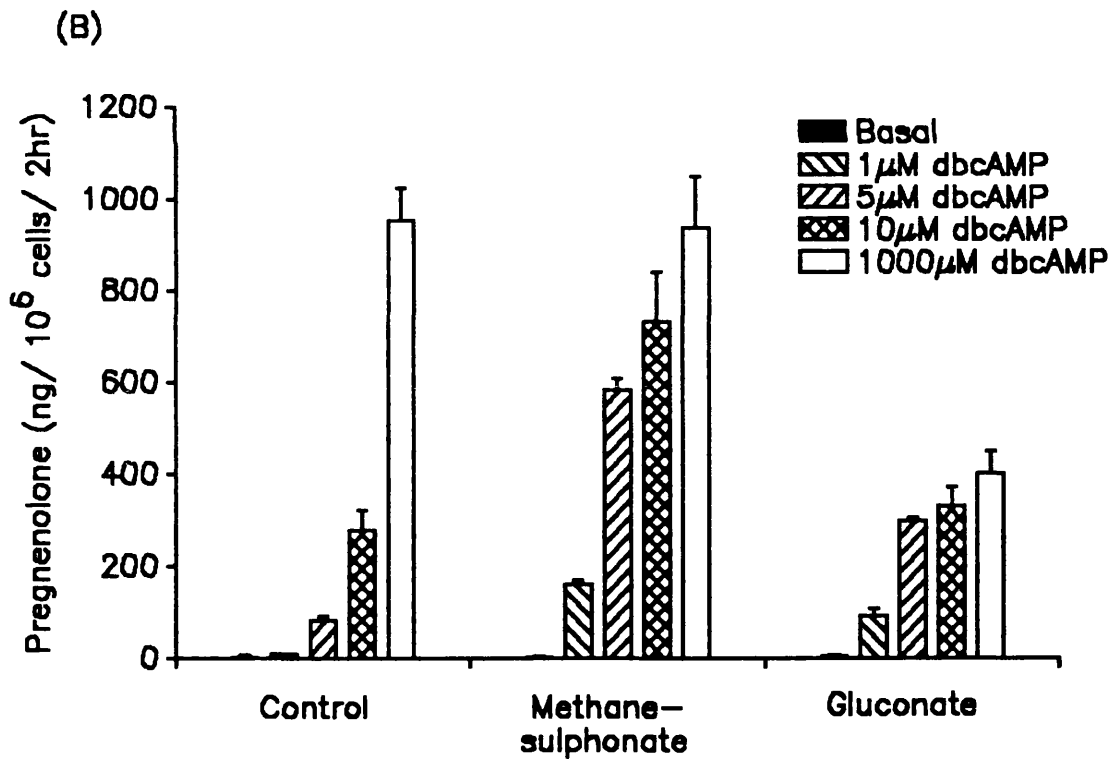
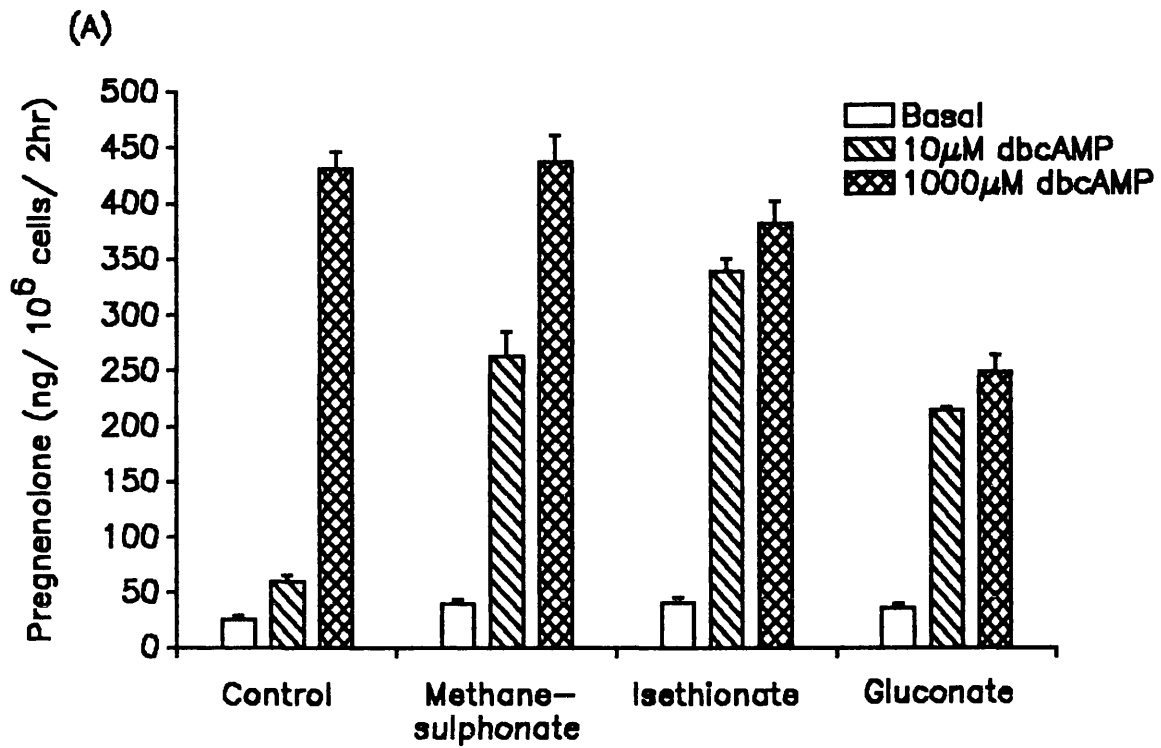
**Fig. 6.13** Effect of DIDS, an inhibitor of chloride channels, on cholera toxin-stimulated cyclic AMP production. Leydig cells ( $2 \times 10^4$  cells/ well/  $200\mu\text{l}$ ) were incubated for 2 hours with cholera toxin ( $10$  and  $50\mu\text{g/ml}$ ) in the absence and presence of increasing concentrations of DIDS. The cyclic AMP produced was measured as described in the Methods. Each point represents the mean  $\pm$  S.E. for triplicate incubations within one experiment.

Figure 6.13



**Fig. 6.14 Effect of removing extracellular chloride on dibutyryl cAMP-stimulated pregnenolone production in adrenocortical cells.** Adrenocortical cells ( $2 \times 10^4$  cells/well/  $200\mu\text{l}$ ) were incubated for 2 hours with increasing concentrations of dibutyryl cAMP. The removal of extracellular chloride ions was made by equimolar replacement of the sodium/potassium chloride salts with sodium/potassium gluconate, isethionate or methanesulphonate salts. The pregnenolone produced was measured as described in the Methods. Each point represents the mean  $\pm$  S.E. for triplicate incubations within one experiment. Figs. 6.14A and 6.14B are results from two different experiments.

Figure 6.14



### 6.3 DISCUSSION

The dissociation between testosterone and cyclic AMP production (see chapter 3, fig.3.1), has given rise to the suggestion that different transducing mechanisms in addition to the production of cyclic AMP, could mediate testosterone production at low concentrations of LH. The initial results demonstrate that LH-stimulated steroidogenesis was inhibited by the chloride channel antagonist SITS. This inhibition was obtained only with LH concentrations  $\leq 1\text{ng/ml}$  and not at  $100\text{ng/ml}$ . Inhibition was not seen when cyclic AMP was the stimulating agent, such as dibutyryl cyclic AMP and forskolin- ( $1,5$  and  $10\mu\text{M}$ ). Even at concentrations of forskolin and dibutyryl cAMP where steroidogenesis was submaximal, SITS had no effect. These results suggest that chloride movements are important for the stimulation of steroidogenesis, at concentrations of LH that stimulate little or no cyclic AMP synthesis. In addition, the potentiation of submaximal LH-stimulated testosterone production by chloride exclusion, could argue for a stimulating role of an outward chloride current. Therefore, these initial observations suggested that at low levels of LH, steroidogenesis was dependent on chloride channels whereas with high levels of LH, cyclic AMP was the mediator of LH action.

Later experiments with the chloride channel inhibitor, DIDS, showed that testosterone production stimulated with all concentrations of LH was inhibited by DIDS, although progressively higher concentrations were required for inhibition as the stimulating concentration of LH was increased. This argued against the involvement of chloride channels in steroidogenesis only when simulated with low levels of LH. The different observations with SITS and DIDS could be explained by differences in their potencies for the inhibition of chloride channels. Apart from this difference, the action of DIDS and SITS on steroidogenesis were similar.

The lack of effect of SITS and DIDS on forskolin and dibutyryl cAMP-stimulated testosterone production suggest that these compounds may be acting through the inhibition of cyclic AMP production at a site prior to the activation of adenylate cyclase. Support for this is given by the ability of IBMX to partially reverse the inhibitory effect of SITS (100 $\mu$ M) on LH-stimulated testosterone production, and also the ability of dibutyryl cyclic AMP to overcome the inhibition of LH-stimulated testosterone production by DIDS (100 $\mu$ M). When cyclic AMP production was measured, this was shown to be the case. The inhibition of both LH- and forskolin- stimulated cyclic AMP production suggested multiple sites of action of DIDS. The effect of DIDS on the action of forskolin suggests one of these sites to be the adenylate cyclase enzyme, but the inhibition was incomplete and this is reflected in the lack of effect of DIDS on forskolin-stimulated testosterone production. The other site of action appears to be at the LH-receptor, since DIDS has no effect on cholera toxin-stimulated cyclic AMP production. However, the possibility exists that SITS and DIDS may also be inhibiting a chloride-dependent pathway involved in the stimulation of testosterone production by LH, which is independent of cyclic AMP production.

The potentiation of both submaximal LH- and dibutyryl cyclic AMP- stimulated testosterone production by the removal of extracellular chloride, suggest that this effect is via processes distal to the production of cyclic AMP. This conclusion is supported by its lack of effect on LH-stimulated cyclic AMP production. Furthermore, the addition of IBMX did not remove the potentiation of steroidogenesis, caused by the removal of extracellular chloride. The effect of removing extracellular chloride does not appear to be via SITS- or DIDS-sensitive chloride channels. This is supported by the inability of 100 $\mu$ M DIDS to inhibit the potentiation of steroidogenesis caused by the removal of

extracellular chloride. However, a more detailed dose-response to the progressive removal of extracellular chloride is required, in order to fully assess its effects on testosterone production. However, it is clear that the potentiating effect of removing extracellular chloride on steroidogenesis can also be demonstrated in rat adrenocortical cells using different replacement ions. This suggests that chloride ions may influence fundamental processes in the stimulation of steroidogenesis.

To summarize, these results have demonstrated that exclusion of extracellular chloride ions can potentiate steroidogenesis. The effects of SITS and DIDS suggests that chloride channels may be involved in the action of LH. However, non-specific effects and the direct influence of SITS and DIDS on LH/receptor interactions cannot be ruled out, as suggested by the inhibition of cyclic AMP production.



## **CHAPTER SEVEN**

The Role of de novo Cholesterol Synthesis and Acute  
Testosterone Production

## **7.1 INTRODUCTION**

Testosterone is synthesized from cholesterol (for details see chapter 1.). Most of the cholesterol is synthesized within the testis (Morris and Chaikoff, 1959; Eik-Nes, 1975), which is in contrast to the adrenal gland and ovary, where lipoprotein cholesterol is the major source for steroid biosynthesis (Gwynne and Strauss, 1982). Therefore, regulation of intracellular cholesterol biosynthesis may be an important site for the action of LH.

It has been clearly demonstrated that HMG-CoA reductase, which catalyses the conversion of HMG-CoA to mevalonate, is the rate-controlling enzyme for cholesterol biosynthesis (review, Goldstein and Brown). This enzyme can be inhibited by several fungal agents. These include, compactin and lovastatin (mevinolin), which inhibit the enzyme competitively at concentrations of less than  $10^{-8}$  M (Endo, 1988). In cultured cells, they block the synthesis of mevalonate, but the effects of the inhibition are reversed by the addition of 10mM mevalonate to the culture medium (Brown et al., 1978; Nakanishi et al., 1988).

In the following experiments the possibility of cholesterol biosynthesis being a site for the acute regulation of steroidogenesis in rat Leydig cells was investigated. The effects of compactin and mevalonate on testosterone production were determined.

## 7.2 RESULTS

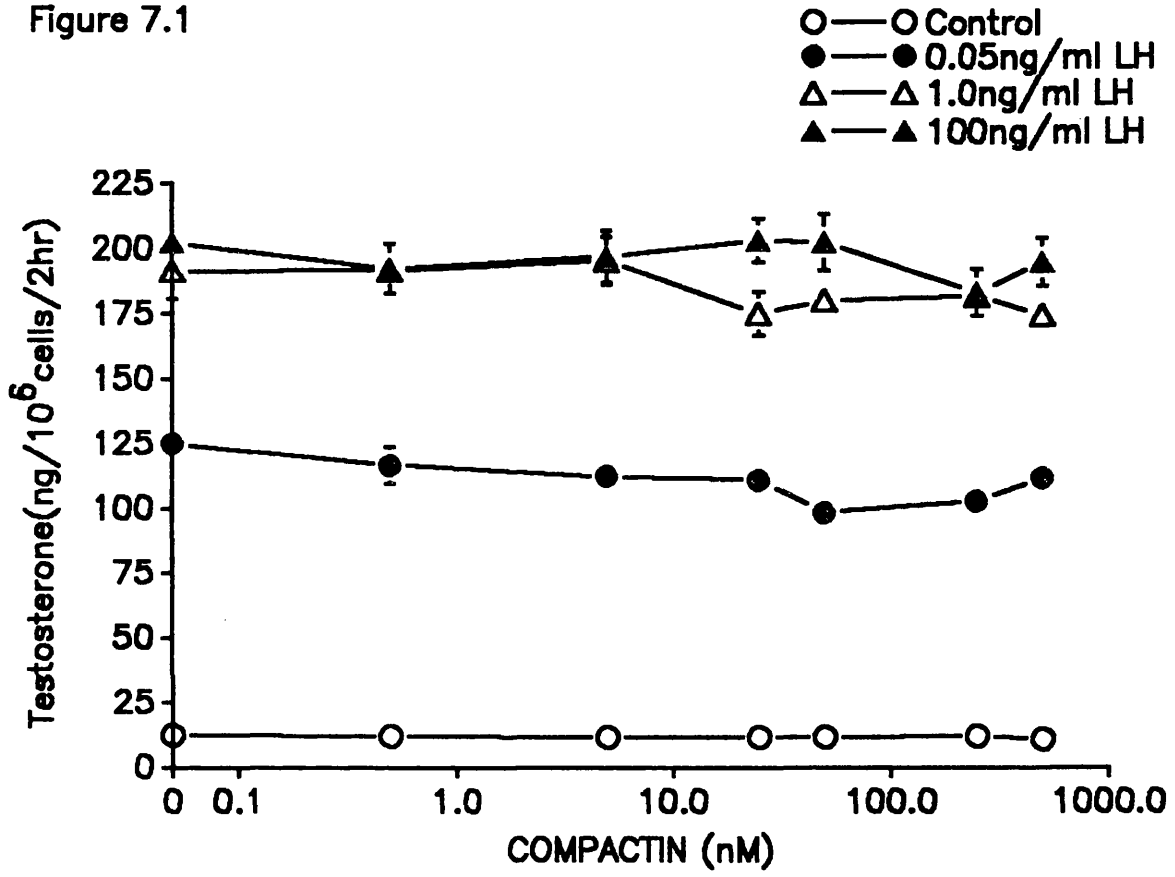
Compactin was added to the Leydig cells at concentrations of up to 500nM; no effect on basal or LH-stimulated testosterone production was found (Fig.7.1). Similarly, dibutyryl cyclic AMP-stimulated testosterone production was unaffected by compactin (Fig.7.2). Testosterone production stimulated by agents which by-pass cyclic AMP such as calmidazolium and 22(R)OH-cholesterol, were also unaffected by compactin (0-500nM), (Fig.7.3).

Because of the lack of effect of low concentrations of compactin, higher concentrations (0.1-100 $\mu$ M) were investigated. With these concentrations of compactin, dibutyryl cyclic AMP- and LH- stimulated testosterone were dose-dependently inhibited with an ED<sub>50</sub> of approximately 50 $\mu$ M (Fig.7.4). However, this inhibition was not reversed on the addition of 10mM mevalonate to the incubation medium. The possible non-specific effect of high concentrations of compactin were investigated by measuring the conversion of 22(R)OH-cholesterol to testosterone (Fig.7.5). The conversion of 22(R)OH-cholesterol to testosterone was also dose-dependently inhibited by these higher concentrations of compactin, although inhibition was not complete. In the same experiment, calmidazolium-stimulated testosterone production was not inhibited. However, the level of testosterone stimulated by calmidazolium was lower than the compactin-inhibited levels supported by 22(R)OH-cholesterol.

The addition of mevalonate to the incubation medium did not stimulate basal testosterone production (Fig.7.6). The progressive equimolar replacement of glucose with mevalonate had no effect on testosterone production.

**Fig. 7.1** The effect of compactin, an inhibitor of HMGCoA reductase, on LH-stimulated testosterone production. Leydig cells ( $2 \times 10^4$  cells/ well/  $200\mu\text{l}$ ) were incubated for 2 hours in the absence and presence of increasing concentrations of compactin, and stimulated with different concentrations of LH. The testosterone produced was measured as described in the Methods. Each point represent the mean  $\pm$  S.E. for triplicate incubations within one of two similar experiments.

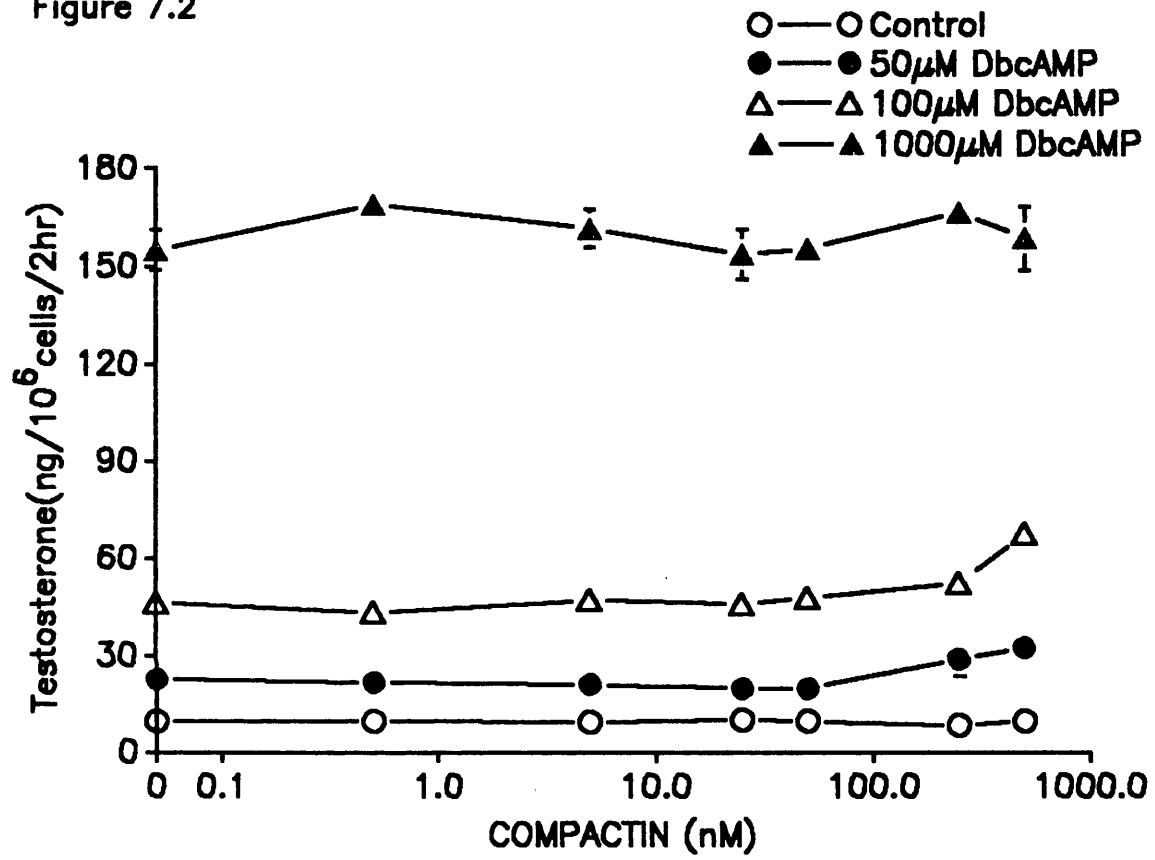
Figure 7.1



**Fig. 7.2 Effect of compactin on dibutyryl cAMP-stimulated testosterone production.**

Leydig cells ( $2 \times 10^5$  / well /  $200\mu\text{l}$ ) were incubated in the absence and presence of increasing concentrations of compactin, and stimulated for 2 hours with dibutyryl cAMP. The testosterone produced was measured in the incubation media as described in the Methods. Each point represents the mean  $\pm$  S.E. for triplicate incubations within one of two similar experiments.

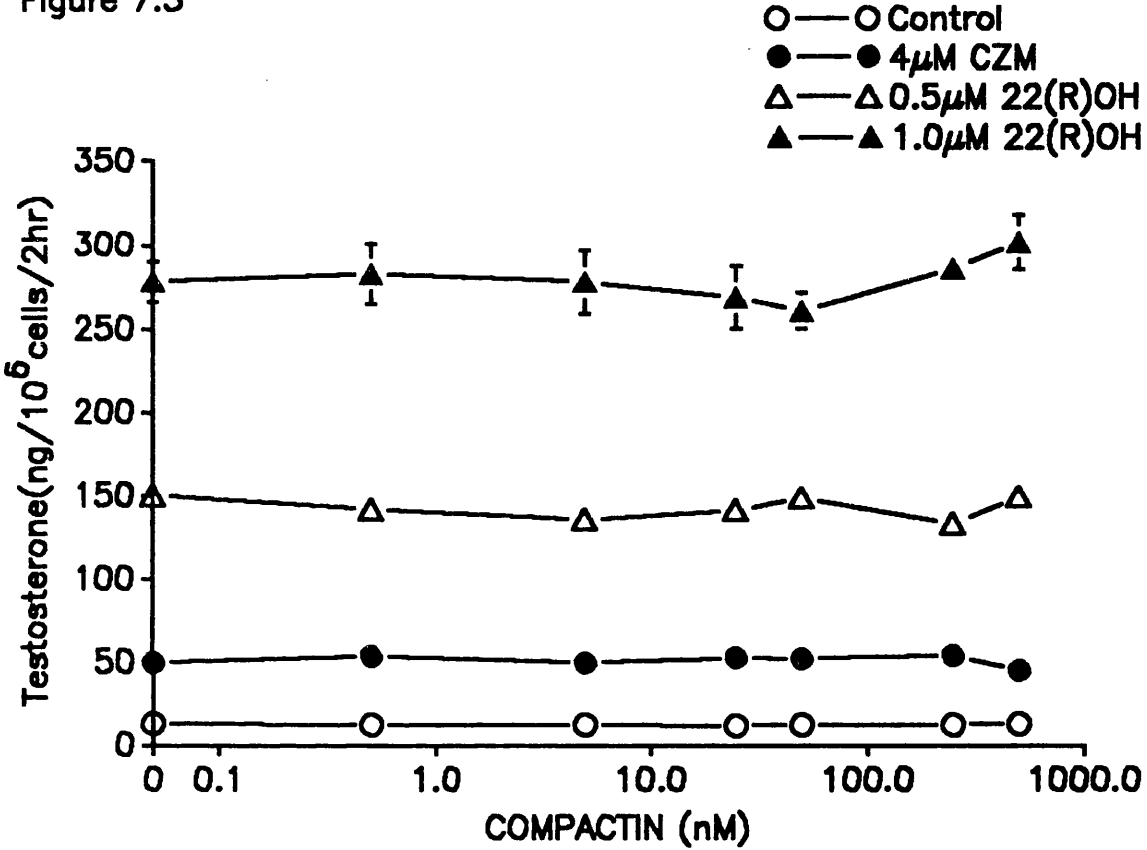
Figure 7.2



**Fig. 7.3** Effect of compactin on calmidazolium-stimulated, and the conversion of 22(R)OH-cholesterol to testosterone in Leydig cells. Leydig cells ( $2 \times 10^4$ / well/  $200\mu\text{l}$ ) were incubated for 2 hours with 22(R)OH-cholesterol ( $0.5\mu\text{M}$  and  $1.0\mu\text{M}$ ) and calmidazolium (CZM,  $4\mu\text{M}$ ), in the presence of increasing concentrations of compactin. The testosterone produced was measured as described in the Methods. Each point represents the mean  $\pm$  S.E. for triplicate incubations within one of two similar experiments.

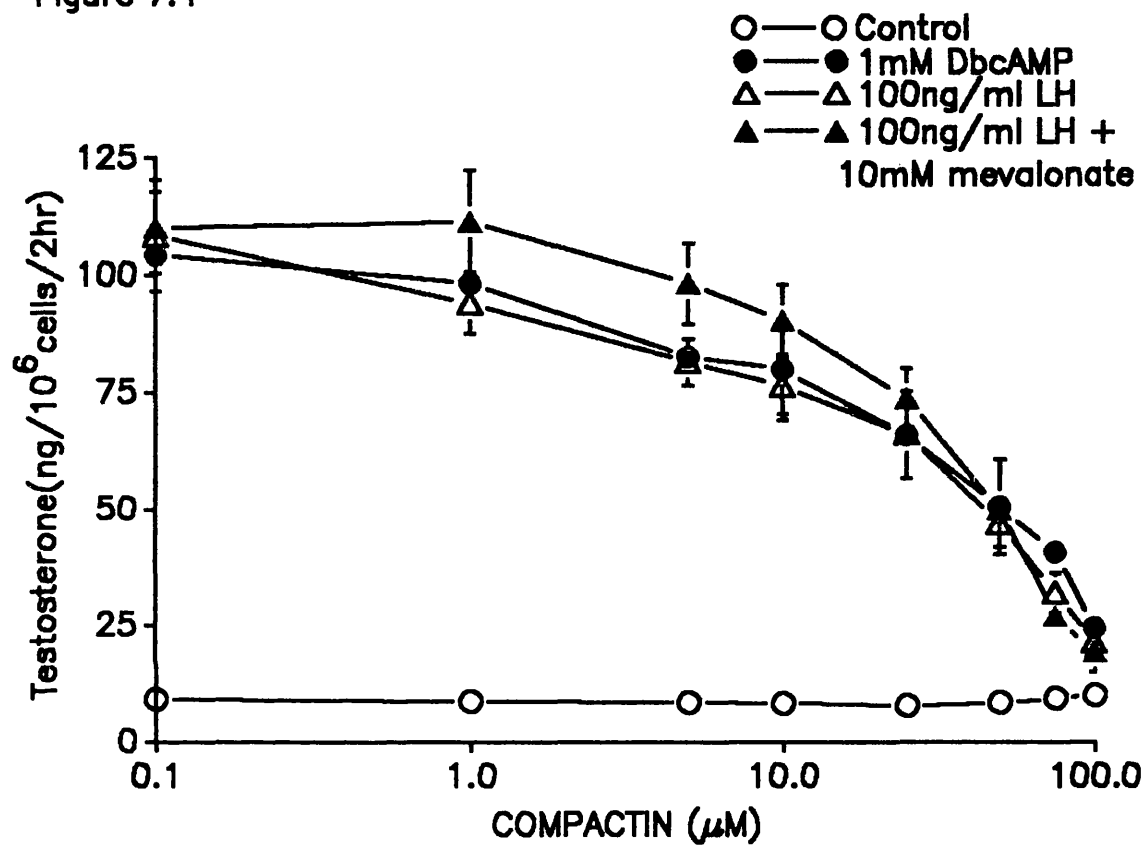


Figure 7.3



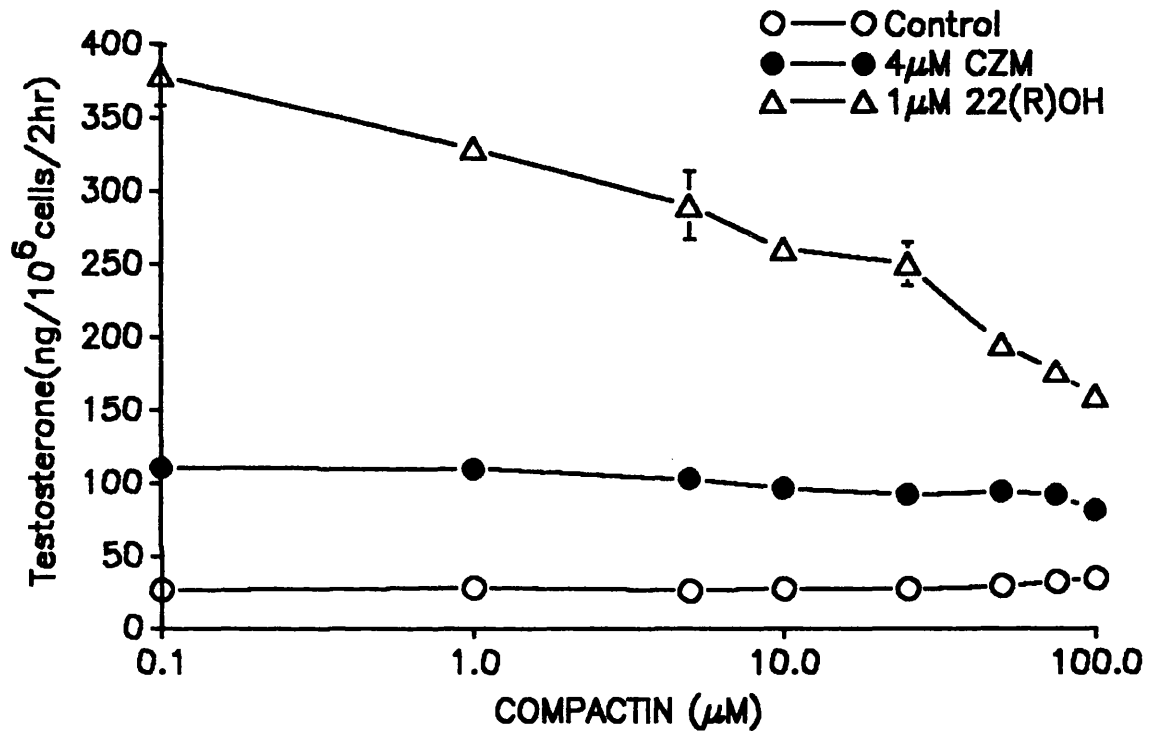
**Fig. 7.4 Effect of higher concentrations of compactin on dibutyryl cAMP-and LH-stimulated testosterone production.** Leydig cells ( $2 \times 10^4$ / well/  $200\mu\text{l}$ ) were incubated for 2 hours in the presence of increasing concentrations of compactin, and stimulated with dibutyryl cAMP (1mM), LH (100ng/ml) and LH (100ng/ml) plus mevalonate (10mM). The testosterone produced was measured according to the Methods. Each point represents the mean  $\pm$  S.E. for triplicate incubations within one experiment.

Figure 7.4



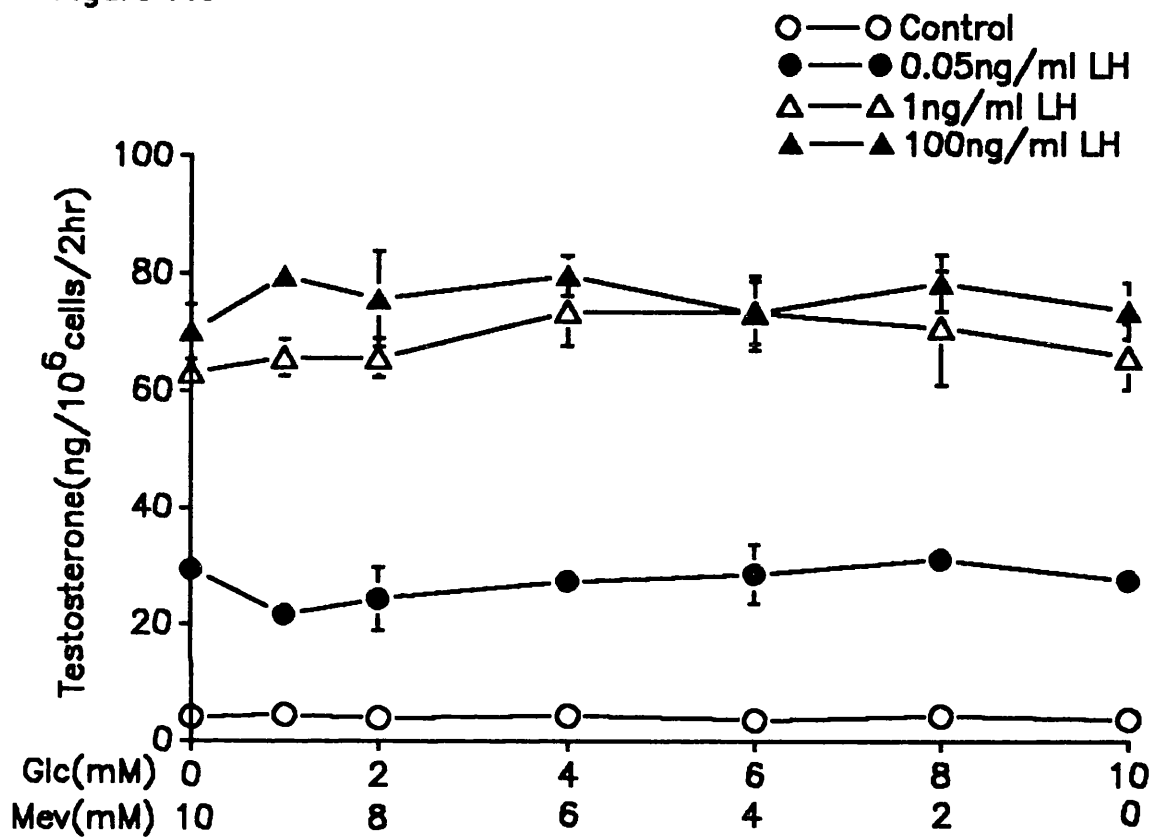
**Fig. 7.5 Effect of higher concentrations of compactin on calmidazolium-stimulated, and on the conversion of 22(R)OH-cholesterol to testosterone production.** Leydig cells ( $2 \times 10^4$  cells/ well/  $200\mu\text{l}$ ) were incubated in the presence of different concentrations of compactin, and with calmidazolium ( $4\mu\text{M}$ ) and 22(R)OH-cholesterol ( $22(\text{R})\text{OH}$ ,  $1\mu\text{M}$ ) for 2 hours. The testosterone produced was determined as described in the Methods. Each point represents the mean  $\pm$  S.E. for triplicate incubations within one experiment.

Figure 7.5



**Fig. 7.6 Effect of progressive replacement of glucose with mevalonate on LH-stimulated testosterone production.** Leydig cells ( $2 \times 10^4$  cells/ well/  $200\mu\text{l}$ ) were incubated for 2 hours with of LH in the presence different concentrations of glucose/mevalonate (total of 10mM). The testosterone produced was measured in the incubation media as described in the Methods. Each points represents the mean  $\pm$  S.E. for triplicate incubations within one of two similar experiments.

Figure 7.6



### **7.3 DISCUSSION**

These results indicate that in rat Leydig cells, the acute regulation of testosterone production is not dependent on the activity of HMG-CoA reductase. This is in contrast to earlier suggestions that de novo synthesis of cholesterol is important for acute testosterone production (Rommerts et al., 1973). This was based on the finding that in the absence of glucose in the incubation medium Leydig cells cannot produce testosterone, although it was later shown that glutamine and 3-hydroxybutyrate can replace glucose in supporting steroidogenesis (Amrolia et al., 1988). In the light of present findings, it is more probable that for acute steroidogenesis, glucose is required as an energy source rather than for providing a source of carbon-units for the biosynthesis of cholesterol for testosterone production.

In rat Leydig cells it has been shown that HMG-CoA reductase is predominately localized to the inner mitochondrial membrane (Pignataro et al., 1983). This is in contrast to tissues such as liver, where the HMG-CoA reductase is tightly bound to the endoplasmic reticulum (Bucher et al., 1960; Mitropoulos et al., 1978). The mitochondrial location of HMG-CoA reductase may indicate the involvement of other regulating factors different from those well known for the liver microsomal enzyme (Beg et al., 1973; Rodwell et al., 1976; Ingebritsen and Gibson, 1980). The lack of effect of compactin on testosterone production could be explained by inaccessibility or possible resistance to compactin of the mitochondrial HMG-CoA reductase enzyme.

The addition of mevalonate did not stimulate basal testosterone production, this suggests that the production of mevalonate is not rate-limiting for acute steroidogenesis in rat Leydig cells. The lack of effect of mevalonate could also indicate that its basal



production is sufficient to supply cholesterol for maximum steroidogenesis. Alternatively, this may indicate that the basal cholesterol pool is sufficient to support maximum LH-stimulated steroidogenesis during a 2hr incubation.

It has recently been reported that in cultured MA-10 Leydig tumour cells, the plasma membrane is probably the source of steroidogenic cholesterol. It was suggested that newly synthesized cholesterol and cholesterol derived from internal stores are transferred to the plasma membrane, where it is then subsequently internalized for steroidogenesis (Freeman, 1987; Nagy and Freeman, 1990).

Mouse Leydig cells possess stores of cholesterol in lipid droplets, but these are not evident in rat Leydig cells. In contrast to mouse Leydig cells, rat Leydig cells have up to a ten-fold lower level of testosterone production. This lower steroidogenic activity may explain the absence of lipid droplets in rat Leydig cells. However, despite these differences they may still share the same mechanism of cycling of cholesterol through the plasma membrane before being utilized for steroidogenesis, and that this plasma membrane cholesterol pool is sufficiently large to supply cholesterol for acute steroidogenesis without requiring replenishment.

The present observations give support to the above suggestions, in that acute steroidogenesis does not appear to require continuous cholesterol biosynthesis in rat Leydig cells. However, recent studies in freshly isolated mouse Leydig cells showed that newly synthesized cholesterol is used in preference to stored cholesterol for testosterone production (Hou et al., 1990). The activity HMG-CoA reductase in these cells was increased by hormone-stimulation, but this increase was blocked by aminoglutethimide, an inhibitor of the P-450<sub>sc</sub> enzyme. It was also found that lovastatin, a potent inhibitor of cholesterol synthesis, had no effect on the unstimulated and hormone-stimulated

testosterone production during a 12 hour incubation. These results show that Leydig cells possess a large pool of steroidogenic cholesterol, and the activity of HMG-CoA reductase is regulated by the utilization of cholesterol for steroidogenesis rather than through the direct action of hormone-stimulation.

The present results also demonstrate that at high concentrations of compactin, processes other than HMG-CoA reductase activity are inhibited. This is illustrated by the inhibition of the conversion of 22(R)OH-cholesterol to testosterone, which does not require the activity of HMG-CoA reductase. Also, the addition of 10mM mevalonate to the incubation medium was unable to reverse the inhibition of LH-stimulated steroidogenesis, caused by these high concentrations of compactin. It was also found that calmidazolium-stimulated testosterone production was not inhibited by compactin, this finding would argue against the stimulation of cholesterol biosynthesis as a possible action for calmidazolium.

In conclusion, these results show that acute steroidogenesis in rat Leydig cells can occur independently of the activity of compactin-sensitive HMG-CoA reductase, although recent evidence from mouse Leydig cells show that under normal circumstances newly synthesized cholesterol is preferentially used for testosterone production. In agreement with previous work the present results also demonstrate that cholesterol biosynthesis is not the rate-controlling step in LH-stimulated steroidogenesis.

## **CHAPTER EIGHT**

The Effect of Phorbol Esters and Pertussis Toxin on  
Testosterone Production

### **8.1. The role of protein kinase C in cyclic AMP-stimulated steroidogenesis**

Recent investigations in this laboratory have demonstrated that arachidonic acid can stimulate protein kinase C (PKC) activity in rat Leydig cells (see chapter 1 section 1.4.4.). These results showed that the addition of arachidonic acid to Leydig cells had different effects on LH- and dibutyryl cAMP-stimulated testosterone production depending on the time of incubation. When the cells were incubated with arachidonic acid for 3 hours together with LH or dibutyryl cAMP, there was an inhibition of testosterone production. However, when the incubation was carried out for 5 hours, both LH- and dibutyryl cAMP-stimulated testosterone production were potentiated by approximately 50 to 100% of controls.

The cause of this biphasic effect of arachidonic acid on stimulated testosterone production was not known. Although it was shown that the PKC activity in rat Leydig cell homogenates could be downregulated by a 5 hour preincubation with PMA ( $10^{-7}$ M) or arachidonic acid ( $25\mu\text{M}$ ). This suggested that the loss of PKC activity may have caused the potentiation of LH- and dibutyryl cAMP-stimulated testosterone production.

To test this hypothesis, experiments were carried out using purified rat Leydig cells preincubated with PMA (400nM) or the inactive phorbol ester PDD (400nM) for 5 hours prior to stimulation with different concentrations of dibutyryl cAMP for a further 2 hours. Figure 8.1 shows the results of these experiments.

In cells preincubated with PMA for 5 hours, there was a marked potentiation (up to 100%) of dibutyryl cAMP-stimulated testosterone production at all concentrations of dibutyryl cyclic AMP, including basal (control -  $23.7 \pm 2.4$  ng/ $10^6$ cells; PMA-treated  $44.1 \pm 3.7$  ng/ $10^6$ cells) (fig. 8.1A). However, the cells treated with PDD, the inactive

phorbol ester, there was no difference from the control (fig. 8.1B).

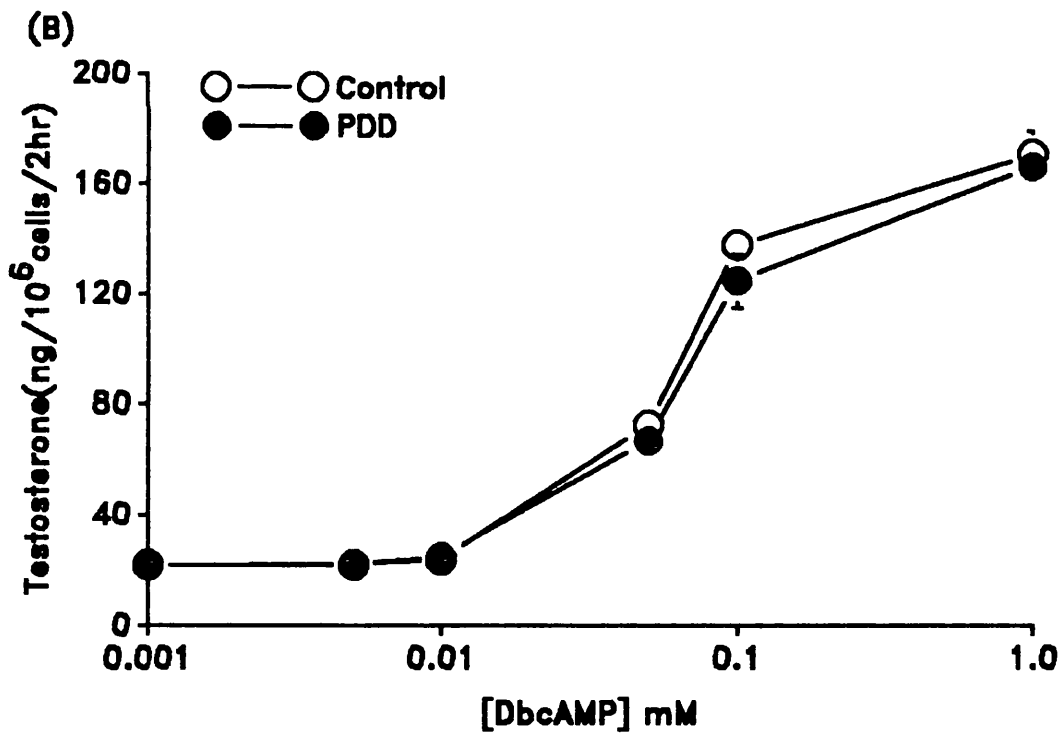
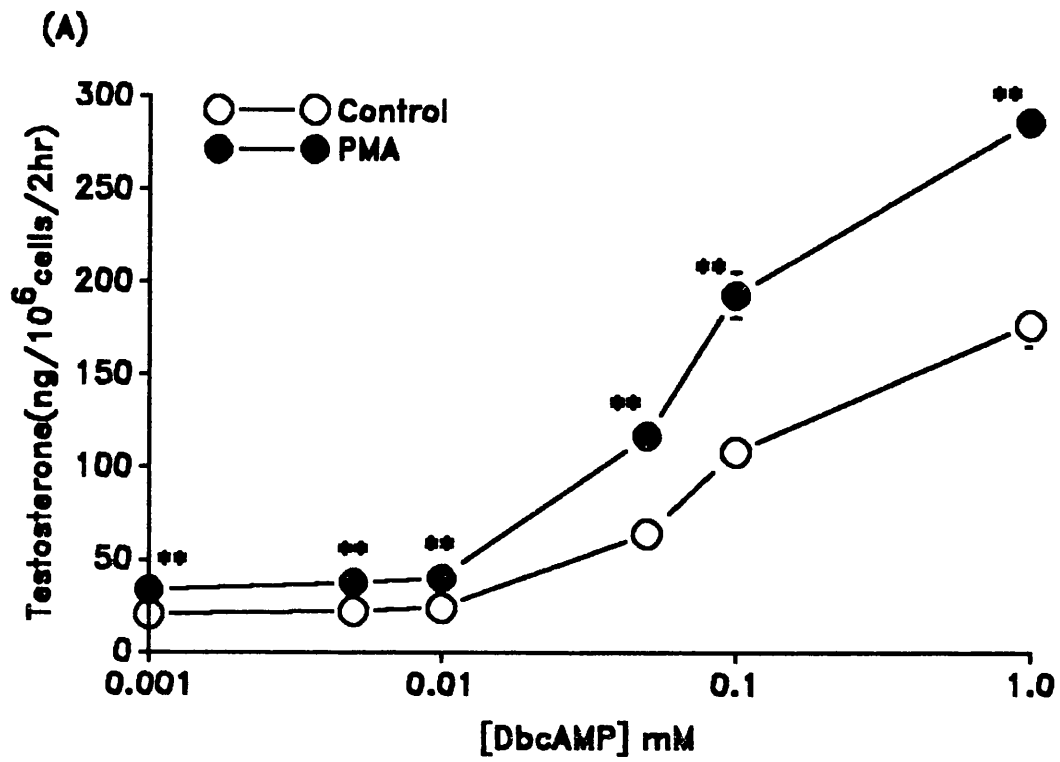
The above treatment with PMA had no effect on the conversion of 22(R)-OH-cholesterol to testosterone (control  $-128.3 \pm 29.3$  ng/ $10^6$ cells; PMA-treated  $-147.7 \pm 17.4$  ng/ $10^6$ cells). This was similarly true in cells preincubated with PDD.

Taken together these results demonstrate that cyclic AMP-stimulated steroidogenesis in rat Leydig cells is negatively regulated through the activation of PKC. The potentiation of basal testosterone production by preincubation with PMA suggests that PKC is active under basal conditions. The lack of effect of PMA on the conversion of 22(R)-OH-cholesterol to testosterone suggests the site of action of PKC to be prior to the side-chain cleavage of cholesterol to pregnenolone.

It is generally agreed that steroidogenesis is regulated through the production of short half-life proteins which stimulate the transfer of cholesterol from the outer to the inner mitochondrial membrane where side-cleavage occurs. Therefore, it is possible that PKC activity may negatively regulate the half-life or synthesis of such short half-life protein(s) that mediate the stimulatory action of LH and cyclic AMP on steroidogenesis. This would account for both the potentiation of basal and cyclic AMP-stimulated testosterone production observed when the level of PKC is downregulated by preincubation with PMA.

**Fig. 8.1 The effect of phorbol esters, PMA and PDD, on dibutyryl cyclic AMP-stimulated testosterone production.** Leydig cells ( $2 \times 10^4$  cells/ well/  $200\mu\text{l}$ ) were preincubated for 5 hours in the presence and absence of (A) PMA (400nM) and (B) PDD (400nM). These cells were then stimulated with increasing concentrations of dibutyryl cyclic AMP for a further 2 hours. The testosterone produced was measured as described in the Methods. Each point represent the mean  $\pm$  S.E. for triplicate incubations within one of two similar experiments. (\*\* P < 0.01, similar to control)

Fig. 8.1



## 8.2. The effect of pertussis toxin on LH- and dibutyryl cAMP-stimulated steroidogenesis

Previous work in this laboratory have reported the presence of a pertussis toxin sensitive G protein in rat Leydig cells (see chapter 1, section 1.4.1). It was found that the pretreatment of Leydig cells with pertussis toxin caused a potentiation of LH-stimulated cyclic AMP production. However, the effect on the production of testosterone production was not investigated.

Recent work in this laboratory have also demonstrated the release of arachidonic by LH in rat Leydig cells (see chapter 1, section 1.4.3). These investigations suggested that LH-stimulated arachidonic acid release was through the activation of phospholipase A<sub>2</sub> (PLA<sub>2</sub>) and that PLA<sub>2</sub> activity was required for the stimulation of steroidogenesis.

The LH-receptor has recently been shown to belong to the family of G protein coupled receptors (see chapter 1, section 1.2.4). This suggests that the LH receptor may stimulate PLA<sub>2</sub> through the activation of a G protein. From investigations into the G protein activation of PLA<sub>2</sub> in other cell types it has been found that the G proteins responsible were inactivated by incubation with pertussis toxin (Bokoch and Gilman, 1984; Okajima and Ui, 1984; Murayama and Ui, 1985; Burch et al., 1986).

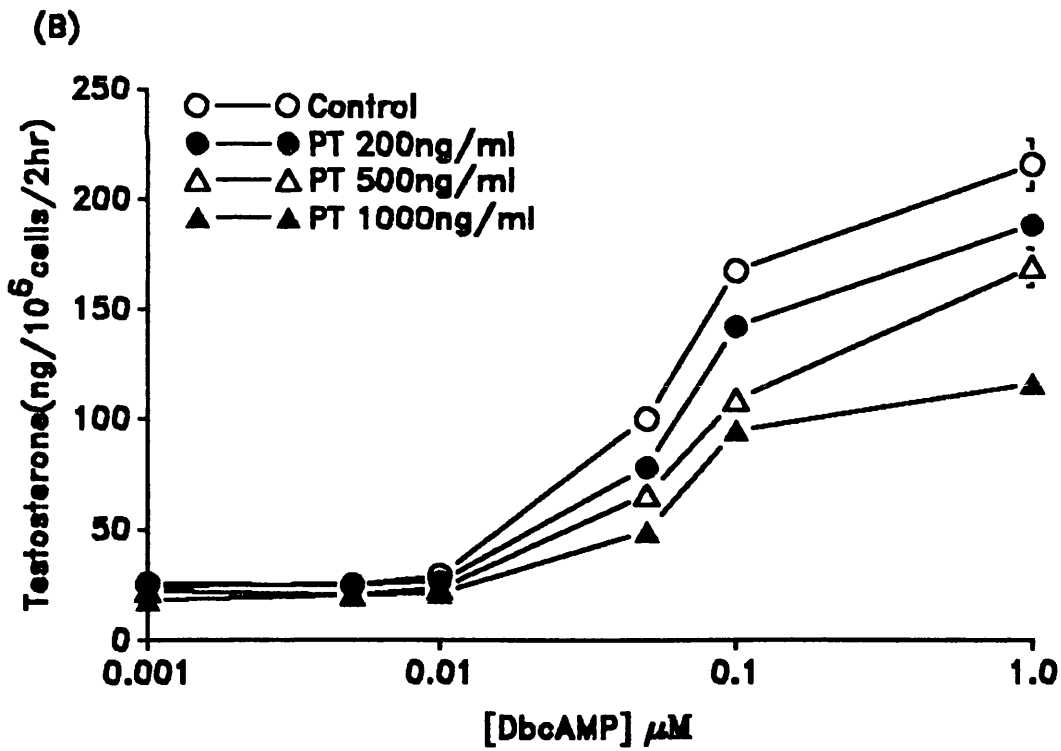
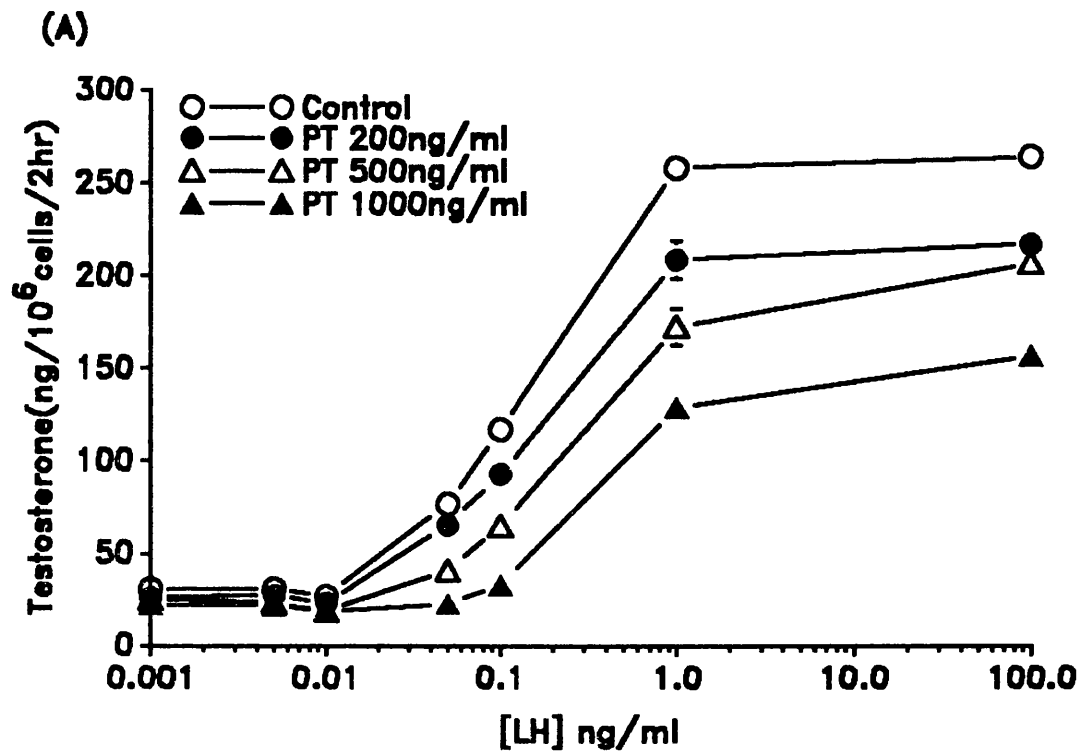
The present findings (Fig. 8.2) show that both LH- and dibutyryl cAMP-stimulated testosterone production are dose-dependently inhibited by pertussis toxin (200, 500 and 1000ng/ml). These results demonstrate that both LH- and dibutyryl cAMP- depend on pertussis toxin substrate(s) in their stimulation of testosterone production.

The inhibition of LH-stimulated testosterone production could be due to the prevention of the activation of PLA<sub>2</sub>. However, the reason for the inhibition of dibutyryl



**Fig. 8.2 Effect of pertussis toxin on LH- and dibutyryl cAMP-stimulated testosterone production.** Leydig cells ( $2 \times 10^5$  well/  $200\mu\text{l}$ ) were incubated in the absence and presence of pertussis toxin (200, 500 and 1000ng/ml) for 5 hours. These cells were then stimulated for a further 2 hours with (A) LH and (B) dibutyryl cAMP. The testosterone produced was measured in the incubation media as described in the Methods. Each point represents the mean  $\pm$  S.E. for triplicate incubations within one of two similar experiments.

Figure 8.2



cAMP-stimulated testosterone by pertussis toxin is not readily apparent. Although it is interesting to note that in previous investigations, PLA<sub>2</sub> activity has been shown to be essential for both LH- and dibutyryl cAMP-stimulated testosterone production. A possible explanation could be a basal non-receptor mediated activation of PLA<sub>2</sub> through a pertussis toxin sensitive G protein. This would account for the equal sensitivity of both LH- and dibutyryl cAMP-stimulated testosterone to pertussis toxin. Another possibility could be the involvement of a pertussis toxin sensitive G protein that is activated through phosphorylation by cyclic AMP-dependent kinase. However, such a class of G proteins has not been described (Birnbaumer et al., 1990).

## **CHAPTER NINE**

### **Summary and General Discussion**

## **9.1 Summary and General Discussion**

The previous chapters have described investigations into the regulation of steroidogenesis in purified rat Leydig cells in culture. During the course of these investigations improvements were made to the cell isolation procedure (chapter 2). Prior to these modifications the cell yield ranged between 0.5 to 1 million cells per rat. By decreasing the shaking speed and prolonging the time of incubation in collagenase, the cell yield was increased to 4 to 6 million cells per rat without loss of purity. This increase in the cell yield has significantly improved the planning of experiments.

The hypothesis formed on the basis of previous work, was that the second messenger systems used in the stimulation steroidogenesis in Leydig cells depended on the concentration of LH. It was observed that low concentrations of LH did not stimulate an increase in cAMP but was able to stimulate testosterone to near maximum levels. At these concentrations LH it was found to increase intracellular calcium (Sullivan and Cooke, 1986). At higher concentrations of LH at which cyclic AMP production was observed, this nucleotide is thought to be the second messenger for LH.

The results presented in this thesis show that calcium probably plays only a permissive role in the stimulation of testosterone in Leydig cells. Unlike in adrenal glomerulosa cells where the addition of calcium ionophore can mimic the stimulation of steroidogenesis by potassium or angiotensin II, rat Leydig cells did not show such a response; the addition of the calcium ionophore A23187 or thapsigargin, an inhibitor of the  $\text{Ca}^{2+}$ -ATPase on the endoplasmic reticulum, caused a decrease in both LH- and dibutyryl cAMP-stimulated testosterone production. Also the stimulation of an increase in intracellular calcium by LH in fura-2 loaded Leydig cells could not be readily

demonstrated. This in contrast to adrenal glomerulosa cells where potassium-or angiotensin II-stimulated increases in intracellular calcium were observed. These results argue strongly against the role of calcium as an independent second messenger mediating LH-stimulated steroidogenesis in rat Leydig cells. However it is clear that both LH- and dibutyryl cAMP-stimulated testosterone production require an optimal level of intracellular calcium, since both an increase (addition of A23187 or thapsigargin) or a decrease (removal of extracellular calcium) in intracellular calcium lead to the inhibition of LH- and dibutyryl cAMP-stimulated testosterone production.

Recent evidence has shown that even the possession of a calcium signalling system, does not necessary imply its involvement in steroidogenesis (Viard et al., 1990). These workers demonstrated the presence of functionally coupled angiotensin-II (A-II) receptors on both ovine and bovine adrenal fasciculate cells. These receptors bound A-II and showed an increase in intracellular free calcium, but only the bovine fasciculata cells responded with steroid production. Similar findings have been shown for the arginine vasopressin (AVP) receptor on rat adrenal glomerulosa and fasciculata cells, AVP stimulated steroid synthesis only in the glomerulosa cells (Gallo-Payet et al., 1986; Woodcock et al., 1986). The presence of the AVP-sensitive inositol phosphate/diacylglycerol pathway has also been found in MA-10 mouse tumour Leydig cells, but the stimulation of this signal transduction system could not be demonstrated with LH/hCG (Ascoli et al., 1989). The ability of changes in the intracellular calcium to stimulate steroidogenesis is probably determined by the specific expression of certain calcium sensitive effector elements, rather than just the possession of a calcium second messenger system. The elucidation of the factors that confer calcium responsiveness for the regulation of steroidogenesis should warrant further research.

Calmidazolium has previously been used to investigate the role of calmodulin in testosterone production (Sullivan and Cooke, 1985). In further studies using this compound, it was found that it could stimulate steroidogenesis in rat and mouse Leydig cells, and in rat adrenal cortical cells. The stimulation was found to be independent of cyclic AMP, calcium and protein synthesis. The lack of requirement for protein synthesis suggests a direct activation of steroidogenesis by this compound. The precise mechanism for its stimulation of steroidogenesis is not known.

It has been concluded that the rate-limiting step in the stimulation of steroidogenesis is the transfer of cholesterol from the outer to the inner membrane of mitochondria in steroidogenic cells. This step requires de novo protein synthesis (Ferguson, 1963; Crivello and Jefcoate, 1978). The addition of a translation inhibitor such as cycloheximide prevents the stimulation of steroidogenesis. When cycloheximide is added during trophic hormone stimulation, there is an almost immediate cessation of steroid production. The elucidation of this rate-limiting step is critical to the understanding of steroidogenesis. However, despite nearly three decades of research the details remain unknown.

The ability of calmidazolium to stimulate steroidogenesis in the absence protein synthesis may be potentially useful in dissecting the mechanisms that govern the transfer of cholesterol from the outer to the inner mitochondrial membrane.

There is very little information in the literature on the regulation of pH in steroidogenic cells. Using the fluorescent pH indicator BCECF to measure intracellular pH changes, the intracellular pH in Leydig cells was found to be 7.2, and maintained mainly by the  $\text{Na}^+/\text{H}^+$  antiporter. However, the inhibition of this antiporter using amiloride did not affect steroidogenesis in Leydig cells. This suggested that the

modulation of intracellular pH is not involved in the control of acute steroidogenesis.

The presence of outward rectifying chloride channels had previously been demonstrated in rat Leydig cells (Duchatelle and Joffre, 1987; 1990). However, the possible role of these channels in the regulation of testosterone production had not been investigated. The present findings show that the efflux of chloride ions is important in steroidogenesis, not only in Leydig cells but also in other steroidogenic cell types. The removal of extracellular chloride by equimolar exchange with gluconate salts potentiated testosterone production in LH- and dibutyryl cAMP-stimulated Leydig cells and dibutyryl cAMP-stimulated adrenal cortical cells. However, the mechanism of regulation of these chloride channels is not clear, since chloride channel inhibitors, SITS and DIDS, only inhibited LH- and not dibutyryl cAMP-stimulated testosterone production.

The inhibitory action DIDS on LH-stimulated testosterone production is probably due to the inhibition of cyclic AMP production. It was found that cholera toxin-stimulated cyclic AMP production is unaffected by DIDS. A proportion of forskolin-stimulated cyclic AMP was inhibited by DIDS, but the DIDS-insensitive portion was sufficient to give full testosterone production. Since DIDS could completely inhibit LH-stimulated cyclic AMP and testosterone production, the most probable site of action was at the LH-receptor. Therefore, it appears that the action of DIDS and the effect of extracellular chloride removal on testosterone production do not share a common mechanism.

The potentiating effect of removing extracellular chloride on steroidogenesis may reflect a fundamental property steroidogenic cells. This effect appears to be a post cyclic AMP event, and may be due to the facilitation of cholesterol transfer at the level of mitochondria. However, it is uncertain whether this represents a physiological



mechanism. It is of interest to note that recent findings demonstrate that neuroglial cells are steroidogenic (Goascogne et al., 1987; Hu et al., 1989). Another unexpected finding was the expression of GABA<sub>A</sub> receptors, similar to those found on neurones, on cultured astrocytes and oligodendrocytes. Unlike neuronal GABA<sub>A</sub> receptors which respond to GABA with an influx of Cl<sup>-</sup> ions, these glial receptors give an efflux in response to GABA (Bormann and Kettenmann, 1988). The function of these glial receptors is still speculative; it might be proposed that these receptors serve to potentiate steroidogenesis through chloride efflux. The role of neuronal steroids, especially steroid sulphates e.g. pregnenolone sulphate, has been suggested to play an important modulatory function in antagonizing the effect of GABA (Lambert et al., 1987; Majewska et al., 1986; Majewska and Schwartz, 1987). The role of steroid metabolites on the modulation of neuronal GABA<sub>A</sub>-receptor function is an active area of research, which may shed light on steroid hormone levels and mood changes e.g. premenstrual tension, and even the effects stress.

It is established that de novo synthesis of cholesterol is the major source of cholesterol for testosterone production in Leydig cells. However, the present study showed that LH-stimulated steroidogenesis was not inhibited by compactin, an inhibitor of the rate-limiting enzyme in cholesterol synthesis (HMG-CoA reductase). This conclusion has been confirmed by recent investigations in mouse Leydig cells (Hou et al., 1990), in which it was demonstrated that lovastatin, another HMG-CoA reductase inhibitor, had no effect on hCG-stimulated testosterone production during a 12 hour incubation. Taken together these results show that Leydig cells possess a large pool of steroidogenic cholesterol, and acute testosterone production is not limited through the synthesis of cholesterol.

Phorbol esters are established activators of protein kinase C (PKC) in both whole cells and cell free systems. When used at low ( $< 1\mu\text{M}$ ) concentrations, any non-specific effects can be reduced. The role of PKC in Leydig cells is not well established. Although it has been reported that it will double basal, and inhibit LH- but not dibutyryl cAMP-stimulated testosterone production (Lin, 1985; Moger, 1985; Mukhopadhyay and Schumacher, 1985; Papadopoulos et al., 1985; Nikula et al., 1987). It has also been shown to inhibit LH-stimulated cyclic AMP production. Recent results have shown that rat Leydig cells contain an isotype ( $\tau$ ) of PKC that can be activated by arachidonic acid. Further work carried out in our laboratory has confirmed this, and also shown that PKC can be down-regulated by a 5 hour preincubation with either PMA or arachidonic acid. The present findings show that the down-regulation of PKC prior to stimulation with dibutyryl cAMP, resulted in a potentiation of testosterone production. The basal production was also potentiated by preincubation of the cells with PMA. The results show that PKC negatively regulate steroidogenesis in rat Leydig cells. Since it is known that steroidogenesis is limited by the synthesis of a labile protein, and that the  $\text{cyt P}_{450\text{sc}}$  enzyme is not limiting; it could be speculated that PKC may negatively regulate the level of this labile protein. Hence, the downregulation of PKC activity potentiates both the basal and stimulated steroid production.

Pertussis toxin will ADP-ribosylate certain G proteins resulting in their inactivation. Previous work has demonstrated the presence of a pertussis toxin sensitive G protein in rat Leydig cells. The pretreatment of Leydig cells with pertussis toxin potentiated the hormone-stimulated cyclic AMP production. However, the effect of pertussis toxin on testosterone production was not investigated in those experiments. The present investigations show that both LH- and dibutyryl cAMP-stimulated testosterone production

were inhibited by pretreatment of the cells with pertussis toxin.

This finding implies that a pertussis toxin sensitive G protein is probably important to the stimulation of steroidogenesis in rat Leydig cells. It could be suggested that such a G protein is required in the activation of PLA<sub>2</sub>, which has been shown to be essential in both LH- and cyclic AMP-stimulated testosterone production. The activation of PLA<sub>2</sub> by LH is in agreement with previous studies in this laboratory, which showed that LH stimulated the release of arachidonic acid from Leydig cells prelabelled with [<sup>14</sup>C]-arachidonic acid. However, the effect of dibutyryl cAMP on the release of arachidonic acid has not been investigated. If dibutyryl cAMP was able to stimulate arachidonic acid release, the stimulation of a pertussis toxin sensitive G protein through the action of PKA would have to be proposed.

Studies in neutrophils, fibroblast and FRTL-5 thyroid cells have shown that PLA<sub>2</sub> activity can be stimulated via pertussis toxin-sensitive G-proteins (Bokoch and Gilman, 1984; Okajima and Ui, 1984; Murayama and Ui, 1985; Burch et al., 1986). However, the PLA<sub>2</sub>-specific G-protein has not been isolated, although it is possible that one of the already cloned  $\alpha_i$  molecules may be the mediator of receptor-activated PLA<sub>2</sub> (Birnbaumer et al., 1990). It has been suggested that the activation of PLA<sub>2</sub> via G-proteins could be through the binding of the  $\alpha$ -subunit-GTP to lipocortins, and thereby relieve the inhibitory effect of lipocortin on PLA<sub>2</sub> (Hirata et al., 1987). Recently, in collaboration with R. J. Flower, it was demonstrated that Leydig cells showed constitutive production of lipocortins (Phipp et al., unpublished observation).

In neutrophils and HL60 cells, three pertussis toxin-sensitive substrates have been identified,  $\alpha_{39}$ ,  $\alpha_{40}$  and  $\alpha_{41}$  (Gierschik et al., 1986, 1987). Of these,  $\alpha_{41}$  has been identified as G<sub>i</sub> and  $\alpha_{39}$  has been identified as G<sub>o</sub>, based on immunological studies.

Substrate  $\alpha_{40}$  was suggested to be the  $G_p$ , the G-protein specific for the activation of phospholipases. However, in pertussis treated HL-60 membranes, fMet-Leu-Phe stimulation of PLC could be reconstituted by the addition of highly purified rat brain pertussis toxin-sensitive  $G_o$  and  $G_i$  proteins (Kikuchi et al., 1986). These findings have implications for the potential physiological roles of the pertussis toxin-sensitive G-protein found in Leydig cells (Platts et al., 1988). The possibility exists that the LH-receptor may activate  $PLA_2$  activity through interactions with a pertussis toxin-sensitive G-protein.

Figure 9.1 summarizes the events involved in the acute stimulation of testosterone production in Leydig cells. Many aspects of this scheme remain uncertain, especially the mechanism regulating the synthesis and function of the "labile proteins" believed to be central to the stimulation steroidogenesis. Recent progress has been made in this area, in both mouse MA10 tumour Leydig cells (Stocco and Sodeman, 1991) and in rat adrenal cortical cells (Epstein and Orme-Johnson, 1991). These workers demonstrated the presence of a 37kDa protein which possess all the kinetic characteristics befitting a good candidate as the labile-protein.

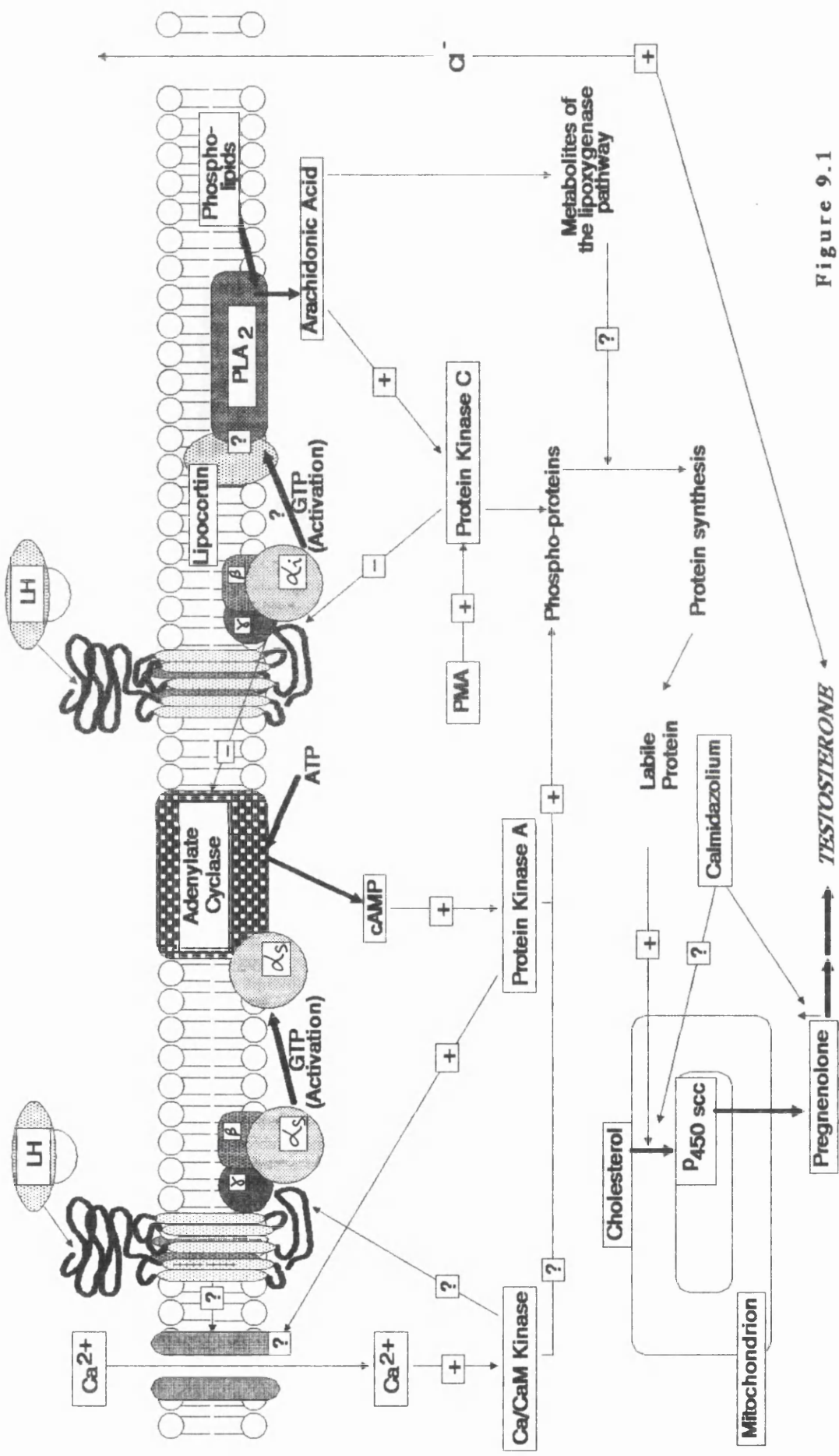


Figure 9.1

## Future work

1. The role of calcium in the regulation of steroidogenesis should be addressed, with emphasis not on the second messenger systems but on the nature of the calcium-dependent proteins mediating the calcium message. This will involve comparative studies between calcium responsive and non-calcium responsive steroid producing cells.

2. The effect of calmidazolium on isolated mitochondria requires investigation. The question whether calmidazolium can mobilize cholesterol from the outer to the inner mitochondrial membrane can be investigated using mitochondria isolated from cells stimulated in the presence of cycloheximide. The presence of cycloheximide during LH/dibutyryl cyclic AMP stimulation of Leydig cells should cause the accumulation of cholesterol in the outer mitochondrial membrane, and the addition of a range of concentrations of calmidazolium to mitochondria isolated from these cells should demonstrate whether it can stimulate the transfer of cholesterol.

3. The possible physiological role of chloride efflux in the regulation of steroidogenesis is best investigated in a system where the chloride channels are well defined, as in the case of the neuroglial cells possessing GABA<sub>A</sub>-receptors which respond to GABA with a chloride efflux.

4. The role played by protein kinase C in the regulation of steroidogenesis in Leydig cells is still unclear. Although from the work with phorbol esters it has been suggested to be involved with LH-receptor regulation at the membrane, and at site beyond cyclic AMP

production. Its role in protein phosphorylation can initially be studied through  $^{32}\text{P}$  incorporation under different conditions e.g. kinetic study of phorbol ester induced protein phosphorylation in the different cellular compartments. The possible importance of these proteins can be inferred through comparison with the phosphorylation patterns obtained after stimulation with cyclic AMP. The identification of these proteins may contribute significantly to the understanding of processes regulating steroidogenesis.

5. The effect of pertussis toxin on steroidogenesis suggest that pertussis toxin-sensitive G-proteins are involved in LH- and cyclic AMP- stimulated steroidogenesis. A possibility that is of importance to steroidogenesis is the activation of  $\text{PLA}_2$  through a pertussis toxin-sensitive G-protein. The activity of  $\text{PLA}_2$  in isolated Leydig cell plasma membranes can be investigated in the presence and absence of activated PKA with and without pertussis toxin pretreatment. This would shed light on the role of cyclic AMP in the activation of  $\text{PLA}_2$ . It has been demonstrated that LH can release  $^{14}\text{C}$ -arachidonic from Leydig cells, strongly suggesting the activation of  $\text{PLA}_2$ . These experiments could be performed with and without pertussis toxin pretreatment, and also include a cyclic AMP analogue as the stimulant. The findings would be important in establishing a role for a pertussis toxin-sensitive G-protein and  $\text{PLA}_2$  in the regulation of Leydig cell steroidogenesis. These experiments would also establish a possible source of arachidonic acid for the production of metabolites of the lipoxygenase pathway, which are thought to be essential in the stimulation of steroidogenesis.

## **BIBLIOGRAPHY**



## **BIBLIOGRAPHY**

Abayasekara, D.R.E., Band, A.M. and Cooke, B.A. (1990). *Mol. Cell. Endocrinol.* **70**, 147-153.

Abramowitz, J., Iyengar, R. and Birnbaumer, L. (1981). In *Functional Correlates of Hormone Receptors in Reproduction*. Eds. V.B. Mahesh, T.G. Muldon, B.B. Saxena, and W.A. Sadler. 335-365. Amsterdam: Elsevier.

Adam, L.A., Vician, L., Clifton, D.K. and Steiner, R.A. (1991). *Endocrinology*. **128**, 1881-1886.

Adashi, E.Y., Resnick, C.E., Cronin, M.J. and Hewlett, E.L. (1984). *Endocrinology*. **115**, 839-841.

Aguilera, G. and Catt, K.J. (1986) *Endocrinology* **118**, 112-118.

Alila, H.W., Corradino, R.A. and Hansel, W. (1989). **124**, 2314-2320.

Amrolia, P., Sullivan, M.H.F., Garside, D., Baldwin, S.A. and Cooke, B.A. (1988) *Biochem. J.* **249**, 925-928.

Amsterdam, A. and Suh, B.S. (1991). *Endocrinology*. **128**, 503-510.

Anakwe, O.O. and Payne, A.H. (1987). *Mol. Endocrinol.* **1**, 595-603.

Ascoli, M., Pignataro, O.P. and Segaloff, D.L. (1989). *J. Biol. Chem.* **264**, 6674-6681.

Bahinski, A., Nair, A.C., Greengard, P. and Gadsby, D.C. (1989) *Nature* **340**, 718-721.

Bardin, W.C., Chen, C.L.C., Morris, P.L., Gerendai, I., Boitani, C., Liotta, A.S., Margioris, A. and Krieger, D.T. (1987). *Recent Prog. Horm. Res.* **43**, 1-28.

Barrett, P.Q., Bollag, W.B., Isales, C.M., McCarthy, R.T. and Rasmussen, H. (1989) *Endocr. Rev.* **10**, 496-518.

Barrett, P.Q., Kojima, I., Kojima, K., Zawalich, K, Isales, C.M. and Rasmussen, H. (1986) *Biochem. J.* **238**, 893-903.

Beg, Z.H., Allman, D.W. and Gibson, D.M. (1973) *Biochem. Biophys. Res. Commum.* **54**, 1362-1369.

Bell, J.D. and Brunton, L.L. (1986). *J. Biol. Chem.* **261**, 12036-12041.

Berridge, M.J. and Irvine, R.F. (1984). *Nature*. **312**, 315-321.

- Berridge, M.J. (1987). *Ann. Rev. Biochem.* **56**, 159-93.
- Berthold, A.A. (1849). *Achiv für Anatomie Physiologie und Wissenschaftliche medicin.* **16**, 42-46.
- Besman, M.J., Yanagibashi, K., Lee, T.D., Kawamura, M., Hall, P.F. and Shively, J.E. (1989). *Proc. Natl. Acad. Sci. USA.* **86**, 4897-4901.
- Birnbaumer, L., Codina, J., Matteredra, R., Cerione, R.A., Hildebrandt, J.D., Sunyer, T., Rojas, F.J., Caron, M.G., Lefkowitz, R.J. and Iyengar, R. (1985) *Recent Prog. Horm. Res.* **41**, 41-99.
- Birnbaumer, L., Abramowitz, J. and Brown, A.M. (1990). *Biochim. Biophys. Acta.* **1030**, 163-224.
- Blackmore, P.F., Beebe, S.J., Danforth, D.R. and Alexander, N. (1990). **265**, *J. Biol. Chem.* 1376-1380.
- Blum, J.J. and Conn, P.M. (1982) *Proc. Natl. Acad. Sci. USA.* **79**, 7307-7311.  
Bokoch, G.M. and Gilman, A.G. (1984). *Cell.* **39**, 301-308.
- Bormann, J. and Kettenmann, H. (1988) *Proc. Natl. Acad. Sci. USA.* **85**, 9336-9340.
- Bretag, A.H. (1987) *Physiol. Rev.* **67**, 618-704.
- Bridges, R.J., Worrell, R.T., Frizzell, R.A. and Benos, D.J. (1989) *Am. J. Physiol.* **256**, 902-912.
- Brown, M.S., Faust, J.R., Goldstein, J.L., Kaneko, I. and Endo, A. (1978) *J. Biol. Chem.* **253**, 1121-1128.
- Bucher, N.L., Overath, P. and Lynen, F. (1960) *Biochim. Biophys. Acta* **40**, 491-501.
- Bunzow, J.R., Van Tol, H.H.M., Grandy, D.K., Albert, P., Salon, J., Burch, R.M., Luini, A. and Axelrod, J. (1986). *Proc. Natl. Acad. Sci. USA.* **83**, 7201-7205.
- Campbell, W.B., Brady, M.T., Rosolowsky, L.J. and Falck, J.R. (1991). **128**, 2183-2194.
- Campos, M.B., Calandra, R.S. and Ritta, M.N. (1990) 6th European Testis Workshop B5.(Abstract)
- Capponi, A.M., Lew, P.D. and Vallotton, M.B. (1987) *Biochem. J.* **247**, 335-340.
- Capponi, A.M., Lew, P.D., Jornot, L. and Vallotton, M.B. (1984) *J. Biol. Chem.* **259**, 8863-8869.

- Catt, K.J. and Dufau, M.L. (1973) *Nature New Biology* **244**, 219-221.
- Catt, K.J. and Stojilkovic, S.S. (1989). *TEM*. Sept/Oct., 15-20.
- Champigny, G., Verrier, B., Gerard, C., Mauchamp, J. and Lazdunski, M. (1990) *FEBS Letters* **259**, 263-268.
- Channing, C.P., Sakai, C.N. and Bahl, O.P. (1978). *Endocrinology*. **103**, 341-348.
- Charreau, E.H., Calvo, J.C., Nozu, K., Pignataro, O.P., Catt, K.J. and Dufau, M.L. (1981). *J. Biol. Chem.* **256**, 12719-12724.
- Chaudry, L., Schulster, D. and Cooke, B.A. (1989). *Biochem. Soc. Trans.* **17**, 752-753.
- Chen, H-C., Shimohigashi, Y., Dufau, M.L. and Catt, K.J. (1982). *J. Biol. Chem.* **253**, 7109-7114.
- Cheung, W.Y. (1980) *Science* **207**, 19-27.
- Chiou, C.Y. and Maglagodi, M.H. (1975) *Br. J. Pharmacol.* **53**, 279-285.
- Christie, M., Machida, C.A., Neve, K.A. and Civelli, O. (1988). *Nature*. **336**, 783-787.
- Chronwall, B.B. (1989). In *Neuropeptide Y*. 51-60. Eds. Mutt, V., Höfelt, T., Fuxe, K. and Lundberg, J.M. New York: Raven Press.
- Cicero, T.J., Schainker, B.A. and Meyer, E.R. (1979). *Endocrinology*. **104**, 1286-1291.
- Cicero, T.J., Meyer, E.R., Gabriel, S.M., Bell, R.D. and Wilcox, C.E. (1980). *Brain Res.* **202**, 151-164.
- Cohen, C.J., McCarthy, R.T., Barrett, P.Q. and Rasmussen, H. (1988) *Proc. Natl. Acad. Sci. USA.* **85**, 2412-2416.
- Cole, L.A., Perini, F., Birken, S. and Ruddon, R.W. (1984). *Biochem. Biophys. Res. Commun.* **122**, 1260-1267
- Colombini, M. (1979) *Nature* **279**, 643-645.
- Colombini, M. (1987) *J. Bioenerg. Biomembr.* **19**, 309-320.
- Cooke, B.A., van der Molen, H.J. and Setchell, B.P. (1973). In R. G. Edwards (Ed.), *The Testis. Research in Reproduction*, Vol. 5, no. 6. International Planned Parenthood Federation.
- Cooke, B.A., Janszen, F.H.A., Clotscher, W.F. and van der Molen, H.J. (1975). *Biochem. J.* **150**, 413-418.

- Cooke, B.A., Lindh, L.M. and Janszen, F.H.A. (1977). *FEBS Lett.* **73**, 67-71.
- Cooke, B.A., Golding, M., Dix, C.J. and Hunter, M.G. (1982). *Mol. Cell Endocrinol.* **27**, 221-232.
- Cooke, B.A. (1983). *Curr. Topics Mem. Trans.* **18**, 143-175.
- Cooke, B.A., Platts, E.A., Abayasekara, D.R.E., Kurlak, L.O., Schulster, D. and Sullivan, M.H.F. (1989). *J. Reprod. Fert., Suppl.* **37**, 139-145.
- Cooke, B.A., Abayasekara, D.R.E. and Rose, M.P. (1990). *NATO ASI Series Vol. H44.* 99-113. Eds. T.M. Konijn, M.D. Houslay and P.J.M. Van Haastert. Berlin, Heidelberg: Springer-Verlag.
- Cooke, B.A., Dirami, G., Chaudry, L., Choi, M.S.K., Abayasekara, D.R.E. and Phipp, L. (1991). *J. Steroid Biochem. Mol. Biol.* **40**, 465-471.
- Davidson, J., van der Merwe, P.A., Wakefield, I. and Millar, R.P. (1991). *Mol. Cell Endocrinol.* **76**, C33-C38.
- Davis, J.S., West, L.A., Weakland, L.L. and Farese, R.V. (1986). *FEBS Lett.* **208**, 287-291.
- Davis, J.S., Weakland, L.L., Farese, R.V. and West, L.A. (1987). *J. Biol. Chem.* **262**, 8515-8521.
- Dazord, A., Gallet de Santerre, D. and Saez, J.M. (1981). *Biochem. Biophys. Res. Commun.* **98**, 885-891.
- De Souza, E.B., Anholt, R.R.H., Murphy, K.M.M., Snyder, S.H. and Kuhar, M.J. (1985) *Endocrinology* **116**, 567-573.
- Dingledine, R., Myers, S.J. and Nicholas, R.A. (1990) *FASEB J.* **4**, 2636-2645.
- DiRosa, M., Flower, R.J., Hirata, F., Parente, L. and Russo-Marie, F. (1984). **28**, 441-442.
- Dix, C.J., Schumacher, M. and Cooke, B.A. (1982). *Biochem. J.* **202**, 739-745.
- Dix, C.J., Habberfield, A.D., Sullivan, M.H.F. and Cooke, B.A. (1984). *Biochem. J.* **219**, 529-537.
- Dix, C.J., Habberfield, A.D. and Cooke, B.A. (1987). *Biochem. J.* **243**, 373-377.

Dixon, R.A.F., Kobilka, B.K., Strader, D.J., Benovic, J.L., Dohlman, H.G., Frielle, T., Bolanowski, M.A., Bennett, C.D., Rands, E., Diehl, R.E., Mumford, R.A., Slater, E.E., Sigal, I.S., Caron, M.G., Lefkowitz, R.J. and Strader, C.D. (1986). *Nature*. **321**, 75-79.

Drouva, S.V., Epelbaum, J., Tapia-Arancibia, L., Laplante, E. and Kordon, C. (1981). *Neuroendocrinology*. **32**, 163-167.

Duchatelle, P. and Joffre, M. (1987) *FEBS Letts* **217**, 11-15.

Duchatelle, P. and Joffre, M. (1990) *J. Physiol.* **428**, 15-37.

Dufau, M.L., Baukal, A.J. and Catt, K.J. (1978). *Proc. Natl. Acad. Sci. USA*. **77**, 5837-5841.

Dufau, M.L. (1988). *Ann. Rev. Physiol.* **50**, 483-508.

Dym, M., Hadley, M.A., Djalkiew, D. and Byers, S.W. (1988). *Development and Function of the Reproductive Organs Vol.II. Sero Symposia Review 14*. Eds. M.Parvinen, I. Huhtaniemi and L.J. Pelliniemi. 113-126. Italy: Ares-Serono Symposia Via Ravenna, 8-Rome.

Eik-Nes, K.B. (1975) in *Handbook of Physiology* pp 95-115, American Physiological Society, Washington, D.C.

Endo, A. (1988) *Klin. Wschr.* **66**, 421-427.

Epstein, L.F. and Orme-Johnson, N.R. (1991) *J. Biol. Chem.* **266**, 19739-19745.

Fabrizi, A. (1990). *TEM*. Jan/Feb, 117-120.

Ferguson, J.J. (1963). *J. Biol. Chem.* **238**, 2754-2759.

Fevold, R.H., Lorence, M.C., McCarthy, J.L., Trant, J.M., Kagimoto, M., Waterman, M.R. and Mason, J.I. (1989). *Mol. Endocrinol.* **3**, 968-975.

Flower, R.J., Wood, J.N. and Parente, L. (1984). *Adv. Inflamm. Res.* **7**, 61-70.

Freeman, D.A. (1987). *J. Biol. Chem.* **262**, 13061-13068.

Freeman, D.A. (1989). *Endocrinology*. **124**, 2527-2534.

Frizzell, R.A., Rechkemmer, G. and Shoemaker, R.L. (1986) *Science* **233**, 558-560.

Gallo-Payet, N., Guillon, G., Noelle Balestre, M. and Jard, S. **119**, 1042-1047.

Ganz, M.B., Boyarsky, G., Sterzel, R.B. and Boron, W.F. (1989) *Nature* **337**, 648-651.

- Garren, L.D., Mey, R.L. and Davies, W.W. (1965). *Proc. Natl. Acad. Sci. USA.* **53**, 1443-1450.
- Gierschik, P., Falloon, J., Milligan, G., Pines, M., Gallin, J.I. and Spiegel, A. (1986). *J. Biol. Chem.* **261**, 8058-8062.
- Gierschik, P., Sidiropoulos, D., Spiegel, A. and Jakobs, K.H. (1987). *Eur. J. Biochem.* **165**, 673-679.
- Giguere, V., Lefebvre, L. and Labrie, F. (1981). *Endocrinology.* **108**, 350-352.
- Goldstein, J.L. and Brown, M.S. (1990). *Nature.* **343**, 425-430.
- Goverman, J.M., Parsons, T.F. and Pearse, J.G. (1982). *J. Biol. Chem.* **257**, 15059-15064.
- Gower, D.B. (1979). *Croom Helm Biology in Medicine Series: Steroid Hormones.* London: Croom Helm Ltd.
- Gower, D.B. (1988). In *New Comprehensive Biochemistry: Hormones and their Actions*, Vol.I, 3-25. Eds. B.A. Cooke, R.B.J. King and H.J. van der Molen. Amsterdam: Elsevier.
- Gryniewicz, G., Poenie, M. and Tsien, R.Y. (1985) *J. Biol. Chem.* **260**, 3440-3450.
- Guidotti, A., Forchetti, C.M., Corda, M.G., Konkel, D., Bennet, D.N. and Costa, E. (1983). *Proc. Natl. Acad. Sci. USA.* **80**, 3531-3535.
- Gwynne, J.T. and Strauss III, J.F. (1982). *Endocr. Rev.* **3**, 299-329.
- Haksar, A., Maudsley, D.V., Peron, F.G. and Bedigian, E. (1976) *J. Cell Biol.* **68**, 142-153.
- Hall, P.F. and Eik-Nes, K.B. (1962). *Biochim. Biophys. Acta.* **63**, 411-422.
- Hall, P.F., Osawa, S. and Mrotek, J. (1981a) *Endocrinology* **109**, 1677-1682.
- Hall, P.F., Osawa, S. and Thomasson, C.L. (1981b) *J. Cell Biol.* **90**, 402-407.
- Hall, P.F. (1985). *Recent Prog. Horm. Res.* **41**, 1-37.
- Hallam, T., Jacob, R. and Merritt, J.E. (1988) *Biochem. J.* **255**, 179-184.
- Hardy, R.N. (1981). *Endocrine Physiology. Physiological Principles in Medicine Series.* London: Edward Arnold.

Hermier, C., Combarous, Y. and Jutisz, M. (1971). *Biochim. Biophys. ACTA.* **244**, 625-633.

Hess, P., Lansman, J.B. and Tsien, R.W. (1984) *Nature* **311**, 538-544.

Hirata, F. (1981). *J. Biol. Chem.* **256**, 7730-7733.

Hirata, F. (1984). *Adv. Inflamm. Res.* **7**, 71-78.

Hirata, F., Matsuda, K., Notsu, Y., Hattori, T. and DelCarmine, R. (1984). *Proc. Natl. Acad. Sci. USA.* **81**, 4717-4721.

Hirata, F., Stracke, M.L. and Schiffmann, E. (1987). *J. Steroid Biochem.* **27**, 1053-1056.

Hökfelt, T., Tsuruo, Y., Meister, B., Melander, T., Schalling, M. and Everitt, B. (1987). In *Regulation of Ovarian and Testicular Function*. 21-46. Eds. Mahesh, V.B., Dhindsa, D.S., Anderson, E. and Kalra, S.P. New York: Plenum Press.

Horiuchi, T., Nguyen, T.T., Cragoe, E.J. and De Lean, A. (1989) *Endocrinology* **124**, 1925-1931.

Hou, J.W., Collins, D.C. and Schleicher, R.L. (1990). **127**, 2047-2055.

Howles, C. (1990). In *Clinical IVF Forum: Current Views in Assisted Reproduction*. 41-62. Eds. P.L. Matson and B.A. Lieberman. Manchester, UK: Manchester University Press.

Hu, Z.Y., Jung-Testas, I., Robel, P. and Baulieu, E.E. (1989) *Biochem. Biophys. Res. Commun.* **161**, 917-922.

Huhtaniemi, I.T. and Warren, D.W. (1990). *TEM.* Sept/Oct, 356-362.

Hunyady, L., Kayser, S., Cragoe, E.J.Jr., Balla, I., Balla, T. and Spat, A. (1988) *Am. J. Physiol.* **254**, C744-C750.

Hwang, T.C., Guggino, S.E. and Guggino, W.B. (1990) *Proc. Natl. Acad. Sci. USA.* **87**, 5706-5709.

Ingebritsen, T.S. and Gibson, D.M. (1980) in *Molecular Aspects of cellular Regulation* (Cohen, P., Ed.), pp 63-93, Elsevier/North-Holland Biomedical Press, Amsterdam.

Irvine, R.F. (1982). *Biochem. J.* **204**, 3-16.

Jackson, T.R., Blair, L.A.C., Marshall, J., Goedert, M. and Hanley, M.R. (1988). *Nature.* **335**, 437-440.

- Jackson, T.R., Patterson, S.I., Thastrup, O. and Hanley, M.R. (1988) *Biochem. J.* **253**, 81-86.
- Jakobs, K.H., Bauer, S. and Watanabe, Y. (1985). *Eur. J. Biochem.* **151**, 425-430.
- Janszen, F.H.A., Cooke, B.A., van Driel, M.J.A. and van der Molen, H.J. (1976) *Biochem. J.* **160**, 433-437.
- Johnson, A.L. and Tilly, J.L. (1990). *Biol. Reprod.* **43**, 922-928.
- Julius, D., MacDermott, A.B., Axel, R. and Jessell, T.M. (1988). **241**, 558-564.
- Kamel, F. and Krey, L.C. (1983). *Mol. Cell. Endocrinol.* **32**, 285-300.
- Kamel, F. and Kubajak, C.L. (1988). *Am. J. Physiol.* **255**, E314-E321.
- Kaplan, M.R. and Simoni, R.D. (1985). *J. Cell Biol.* **101**, 446-453.
- Kaplan, S.L., Grumbach, M.M. and Aubert, M.L. (1976). *Recent Prog. Horm. Res.* **32**, 161-243.
- Karten, M.J. and Rivier, J.E. (1986). *Endocr. Rev.* **7**, 44-55.
- Katada, T., Gilman, A.G., Watanabe, Y., Bauer, S. and Jakobs, K.H. (1985). *Eur. J. Biochem.* **151**, 431-437.
- Keinanen, K.P. and Rajaniemi, H.J. (1986). *Biochem. J.* **239**, 83-87.
- Kikuchi, A., Kozawa, O., Kaibuchi, K., Katada, T., Ui, M. and Takai, Y. (1986). *J. Biol. Chem.* **261**, 11558-11562.
- Klee, C.B. and Vanaman, T.C. (1982) *Adv. Protein. Chem.* **35**, 213-303.
- Knudsen, J., Hoirup, P., Hansen, H.O., Hansen, H.F. and Roepstorff, P. (1989). *Biochem. J.* **265**, 13-19.
- Kobilka, B.K., Matsui, H., Kobilka, T.S., Yang-Feng, T.L., Francke, U., Caron, M.G., Lefkowitz, R.J. and Ragan, J.W. (1987). *Science.* **238**, 650-656.
- Kobilka, B.K., Kobilka, T.S., Daniel, K., Regan, J.W., Caron, M.G. and Lefkowitz, R.J. (1988). *Science.* **240**, 1310-1316.
- Kojima, I., Kojima, K. and Rasmussen, H. (1985). *Endocrinology.* **117**, 1057-1066.
- Kojima, I., Kojima, K. and Rasmussen, H. (1985) *J. Biol. Chem.* **260**, 9177-9184.
- Koo, Y.B., Ji, I., Slaughter, R.G. and Ji, T.H. (1991). *Endocrinology.* **128**, 2297-2308.



- Krall, J.F. and Jamgotchian, N. (1987) *Biochem. J.* **241**, 463-467.
- Krueger, R.J. and Orme-Johnson, N.R. (1988). *Endocrinology.* **122**, 1869-1875.
- Krulwich, T.A. (1983) *Biochim. Biophys. Acta* **726**, 245-264.
- Kubo, T., Fukuda, K., Mikami, A., Maeda, A., Takahashi, H., Mishina, M., Haga, T., Haga, K., Ichiyama, A., Kangawa, K., Kojima, M., Matsuo, H., Hirose, T. and Numa, S. (1986). *Nature.* **323**, 411-416.
- Lambert, J.J., Peters, J.A. and Cottrell, G.A. (1987). *TIPS.* **8**, 224-227.
- Le Goascogn, C., Robel, P., Gouézou, M., Sananès, N., Baulieu, E.E., and Waterman, M. (1987) *Science* **237**, 1212-1215.
- Lefkowitz, R.J. and Caron, M.G. (1988). *Recent Prog. Horm. Res.* **43**, 469-497.
- Libert, F., Lefort, A., Gerard, C., Parmentier, M., Perret, J., Ludgate, M., Dumont, J.E. and Vassart, G. (1989). *Biochem. Biophys. Res. commun.* **5**, 1250-1255.
- Lin, T., Murono, E., Osterman, J., Troen, P. and Nankin, H.R. (1979) *Int. J. Androl.* **2**, 549-558.
- Lin, T., Murono, E., Osterman, J. and Nankin, H. (1980) *Biochim. Biophys. Acta* **627**, 157-164.
- Lin, T. (1985). *Endocrinology.* **117**, 119-126.
- Loosfelt, H., Misrahi, M., Atger, M., Salesse, R., Vu Hai-Luu Tai, M.T., Jolivet, A., Guiochon-Mantel, A., Sar, S., Jallal, B., Garnier, J. and Milgrom, E. (1989). *Science.* **245**, 525-528.
- Lopez-Ruiz, M.P., Choi, M.S.K., Rose, M.P., West, A.P. and Cooke, B.A. (1992). *Endocrinology.* **130**, 1122-1130.
- Luskey, K.L. (1988). *Recent Prog. Horm. Res.* **44**, 35-51.
- Lynch, A.M., Meats, J.E., Best, L. and Tomlinson, S. (1989) *Biochim. Biophys. Acta* **1012**, 166-170.
- Maddocks, S. and Sharpe, R.M. (1989). *J. Endocrinol.* **122**, 323-329.
- Madshus, I.H. (1988) *Biochem. J.* **250**, 1-8.
- Majercik, M.H. and Puett, D. (1991). *Mol. Cell Endocrinol.* **75**, 247-256.

- Majewska, M.D., Harrison, N.L., Schwartz, R.D., Barker, J.L. and Paul, S.M. (1986) *Science* **232**, 1004-1007.
- Majewska, M.D. and Schwartz, R.D. (1987) *Brain Res.* **404**, 355-360.
- Manjunath, P. and Sairam, M.R. (1982). *J. Biol. Chem.* **257**, 7109-7115.
- Magner, J.A. and Weintraub, B.D. (1982). *J. Biol. Chem.* **257**, 6709-6715.
- Mannella, C.A. and Tedeschi, H. (1987) *J. Bioenerg. Biomembr.* **19**, 305-308.
- Marquardt, H., Todaro, G.J. and Shoyab, M. (1986). *J. Biol. Chem.* **261**, 9727-9731.
- Masu, Y., Nakayama, K., Tamaki, H., Harada, Y., Kuno, M. and Nakanishi, S. (1987). *Nature.* **329**, 836-838.
- McFarland, K.C., Sprengel, R., Phillips, H.S., Kohler, M., Rosemblyt, N., Nikolics, K., Segaloff, D.L. and Seeburg, P.H. (1989). *Science* **245**, 494-499.
- Mertz, L.M. and Pedersen, R.C. (1989). *J. Biol. Chem.* **264**, 15274-15279.
- Mendelson, C., Dufau, M. and Catt, K.J. (1975) *J. Biol. Chem.* **250**, 8818-8823.
- Minegishi, T., Nakamura, K., Takakura, Y., Miyamoto, K., Hasegawa, Y., Ibuki, Y. and Igarashi, M. (1990). *Biochem. Biophys. Res. Commun.* **172**, 1049-1054.
- Misrahi, M., Loosfelt, H., Atger, M., Sar, S., Guiochon-Mantel, A. and Milgrom, E. (1990). *Biochem. Biophys. Res. Commun.* **166**, 394-403.
- Mitropoulos, K.A., Venkatesan, S., Balasubramaniam, S. and Peters, T.J. (1978) *Eur. J. Biochem.* **82**, 419-429.
- Moyle, W.R., Moudgal, M.R. and Greep, R.O. (1971) *J. Biol. Chem.* **246**, 4978-4982.
- Moyle, W.R. and Ramachandran, J. (1973) *Endocrinology* **93**, 127-134.
- Moger, W.H. (1983) *Biol. Reprod.* **23**, 528-535.
- Moger, W.H. (1985). *Life Sci.* **37**, 869-873.
- Morris, M.D. and Chaikoff, I.L. (1959). *J. Biol. Chem.* **234**, 1095-1097.
- Moyle, W.R., Moudgal, M.R. and Greep, R.O. (1971). *J. Biol. Chem.* **246**, 4978-4982.
- Muhkin, A.G., Papadopoulos, V., Costa, E. and Krueger, K.E. (1989). *Proc. Natl. Acad. Sci. USA.* **86**, 9813-9816.

- Mukhopadhyay, A.K. and Schumacher, M. (1985). *FEBS Lett.* **187**, 56-60.
- Mukhopadhyay, A.K., Kistler, M. and Dasselar, J. (1985). *Acta Endocrinol.* **108** (suppl.), 94-95.
- Mulchahey, J.J., DiBlasio, A.M., Martin, M.C., Blumenfeld, Z. and Jaffe, R.B. (1987). *Endocr. rev.* **8**, 406-425.
- Murayama, T. and Ui, M. (1985). *J. Biol. Chem.* **260**, 7226-7233.
- Nadler, J.L., Natarajan, R. and Stern, N. (1987). *J. Clin. Invest.* **80**, 1763-1769.
- Nagy, L. and Freeman, D.A. (1990). *Endocrinology.* **126**, 2267-2276.
- Nagayama, Y., Kaufman, K.D., Seto, P. and Rapoport, B. (1989). *Biochem. Biophys. Res. Commun.* **165**, 1184-1190.
- Nakanishi, M., Goldstein, J.L. and Brown, M.S. (1988) *J. Biol. Chem.* **263**, 8929-8937.
- Nakayama, N., Miyajima, A. and Arai, K. (1985). *EMBO J.* **4**, 2643-2648.
- Naor, Z., Shearman, M.S., Kishimoto, A. and Nishizuka, Y. (1988). *Mol. Endocrinol.* **2**, 1043-1048.
- Nathans, J. and Hogness, D.S. (1983). *Cell.* **34**, 807-814.
- Nikula, H., Naor, Z., Parvinen, M. and Huhtaniemi, I. (1987). *Mol. Cell. Endocrinol.* **49**, 39-49.
- Nilsson, B., Rosen, S.W., Weintraub, B.D. and Zopf, D.A. (1986). *Endocrinology.* **119**, 2723-2743.
- Nishizuka, Y. (1988). *Nature (London).* **334**, 661-665.
- O'Dowd B.F., Lefkowitz, R.J. and Caron, M.G. (1989). *Ann. Rev. Neurosci.* **12**, 67-83.
- Okajima, F. and Ui, M. (1984). *J. Biol. Chem.* **259**, 13863-13871.
- Pain-Smith, M.C.M., Yada, T., Yaney, G.C., Abdel El Motel, S.M.A., Wiedenkiller, D.E. and Sharp, G.W.G. (1988) *Endocrinology* **123**, 1984-1991.
- Papadopoulos, V., Carreau, S. and Drosdowsky, M.A. (1985). *FEBS Lett.* 312-316.
- Papadopoulos, V., Mukhin, A.G., Costa, E. and Krueger, K.E. (1990) *J. Biol. Chem.* **265**, 3772-3779.

- Papadopoulos, V., Widmaier, E.P. and Hall, P.F. (1990) *Endocrinology* **126**, 2465-2473.
- Papadopoulos, V., Nowzari, F.B. and Krueger, K.E. (1991). *J. Biol. Chem.* **266**, 3682-3687.
- Parsons, T.F., Bloomfield, G.A. and Pierce, J.G. (1983). *J. Biol. Chem.* **258**, 240-244.
- Parsons, T.F., Strickland, T.W. and Pierce, J.G. (1985). *Methods in Enzymology, Hormone Action, Part I.* 736-749. Eds. Birnbaumer, L. and O'Mally, B.W. London: Academic Press.
- Parmentier, M., Libert, F., Maenhaut, C., Lefort, A., Gerard, C., Perret, J., Van Sande, J., Dumont, J.E. and Vassart, G. (1989). *Science*, **246**, 1620-1622.
- Payne, A.H. (1990). *Biol. Reprod.* **42**, 399-404.
- Pedersen, R.C. and Brownie, A.C. (1987). **236**, 188-190.
- Pelosin, F.M., Ricouart, A., Sergheraet, C.H. Benahmed, M. and Chambaz, E.M. (1991). *Mol. Cell Endocrinol.* **75**, 149-155.
- Pierce, J.G. and Parsons, T.F. (1981). *Ann. Rev. Biochem.* **50**, 465-495.
- Pignataro, O.P., Radicella, J.P., Calvo, J.C. and Charreau, E.H. (1983) *Mol. Cell. Endocrinol.* **33**, 53-67.
- Plant, T.M. and Dubey, A.K. (1984). *Endocrinology.* **115**, 2145-2153.
- Platts, E.A., Cooke, B.A. and Schulster, D. (1986) *Biochem. Soc. Trans.* **15 abs 116**,
- Platts, E.A., Schulster, D. and Cooke, B.A. (1988). *Biochem. J.* **253**, 895-899.
- Pon, L., Epstein, L.F. and Orme-Johnson, N.R. (1986a). *Endocr. Res.* **12**, 429-446.
- Pon, L., Hartigan, J.A. and Orme-Johnson, N.R. (1986b). *J. Biol. Chem.* **261**, 13309-13316.
- Privalle, C.T., Crivello, J.F. and Jefcoate, C.R. (1983). *Proc. Natl. Acad. Sci. USA.* **80**, 702-706.
- Putney, J.W.Jr. (1987). *Am. J. Physiol.* **252**, G149-G157.
- Quinton, P.M. (1990) *FASEB J.* **4**, 2709-2717.
- Ray, D.B., Horst, I.A and Kowal, J. (1980). *Proc. Natl. Acad. Sci. USA.* **77**, 4684-4652.

- Reiter, R.J. (1991). TEM. Jan/Feb, 13-19.
- Ritta, N.N., Campos, M.B. and Calandra, R. (1987) Life Science **40**, 791-797.
- Rivier, C., Meunier, H., Roberts, V. and Vale, W. (1990). Recent Prog. Hormon. Res. **46**, 231-259.
- Rodwell, V.W., Nordstrom, J.L. and Mitschelen, J.J. (1976) in Advances in Lipid Research (Paoletti, R. and Kritchevsky, D., Eds.), pp 1-74, Academic Press, New York.
- Rommerts, F.F.G., Cooke, B.A., Van der Kemp, J.C.M. and Van der Molen, H.J. (1973) FEBS Lett. **33**, 114-118.
- Rommerts, F.F.G. and Cooke, B.A. (1988). In New Comprehensive Biochemistry: Hormones and their Actions, Vol.II, 163-180. Eds. B.A. Cooke, R.B.J. King and H.J. van der Molen. Amsterdam: Elsevier.
- Roufogalis, B.D. (1985) in Calcium and Cell Physiology (Marne, D., Ed.), pp 148-169, Springer-Verlag, Berlin
- Sagi-Eisenberg, R. (1989). TIBS. **14**, 355-357.
- Sairam, M.R. and Manjunath, P. (1983). J. Biol. Chem. **258**, 445-449.
- Sar, M., Lubahn, D.B., French, F.S. and Wilson, E.M. (1990). **127**, 3180-3186.
- Seamon, K.B. and Daly, J.W. (1981) J. Cyc. Nucl. Res. **7**, 201-224.
- Segal, J. (1989) Mol. Cell. Endocrinol. **64**, 95-103.
- Schlaepfer, D.D. and Haigler, H.T. (1988). Biochemistry. **27**, 4253-4258.
- Schoumacher, R.A., Shoemaker, R.L., Halm, D.R., Tallant, E.A., Wallace, R.W. and Frizzell, R.A. (1987) Nature **330**, 752-754.
- Schumacher, M., Schwarz, M. and Brändle, W. (1984). Mol Cell Endocrinol. **34**, 67-80.
- Schumaker, K.S. and Sze, H. (1987) J. Biol. Chem. **262**, 3944.
- Schulster, D., Burstein, S. and Cooke, B.A. (1976). Molecular Endocrinology of the Steroid Hormones. U.K.: John Wiley and Sons Ltd.
- Schwanzel-Fukuda, M. and Pfaff, D.W. (1989). Nature. **338**, 161-164.
- Segaloff, D.L., Sprengel, R., Nikolics, K. and Ascoli, M. (1990). Recent prog. Hormon. Res. **46**, 261-303.

Setchell, B.P. (1983). Benchmark papers in human physiology series, number 17. New York: Van Nostrand Reinhold Company.

Sharpe, R.M. (1990). *Clin. Endocrinol.* **33**, 787-807.

Shearman, M.S., Naor, Z., Sekiguchi, K., Kishimoto, A. and Nishizuka, Y. (1989). *FEBS Lett.* **243**, 177-182.

Shigemoto, R., Yokoda, Y., Tsucjida, K. and Nakaishi, S. (1989). *J. Biol. Chem.* **265**, 623-628.

Shin, S.I. (1967). *Endocrinology.* **81**, 440-448.

Shoyab, M., Gentry, L.E., Marquardt, H. and Todaro, G.J. (1986). *J. Biol. Chem.* **261**, 11968-11973.

Silman, R. (1991). *J. Endocrinol.* **128**, 7-11

Silverman, A-J. and Gibson, M. (1990). *TEM.* Nov/Dec, 403-407.

Simchowicz, L. and Cragoe, E.J.Jr. (1988) *Am. J. Physiol.* **254**, C150-C164.

Simpson, E.R. (1979). *Mol. Cell. Endocrinol.* **13**, 213-227.

Simpson, E.R. and Waterman, M.R. (1988). *Ann. Rev. Physiol.* **50**, 427-440.

Skinner, M.K. (1991). *Endocr. Rev.* **12**, 45-77.

Smith, M.A. and Vale, W.W. (1981). *Endocrinology.* **108**, 752-759.

Smith, W.L. (1989). *Biochem. J.* **259**, 315-324.

Snyder, S.H., Verma, A. and Trifiletti, R.R. (1987) *FASEB J.* **1**, 282-288.

Sobieszek, A. (1989) *Biochem. J.* **262**, 215-223.

Solano, A.R. Dada, L. and Podesta, E.J. (1988). *J. Mol. Endocrinol.* **1**, 147-154.

Sprengel, R., Braun, T., Nikolics, K., Segaloff, D.L. and Seegurg, P.H. (1990). *Mol. Endocrinol.* **4**, 525-530.

Stengel, D., Guenet, L., Desmier, M., Insel, P. and Hanoune, J. (1982) *Mol. Cell. Endocrinol.* **28**, 681-690.

Stocco, D.M. and Kilgore, M.W. (1988). *Biochem. J.* **249**, 95-103.

Stocco, D.M. and Chen, W. (1991). *Endocrinology.* **128**, 1918-1926.

- Stocco, D.M. and Sodeman, T.C. (1991) *J. Biol. Chem.* **266**, 19731-19738.
- Stojkovic, S.S., Rojas, E., Stutzin, A. and Catt, K.J. (1989). *J. Biol. Chem.* **264**, 10939-10942.
- Strader, C.D., Sigal, I.S. and Dixon, R.A. (1989). *FASEB J.* **3**, 1825-1832.
- Strickland, T.W., Parsons, T.F. and Pierce, J.G. (1985). In *Luteinizing Hormone Action and Receptors*. 1-15. Ed. Ascoli, M. Boca Raton, FL: CRC Press.
- Strott, C.A. (1990). *TEM*. July/Aug., 312-314.
- Sullivan, M.H.F. and Cooke, B.A. (1984). *Mol. Cell Endocrinol.* **34**, 17-22.
- Sullivan, M.H.F. and Cooke, B.A. (1985) *Biochem. J.* **232**, 55-59.
- Sullivan, M.H.F. and Cooke, B.A. (1986) *Biochem. J.* **236**, 45-51.
- Takemura, H., Thastrup, O. and Putney Jr.J.W. (1990) *Cell Calcium* **11**, 11-17.
- Tang, L.K., Martellock, A.C. and Horiuchi, J.K. (1982). *Am. J. Physiol.* **242**, E392-E397.
- Taylor, C.W. (1990). *Biochem. J.* **272**, 1-13.
- Tedeschi, H. and Kinnally, K.W. (1987) *J. Bioenerg. Biomembr.* **19**, 321-327.
- Thastrup, O., Cullen, P.J., Drobak, B.K., Hanley, M.R. and Dawson, A.P. (1990) *Proc. Natl. Acad. Sci. USA.* **87**, 2466-2470.
- Themmen, A.P.N., Hoogerbrugge, J.W., Rommerts, F.F.G. and Van der Molen, H.J. (1986). *FEBS Lett.* **203**, 116-120.
- Thomas, R.C. (1989) *Nature* **337**, 601.
- Tsai-Morris, C.H., Buczko, E., Wang, W. and Dufau, M.L. (1990). *J. Biol. Chem.* **265**, 19385-19388.
- Tolkovsky, A.M. and Richards, C.D. (1987) *Neuroscience* **22**, 1093-1102.
- Tsang, B.H. and Carnegie, J.A. (1983) *Endocrinology* **113**, 763-769.
- Tsien, R.Y., Pozzan, T. and Rink, T.J. (1982) *J. Cell Biol.* **94**, 325-334.
- Best, L., Bone, E.A., Meats, J.E. and Tomlinson, S. (1988) *J. Mol. Endocr.* **1**, 33-38.

Vahouny, G.V., Chanderbhan, R., Noland, B.J., Irwin, D., Dennis, P., Lambeth, J.D. and Scallen, T.J. (1983). *J. Biol. Chem.* **258**, 11713-11737.

Vahouny, G.V., Dennis, P., Chanderbhan, R., Fiskum, G., Noland, B.J. and Scallen, T.J. (1984). *Biochim. Biophys. ACTA.* **122**, 509-515.

Van Belle, H. (1981) *Cell Calcium* **2**, 483-494.

Varticovski, L., Chahwala, S.B., Whitman, M., Cantly, L., Schindler, D., Chow, E.P., Sinclair, L.K. and Pepinsky, R.B. (1988) *Biochemistry.* **27**, 3686-3690.

Viard, I., Rainey, W.E., Capponi, A.M., Begeot, M. and Saez, J.M. (1990). **127**, 2071-2078.

Virmani, M.A., Stojilkovic, S.S. and Catt, K.J. (1990) *Endocrinology* **126**, 2499-2505.

Wang, J.H., Pallen, C., Sharma, R.K., Adachi, A.M. and Adachi, K. (1985) *Curr. Top. Cell. Regul.* **27**, 419-436.

Wang, H., Segal, S.J. and Koide, S.S. (1989). *Mol. Cell Endocrinol.* **62**, 13-22.

Wang, H., Segaloff, D.L. and Ascoli, M. (1991). *Endocrinology.* **128**, 2651-2653.

Weiss, G.B. (1974) *Annu. Rev. Pharmacol.* **14**, 343-354.

Welsh, M.J. (1990) *FASEB J.* **4**, 2718-2725.

Wiebe, J.P., Tilbe, K.S. and Buckingham, K.D. (1980) *Steroids* **35**, 561-577.

Wierman, M.E., Gharib, S.D. and Chin, W.W. (1988). *Bailliere's Clin. Endocrinol. Metab.* **2**, 869-889.

Wilson, J.X., Aguilera, G. and Catt, K.J. (1984) *Endocrinology* **115**, 1357-1363.

Wolfe, L.S. (1982) *J. Neurochem.* **38**, 1-14.

Woodcock, E.A., Mcleod, J.K. and Johnston, C.I. (1986). *Endocrinology.* **118**, 2432-2436.

Xie, Y.B., Wang, H. and Segaloff, D.L. (1990). *J. Biol. Chem.* **265**, 21411-21414.

Yanagibashi, K., Ohno, Y., Kawamura, M. and Hall, P.F. (1988). *Endocrinology.* **123**, 2075-2082.

Yanagibashi, K., Papadopoulos, V., Masaki, E., Iwaki, T., Kawamura, M. and Hall, P.F. (1989) *Endocrinology* **124**, 2383-2391.

Yanagibashi, K., Ohno, Y., Nakamichi, N., Matsui, T., Hayashida, K., Takamura, M.,



Yamada, K., Tuo, S. and Kawamura, M. (1989). *J. Biochem.* **106**, 1026-1029.

Yanase, T., Simpson, E.R. and Waterman, M.R. (1991). *Endocr. Rev.* **12**, 91-108.

Yokoda, Y., Sasai, Y., Tanaka, K., Fujiwara, T., Tsuchida, K., Shigemo, R., Kakizuka, A., Ohkubo, H. and Nakanishi, S. (1989). *J. Biol. Chem.* **264**, 17649-17652.

MEDICAL LIBRARY.  
ROYAL FREE HOSPITAL  
HAMPSTEAD

## Publications

M.S.K. Choi and B.A. Cooke (1990). Evidence for two independent pathways in the stimulation of steroidogenesis by luteinizing hormone involving chloride channels and cyclic AMP. *FEBS Lett.* **261**, 402-404.

B.A. Cooke., G. Dirami., L. Chaudry., M.S.K. Choi., D.R.E. Abayasekara and L. Phipp (1991). Release of arachidonic acid and the effects of corticosteroids on steroidogenesis in rat Leydig cells. *J. Steroid Biochem. Molec. Biol.* **40**, 465-471.

M.S.K. Choi and B.A. Cooke (1992). Calmidazolium is a potent stimulator of steroidogenesis via mechanisms not involving cyclic AMP, calcium or protein synthesis. *Biochem. J.* **281**, 291-296.

M.P. Lopez-Ruiz., M.S.K. Choi., M.P. Rose., A.P. West and B.A. Cooke (1992). Direct effect of arachidonic acid on protein kinase C and LH-stimulated steroidogenesis in rat Leydig cells; Evidence for tonic inhibitory control of steroidogenesis by protein kinase C. *Endocrinology* **130**, 1122-1130.