

PROCEEDINGS

**Estonian Academy of Arts
Faculty of Architecture**

SPACE AND DIGITAL REALITY:
IDEAS, REPRESENTATIONS/
APPLICATIONS AND FABRICATION

10/2020

FRESH FROM THE FOREST: RAW, DISCRETE AND FULLY AUTOMATED

Gilles Retsin
Bartlett School of Architecture,
University College London¹

Abstract

Emerging new platforms combine timber with automation, prefabrication and end-to-end integration in an attempt to disrupt the construction industry. While these efforts contribute to the renewal of an often outdated industry and have the potential to contribute to a more ecologically responsible built environment, there are also a number of potential risks attached to their centralised approach to automation. Although architecture has a long history of engagement with digital technologies, it has yet to fully understand and theorise the rapid changes implied by automation and the digital economy which underlie these new platforms. This paper proposes to shift from the notions of "digital design" and "digital fabrication" to the notion of automation, to emphasise the social, political and economic implications of digital technologies. A framework of automation moreover allows us to connect with aspects of the digital economy, which is arguably the aspect of the digital that most significantly impacts the world and our cities. On an architectural level, it draws a historic continuity with mechanisation, bypassing postmodernism and the early digital's dialectic relation with the modernist project.

The work presented in this paper acknowledges the new timber platforms argument for timber as a material with disruptive capacities. Timber currently already has a high degree of automation throughout its entire production chain. Forests are managed digitally, continuously responding to the global demands and logistics of sustainable timber production. However, the paper proposes an alternative, distributed and more open-ended framework for timber platforms, based on the combination of discrete architectural parts with automation. This so-called discrete paradigm builds on a computational understanding of parts as function agnostic, serialised building blocks that can be digitally assembled into functional buildings. These building blocks are manufactured by the computer-controlled processing of widely available, two-dimensional base materials such as plywood or mass-timber sheets. Projects such as the Tallinn Architecture Biennale Installation (2017) and the Nuremberg Concert Hall (2018) explore this context of automated discrete timber and its architectural, technical and economic consequences for the production of housing and the building industry at large.

Keywords: automation, computation, digital economy, platforms, housing, robotics, timber

¹ Correspondence: g.retsin@ucl.ac.uk

1. Introduction

1.1 The 90s

Whereas architects initially speculated on the digital as something merely virtual, today, even the most banal aspects of our lives are reconfigured by digital platforms. Arguably, one of the driving forces behind this proliferation of digital technology is automation. In continuation with 19th century industrialisation and 20th century mechanisation, automation is driven by the economic desire for ever more efficient modes of production (Noble 1984). Just as with industrialisation, automation is therefore deeply connected to social, political and economic questions (Noble 1984). The futuristic Kiva robots in the Amazon warehouse cannot be understood in isolation from the gig-worker on a precarious zero-hours contract. Post-Capitalism, Post-Work society, and Universal Basic Income are all responses triggered by the ever-increasing impact of automation on our daily lives. In the early 20th century, mechanisation and new means of production were actively debated in architecture and art, from Walter Benjamin's *Art in the Age of Mechanical Reproduction* (1935) to Siegfried Giedion's *Mechanisation takes Command* (1948) and Le Corbusier's *Towards a New Architecture* (1927), and so is the political philosophy of accelerationism today in art discourse (Beech 2019). However, in architecture, emerging digital technologies were initially – in the last two decades at least – not considered as "means of production". From the nineties onwards, digital technologies provoked an incredible exploration of new notions of space and aesthetics, but were rarely inscribed in an economic or social context. In hindsight, we could speculate on the why and how of this limited reading. One explanation could be the frenzied economic climate preceding the 2008 financial crash. Perhaps a less charged account could argue that digital technologies before the 2008 financial crisis were still relatively disconnected from large economic issues. Sure, there was a dot-com bubble, but there was not yet a substantial "digital economy" – at least not acting in the built environment. Moreover, in the absence of the yet-to-emerge platform economics, social media and smartphones, the digital was not yet as pervasive as today.

1.2 Post-2008

The economic optimism of the late nineties was abruptly shelved with the financial crash of 2008. Along with it, the early digital architecture experiment was partially put into administration and evacuated from the cultural scene to academic research programmes, where they went on to be highly successful, but relatively isolated from larger discussions. Ironically, architecture's partial retreat from the digital coincided with the boom of the digital economy, social media and the explosive global dominance of Big Tech. By the time that unicorns were no longer just legendary creatures but also billion-dollar-valued startups, architectural discourse had either completely isolated itself from the digital or not developed beyond the discursive boundaries initialised before the crisis. Today, digital platforms such as Airbnb are actively reconfiguring our cities and mode of living, while Alphabet's Sidewalk Labs is planning an entire neighbourhood in Toronto. Companies such as Katterra attempt to overhaul traditional construction and architecture with venture capital-backed prefabrication, purchasing multiple architecture offices along the way, such as the celebrated Vancouver based Michael Green Architects. Novel hybrids of real-estate development, lifestyle-brands cum platforms such as the Collective, are developing shared-living communities around the world, shaping new forms of domesticity. This new situation brings a sense of urgency to architectural discourse to reconsider the digital as fundamental for the discipline to remain relevant.

2. Straight from the forest

2.1 Slices

While timber is an obvious choice in the context of the global climate emergency, it also has the potential to transform construction into an automated industry. Previously mentioned platforms such as Katterra and Sidewalk Labs base their entire production chain on the use of timber. This does not come as a surprise as timber production today is already largely industrialised and automated. Responding to the increasing global demand for timber, Sweden's total area of forest has increased over 70% in the last decades. To manage these larger and larger areas, the forestry

industry has heavily invested in end-to-end automation. Forests are now managed digitally, with every tree tracked and stored in databases, its lifetime monitored closely until the day it is finally harvested. Advanced computer vision technologies are developed to analyse forests, segment trees from point-clouds, and model production.

Once harvested, automated machines dissect trees into precise slices and glue them back together into standardised sheets with EN, DIN and ISO standards labels attached. The vast difference and unpredictability of the natural forest is reduced to dimensional tolerances of a millimetre. Whereas traditional timber relied on limited lengths and dimensions of lumber, engineered timber products can now be produced in lengths at wish. These sheets and panels can then be computed, engineered, insured and traded, ultimately becoming standard assets in BIM-software and catalogues. After being shipped, these can be cut with relatively simple machines into customised building elements, in places far away from the original forest.

2.2 Parts

The automated, short production chain advocated by companies such as Katterra and other timber prefabricators is based on a what is known as a "kit of parts" approach. A prefabricated catalogue of parts such as floor cassettes, columns or bathroom units is combined into a complete building. Timber disruptors typically offer end-to-end integration – providing everything from base materials to design, on-site delivery and facility management. Katterra argues that their catalogue of parts establishes choice: unlike the dreaded cookie cutter prefabrication of the 1960s, building designs can now be "mass customised" to the clients wishes (Katterra n.d.). Previously, the term mass customisation was often used by the early generation digital architects to describe the process of creating non-standard forms from thousands of small components. In this context, the notion of mass customisation is, however, very different from the early digital one: this is not a mass customisation of form, where every building component is different, but one based on assembly, from serialised and standardised elements. Rather than experimental form-finding and

generative coding, Katterra's BIM-like software allows them to design and customise buildings from their catalogue of parts.

2.3 Platforms

These emerging timber platforms arguably contribute substantially to a desperately needed change in construction and building culture today, but also raise some pressing questions. From a socio-economic point of view, and under pressure from vast amounts of venture capital, these platforms seek to establish a centralised model that ultimately wants to create quasi monopolies similar to the likes of Uber and Airbnb. As these platforms are end-to-end integrated, there are significant consequences for the business models of non-integrated architects and contractors (Sanchez 2018). In this context, it is worth considering Nick Srnicek's (2017) writing on Platform Capitalism, which explains how the initial premise of the digital as a form of economy with the inherent possibility to democratise production ends up with powerful platform monopolies. In architectural discourse, Jose Sanchez has critiqued this closed box model of vertical integration, arguing that new platforms should be more distributed and empowering to users, citing Trevor Schol's model of Platform Cooperativism as an example (Sanchez 2018). However, this potential danger has to be further nuanced. At present, these emerging platforms are nowhere close to even a regional monopoly and actually contribute in disrupting the prevalent quasi-monopoly of large developers and contractors in a classic design-bid-build model (Claypool et al. 2019), which in most cases offer lower quality and less environmentally friendly products than their upcoming competitors. However, it is important to explore potential alternative models of more decentralised and open forms of automations, which could empower a larger ecology of designers, builders and future inhabitants.

2.4 Kit of parts

From a technical point of view, the new timber platforms are based on a standardised kit of parts approach, commonly associated with modernist prefabrication. This "simplified automation" (Bava 2020), with fixed hierarchies and types, severely limits the



200M Housing Block. Gilles Retsin, 2019.

amount of difference that can be achieved, putting into doubt the earlier promise of mass customisation and design freedom. While this approach significantly reduces the amount of parts in the production chain, thus increasing efficiency, it is not per se a novel approach, nor does it fundamentally disrupt construction as we know it. The proposed production chain remains fundamentally discontinuous and requires

scale and centralisation to create the ultimate, optimised kit of parts. From an architectural perspective, the proposed model erodes the agency of architecture as a discipline and a form of knowledge beyond mere logistics. Architecture becomes a service at the hands of the platform, with the task of making the building product more efficient and giving it marketable visual appeal. For sure, many of the building

prototypes promised by the timber platforms are of high quality, but in what way do they contribute to architecture as a cultural discipline? The role of the architect is reduced to tinkering with an established catalogue of parts, within the constraints of the platform. This critique is not unique to the new construction platforms, also other system-based approaches such as the open source WikiHouse and BuildX initiatives run the risk of reducing architecture to a logistic endeavour, albeit with a more social purpose.

From a domestic point of view, the timber platforms turn "housing" into a mere commodity, the home becomes a facility to be inhabited, an asset to be traded. This critique again has to be nuanced, as this is currently already the case with traditional developers and the housing market in general. The majority of housing is already a market commodity, the unique, architect designed home – with a more metaphysical dimension – is in many countries a rare privilege for the few who can afford it.

2.5 Discrete

An emerging body of work referred to as "Discrete" in architectural discourse, advances an architectural paradigm that emphasises the combination of automation and parts (Claypool 2019). However, in a crucial difference to the new timber platforms, the Discrete argues for a much more open, agile, decentralised and architectural platform. Unlike the modernist "kit of parts" approach, the Discrete approach starts from a digital understanding of parts as function agnostic, generic "building blocks" which through their combination and interaction can establish higher-level functionality – not dissimilar to the Centre for Bits and Atoms' Digital Materials (Gershenfeld et al. 2015). This approach emphasises the discrete nature of computation (Carpo 2014) and reframes architectural parts as voxel-like units (Morel 2011) that can be variably organised and programmed. A body of creative work has emerged by architects such as Jose Sanchez, Daniel Koehler, Rasa Navasaityte and Casey Rehm, which all in their own unique way develop new digital mereologies or organisations of parts. Bypassing the reductive kit of parts, the Discrete combines the efficiencies of modularity and prefabrication with complexity, variability and open-endedness. Buildings

are developed on a "granular" level, increasing the resolution and space of possibilities. Moreover, this approach inherently leads to a short and continuous production chain, where assembly becomes a digital process of assembling repeating base elements, not dissimilar to additive manufacturing (Hiller 2009). Whether the elements are small or large, 3D-printed, assembled by robots, participant-users or human workers, this computational mode of assembly remains unchanged. The premise of the discrete is that efficiencies gained by automation create value which should be invested in architecture itself and its users. While some of the work emphasises more the architectural over aspects of democratisation and participation, it subscribes to a very different understanding of the build environment than the modified vision put forward by the timber platforms. Architecture is understood as a complex cultural discipline, with aesthetic, social, political and economic implications and responsibilities.

3. Discrete automation

3.1 Timber building blocks

The Diamonds House, a 2015 project for a multi-family house in Belgium by Gilles Retsin Architecture, introduces the idea of building function agnostic, discrete building blocks from simple sheet timber materials. The house proposes a limited set of volumetric hollow elements, assembled from Laminated Veneer Lumber (LVL) sheets. These elements are then combined to establish higher-level organisations. Architectural features and functions emerge from the granular assembly of the building blocks, rather than being predefined by architectural or structural types such as the slab, beam, wall or cell. The building blocks are autonomous and pre-exist the specific instance of the built whole itself. The Diamonds House is therefore perpetually in-part-whole. The house does not exist as a one-off but could exist in parallel in endless granular variations. It allows the actual mass customisation of every instance, at the resolution of the part itself, while not requiring any additions to the production chain. This granular mass customisation is therefore only at an informational cost – the simple instruction and evaluation of where to position a specific element.

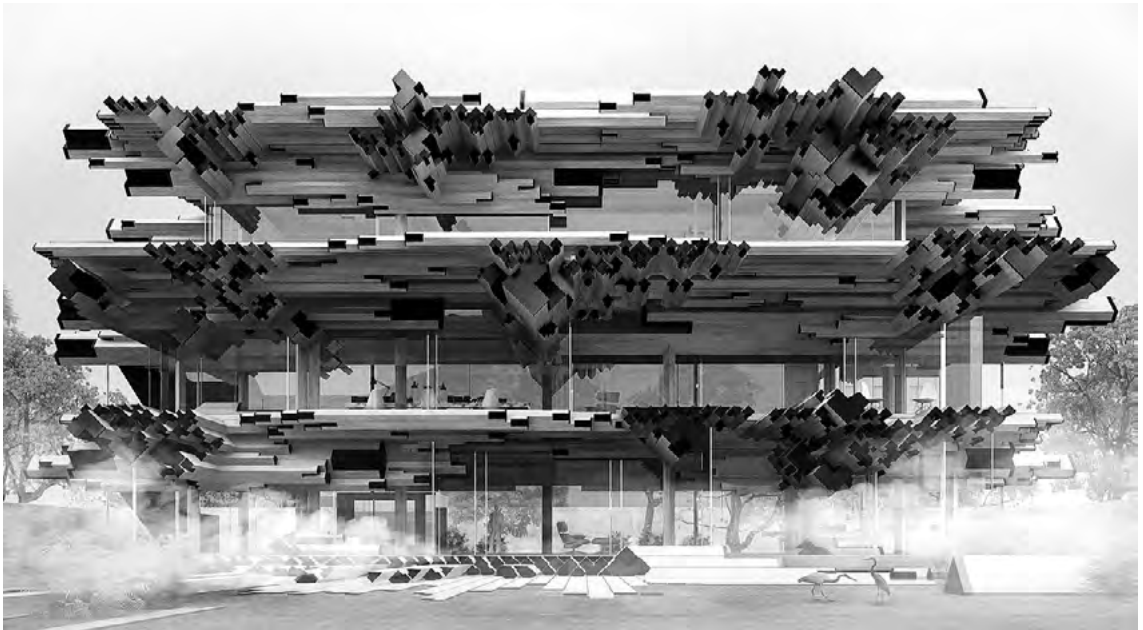

Diamonds House. Gilles Retsin, 2015.

3.2 Prototypes

Beyond tectonics, mereologies and material organisations, the liberation from predefined types and hierarchies results in endless new forms of domesticity, not bound to simple one-two-three bedroom catalogues. The domestic organisation of space is no longer a product of form-function dialectics, but enables exponential variation and freedom for interpretation by respective inhabitants. The same discrete building blocks can be used to construct shared-living spaces, open lofts, co-working spaces, traditional one-bedroom flats or back-garden pavilions. As parts can be reversed, engraved domestic visions and ideas are moreover no longer fixed in time. On an architectural level, the organisation of parts does not necessarily have to result in blurry-pixelated clouds that are now commonly associated with the discrete body of work. Parts could also be organised in different resolutions, with different levels of entropy, and varying ideologies in conversation with disciplinary obsessions such as figure-ground, poche's, subtractions, juxtapositions, chiffres, grids, or open-plans.

A series of 1:1 prototypes were constructed to evaluate and test the premise of the Diamond House. The first is an installation for the Tallinn Architecture Biennale (2017), which is conceived as an abstract fragment of a larger housing block. A family of discrete parts was developed, which can all be derived from a single sheet of 18mm plywood. A standard three-axis CNC machine is used for cutting. The part is designed as a box-beam like element, and an external structural skin with internal frames. These frames are notched in the skin and set out modular connectivity for post-tension rods that run laterally across elements. Unlike traditional post-tensioned structures, these threaded rods only act locally and are therefore in themselves discrete. While architecturally, the elements read longitudinally, the internal stiffening frames and post-tension rods form a continuous structure laterally. This results in a timber monolith composed of parts, which can subsequently be altered, reversed and re-assembled. The TAB installation advances the idea of a discrete granular architecture with endless possibilities of recombination. Assembly moves on from its association

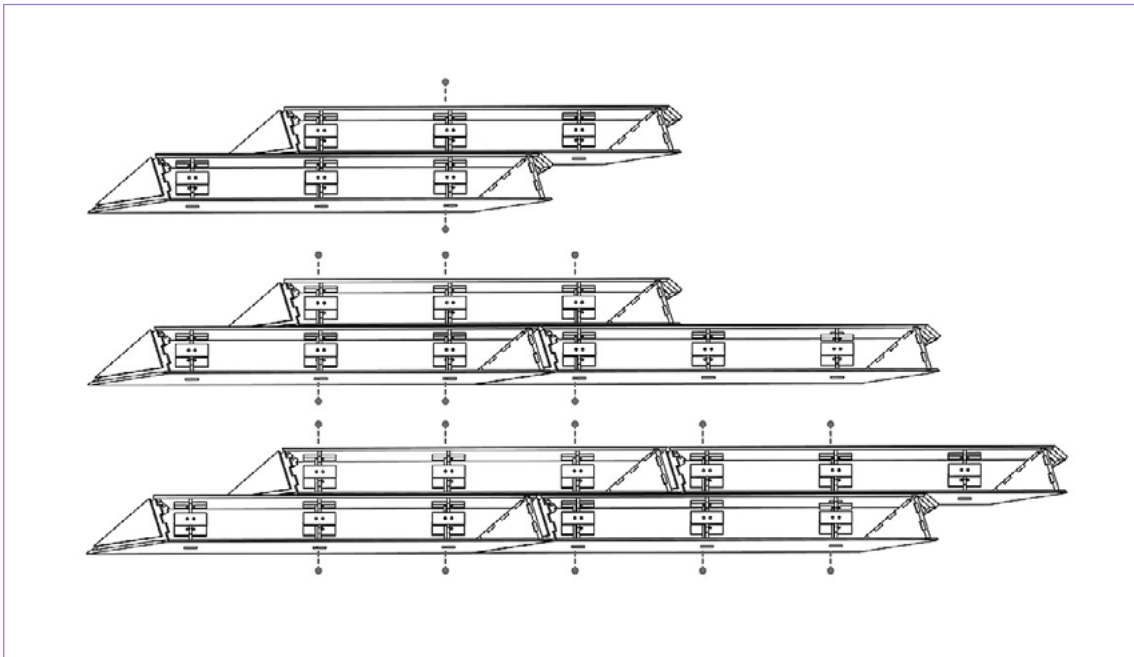
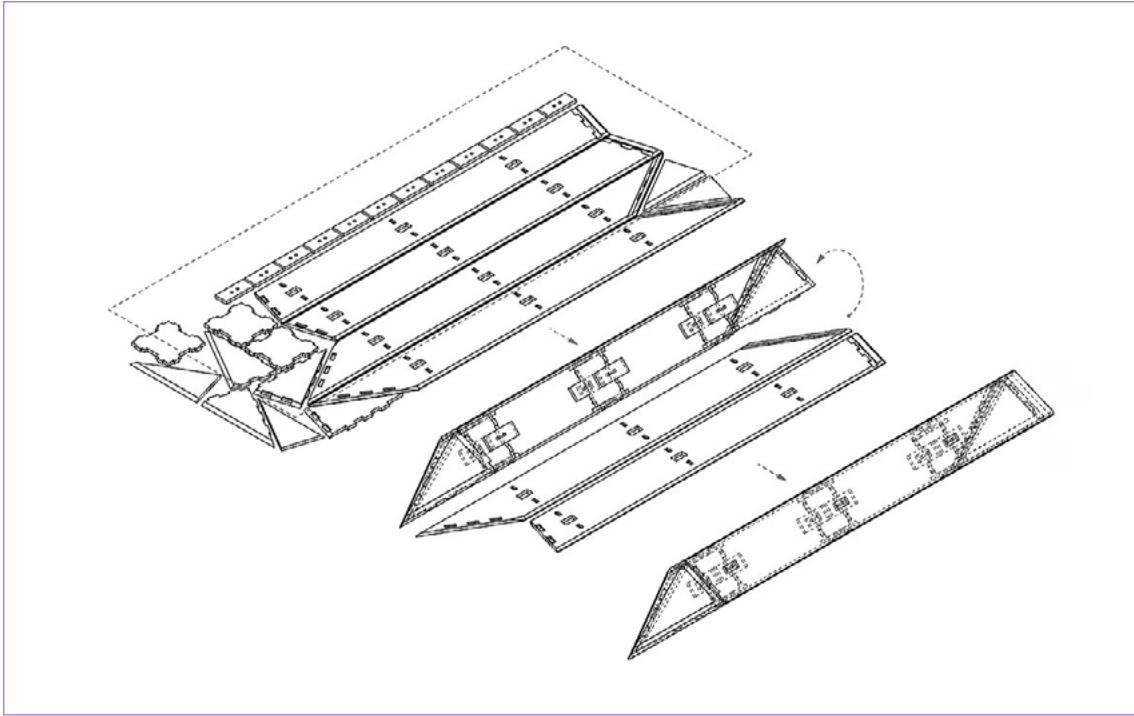

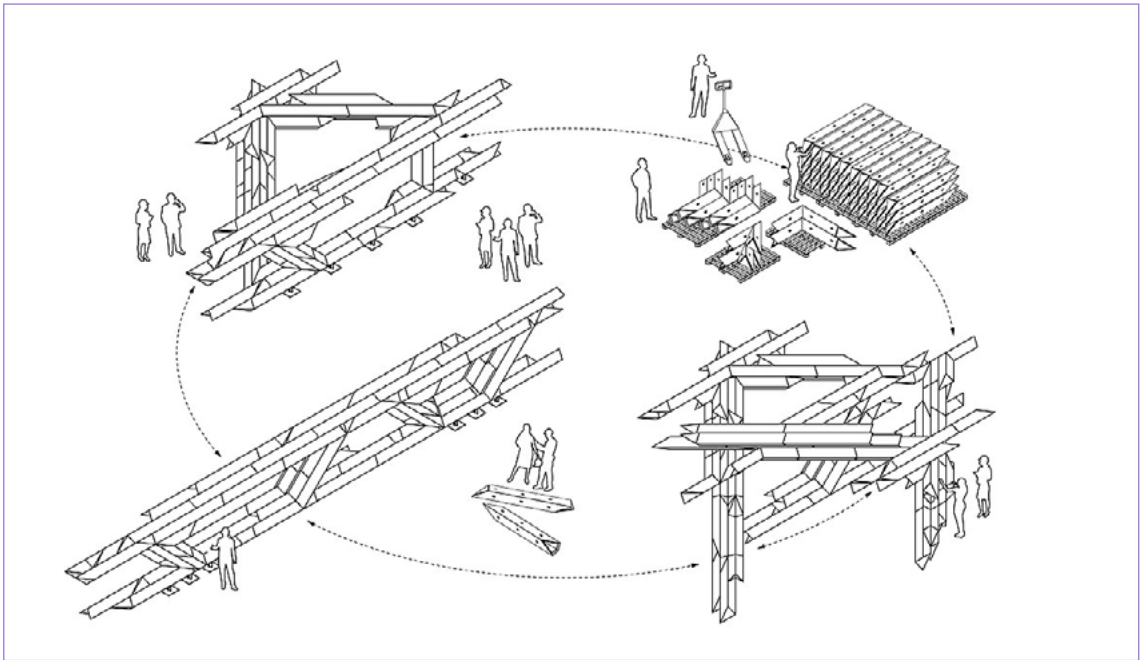

TAB Installation. Gilles Retsin, 2017.



TAB Installation. Gilles Retsin, 2017. Photo: NAARO.

with modernist notions of prefabrication and fixed part-hierarchies to become a digital process. Unlike the examples of digital materials, the parts are deliberately not regular space-filling polyhedra but are asymmetrical. This limits the amount of connection possibilities and granular variation, but on the other hand also establishes a quicker construction sequence and reduces the joints needed.

While Sanchez (2018) argues for non-architect users as active participants in the design process, the work discussed here remains firmly in the hands of architects as authors and unique specialists. By turning towards the monolithic, it even assigns more agency to the architect, resisting the continuous outsourcing of the discipline to specialist consultants. Driven by ever more accessible digital fabrication tools, this model moves in the direction of the architect-as-fabricator, as we know from Jean Prouve and Miguel Fissac.

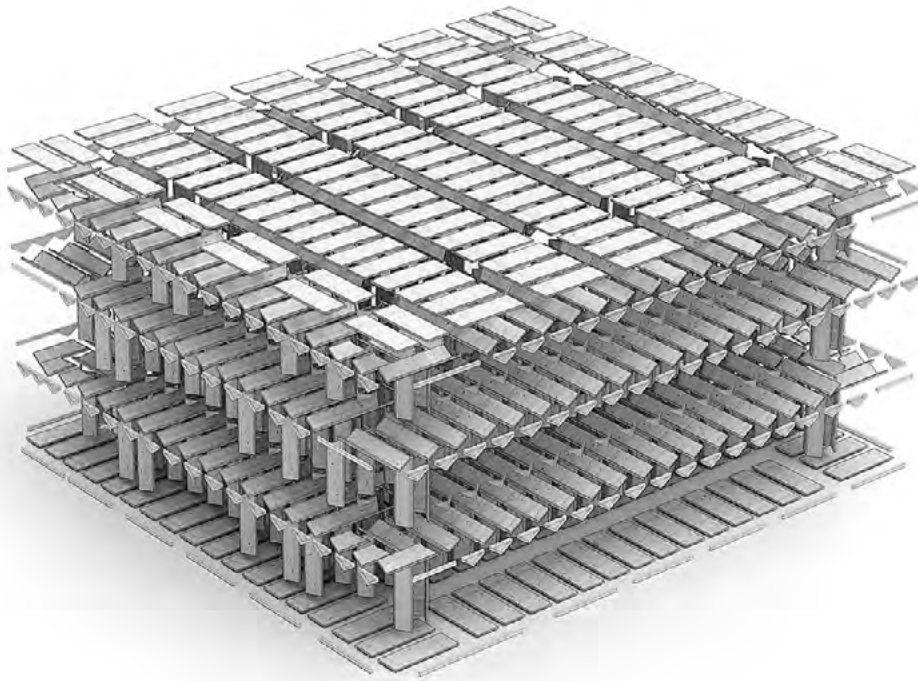

Nuremberg Concert Hall. Gilles Retsin, Stephan Markus Albrecht, 2018.

3.3 Scaling up: Nuremberg Concert Hall

A competition proposal for the Nuremberg Concert Hall, with Stephan Markus Albrecht (2018) scales up the approach of discrete timber elements. Rather than plywood, Cross Laminated Timber (CLT) sheets are assembled into large, repeating elements with a hollow cross section that contain building services. To organise the hundreds of generic timber modules into a functional building, an algorithmic procedure was developed based on a so-called "voxel-space", or a volumetric pixel. An algorithm assembles digital v-shaped patterns into larger structural elements surrounding the functional programme of the concert hall. The voxels translate into repeating CLT plates, which then again form large modules that assemble into specific spatial patterns such as a wall, corner or ceiling. The resulting architectural space

can again be understood as an engineered timber monolith, where walls, ceilings and columns do not exist as functional types but a single, repeating material operation structures the entire building.

The proposal for Nuremberg articulates itself as an apparently simple box-shaped massing; however, it can only really be understood as a series of autonomous parts, which are not derived from the whole and could repeat in other built instances. The project shows how the method, initially developed in plywood, can be scaled up to mass-timber without fundamental differences. At the same time, the plywood prototypes remain a good solution for smaller-scale structures such as house-extensions or single-family houses.



Nuremberg Concert Hall. Gilles Retsin, Stephan Markus Albrecht, 2018.

3.4 Primitive yet fully automated

Just as the first primitive dwellings were constructed from found materials – huts assembled from tree trunks or stones – this fully automated architecture is also directly extracted from the forest. Its extremely short production chain strips architecture from its layers of history, right down to its raw and primordial, monolithic state. A primitive log cabin is not a monolith, but still in conversation with its parts. The logs are recognisably present and remain to a certain extent autonomous from the whole. Preceding types and hierarchies, a single repeated operation constructs everything – not dissimilar to the examples of the projects in Tallinn and Nuremberg discussed earlier.

Contemporary architecture and construction rely heavily on an assembled, discontinuous layering of

thousands of elements, parts and components. It can therefore be understood as the opposite of a monolith, which consists per definition of only "one". While this complicated layering is at the source of many inefficiencies, it also has architectural problems emerging from it. In many cases, the attempt to establish a consistent whole is rendered futile by the many parts that need to be organised. Enormous efforts have to be made in customising the parts to subjugate to the whole, with a time-intensive and expensive coordination process as a result. By making a limited number of large, autonomous parts, the digital discrete overcomes these logistical problems. The resulting architectural quality is that of a strange contradiction: while fundamentally discrete, it appears phenomenologically continuous. It has a monolithic

quality while remaining an assembly of autonomous parts. Consistent and coherent, yet made of parts, this discrete architecture establishes an experience of a "whole" without a whole.

The digital discrete is therefore a continuous – even organic – form of architectural assembly. This has economic, technical and architectural consequences. Economically, the production chain loses its discontinuities and becomes therefore easier to technically automate and integrate. The work breaks the age-old form-function logic, bypasses the modernist kit of parts, and establishes a new kind of architectural syntax.

4. Conclusion

This paper has outlined a specific context of architecture in relation to the digital, before and after 2008. It urges architects to take into consideration

the recent developments of emerging timber construction platforms. It proposes a more open-ended platform, based on discrete building blocks, that has economic, social and architectural consequences. The proposed platform changes from a modernist kit of parts to a digital approach to parts as recombinable voxels. This allows for a higher degree of automation and a shorter production chain, which in turn enables more actors to participate in the production of our built environment. Rather than a capital intensive, large-scale, centralised platform, the proposed model enables an ecology of small-scale entities across architecture, construction and users. The dissolution from a fixed kit of parts to a more granular approach opens up more possibilities to experiment with new modes of domesticity and living, while also emphasising the importance of architecture as a form of cultural production and the significance of housing as more than a commodity or facility.

BIBLIOGRAPHY

Bava, Alessandro. 2020. 'Computational Tendencies'. E-Flux, <https://www.e-flux.com/architecture/intelligence/310405/computational-tendencies/>

Beech, Dave. 2019. *Art and Postcapitalism: Aesthetic, Labour, Automation and Value Production*. London: Pluto Press.

Carpo, Mario. 2014. 'Breaking the Curve'. Artforum 52(6).

Claypool, Mollie. 2019. 'Our Automated Future'. *Architectural Design* 89: 46–53.

Claypool, Mollie, Gilles Retsin, Manuel Jimenez-Garcia, and Vicente Soler. 2019. *Robotic Building: Architecture in the Age of Automation*. Munich: Detail Verlag.

Gerschenfeld, Neil, Matthew Carney, Benjamin Jenett, Sam Calisch, and Spencer Wilson. 2015. 'Macrofabrication with Digital Materials: Robotic Assembly'. *Architectural Design* 85: 122–127.

Hiller, Jonathan, and Hod Lipson. 2009. 'Design and Analysis of Digital Materials for Physical 3D Voxel Printing'. *Rapid Prototyping Journal* 15(2):137–149.

Katerra. www.katerra.com. Accessed 5 October 2019.

Morel, Philippe. 2011. 'Sense and Sensibilia'. *Architectural Design* 81: 122–129.

Noble, David. 1984. *The Forces of Production: A Social History of Industrial Automation*. New York: Knopf.

Sanchez, Jose. 2018. 'Platforms for Architecture'. *Proceedings of the 38th Annual Conference of the Association for Computer Aided Design in Architecture*. Mexico City.

Srnicek, Nick. 2017. *Platform Capitalism*. Cambridge: Polity.



Gilles Retsin

originally from Bruges, Belgium, is an architect and designer now living in London. He has studied architecture in Belgium, Chile and the UK, where he graduated from the Architectural Association. His design work and critical discourse has been internationally recognised through awards, lectures and exhibitions at major cultural institutions such as the Museum of Art and Design in New York, the Royal Academy and the Centre Pompidou in Paris. Retsin won 1st place in the competition for the main installation of the Tallinn Architecture Biennale. He has also qualified with his proposals for the Budapest New National Gallery and concert hall in Nuremberg. He recently edited an issue of *Architectural Design* (AD) on the Discrete and has co-edited *Robotic Building: Architecture in the Age of Automation*, with Detail Verlag. Retsin is Programme Director of the M.Arch Architectural Design at the Bartlett School of Architecture, University College London. He is also co-founder of the UCL Design Computation Lab, which conducts high profile research into new design and fabrication technologies. He worked as a project architect with Christian Kerez in Zurich, before founding Gilles Retsin Architecture.