

Process Considerations

in the Extraction and Recovery

of Plant Virus Vaccines

*a thesis submitted for the degree of
Doctor of Philosophy in Biochemical Engineering
in
October 2001
by
Maile Elizabeth Kahawaluaakalani Seymour
of
University College London*

ProQuest Number: 10016043

All rights reserved

INFORMATION TO ALL USERS

The quality of this reproduction is dependent upon the quality of the copy submitted.

In the unlikely event that the author did not send a complete manuscript and there are missing pages, these will be noted. Also, if material had to be removed, a note will indicate the deletion.



ProQuest 10016043

Published by ProQuest LLC(2016). Copyright of the Dissertation is held by the Author.

All rights reserved.

This work is protected against unauthorized copying under Title 17, United States Code.
Microform Edition © ProQuest LLC.

ProQuest LLC
789 East Eisenhower Parkway
P.O. Box 1346
Ann Arbor, MI 48106-1346

1.2 Abstract

The plant virus cowpea mosaic virus (CPMV) has recently been developed as an antigen presentation system intended for future use in human vaccines. In this work, scale-down process studies of initial extraction and recovery of CPMV were carried out using wild type CPMV as a model for more valuable recombinant variants. Release of contaminating soluble protein was also measured. Process conditions used throughout were suitable for large scale production. Actual processing volumes were of the order of millilitres.

Fresh and frozen CPMV-infected leaf material was disrupted by homogenisation in batch and continuous modes and by bead milling. Rheological measurements of the homogenate indicated shear thinning behaviour with constant minimum viscosity of 0.03 Pa s at typical process shear rates ($>200 \text{ s}^{-1}$). Particle size distributions (mode, 7 microns) showed that cells in the tough plant tissue had been efficiently disrupted. Yields from fresh and freshly frozen leaves were comparable, and extended deep-frozen storage of leaves for up to three years appeared to increase yields, to a maximum of 10.4 mg CPMV per g frozen leaf. Yields varied markedly between plant growth batches.

Salt precipitation with ammonium sulphate (up to 3.1M) and neutral polymer precipitation with polyethylene glycol (PEG) (up to 25%), in single and double cut strategies, were used to recover CPMV from the leaf homogenate with and without prior clarification by low speed centrifugation. For ammonium sulphate, double cut precipitation from untreated homogenate gave the best yields and purification. For PEG, the best strategy was single cut precipitation from clarified homogenate. Both alternatives achieved a volume reduction of 20- to 25-fold from the homogenate to the precipitate pellet, 10-fold from leaf to pellet.

The optimal scale-down process conditions determined for the wild type CPMV were applied to purification of a recombinant muc14-CPMV. Yields for the muc14-CPMV agreed well with those obtained for the wild type.

1.3 Acknowledgements

*"The mind bold
And independent,
The purpose free,
So we are told,
Must not think
To have the ascendant."* (Newman, 1865)

I am grateful for the financial support between 07.10.97-20.10.00 as a Research Assistant on the Vaccines from Plants project, LINK project no. BTL/24/101, funded by the Biotechnology and Biological Sciences Research Council grant no. BCE07274 to Nigel Titchener-Hooker and Peter Dunnill. I would not have joined the project without the enthusiasm of Peter Dunnill at UCL and Tom Seddon at Axis. All plant material, purified virus, CPMV-specific antibodies and some specimen SOPs were kindly supplied by Axis Genetics, where I also had the good fortune to be advised by Helen Young. Dhushy Stanislaus provided me with invaluable technical assistance (including most of the practical work in the third year), sums-checking and camaraderie. The real engineer, *Patrick Nichols, sponsored my writing-up until I gained employment as a Research Fellow on the SPINDIGO project at Reading from 01.01.01.

Personally, I would also especially like to thank my mother, father and brother for having me and enduring my early training; the Beaker Society for its varied entertainments; Katy & Ben for their friendship and emails; and my garden(s) for being there.

1.4 Dedication

To Granny Bec and Granpy Laurie.

1.5 Table of Contents

“Why would evolution ever have selected for sheer bigness of brain, that bulbous, metabolically greedy organ? A large-brained creature is sentenced to a life that combines all the disadvantages of balancing a watermelon on a broomstick, running in place in a down jacket, and, for women, passing a large kidney stone every few years. Any selection on brain size itself would surely have favored the pinhead.”
(Pinker, 1994)

Prologomena.....	1.1.....	Title page	1
	1.2.....	Abstract	2
	1.3.....	Acknowledgements	3
	1.4.....	Dedication	3
	1.5.....	Table of Contents	4
	1.6.....	List of Figures	9
	1.7.....	List of Tables	10
Introduction.....	2.1.....	CPMV & CVPs	11
	2.2.....	Leaf Processing	14
	2.2.1.....	Minimise Denaturation	14
	2.2.2.....	Maximise Yield	16
	2.2.3.....	Sequence of Stages	18
	2.3.....	Process Alternatives at Small and Large Scale	19
	2.3.1.....	Disruption	19
	2.3.2.....	General Sizing of Production Equipment	20
	2.3.3.....	Recovery	20
	2.4.....	Research Aims	22

Materials & Methods.....3.1.....	Guiding Principles	23
3.1.1.....	Chemicals and Reagents	23
3.1.2.....	Containment	23
3.2.....	Plant Growth, Infection and Harvest	25
3.3.....	Extraction	26
3.3.1.....	Freeze-thaw	26
3.3.2.....	Blending	26
3.3.3.....	Batch Homogenisation	26
3.3.4.....	Continuous Homogenisation	28
3.3.5.....	Bead Milling	29
3.3.6.....	Shear Device	29
3.4.....	Assays	30
3.4.1.....	Sample Storage	30
3.4.2.....	Spectrophotometry	30
3.4.3.....	ELISA	31
3.4.4.....	Total Protein	32
3.4.5.....	SDS-PAGE	33
3.4.6.....	Particle Size Measurement	33
3.4.7.....	Dry Weight	34
3.4.8.....	Light Microscopy	34
3.4.9.....	Electron Microscopy	34
3.4.10.....	Rheometry	34
3.4.11.....	pH and Ionic Strength	34
3.4.12.....	Density	34
3.5.....	Precipitation	35
3.5.1.....	Ammonium Sulphate	35
3.5.2.....	Polyethylene Glycol	35
3.5.3.....	Centrifugation	35
3.5.4.....	Filtration	36
3.6.....	Statistical Treatment of Data and Errors	36
3.6.1.....	Presentation of Data	36
3.6.2.....	Purification Factors	36

Assay Development.....	4.1.....	ELISA	37
	4.1.1.....	Description of Assay	37
	4.1.2.....	Standards and Controls	39
	4.1.3.....	Plates	39
	4.1.4.....	Washing	39
	4.1.5.....	Conjugates	39
	4.1.6.....	Standards	40
	4.1.7.....	Blank Background	44
	4.1.8.....	Detection Antibody	44
	4.1.9.....	Stop Reagents	46
	4.1.10.....	Incubation Time	47
	4.2.....	Protein Assay	48
	4.2.1.....	Assay Description	48
	4.2.2.....	Standards and Controls	49
	4.2.3.....	Sources of Error	49
	4.2.4.....	Edge Effects	49
	4.2.5.....	Double Wavelength Reading	49
	4.2.6.....	Interference by Chlorophylls	50
	4.2.7.....	Interference by Ammonium Sulphate	50
	4.2.8.....	Sample Delay	50
	4.3.....	Conclusions	51
Initial Extraction.....	5.1.....	Introduction	52
	5.1.1..	Strategies for Extraction of Virus from Leaves	52
	5.1.2.....	Freeze-thaw	54
	5.1.3.....	Mechanical Disruption	54
	5.1.4.....	Blending and Homogenisation	55
	5.1.5.....	Bead Milling	56
	5.1.6.....	Aims	56
	5.2.....	Results and Discussion	56
	5.2.1.....	Freeze-thaw	56
	5.2.2.....	Blending	57
	5.2.3.....	Milling	57
	5.2.4.....	Batch Homogenisation	59

5.2.5.....	Batch and Storage Variability	64
5.2.6.....	Continuous Homogenisation	68
5.2.7.....	Scale-down Shear Device	71
5.2.8.....	Particle Size and Rheology	74
5.3.....	Conclusions	79
Ammonium Sulphate Precipitation	6.1	Introduction 80
	6.2	Results and Discussion 83
	6.2.1.....	Single Cut 83
	6.2.2.....	Double Cut 88
	6.3	Conclusions 93
PEG Precipitation	7.1	Introduction 94
	7.2	Results and Discussion 98
	7.3	Conclusions 111
Wild Type & Recombinant	8.1	Introduction 112
	8.2	Methods 113
	8.2.1.....	Processing 113
	8.2.2.....	SDS-PAGE 113
	8.3	Results 114
	8.4	Discussion 117
	8.4.1.....	Wild Type 117
	8.4.2.....	Recombinant muc14-CPMV 118
Summary	9.1	Assay Development 120
	9.1.1.....	ELISA 120
	9.1.2.....	Protein Assay 120
	9.2	Initial Extraction 121
	9.3	Ammonium Sulphate Precipitation 122
	9.3.1.....	Experimental Variables 122
	9.3.2.....	CPMV Product 122
	9.3.3.....	Protein Contaminant 122
	9.4	PEG Precipitation 123
	9.4.1.....	Experimental Variables 123

9.4.2.....	CPMV Product	123
9.4.3.....	Protein Contaminant	123
9.5.....	Wild Type & Recombinant	124
9.6.....	Process Conclusions	124
Future Work.....	10.....	125
Afterwords.....	11.1.....	References 126
	11.2.....	Acronyms & Abbreviations 134
	11.3.....	Example SOPs 137
	11.3.1.....	ELISA 137
	11.3.2.....	Protein Assay 140
	11.3.3.....	SDS-PAGE 141
	11.4.....	Process Flowsheets 145
	11.4.1.....	Wild Type CPMV 145
	11.4.2.....	Recombinant muc14-CPMV 147
	11.5.....	Intellectual Property 149
	11.5.1.....	History of Axis Genetics 149
	11.6.....	Safety 150
	11.6.1.....	MAFF 150
	11.6.2.....	HSE 150
	11.6.3.....	UCL 151
	11.7.....	Economics 151
	11.8.....	Author Contact Details 151
	11.9.....	Further Processing 152
	11.9.1.....	Avoidance 152
	11.9.2.....	Alternative Extraction 152
	11.9.3.....	Precipitation 153
	11.9.4.....	Solvent Partitioning 153
	11.9.5.....	Filtration 153
	11.9.6.....	Chromatography 154
	11.9.7.....	Additional References 155

1.6 List of Figures

Figure 1. Comovirus and picornavirus particle structure.	12
Figure 2. The Silverson batch homogeniser.	27
Figure 3. The smallest scale-down continuous Silverson high shear homogeniser.	28
Figure 4. Effect of assay loading delay on measured virus and protein contents.	30
Figure 5. Template for ELISA.	31
Figure 6. Template for protein assay.	32
Figure 7. Absorbance response with increasing CPMV concentration.	41
Figure 8. CPMV standards changeover calibration.	42
Figure 9. Multiple comparisons test.	43
Figure 10. Test of tenfold range of 10B7 dilutions.	45
Figure 11. Effect of SDS stop reagent.	46
Figure 12. Comparison of fast and slow incubation times.	47
Figure 13. Scanning electron micrograph of a freeze-fractured cowpea leaf.	52
Figure 14. Batch homogeniser speed during processing.	59
Figure 15. Yields from fresh leaves of four individual plants.	60
Figure 16. Release from frozen leaves homogenised for 0-240 s.	61
Figure 17. Comparison of yields from fresh and frozen leaves of different batches.	62
Figure 18. Batch to batch variation in yields.	64
Figure 19. Effect of extended deep-frozen storage on homogenisation yields for a typical batch.	66
Figure 20. Correlation of yields with previous storage at -80°C across all batches.	67
Figure 21. Temperature effects during batch and continuous homogenisation.	68
Figure 22. Protein release from batch and continuous homogenisation.	69
Figure 23. CPMV release from batch and continuous homogenisation.	70
Figure 24. CPMV and protein yields in the scale-down shear device.	72
Figure 25. The same particle size distribution, frequencies by number and by volume.	74
Figure 26. Change in particle size distribution with homogenisation time.	75
Figure 27. Rheological behaviour of homogenate under shear.	77
Figure 28. Profiles of single cut ammonium sulphate precipitation.	84
Figure 29. Fractionation diagrams comparing CPMV with protein.	87
Figure 30. Double cut precipitation on a yields per unit mass basis.	89
Figure 31. Second cut fractionation diagram.	90
Figure 32. CPMV precipitation by PEG.	98

Figure 33. Total protein precipitation by PEG.	99
Figure 34. CPMV and protein precipitation by PEG from clarified homogenate.	100
Figure 35. CPMV precipitation by PEG from clarified homogenate.	101
Figure 36. Total protein precipitation by PEG from clarified homogenate.	102
Figure 37. CPMV and protein precipitation in three runs.	103
Figure 38. CPMV and total protein precipitation by PEG from clarified homogenate.	105
Figure 39. CPMV and protein precipitation by PEG from clarified homogenate.	106
Figure 40. Fractionation diagram of CPMV against protein.	107
Figure 41. SDS-PAGE gels.	109
Figure 42. A simplified process flow diagram.	113
Figure 43. Wild type CPMV purification by precipitation.	115
Figure 44. Recombinant muc14-CPMV purification by precipitation.	116
Figure 45. Wild type CPMV process flowsheet.	145
Figure 46. Recombinant muc14-CPMV process flowsheet.	147

1.7 List of Tables

Table 1. CPMV-infected plants' growth batch designations.	25
Table 2. Details of molecular weight markers used in SDS-PAGE.	33
Table 3. Standard and control concentrations routinely used in ELISA.	39
Table 4. Standards and controls for protein assay.	49
Table 5. Plate layout test comparing edge and middle wells.	49
Table 6. Protein yields after disruption by various methods.	57
Table 7. Comparison of CPMV yield and soluble protein contamination after disruption.	63
Table 8. Comparison of batch and continuous processing results.	73
Table 9. Details of ammonium sulphate precipitation experiments.	93
Table 10. PEG experimental details.	110
Table 11. Wild type CPMV purification values.	114
Table 12. Recombinant muc14-CPMV purification values.	114

2. Introduction

"Yet if engineers were the very first professionals in history, philosophers appeared soon after. By starting from statements simple enough to be self-evidently true, they claimed that strictly logical argument would find the answers to all fundamental questions. Except that it did not, of course.

'I observed with regard to philosophy,' remarked Descartes several millenia later, 'that despite being cultivated for many centuries by the best minds, it contained no point which is not disputed and hence doubtful.'

Still, the notion of starting from simple premises and developing a theory by logical argument took hold. Finally somebody, somewhere had the idea of combining philosophical precision of argument with the engineering habit of trying out the conclusions to see if they worked. A kind of cultural fusion reaction produced something new, strange and wonderful. Thus was science born." (Gosling, 2000)

2.1 CPMV & CVPs

Wild type cowpea mosaic *comovirus* (CPMV) is a tropical plant virus which efficiently infects and replicates in species such as *Vigna unguiculata*, the black-eyed bean or cow pea. Infected secondary leaves show a characteristic yellow mosaic pattern. Isolated protoplasts (plant cells with their cell walls removed) contain over 10^6 progeny virus per cell, 9-24 h after infection (Hibi *et al.*, 1975).

CPMV particles are icosahedral with average diameter 28.5 nm (Lomonossoff and Johnson, 1991)*. There are three types of particle, which are empty (the top, or T, density fraction) or contain either the larger or smaller segment of the two part ssRNA genome (the bottom, B, and middle, M, fractions). These fractions occur in the ratio 1:2:2 respectively. Empty shells are the least stable, for example to a combination of pressure and urea or low temperature treatment to -20°C (Da Poian *et al.*, 1995; Da Poian *et al.*, 1994), but otherwise all particles are identical in surface features.

Some physical properties of CPMV particles which have been previously described, and may indicate strategies for processing, include isoelectric points (pI or IEP) for the wild type of pH 3.7-4.5 (van Kammen and de Jager, 1978) or pH 5-7 (de Jager, 1996); this implies an acidic surface chemistry with some buffering capacity. Densities are 1.29, 1.40, and 1.45 g cm^{-3} (T, M, B) (Lomonossoff and Johnson, 1991), and sedimentation coefficients are between 60-119 $S_{20^{\circ}\text{C, water}}$ (de Jager, 1996).

* The accepted (spherically averaged diameter) particle size for wild type CPMV is 28.5 nm (Schmidt *et al.*, 1983), although reported values vary (see discussion in Lomonossoff and Johnson, 1991): 20-24 nm negatively stained with uranyl acetate by transmission electron microscopy (TEM); 28.5 nm by hydrated, freeze-sublimated scanning electron microscopy (SEM); 30.8, 27.2, and 25.4 nm along 5-5, 3-3, and 2-2 symmetry axes by X-ray crystallography; particles also expand in caesium buffers at alkaline pH.

The CPMV capsid (protein coat) is made up of 60 copies each of two types of tessellating subunits, which afford a large protective volume while economising on genome coding space (Figure 1, taken from Chen *et al.*, 1989). The large, L, coat protein subunit is 42 kDa and the small, S, 22 kDa. Assembled CPMV particles show a striking structural similarity to animal picornaviruses, such as foot-and-mouth disease virus (FMDV). This suggested the possibility that the immunogenicity of the animal viruses might also be mapped onto CPMV.

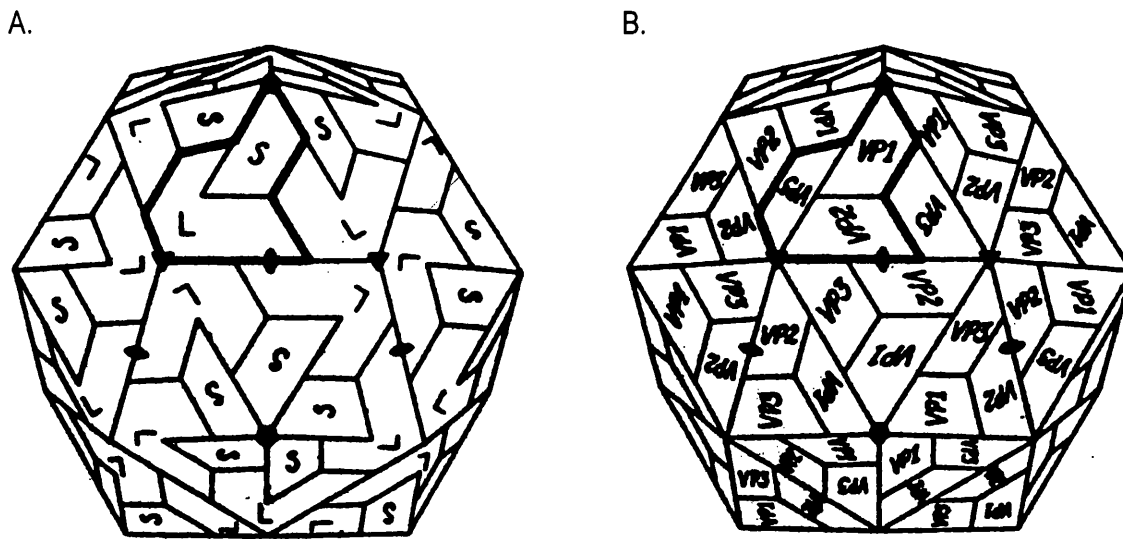

Figure 1. Comovirus and picornavirus particle structure.

A: comovirus, L, S coat proteins; B: picornavirus, VP1, VP2, VP3 coat proteins. Axes of symmetry through whole particle: ●, fivefold (5-5); ▲, threefold (3-3); ◆, twofold (2-2).

Picornaviruses (family Picornaviridae) include FMDV, polio virus, rhinoviruses, and hepatoviruses. Parvoviruses (genus Parvovirus, family Parvoviridae) include feline parvovirus, mink enteritis virus (MEV), canine parvovirus, human parvovirus B19, and adeno-associated viruses. Picornaviruses and parvoviruses have similar icosahedral particles, and work has been done on antigenic determinants from both families.

Distinctive surface loops extending from the coat proteins of pathogenic viruses are recognised by the immune system as antigenic determinants. Three different natural plant comoviruses have highly variable protein structures in the loop region, in both primary (amino acid sequence) and tertiary (three-dimensional domain) structure (Lin *et al.*, 1996). In CPMV, there is a small (8 amino acid) surface loop detail, for which the genetic location is known and insertion vectors have been created. Inserts up to 30 amino acids long have been made: the particles assembled correctly *in planta*, with the antigenic fragment adopting near-native conformation in some cases (Porta and Spall *et al.*, 1994). Chimeric virus particles (CVPs) made in this way are not much bigger than wild type particles, for example 31.7 nm diameter (33.4 nm

maximum) with a 14 amino acid insert from human rhinovirus (HRV, a picornavirus) (Lin *et al.*, 1996).

In this way, CPMV can be used as an antigen presentation system. The wild type has a large enough protein structure to be immunogenic itself (Stace-Smith, 1981) - even conferring mild crossover immunogenicity against structurally similar pathogens - and enhances the response to peptide fragments co-presented with it in a formulation. Antigens attached to CPMV stimulate the desired antibodies even without adjuvant in the formulation, e.g. a mucosal immune response in mice (Brennan *et al.*, 1999). CVPs remain infectious to plants.

In 1997 proof of principle for such CVPs was provided by Dalsgaard *et al.* In their study, mink were protected against a lethal challenge of mink enteritis virus (MEV, a parvovirus) by inoculation with recombinant CPMV particles. The CVPs performed better, weight for weight of the active epitope, than a commercially available killed-MEV vaccine. The strategy is also applicable to new classes of immunogens such as cancer cell markers. Over 50 antigenic peptides from a variety of human and animal pathogens have been incorporated into CVPs to date. These include HIV, HRV, Norwalk virus (causing travellers' diarrhoea), hepatitis B, cholera, *Pseudomonas aeruginosa*, *Staphylococcus aureus* (causing mastitis), FMDV, and MEV.

Some advantages of transient expression in plants using plant viruses, compared to nuclear transformation of whole plants, are:

- precise, easy and rapid (retroviral) insertion of desired genes into small RNA virus genomes
- rapid replication, producing large quantities of product in weeks rather than months
- further increase by inoculation of infected sap to healthy young plants
- near-uniform response at first passage in host population
- over 100× higher expression
- use of plant species for which no stable DNA transformation or regeneration protocols exist
- avoidance of vertical transmission (escape of transgenes) through pollen or seeds

In addition, there have never been reported any intrinsic pathogenic effects of any plant virus on humans or animals (Chapman and Wilson, 1997). In contrast to the use of animal viruses grown in cell culture, there is no possibility of contamination from adventitious pathogenic agents in serum-containing propagation media or in the host cell line, or of reversion of an attenuated virus to a virulent form.

To make a plant virus vaccine, a foreign nucleic acid sequence encoding a short immunogenic peptide is inserted into or fused to the coat protein gene of the plant virus. The foreign antigen is then displayed on the surface of virus particles propagated in plants. Each virus particle contains 60 to 2000 or more copies of the coat protein-foreign peptide fusion, and amplifies, stabilises and enhances the immunogenicity of the peptide. Popular plant viruses

used, in addition to CPMV, are tobacco mosaic *tobamovirus* (TMV) and potato virus X *potexvirus* (PVX), both rod-shaped (indefinite length) viruses. TMV particles contain over 2100 identical coat protein subunits, offering a display system for peptides up to 22 amino acids long. PVX forms flexuous rods with approximately 1300 coat protein subunits of 25 kDa each. These have been fused to exogenous proteins up to 33 kDa in size while retaining the capacity to assemble correctly. Progeny particles were twice as wide as usual and formed up to 10% of total soluble leaf protein, and up to 0.5 mg g⁻¹ wet leaf weight (Santa Cruz *et al.*, 1996). Total molecular weight was upwards of 50 000 kDa with 200-2000 copies of a 30-300 amino acid insert per particle.

2.2 Leaf Processing

“Throughout the procedure, care must be taken to minimise protein denaturation, modification and degradation and maximise yield. Speed of operation and the application of the minimum number of unit operations contribute greatly to the overall efficiency of any purification procedure. Wherever possible, unit operations in a multi-step procedure should complement one another in their requirements and selectivities. Proteins should be purified only to the extent required for the final purpose.” (Jervis and Pierpoint, 1989)

2.2.1 Minimise Denaturation

The S coat protein is typically ‘trimmed’ near its N-terminus. This proteolysis occurs readily, although probably not before capsid assembly, and can go to at least 80% completion (Lin *et al.*, 1996). Because some trimming was always detected, however quickly the CVP was purified [using a construct with 22 amino acid insert from HIV-1 gp41], it was suggested that it may occur *in planta* (Lomonosoff and Johnson, 1991). C-terminal loop processing, ‘cleavage’, also always occurs on storage of construct (Lin *et al.*, 1996). Both ends of the loop remain associated with the intact virion, although the fragments run freely in an analytical denaturing gel (SDS-PAGE). Preferential breakpoints are evident in all CVPs made as described, aided by the unnatural conformational strain in the lengthened loop.

The ability of a CVP to provoke an appropriate immune response as a vaccine or be detected by analytical ELISA depends on the three-dimensional regions recognised by the relevant antibodies. In addition, the side-chain chemistry of the particular amino acids used may affect the physical fragility of the loop region or the distribution of surface charges over the entire particle. If loop damage attenuates the signal presented by the therapeutic epitope, the value of the vaccine will be reduced. Uncleaved preparations are therefore sought for therapeutic use. The profile of cleavage over the surface of a single particle or between particles in a preparation has not been amenable to characterisation (T.B. Seddon, personal communication). However,

the typical discrete 2- or 3-banded pattern in SDS-PAGE is usually interpreted as whole, partially cleaved, and fully cleaved S coat proteins, uniformly distributed over the surface of each particle. The different degraded forms are also resolved in hydrophobic interaction chromatography (HIC), according to their various surface charges.

Metachromatic effects have been observed in cowpea extracts (C.A. Spicer, personal communication), implying the presence of phenolic compounds. Proteases which post-translationally cut CPMV near the N-terminus of the small coat protein ('trimming') are thought to act *in planta* (Lomonosoff and Johnson, 1991); additionally, all insertion construct CVPs to date undergo C-terminal 'cleavage' (Lin *et al.*, 1996). The cleaved fragment remains associated with the virus particle, since the N-terminal 22 amino acids of the S coat protein are an integral part of the β B sheet protein tertiary structure. Direct evidence for this exists for another chimera containing a 14 amino acid insert from HRV, for which the crystal structure has recently been solved. In this case all the epitope loops have undergone cleavage (Lin *et al.*, 1996). Purified uncleaved preparations are stable for more than a year in chilled storage. Damaged product can be adduced from the banding pattern in SDS-PAGE, with positive virus identification by Western blotting. However, intact particles are not necessarily a prerequisite for immunogenicity; intriguingly, in recent animal trials, chromatographically purified, completely cleaved virus still conferred some protection (D. Warne, personal communication). Extracts from the youngest leaf tips only (dubbed "tea picking") show much less cleavage than whole plant harvests (none in a gel immediately and 70% of yield remaining uncleaved over the whole process), for a less stable construct (S.J. Taylor, personal communication). The tradeoff is a lower dry weight of infected leaves per plant per harvest or per m² of growth area, approximately half. This technique compares to the high-intensity outdoors machine harvesting, akin to repeated mowing, of a crop such as tobacco in the USA.

Chimeric constructs may be conformationally strained or unnaturally freely moving at the insertion site, especially following the characteristic cleavage (Taylor *et al.*, 1999). They are particularly susceptible to degradation on a processing timescale of days. Changes in molecular mass may be visualised in SDS-PAGE using a protein stain.

Endogenous enzyme activity could be reduced by the addition of protease inhibitors, but these are neither favoured by purity nor economic considerations in large scale purification. In-process, cooling to slow protease action can be routine, but will have no effect if degradation has already occurred before harvesting. Sometimes, natural heat rises during processing can be used to denature unwanted compounds under conditions where the product is thermally stable. In-process stability is an important issue at the extraction stage. Delaying sample assay by

between 1 min and 25 h made no difference to measurement of either virus or protein (Figure 4), implying that any degradation experienced here was practically instantaneous, and possibly unavoidable. Sometimes, natural heat rises during processing can be harnessed to denature unwanted compounds under conditions where the product is thermally stable. Wild type CPMV is reported to retain plant infectivity despite heat treatment up to 60°C, but since its naked nucleic acid is infective, this does not imply that the surface protein structure (as detected by ELISA and necessary for therapeutic use) remains undamaged.

2.2.2 Maximise Yield

Traditionally, the laboratory process for virus extraction has been less concerned with quantitative recovery of the virus than of purifying it from other components, particularly related pathogens. Bioassays in susceptible host species quantified the amount of virus present as an endpoint dilution (DEP) of sap, beyond which infectivity was lost. Here, a sensitive and precise immunological method (ELISA) was used to quantify the amount of CPMV present in even crude homogenates.

Levels of transgenic (exogenous) protein expression, whether from random or targeted insertions, are fairly low and usually range from 0.01-1.00% of the total soluble protein in a plant. Total soluble protein itself comprises only about 4-5% of the plant's dry weight, the rest being fibrous, structural, storage or soluble carbohydrates. Up to 90% of the wet weight of a plant is, of course, water. (Chapman and Wilson, 1997)

Purified CVP yields of up to 1 to 2 mg g⁻¹ of fresh weight of infected plant tissue have been reported. For example, 50-60 mg was obtained from 5 plants, or c.50 g of leaf material (Dalsgaard *et al.*, 1997). An indication of the potential yield *in planta* is given by the following calculation:

virus diameter 30 nm approx.
 cell diameter 30 μm approx.
 ∴ 1000× bigger in each linear dimension
 ∴ 10⁹ × volume ratio
 reported yield 10⁶ viruses per cell
 assume similar density of virus and cell
 ∴ fraction of cell occupied by 10⁶ viruses is 10⁶ / 10⁹ = 10⁻³ → 1 mg g⁻¹

It is likely then that cellular contents of virus exceed 10⁶ per cell, since 1 mg g⁻¹ survive a multistep purification.

Axis' unpublished, internal reports quoted an overall yield of 6%, of which a 55% yield to clean solution is possible (mg g⁻¹ basis not given). This (6%) means that 1400 plants are

required to produce 1 g of product CVP. Additional assumptions of 70 plants per kg fresh weight* at harvest with a 20% reject rate (dead or asymptomatic) and 85-90% step yields in all processing steps were also made (B. Batas, personal communication). 50 plants are grown per m² under contained growth room conditions. Whether the plant material is grown in contained conditions or in the open will have an enormous impact on the cost-effectiveness of plant virus vaccine production. Other information is required to determine the feasibility of production of plant virus-based vaccines:

- epitope (ng) per CPMV particle (ng)
- maximum yield of CPMV (mg) per cell or leaf (g)
- leaf fresh weight (g) per plant
- plants per m² → size of growth facility, and whether this can be contained
- reject plants at harvest (%)
- harvests per year, considering turnaround time (2 weeks seed to infect, 3 weeks infect to harvest), cleaning and maintenance, propagation problems, holidays
- volume (m³) taken up by stored frozen leaves (kg) → size of frozen storage facility
- batch processing size limit, if batch is required for separate CVPs or for validation purposes
- efficiency of extraction, incorporated in maximum yield above
- yield per process step (%)
- steps per process required for desired purity
- epitope (ng) per effective dose (ml)
- doses per treatment
- treatments comprising annual world market for vaccine

While maintaining an acceptable yield, purification must be achieved, in which CPMV particles will need to be separated from host components such as free ribosomes of similar size and shape (25-30 nm), organelles of similar density, mitochondria (1.18 g cm⁻³) and chloroplasts (1.22 g cm⁻³), as well as fragments and aggregates created by disruption.

CPMV-infected cells develop large cytopathological structures of membranous vesicles grouped into a reticulum, with many virus particles visible by electron microscopy. Double stranded nucleic acid is present, although the viral genome is single stranded, so these are thought to be the sites of virus synthesis and assembly (de Zoeten *et al.*, 1974). Crystalline rafts of particles have also been reported. It is not known how physically robust these structures are. They may comprise a non-interactive close packing of regular particles at high concentration, or possess a further structure which may be resistant to disruption and release during processing.

* 14.3 g per plant, whereas our material averaged 8.3g each

2.2.3 Sequence of Stages

Each additional unit operation in a process:

- increases capital and running costs
- increases complexity of operation, cleaning and downtime
- decreases yield of product, since 100% efficiency is not possible
- must be evaluated for potential hazards and breaches of approved operating practice

For example, the last consideration excluded large-volume solvent extraction on the multiple grounds of chemical risk to operators, reactive safety of stored chemicals, and the environmental burden of disposal after single-use.

A scale-up trial at 1/10 final scale was carried out at Axis with a variant CVP. Approximately 200 mg of product was recovered from 750 g of leaves used, an estimated recovery of 10%. The whole process took 4 d.

In Axis' proposed production scheme, disruption by blending then bead milling was followed by solvent extraction of pigments and lipids using chloroform and butanol. Centrifugation and decanting were used for separation of the virus-containing aqueous phase from the green organic phase. Then, 'debulking' precipitation by ammonium sulphate or PEG was carried out with harvesting centrifugation, retaining the clarified supernatant. This was filtered through a borosilicate glassfibre depth prefilter rated at 0.5 μm , followed by a series of membranes decreasing in pore size from 1.0 to 0.4 to a sterile deadend 0.2 μm filter. Next, anion exchange (AEX) and hydrophobic interaction chromatography (HIC) steps were used in series. For example, a high salt solution from which unwanted protein had been removed by ammonium sulphate precipitation could be used directly as a high salt feed to HIC. Finally the purified extract would need to be UV-treated to destroy native nucleic acid, before undetermined drying, formulation and packaging steps resulting in a sterile lyophilised, reconstitutable vaccine containing CVPs as the active pharmaceutical ingredient (API).

Special consideration was necessary of construct stability during processing (H.A. Young, personal communication). In a crude form (blended or milled) variant CPMV was typically stable for 1 d at 4°C, with no detectable trimming or cleavage by gel with silver stain and ELISA. Soon after, it started to degrade and by 5 d, all was cleaved. This is thought to be due in part to endogenous protease activity (protease inhibitors have slowed the damage) and in part to local conformational strain. Once it has been purified as an uncleaved fraction out of anion exchange, solutions are stable for a year at 4°C. Therefore, it would be beneficial to speed up the process, because the quicker the process moves before AEX, the more of the uncleaved product remains. Precipitation can either take a couple of hours or be left overnight (between working days) and

continued the next day. Typically precipitation and HIC took 30 h in total at room temperature. After single cut precipitation, two filtration steps were employed, to clean up the feed for HIC. Losses of at least 20% were found, and the filtrations took 3 h. It would be a great advantage if these were not necessary.

It was decided that at UCL it would be important first to find out the original, or maximum detectable, quantity of CPMV available, then to work through the process stages quantifying their efficiency and contribution to the whole process with regard to this baseline.

2.3 Process Alternatives at Small and Large Scale

2.3.1 Disruption

Many historical, lab methods would not be useable in a continuous or scaled-up process, even with the efficient CVP expression. For example, freshly picked leaves can be ground by hand in a mortar-and-pestle, under liquid nitrogen, which gives a fine powder. This achieves rapid, but imprecise, disruption of very small quantities. It must be carried out quickly, before the nitrogen evaporates, and immediately followed by the addition of buffer. The cost of liquid nitrogen is also high per unit volume of product recovered, making this a technique only for very small scale and qualitative application.

Blending in a jug-type blender, such as the famous Waring Blendor®, is used for batches of up to 5 L. The method is inherently limited to small-scale batch operation, due to the container assembly and top-loading construction. It can be splashy and large pockets of air can be trapped in viscous fluids, leading to poor mixing. Aerosolisation during unloading may also be a problem. Particularly in small volume operation, it was found difficult to avoid holdup losses of up to 10% of material (remaining in the container). A juice extractor is a similar type of disruptor which is useful on a small scale (Matthews, 1991). It first extracts sap by blending, then separates liquid juice from fibrous squeezed pulp by sieving combined with centrifugation.

Agricultural technologies such as the pulper designed and popularised by Pirie (1971) are available, which harvest and convert leaves directly into a high-protein sap extract without the addition of any liquid. Continuous operation is possible but the extract is not contained and virus-laden aerosols would escape from infected leaf processing in the field.

Some equipment is capable of continuous operation, acceptable containment, and thorough cleaning-in-place (CIP). Various commercial models of bead mills and high shear homogenisers are available in a wide selection of capacities. Bead mills of different sizes are directly comparable over short size ranges. The comparison is based on the number of effective

continuous stirred tank reactor elements they contain (the number of blades in series). They can be cooled in operation by external jacketing but do require a pumpable feed to the narrow inlet piping. Hence maximum viscosity and maximum particle size limits apply to the feed mixture.

Particular models of high-shear homogenisers with cutting teeth and integral pumping action are described in more detail in Materials & Methods sections 3.3.3 Batch Homogenisation on page 26 and 3.3.4 Continuous Homogenisation on page 28, and in Initial Extraction, 5.2.2 Blending on page 57. Both batch and continuous versions were tested. In-line continuous processing guarantees that the process fluid must pass through blades at least once in the stage before emerging. For multiple passes a recirculation loop must be set up or several machines installed in series: the latter option incurs a high setup cost but processing should be quicker and more replicable. Batch operation, with a longer residence time, allows on average hundreds of passes to be made during a few seconds' operation.

2.3.2 General Sizing of Production Equipment

No process is continuous forever, so how long a batch reasonably operates? Limiting factors may be upstream, e.g. size of a contained plant growth facility determining the harvest for one construct; or downstream, for example the spare capacity in storage. The wastage volumes and therefore costs at startup and shutdown for each campaign (different product) are pertinent to the decision to choose a batch or a continuous facility.

Regulatory requirements for vaccines administered by the parenteral (injection) or mucosal (drops via the mouth and nose) routes are purity and documentation. In order to produce the traceability that this implies, in view of the likelihood of mass carryover throughout a continuous campaign, separate-batch processing may be favoured. Validation of cleaning between batches then provides an assurance that, should one batch fail, prior and subsequent ones are not affected.

2.3.3 Recovery

Disrupted material must be clarified sufficiently to avoid subsequent fouling of expensive chromatography columns downstream. On a small scale, filter capsules and flat deadend filters were used. Cellulosic filters were not used because of potential interactions with cellulases released from ruptured plant cells. At Axis, an inert, glassfibre depth filter was used, followed by dead-end or defined pore size membranes to 0.2 μ m. The sterile filtrate could be stored if necessary before further processing. This might be useful if chromatographic capacity is

restricted in the next step. Filters made of polyethersulphone (PES) were found to be the least virus retaining, but losses were around 20% at best.

Testing of various types of production scale filtering or sieving equipment was carried out at Axis. Crossflow filtration membranes and rigs developed for clarification of cell culture broths blocked rapidly when confronted with (milled) leaf homogenate (J.A.Purvis, personal communication). A vibrating sieve membrane was used as a substitute for the centrifugation step (there carried out in a bucket centrifuge of 6 x 1 L capacity). It was reportedly simple, cleanable and delivered equivalent to pre-filtration quality material very quickly (H.A. Young, personal communication); it cost £5k. A vibrating filter rig from Pall did not perform well on loan; it cost £40-60k.

Precipitation is a common early processing step, occurring in 81% of the plant protein purification methods surveyed (compared to 57% for the purification of non-plant proteins) (Jervis and Pierpoint, 1989). Precipitation purifies and concentrates in a single step, for a variety of products in both small- and large-scale operations, and is inexpensive. The desired protein may be precipitated as an insoluble but active, or easily reactivated form, or the impurities may be brought down leaving the product in solution. The scale up of precipitation relies on efficient use, cost and availability of the bulk chemicals required, and a standard mixing set up, whether batch stirred tank or continuous junction pipe.

Such procedures can be complemented by selective denaturation of unwanted proteins. Heat treatment may be suitable, if the desired protein is heat-stable, while endogenous proteases are inhibited effectively to avoid rapid proteolysis.

Crudely extracted in sap, wild type CPMV retains infectivity after heating to 55-65°C for 10 min, and for a few days' storage *in vitro* (de Jager, 1980). Heat at 50-60°C coagulates the chloroplast fraction only of leaf extracts; at 75-80°C, more soluble plant proteins are brought down. Overall, heat coagulation by steam injection of unfractionated (pressed and pulped) extracts is recommended, because the intense local heating is economic and results in a readily filtered product (Pirie, 1971a). With an overlapping range of temperature activity for virus and protein, this appears to be an unsuitable technique for complete separation. It might be combined with chemical precipitation, for instance, to remove the chloroplast fraction.

2.4 Research Aims

This study sought to develop a biochemical engineering framework using scale-down techniques to collect data to use to predict large-scale performance, in establishing process options for the initial extraction and recovery of plant virus vaccines based on CPMV. Each process run was designed to require only a single leaf's worth of starting material. Unit operations evaluated were those already commercially available for large scale processing. The wild type CPMV was used initially as a model for future variants, which were not available at the start of the project. Finally, process recommendations based on wild type performance were applied to the extraction and recovery of a recombinant vaccine candidate based on CPMV, and the results compared to those obtained for the wild type.

3. Materials & Methods

"This poster should contain no more than eight words, which is the maximum the average reader can take in at a single glance. This, however, is a poster for Economist readers." (Anon., 2000)

3.1 Guiding Principles

Since the quantity of recombinant material available for research and development use was very limited, it was decided to process on a sufficiently small scale for rapid evaluation of process alternatives. The unit operations chosen for testing were only those which were already commercially available for large scale processing. Storage at -80°C was used to simplify scheduling and minimise degradation of the feedstock. Frozen leaves were crushed before being introduced into the scale-down disruption equipment: this pretreatment would not be necessary on a larger scale. Fresh leaves were compared with frozen, after being pre-sliced into similarly sized pieces. For disruption, a high-shear homogeniser was used on a batch basis, with a processing time of between five seconds and eight minutes. A bead mill was also tested. Centrifugation was used for clarification of the homogenate and separation of precipitates: volumes of 1-25 ml were processed in fixed-angle rotors whose performance can be related to production models by standard theoretical and empirical relationships. Precipitation with ammonium sulphate and with polyethylene glycol (PEG) was tested, again in 1-25 ml volumes.

The final aim for scale-down work was to be able to take just one infected leaf (2 g) and from this, test an entire extraction and recovery process. Minimum working volumes of 1-7 ml were used in the unit operations investigated, starting with only 2 g of leaf. Of course, the problem then rolls over into finding a representative single leaf!

3.1.1 Chemicals and Reagents

All chemicals used were analytical grade from Sigma-Aldrich Company Ltd (Poole, UK) or Merck Ltd/BDH Laboratory Supplies (Poole, UK), except where stated otherwise.

3.1.2 Containment

Work carried out involved use of a naturally occurring plant pathogen, regulated by MAFF, and genetically modified micro-organisms (GMM) based on it which retained the capacity to cause disease in plants, classified as Group II (ACDP, 1995). Type A operations (non-industrial; small-scale) (HSE, 1996) were carried out using both types of CPMV. [Also see section 11.6, Safety, on page 150.]

Solutions known or suspected to contain virus were decontaminated with Virkon (Day-Impex Ltd, Earls Colne, UK) used at 1% v/v for 0.5-1 h according to the manufacturer's directions. Stainless steel parts were soaked for the shorter period to minimise corrosive damage. During processing tightly wrapped thin film polythene membranes were used to limit aerosolisation of virus particles. The laboratory in which processing was carried out was designed and operated at laboratory containment level 3 (ACDP, 1995) with restricted access, adherence to agreed SOPs and site safety rules, negative/positive air pressure control and HEPA (high efficiency particulate absorption) filtration of exhaust air before discharge to the environment. Waste solids not containing CPMV or containing CPMV decontaminated with Virkon were incinerated on site at UCL; solids containing untreated CPMV were double-bagged and sealed within the lab, autoclaved within the building, then incinerated as above.

3.2 Plant Growth, Infection and Harvest

Leaves were provided to UCL courtesy of Axis Genetics (formerly of Babraham, UK). Cowpea plants, *Vigna unguiculata* (L.) Walp. cv. 'Blackeye', were grown in contained controlled-environment chambers (24°C, 16 h daylength), inoculated by hand with wild type CPMV particles on the first true leaf pair, and all subsequent fully expanded leaves harvested individually approximately three weeks (19-27 d) post-infection (Table 1). A production density of 100 plants or 1 kg leaves m⁻² was achieved. Leaves were gathered into a polythene bag and kept in ambient conditions for approximately 1 h, then frozen in bulk directly at -80°C, transported from Cambridge to London on dry ice and stored for up to three years. Each quantity processed may have contained mixed leaves of various individuals from the same growth batch.

Table 1. CPMV-infected plants' growth batch designations.

Axis batch designation	New batch number	Harvest DPI	Harvest date
WT-30	1	23	20.11.97
WT-33	2		23.12.97
WT-38	3		16.02.98
WT-40	4	27	11.05.98
WT-41	5	19	10.06.98
WT-44	6	19	03.08.98
WT-47	7	20	07.09.98
WT-49	8	21	26.11.98
WT-50	9	21	15.12.98
WT-52	10	19 fresh, 22 frozen	29.03.99, 01.04.99
muc14-41	11	26	28.09.98
muc14-52	12	16	23.12.98
mast14-9	[not used]	22	07.05.99
muc14-54	13		10.06.99

WT, wild type CPMV; *muc14*, CVP with mucin epitope insertion; *mast14*, CVP with mastitis epitope insertion; *DPI*, days post-infection (where known). Uninfected leaves were not distinguished by batch.

3.3 Extraction

3.3.1 Freeze-thaw

Frozen leaves were crushed by hand (day-old fresh leaves were sliced into equivalent size pieces with a scalpel), then 5 ml of Tris-HCl buffer 0.3M, pH 7.0 (Tris buffer) added to 2 g of leaf in a 25 ml glass universal bottle. For freeze-thaw experiments, alternative solutions of reverse osmosis-purified (RO) water and sodium citrate buffer 0.5M, pH 6.0 were also used, and the mixture allowed to stand for up to 1 h at ambient temperature or overnight at 4°C.

3.3.2 Blending

In the standard method of Klootwijk et al. (1977), fresh leaves are disrupted in two millilitres of 0.1M phosphate buffer per gram of leaf in a Waring Blendor (Waring, New Hartford, CT, USA) to furnish an initial extract. Here, frozen leaves (weight taken as fresh weight) were blended in Tris buffer.

3.3.3 Batch Homogenisation

Frozen leaves were crushed by hand (day-old fresh leaves were sliced into equivalent size pieces with a scalpel), then 5 ml of Tris buffer added to 2 g of leaf in a 25 ml glass universal bottle. For freeze-thaw experiments, alternative solutions of RO water and sodium citrate buffer 0.5M, pH 6.0 were also used, and the mixture allowed to stand for up to 1 h at ambient temperature or overnight at 4°C. The mixture was homogenised for 1 min at the maximum speed of 15 000 rpm using a Silverson Lab SL2 with 16 mm slotted head aggregate (5/8" Micro Tubular Mixing Assembly with Integral Open-ended, Vertical Slotted Disintegrating Head, Silverson Machines Ltd, Chesham, UK). The high speed rotor-stator configuration of the Silverson mixer-emulsifier (Figure 2) disintegrated and maintained a suspension by a combination of successive suction, milling, high-shear and mixing actions. During processing in 20 ml universal bottles (ID 22 mm), the unaerated total fluid volume was 6.8ml, and a gap of at least 6 mm was maintained between the aggregate and the base of the container; when processing in 100 ml Duran bottles (ID 48 mm), the unaerated total fluid volume was 68 ml, and the floor clearance ≥ 7 mm.

Versions of the machine are available as batch mixers or continuous in-line pumps up to the largest industrial sizes (30 000 L batch or 200 000 L h⁻¹ continuous throughput (Silverson leaflet, High Shear In-Line Mixers, 1997 version) allowing scale-up based on the same disruption principle.

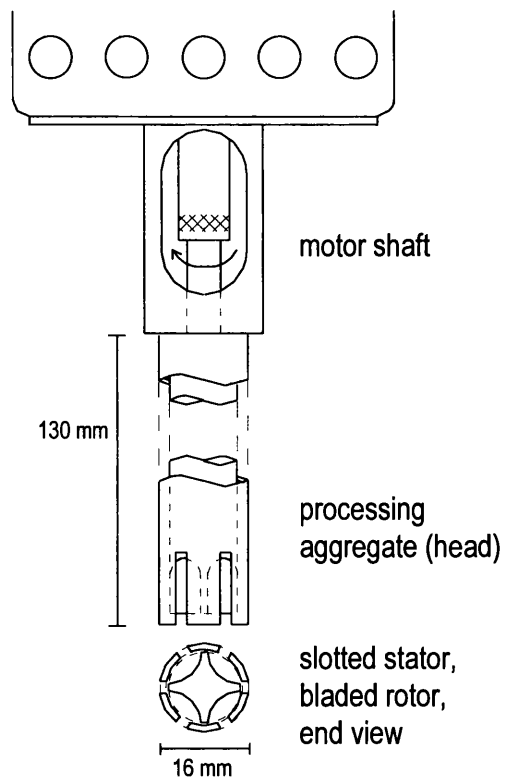

Figure 2. The Silverson batch homogeniser.

To scale.

The batch homogeniser used had a rated power of 75 W, a processing head diameter of 12 mm, a nominal maximum speed of 9000 rpm (but see later measurements), and a blade tip speed of approximately 7 m s^{-1} .

3.3.4 Continuous Homogenisation

The pumping chamber of the smallest available in-line Flash Mix Silverson homogeniser (Figure 3) (Silverson Machines Ltd, Chesham, UK) was first primed by allowing RO water to flow through it in the reverse direction to pumped flow. Frozen leaves of batch 5 or uninfected leaves were crushed by hand and 20 or 40 g (a dilution of 1/10 or 1/20 compared to batch homogenisation) poured into 1 L of Tris buffer in a 5 L beaker and processed immediately. The mixture was homogenised at the minimum speed of 3500 rpm (20 L min^{-1}), measured by an integral digital tachometer. The maximum operating speed for this machine was 10 500 rpm in air (although it should not be run dry, any air entrained in the process fluid would lower its viscosity and therefore raise the operating speed towards this value). The residence time was calculated to be 0.066 s per pass at 3500 rpm, by straight-line extrapolation from dye tracer measurements between 0-3000 rpm assuming plug-flow (J. Martin, personal communication). Processing temperature was not controlled.

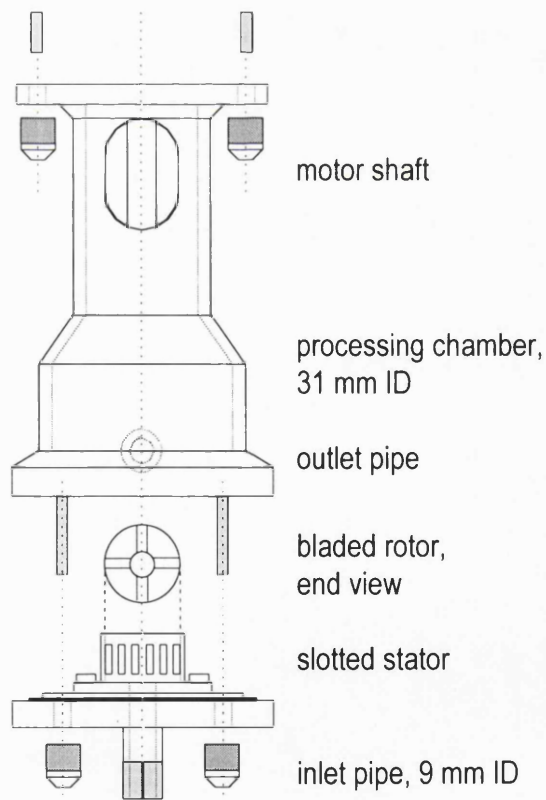

Figure 3. The smallest scale-down continuous Silverson high shear homogeniser.
Side view, partially exploded. ID, internal diameter.

3.3.5 Bead Milling

Twenty grams of leaves were homogenised in 50 ml of Tris-HCl buffer in a 100 ml Duran bottle for 1 min, then pumped into a 0.6 L (continuous) or poured into a 0.15 L (batch) glass chamber bead mill fitted with polyurethane blades and 85% filled with 1.5 mm leadfree glass beads (Dyno-Mill, Glen Creston Ltd, Stanmore, UK). Milling was carried out for 1 min at 3200 rpm, with cooling by iced water circulation in the jacket. The theory and application of bead mill disruption is described elsewhere (Limon-Lason *et al.*, 1979). The model used can be completely disassembled for cleaning of the contact surfaces. The risk of aerosolisation has led, in industry, to enclosed use in soft film cabinets in low containment processing areas. Bead mills are now available up to 275 L capacity capable of processing a 2000 kg h⁻¹ throughput containing 340 kg h⁻¹ DW [yeast cells].

3.3.6 Shear Device

The design and operation of the scale-down rotating-disk shear device is described in detail elsewhere (Levy *et al.*, 1999; Boychyn, 2000). It consists of a 40 mm ID, 10 mm high cylindrical processing chamber with a central rotating disk 1.5 mm thick and 30 mm diameter, giving a fluid volume when full of $1.15 \times 10^{-5} \text{ m}^3$. The hydrodynamics can be modelled from first principles for simple fluids and the known range of shear, γ or \bar{G} , developed is from 19 000 s⁻¹ to 350 000 s⁻¹. The maximum velocity in the process fluid is in the boundary layer at the edge of the rotating disk, and the maximum shear is developed at the outermost top and bottom edges of the disk.

3.4 Assays

3.4.1 Sample Storage

Samples were stored at 4°C undiluted and unclarified with added 0.05% sodium azide, and assayed after 0-1 and 1-2 d for CPMV and protein respectively. There was no significant difference in the total amount of CPMV (or protein) measured in samples of unclarified homogenate stored in the Coldroom at approximately 4°C for between 5 min and 25 h before loading the dilutions onto the assay plate (Figure 4) (11.05.99).

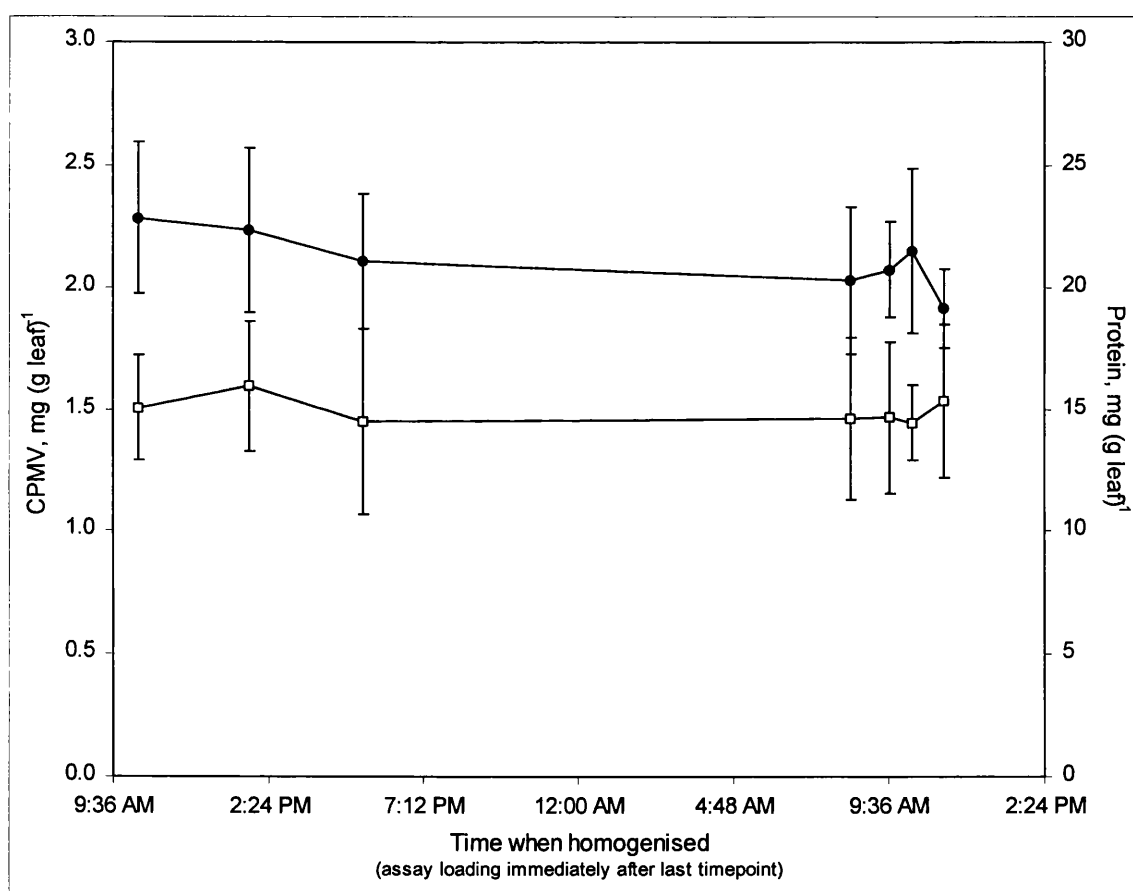

Figure 4. Effect of assay loading delay on measured virus and protein contents.

CPMV, ● ; protein, □.

3.4.2 Spectrophotometry

Spectrophotometry was performed in a Dynatech MR7000 with platereader and EIACALC software (Dynex Technologies, Billingshurst, UK) using 405 nm and 750 nm filters for ELISA and protein assays respectively.

In addition the ratio of absorbances at 260 nm and 280 nm (OD_{260}/OD_{280}) measured in a Kontron Uvikon 922 (Kontron Instruments, Watford, UK) was used to determine the CPMV content of purified samples known or assumed to contain CPMV only, with no extraneous protein

or nucleic acid. At OD₂₆₀ a reading (extinction coefficient) of 8 corresponded to 1 mg ml⁻¹ of virus in the buffer solution, for a cuvette path length of 1 cm (van Kammen, 1967). The virus sample was typically diluted by 250× in order to bring the reading into the linear response range of the spectrophotometer (T.D. Jones, personal communication).

3.4.3 ELISA

A double antibody sandwich non-competitive enzyme-linked immuno-sorbent assay (DAS-ELISA) performed in antibody-binding polystyrene Microtiter® plates, Immulon-4HBX (3855, Dynex Technologies, Billingshurst, UK) with the monoclonal antibody 10B7 (Porta and Wang *et al.*, 1994) detected wild type CPMV or recombinant CVPs at 20-200 ng ml⁻¹ in 1/1000 - 1/40000 dilutions of process samples. Assay precision was 15%. Wild type and muc14-CPMV standards were provided by Axis Genetics (formerly of Babraham, UK). The plate layout was as shown (Figure 5).

	1	2	3	4	5	6	7	8	9	10	11	12
A	S1	S1	b	b	T4	T4	T12	T12	T20	T20	T28	T28
B	S2	S2	b	b	T5	T5	T13	T13	T21	T21	T29	T29
C	S3	S3	b	b	T6	T6	T14	T14	T22	T22	T30	T30
D	S4	S4	H	H	T7	T7	T15	T15	T23	T23	T31	T31
E	S5	S5	M	M	T8	T8	T16	T16	T24	T24	T32	T32
F	S6	S6	L	L	T9	T9	T17	T17	T25	T25	T33	T33
G	S7	S7	T2	T2	T10	T10	T18	T18	T26	T26	T34	T34
H	T1	T1	T3	T3	T11	T11	T19	T19	T27	T27	T35	T35

Figure 5. Template for ELISA.

S1-S7, CPMV standards; b, buffer blank; H,M,L, high, medium and low controls; T1-T35, samples diluted for testing.

3.4.4 Total Protein

Total protein, representing main host contaminants but including viral material, was measured against a bovine serum albumin (BSA) reference standard diluted to 20-200 $\mu\text{g ml}^{-1}$ in a dye-based microplate assay (Protein Assay Kit II, BioRad, Hemel Hempstead, UK) of samples at 1/10 - 1/320 dilution. Assay precision was 5%. The protein content of purified virus samples tested by protein assay against the BSA standard agreed with the virus content, within experimental error. The plate layout was as shown in Figure 6.

	1	2	3	4	5	6	7	8	9	10	11	12
A	S1	S1	b	b	T5	T5	T13	T13	T21	T21	T29	T29
B	S2	S2	b	b	T6	T6	T14	T14	T22	T22	T30	T30
C	S3	S3	b	b	T7	T7	T15	T15	T23	T23	T31	T31
D	S4	S4	H	H	T8	T8	T16	T16	T24	T24	T32	T32
E	S5	S5	M	M	T9	T9	T17	T17	T25	T25	T33	T33
F	S6	S6	L	L	T10	T10	T18	T18	T26	T26	T34	T34
G	T1	T1	T3	T3	T11	T11	T19	T19	T27	T27	T35	T35
H	T2	T2	T4	T4	T12	T12	T20	T20	T28	T28	T36	T36

Figure 6. Template for protein assay.

S1-S6, CPMV standards; b, buffer blank; H,M,L, high, medium and low controls; T1-T36, samples diluted for testing.

3.4.5 SDS-PAGE

Denaturing sodium dodecyl sulphate polyacrylamide gel electrophoresis (SDS-PAGE) was carried out as described (Sambrook *et al.*, 1989) in 12.5% acrylamide main gels, which were stained with Coomassie Brilliant Blue R250 (Sigma, Poole, UK) and digitally photographed (UVP transilluminator, digital camera and ImageStore5000 software, Ultra Violet Products Ltd, Cambridge, UK). The CPMV standard was loaded at 2 μ g per lane. Details of marker proteins (Low Molecular Weight Calibration Kit, Amersham Pharmacia Biotech, Little Chalfont, UK) are given in Table 2.

Table 2. Details of molecular weight markers used in SDS-PAGE.

Protein	Subunit molecular mass, kDa	μ g loaded per lane (8 μ l aliquots)
phosphorylase b	94	2.68
albumin	67	3.32
ovalbumin	43	5.88
carbonic anhydrase	30	3.32
trypsin inhibitor	20.1	3.20
α -lactalbumin	14.4	4.64

SDS is a strongly anionic detergent which binds to proteins unfolded by boiling, wrapping them in an overwhelmingly negative charge. Subsequent separation in the gel, under the motive force of an electrical potential, against the hindrance of a gel matrix, depends therefore on apparent molecular weight rather than pre-existing charge on the various protein molecules or subunits, providing a straightforward way of comparing many different protein moieties in one array.

3.4.6 Particle Size Measurement

A laser reflectance particle sizer 3D-ORM and associated software (MessTechnik Schwartz GmbH, Düsseldorf, Germany) was used to assess particle distributions within the size range 0.5-250 μ m. Samples of 1-2 ml were diluted to 16 ml then stirred continuously during measurement.

A Mastersizer2000 with Hydro SM attachment (Malvern Instruments, Malvern, UK) was used for particle size determination of samples from batch and continuous homogenisation. Samples were dispersed in 50-100 ml RO water previously degassed by overnight exposure to atmospheric pressure. [Parameters used: optical properties, default irregular; result calculation algorithm, general purpose; obscuration limits, 10-15%; stirrer speed, 2000-2500 rpm; measurement time, 4 s; grabs per signal, 4000; replicate measurement signals, 3.]

Distributions by number were derived from measurements by volume (calculated from cross-sectional areas assuming roughly spherical particles), by the particle sizer software.

3.4.7 Dry Weight

Dry weight was noted after drying in a fan oven for 24 h at 100°C.

3.4.8 Light Microscopy

A Nikon Optiphot (Nikon, Kingston, UK) was used with 10× eyepiece and 100× oil immersion objective lenses for direct observation of diluted leaf homogenate.

3.4.9 Electron Microscopy

For transmission electron microscopy (TEM), fresh and frozen leaf strips 1mm wide were fixed in 2% glutaraldehyde under vacuum, post-fixed in osmium tetroxide, stained with uranyl acetate, dehydrated in a graded alcohol series and embedded in Araldite resin. Visualisation was carried out but results were inconclusive and not shown here. For scanning electron microscopy (SEM), unfixed leaf tissue was frozen under liquid nitrogen, freeze-fractured *in situ*, the water sublimated off and visualised using a Philips XL30 FEG SEM with cold stage LT 7400 (FEI UK Ltd, Cambridge, UK).

3.4.10 Rheometry

A Contraves Rheomat 115 with cup-and-bob attachment DIN 145 (Contraves Industrial Products Ltd, Ruislip, UK) was used to characterise the behaviour of leaf homogenate suspension under moderate shear stress of 200-600 mPa and shear rates of 10-1000 s⁻¹. Speed steps up or down in logarithmic progression were made approximately every minute in three complete cycles.

3.4.11 pH and Ionic Strength

Ionic strength, % saturation and molarity were calculated during reagent preparation. Final pH measurements were made directly at the intended temperature of use of buffers (Mettler Delta 340 or Mettler-Toledo MP220, Mettler-Toledo Ltd, Leicester, UK).

3.4.12 Density

Homogenate density was determined using a buoyant hydrometer (model 1000-1050, BDH, Poole, UK).

3.5 Precipitation

3.5.1 Ammonium Sulphate

Processing was at pH7 (Klootwijk *et al.*, 1977). Ammonium sulphate was made up in Tris buffer to a final precipitant molarity of 3.6M or added as solid crystals. The precipitation mixture (volume 1-32 ml) was then shaken overnight on a vibrax shaker (IKA-VIBRAX-VXR Typ VX 2E, Janke & Kunkel, distributed by Fisher Scientific, Loughborough, UK) for 17-24 h. After precipitation, low speed centrifugation as above was used to separate the supernatant from any precipitate and other solid fraction material. Measured concentrations or yields refer to supernatant, except where stated; solids were resuspended in buffer before sampling. This supernatant was used as the starting material for a second cut, where ammonium sulphate was added as before. The supernatant from the first cut contained a residual amount of ammonium sulphate. Additional ammonium sulphate was added for the second cut to calculated final molarities stated as if the original fluid contained no ammonium sulphate. After low speed centrifugation as before, the precipitate was resuspended in Tris buffer. Concentrations of CPMV and total protein in supernatant or resuspended-solids solutions were given corrected to the original volume of starting material (clarified or whole homogenate) before the addition of precipitant. This corrected for dilution due to any added volume of precipitant or resuspension buffer.

3.5.2 Polyethylene Glycol

Polyethylene glycol (PEG), molecular weight 8000 (Sigma, Poole, UK), was made up in 1M NaCl, pH7 to stock molarities between 0-50%. 0.5 ml of each (pH 6.9-7.3) was then added to 0.5 ml of clarified homogenate (pH 6.5-6.8) to make final mixtures between 0-25% PEG in 2.2 ml eppendorf tubes. These were shaken at 1400 rpm for one minute then at 150 rpm for 1 h at ambient temperature on a vibrax shaker as before. After precipitation, low speed centrifugation as above without external cooling was used to separate a supernatant from any precipitate and solids. After low speed centrifugation the precipitate was resuspended in Tris-HCl buffer. Concentrations, in mg ml⁻¹, of CPMV and total protein in supernatant or resuspended-solid solutions, were corrected to the original volume of starting material (e.g. clarified homogenate) before the addition of precipitant.

3.5.3 Centrifugation

Low speed centrifugation at 5000 g, or average relative centrifugal force (RCF), was carried out as described above either in 2.2 ml eppendorf tubes in a fixed angle rotor, Biofuge 13 (Heraeus

Sepatech GmbH, Osterode, Germany) or Micro Centaur (MSE Scientific Instruments, Crawley, UK); or in 50 ml centrifuge tubes in a fixed angle rotor cooled to 4°C, Beckman J2-M1 with rotor JA-17 (Beckman Coulter Bioresarch, Beckman Coulter (UK) Ltd, High Wycombe, UK).

3.5.4 Filtration

Preliminary process work carried out to Axis' directions used dead-end membrane filtration for polishing of the supernatant from precipitation. 0.45 and 0.2µm pore size polysulphone (PS) filters (47 mm, Supor, Gelman Laboratory Ltd, Northampton, UK) were used in series.

3.6 Statistical Treatment of Data and Errors

3.6.1 Presentation of Data

Yields on a mass basis (mg g⁻¹) were given in terms of milligrams of detectable CPMV or soluble protein per gram of fresh or frozen (wet weight) cowpea leaf. Percentage yields (%) on a mass basis were calculated using unrounded values, and (except where otherwise stated) were with respect to 100% in whole homogenate.

Concentrations (mg ml⁻¹) of CPMV and total protein in supernatant or resuspended-solids solutions after precipitation were given corrected to the original volume of starting material (either clarified or whole homogenate) before the addition of precipitant. This corrected for dilution due to any added volume of precipitant or resuspension buffer.

Error bars showed ±1 standard deviation of at least 3 replicates.

3.6.2 Purification Factors

Purification factors were used to describe the change in the ratio of CPMV to total protein through the process, comparing the conditions at the stage fraction of interest (e.g. in the second cut solids) to those in the original homogenate:

$$PF = (\text{CPMV/total protein})_{\text{stage fraction}} / (\text{CPMV/total protein})_{\text{homogenate}}$$

Where CPMV accounted for a non-negligible fraction of the final total protein, net purification factors were calculated using net protein instead of total protein, where net protein = (total protein - CPMV).

4. Assay Development

“All numbers merely reflect the accuracy of existing technologies, but more than that, they are always embedded in a snarl of intellectual presuppositions.” (Strauss, 1995)

Without methods of detection, nothing can be deduced from the manipulation of any experimental variable. For each assay, it must be unambiguously stated what it detects and between which related species it differentiates, with known, relevant points of reference spanning the detection range. Assay development work was undertaken in order to improve the efficiency of the assays used, and better understand their limitations.

4.1 ELISA

4.1.1 Description of Assay

Enzyme-linked immunosorbent assay (ELISA) was a convenient method of specifically and quantitatively identifying an antigen in many, impure, dilute samples at once. It was performed with very small volumes of reagents in a 96-well Microtiter® plate (Immulon 4HBX, Dynex Technologies, Billingshurst, UK) and read electronically by a spectrophotometer at a single wavelength of 405 nm (green). Samples at 1/10000 to 1/80000 dilution in phosphate buffered saline with 0.05% Tween (PBST) were calibrated against a standard curve of 20 to 200 ng ml⁻¹ CPMV freshly prepared and incubated on the same plate. All incubation steps were carried out for 1 h at 37°C with 100 rpm orbital shaking, except the first (overnight at 4°C with no shaking) and the last (15 min only). Volumes of 100 µl per well were used for reagents and 200 µl for washing and blocking. Between steps, the plate was washed with PBST and shaken dry. (PBST, although meant to be pH 7.0, was often pH 7.5-8.0.) (For the precise technique, see the example standard operating procedure (SOP) in section 11.3.1 on page 137.)

Double antibody sandwich detection of the antigen was used. Although commercial kits were believed to be available for the detection and identification of the plant pathogenic CPMV, they were not quantitative.

Various monoclonal (single site specific) and polyclonal (multiple epitope recognition) antibodies have been raised against the naturally occurring CPMV and recombinant constructs based on it. A polyclonal sheep anti-CPMV (L123, Axis Genetics, formerly of Babraham, UK) was precoated on the test plate in the first step. A dilute solution of protein in the form of spray-dried skimmed milk (Tesco, Cheshunt, UK) was next added, to block any remaining protein-binding sites on the plate. Samples were then loaded (in dilute form, to avoid saturating the

binding sites), and the CPMV present was trapped from free solution by the coating antibody. 10B7, a monoclonal raised in mouse (Axis Genetics, formerly of Babraham, UK), binds to the wild type CPMV at a single site between its S and L capsid subunits. It was applied next, to 'sandwich' and thus amplify the response to each bound antigen. A commercially available rabbit anti-mouse immunoglobulin pre-conjugated with horseradish peroxidase (P0260, DAKO, High Wycombe, UK) was bound in the penultimate step, and catalysed a visible colour change in the final substrate solution of ABTS (A9941, Sigma, Poole, UK) in citric acid activated with hydrogen peroxide (101284N, BDH, Poole, UK).

The template comprised several standards and three controls in duplicate, blanks (of which six were averaged per plate), and samples in duplicate.

The brand of microwell plate used was specially designed to bind antibody, which must coat to excess relative to the number of virus particles to be detected. Each coating antibody in the correct orientation can then bind one (much larger) CPMV particle from the solutions applied. One CPMV particle (concentration-limiting), in turn, binds many monoclonal antibodies in the following step (proportional amplification). Each of these monoclonals binds one conjugate antibody. Each conjugated enzyme catalyses many ABTS oxidations (proportional amplification again).

The amplification step monoclonal antibody 10B7 has been found to be particularly sensitive to storage conditions. It appears to lose activity on freezing at -80°C [long term storage] and regain it partially over months at 4°C . At various times, for one batch $1/80000$ was recommended but only $1/8000$ gave a satisfactory result. The next batch likewise required a tenfold increase from $1/12000$ to $1/1200$. It might exist partly as a reversibly aggregating monomer, dimer, or trimer, which with increased free 10B7 surface on disassociation might amplify the response per virus particle still further.

4.1.2 Standards and Controls

The CPMV standards were purified preparations quantified by spectrophotometric absorbance at 260 nm (A_{260}). The A_{260} is related to the dried weight of virus, such that (for a 1 cm path length in solution in the cuvette) an A_{260} of 1.0 at 1/50 dilution corresponds to 8 mg ml⁻¹ in the original solution (van Kammen, 1967). The range of on-plate standards (Table 3) was chosen to give a maximum spectrophotometer absorbance reading of about 1.0 before subtraction of blank.

ELISA is precise (tightly clustered results) but not accurate (true values not yet assigned) because the absorbance quantitation is neither specific to CPMV nor precise in comparison to other sources of error in the assay.

Table 3. Standard and control concentrations routinely used in ELISA.

Standard or control	S0	S1	S2	S3	S4	S5	S6	S7	S8	H	M	L
CPMV concentration, ng ml ⁻¹		200	150	100	75	50	25	10	0	80	50	15
	250	200	150	100	75	50	25	10	0	100	50	10
		212	186	160	134	108	81	54	27	186	108	54

S0-S8, standards; H, M, L, high, medium, and low controls.

4.1.3 Plates

A cheaper flat-bottomed, 96-well microwell plate (Sarstedt Ltd, Leicester, UK) was tested but found not to give any colour development at all, whereas the Immulon-4HBX brand did (12.02.98). Since all other steps were independent of plate binding, the first (coating, polyclonal) antibody must not have bound to the alternative substrate polystyrene.

4.1.4 Washing

The method of washing (by multipipette 200 μ l per well thrice with PBST buffer) was satisfactory, but the blocking step (with reconstituted 5% skimmed milk protein) was also necessary: wells left unblocked did develop slight colour even in the absence of antigen (03.03.98).

4.1.5 Conjugates

A very high blank of 1.3 (dark green) arose when using a more readily available, alternative conjugate antibody (rabbit anti-mouse-IgG (whole molecule) peroxidase A9044, Sigma, Poole, UK) at 1/1000 as recommended for Axis' reagent (rabbit anti-mouse immunoglobulins (polyclonal antisera) HRP conjugate P0260, DAKO, High Wycombe, UK) (26.02.98, 05.03.98). A side-by-side conjugates comparison at Axis of Axis' DAKO 1/10000 with UCL's Sigma 1/10000, also the latter at 1/40000 (manufacturer's recommended) and 1/80000 dilutions, gave results (A_{405} in OD units) for the top standard S1 (200 ng ml⁻¹) of 1.034, 0.988; 1.434, 1.422; 0.123, 0.124; 0.052,

0.054 respectively (06.03.98). Hence a dilution of between 1/1000 and 1/40000 for the Sigma conjugate would be required. Dilutions ranging from 1/1000 to 1/20000 were used subsequently (09.03.98), but results were inconclusive as no gradation of standards was apparent with this reagent (09.03.98, 13.03.98). Compared directly with the DAKO conjugate, dilutions of the Sigma conjugate between 1/2000 - 1/6000 gave very low standards readings, such as S1 (200 ng ml⁻¹) of 0.048 (11.03.98). The indicated Sigma conjugate concentration was 1/10000 although the maximum standard concentration attainable in any case was only 0.131 (13.03.98). Therefore it was not possible to obtain the desired response range with this antibody preparation.

Consequently a DAKO conjugate was obtained, of the same batch as that supplied to Axis, with a long shelf life at 4°C.

A crossreaction of the Sigma conjugate directly with the coating antibody L123 in the absence of detection antibody 10B7 was also observed (visibly green but unquantified) (13.03.98). This condition would not occur during normal ELISA testing as the intermediate antibody 10B7 serves both reaction-detection and blocking functions.

4.1.6 Standards

A new CPMV stock solution calculated to be of comparable strength was made from a separate stock of purified CPMV kept at 4°C, as the original CPMV stock had become degraded during storage at -80°C (13.03.98). Correlation between this new and the old standards was attempted. The standards made in polystyrene bijoux from new stock apparently retained only approximately 16% (range: 4-24%) of their intended values (25.03.98). This may have been due to storage at -80°C for two months (12.01.98-12.03.98), transportation on dry ice once (12.01.98), or the thawing process (12.03.98). Likewise, only about 20% of original activity remained for standards prepared similarly from another aliquot of the original stock which had been stored at -80°C (27.03.98). Axis archived duplicate process samples at this temperature, at which they were thought to be stable. Standards prepared as usual in 7 ml bijoux were made up in 1×, 2× and 3× strengths. Normal strength preparations of S1 (200 ng ml⁻¹) read up to 0.4 (A₄₀₅ in OD units); 3× S1 up to 0.5 only (01.04.98). It seemed that many times stronger standards would be required to achieve the desired readings.

CPMV concentrations from 164 to 5000 ng ml⁻¹ were made up in polypropylene eppendorfs. Until that time, standards had been mixed in suitably sized rigid polystyrene bijoux. However, polystyrene microwell plates bound CPMV strongly enough to form the basis of a direct-binding ELISA assay in 1995 (T.D. Jones, personal communication). The mechanism was suggested to

be electrostatic attraction (R. Gopal, unpublished MSc thesis, 1995). The experiment using soft polypropylene eppendorfs finally gave a satisfactory standard response at around 212 ng ml⁻¹ (with a blank of 0.319), or approximately 0.9 (A_{405} in OD units) at 200 ng ml⁻¹ (Figure 7) (02.04.98). Therefore, previous underreadings were attributed to adsorption of the virus at the polystyrene plate walls. Calculations of the virus loss attributable to an adsorbed monolayer indicate that a maximum of 0.1-2% loss would be expected from standards containing 20-400 ng of CPMV in a bijoux tube 16 mm ID and 47 mm tall, assuming square packing and a wild type CPMV diameter of 28 nm. However, a further mechanism of aggregation at the wall surface would be capable of enhancing removal from solution to the levels seen.

Standards up to S0 (250 ng ml⁻¹) were also tested but the response was no greater and assumed to be near a plateau (08.05.98). Therefore only 200 ng ml⁻¹ needed to be used, as originally expected.

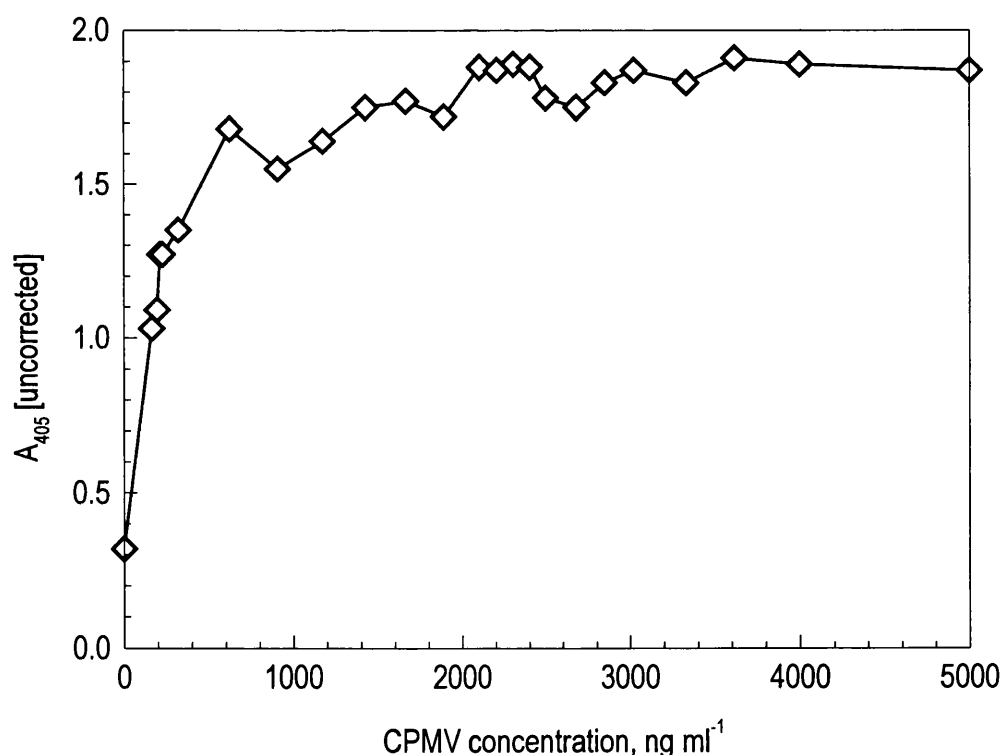

Figure 7. Absorbance response with increasing CPMV concentration.

A comparison between old standards S1-S8 and new Z1-Z8 showed the latter as only up to 157 ng ml⁻¹ predicted for the 200 ng ml⁻¹ equivalent, implying that the new preparation was only 2/3 of the original's activity (14.05.98). Repeated, this experiment gave the opposite result, in that Z1 and Z2 read high, mostly off scale but Z2 (150 ng ml⁻¹) of 196, for example, indicating that either the spiking standards are more concentrated than they are labelled or that the old stocks have deteriorated (03.07.98). Another recalibration was required when the CPMV stocks for preparing standards and controls again ran out. Standards freshly prepared from the original stock solution were compared with similar standards prepared one and two weeks previously and stored at 4°C, and standards freshly prepared from a new CPMV stock solution. Responses were similar (08.12.98). Although stock CPMV concentrations had been previously determined by A₂₆₀ measurements, the final responses in ELISA were slightly different (Figure 8) (02.04.98). A final conversion factor of 1.1× was confirmed by a polynomial fit line with r²=0.997 (old, 0.999; new, 0.997) and the straight-line correlation shown.

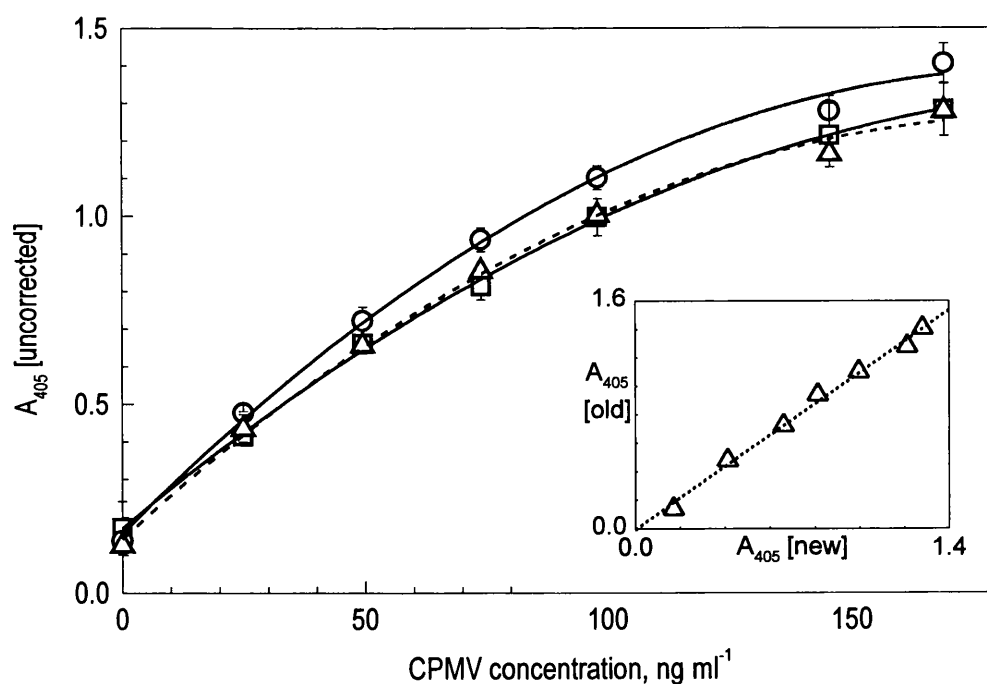

Figure 8. CPMV standards changeover calibration.

CPMV standards made from old (□, —) and new (○, —) stocks were related by a 1.1× conversion factor (Δ,).

A multiple comparisons test was carried out between old and new stocks of coating antibody L123; 1/6000 and 1/12000 dilutions of detection antibody 10B7; 1/500 and 1/10000 dilutions of conjugate antibody; and CPMV standard S1 dilutions freshly prepared from old stock, from new stock, and re-prepared from new stock (additional independent replicates). There was no difference between old- and new-L123 treated plates; therefore data from both were combined (Figure 9). For 10B7 dilutions, all readings (except one) at 1/6000 were above (range: 0.6-0.9) those for the 1/12000 dilution (range: 0.85-1.4), showing amplification of the assay response by 10B7. Increasing conjugate dilutions raised OD responses slightly. The different fresh standards were indistinguishable.

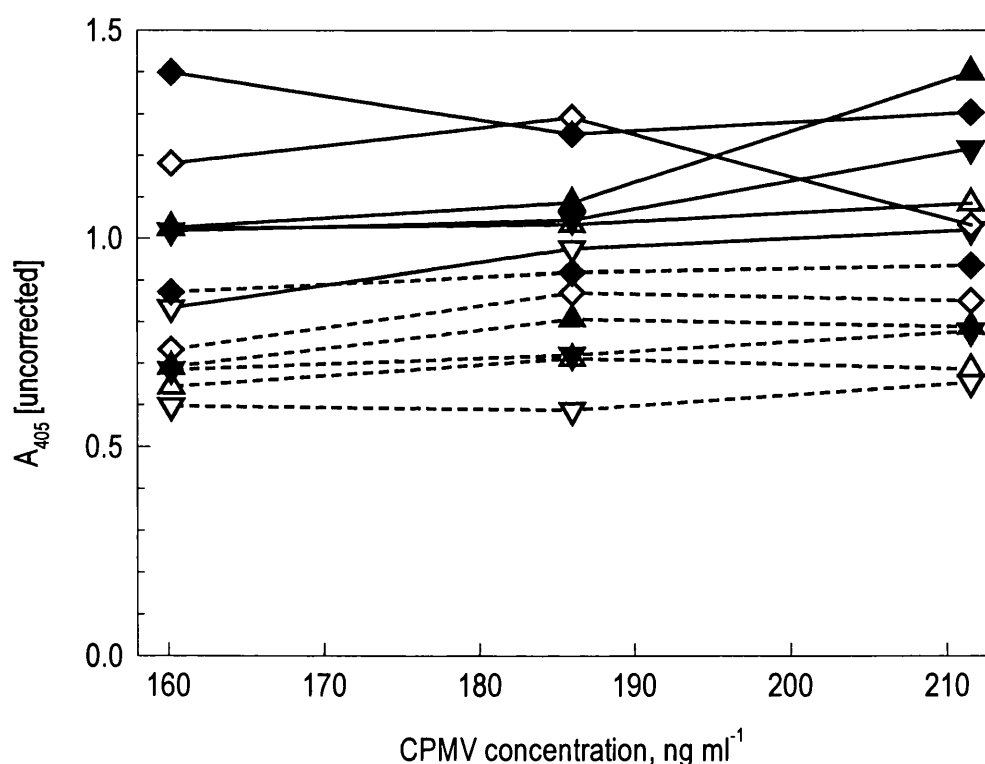

Figure 9. Multiple comparisons test.

10B7 1/12000, — ; 10B7 1/6000, - - ; conjugate 1/1000, open symbols; conjugate 1/500, solid symbols; freshly prepared from old CPMV stock, △, ▲; re-prepared from old CPMV stock, ▽, ▼; freshly prepared from new CPMV stock, ◇, ◆.

4.1.7 Blank Background

A blank reading was still too high at 0.466, whereas it was expected to be *circa* 0.1 OD units (02.04.98). If unwanted nonspecific 'crosstalk' was occurring between antibodies in nonadjacent layers, this would increase the background reading. This is precluded by the design of the assay. If non-CPMV proteins in the samples were erroneously being recognised by the detection antibody, background readings would again be too high. To precipitate non-CPMV antigen, samples were pretreated with sheep serum 1% (S-3772, Sigma, Poole, UK), incubated for half an hour and centrifuged (08.05.98). Little if any precipitate was observed and no difference was evident in the final readings. Wells with no coating antibody, no detection antibody, but blocked and with conjugate, gave a blank of 0.257 which was still too high (01.04.98). It was later realised (in the protein assay) that this was due to the cover strip, attached for containment purposes, not being removed for platereading. Correcting this procedure solved the high blank problem.

4.1.8 Detection Antibody

The monoclonal detection antibody, 10B7, amplified the assay response to each bound antigen particle. Although the recommended dilution of the Axis aliquots used was 1/80000, 1/8000 was used once and S1 readings of 1.0 were obtained (15.05.98), compared to 0.3-0.4 in the previous experiment (14.05.98). This happened to be the last remaining of that particular batch, but the result illustrated the sensitivity of the ELISA to this step in particular. For the new batch of 10B7, a working dilution of 1/12000 was recommended. An initial test specifically for the most appropriate dilution of 10B7 therefore used 1/1000 to 1/11765 dilutions with representative standards S1 (200 ng ml⁻¹) and S2 (150 ng ml⁻¹). The (acceptable) blanks of 0.157-0.178 varied little with 10B7 concentration. Corrected S1 readings were 1.1-1.2 for the 1/1000 dilution and 0.8-1.0 for the next least dilute, 1/1667 (26.06.98). Corrected readings of around 1 are desirable, although because of the blank of 0.1-0.2, this does mean that the spectrophotometer must detect uncorrected readings greater than 1.0. A new shipment of 10B7 tested between 1/1500 and 1/12000 again gave little difference between blank readings (14.10.98). Freshly made and day old standards were used: typical readings for S1 (200 ng ml⁻¹) of 1.2-1.3 with the previous 10B7 were most closely matched by the replacement 1/6000 dilution (14.10.98). The closest to the desired 1.0 was actually the recommended 1/12000, at 0.9-1.0 (14.10.98). An assay using this dilution gave acceptable S1 (200 ng ml⁻¹) readings of 1.1 (15.10.98). Later data showed an increasing response with dilutions of 10B7 up to 1/1000 (Figure 10) (29.04.99).

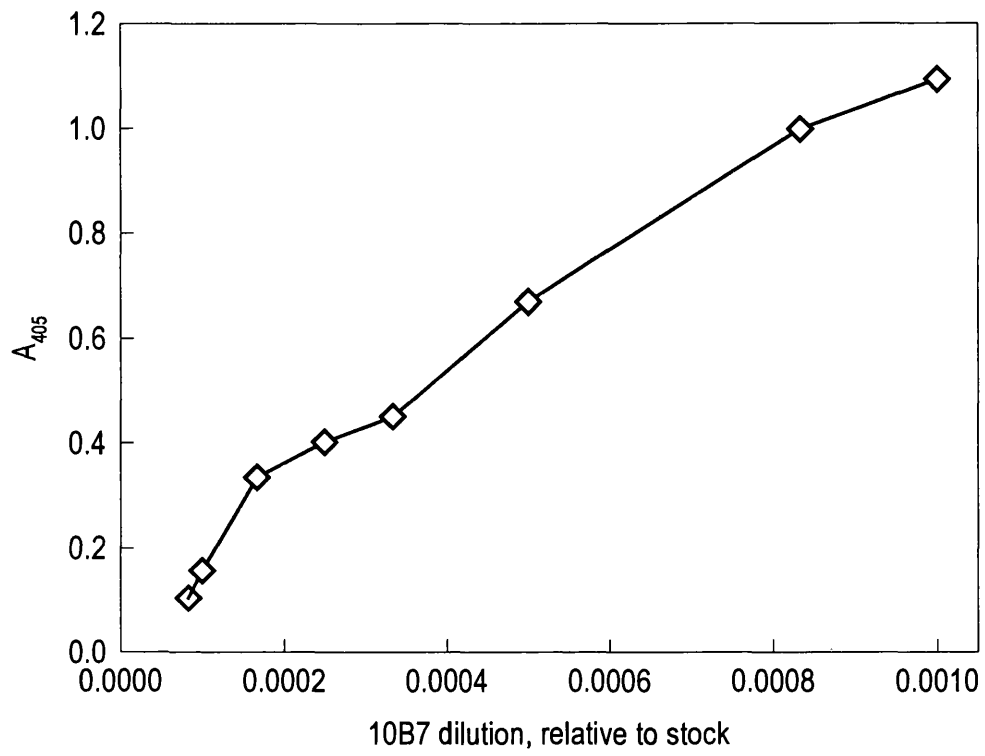

Figure 10. Test of tenfold range of 10B7 dilutions.

4.1.9 Stop Reagents

Azide was recommended by another manufacturer as a stop reagent for their ABTS substrate; a reference quoted by the manufacturer of the ABTS used suggested sodium dodecyl sulphate (SDS) at 1mM. SDS was tested at 1mM final concentration (W. Reynolds, personal communication). Repeated spectrophotometer readings of the same plate were taken over 20 minutes; they displayed slightly less divergence over time in the presence of SDS (Figure 11) (04.03.99).

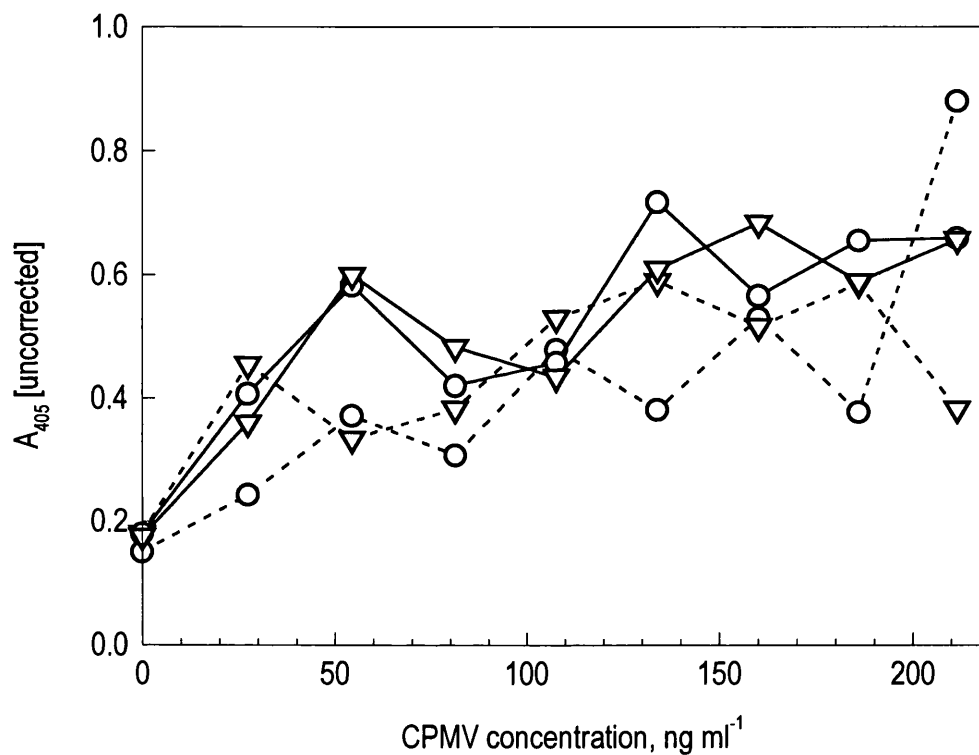

Figure 11. Effect of SDS stop reagent.

No stop reagent, - -; stop reagent SDS, —; old 10B7, ○; new 10B7, ▽.

4.1.10 Incubation Time

Incubations were each carried out for an hour, although it was believed that most binding takes place within 10 min (H. A. Young, personal communication). An experiment compared the 1 h standard incubation time with a 'fast' time of 20 min per step, using CPMV standard S1 (212 ng ml⁻¹) (Figure 12) (30.04.99). Comparable binding to that at 1 h was not achieved in 20 min, for at least one step in the multistage assay. Blank readings were unchanged.

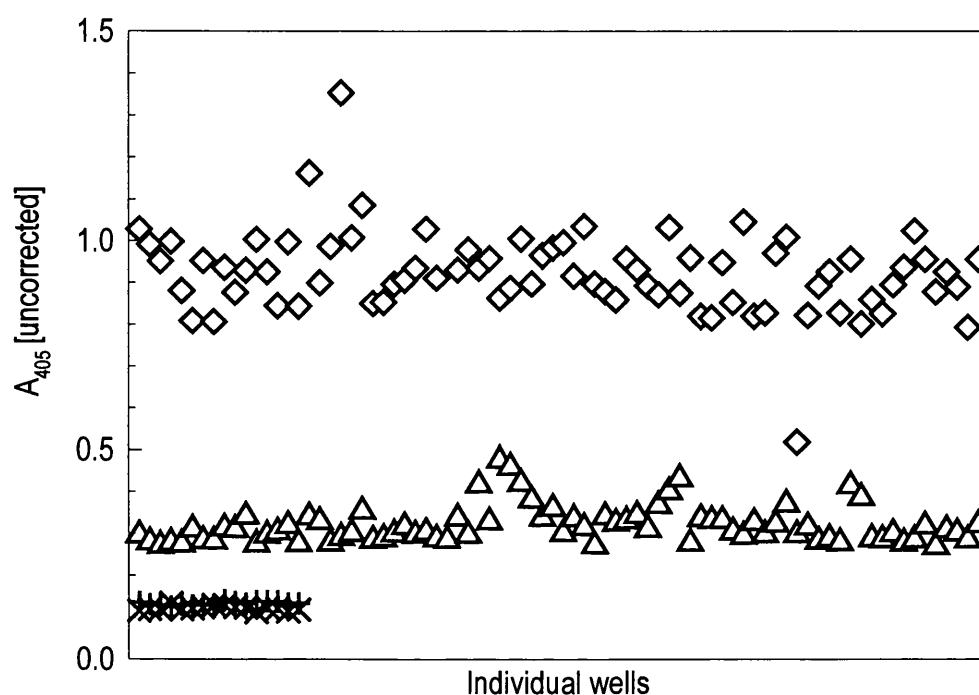

Figure 12. Comparison of fast and slow incubation times.

CPMV standard S1, 1 h steps, ◇ ; CPMV standard S1, 20 min steps, △ ; blank, 1 h steps, + ; blank, 20 min steps, × .

4.2 Protein Assay

4.2.1 Assay Description

The total protein assay was a microwell plate version using BioRad kit reagents ('DC' Protein Assay Kit II, BioRad, Hemel Hempstead, UK). Here, the plate acted only as a container, so the type was not crucial as long as it was low protein binding, and Sarstedt plates were used successfully. The dye-based assay was based on the method of Lowry *et al.* (1951) refined by Peterson (1979). Alkaline copper tartrate solution, 20 μl , was added to each well, followed by 40 μl of test sample or standard and finally 160 μl of Folin reagent. The first reagent donates copper metal which chelates in the protein, subsequently reducing the Folin reagent with the loss of 1, 2, or 3 oxygen atoms. Colour development is primarily due to the amino acids tyrosine and tryptophan, and to a lesser extent, cystine, cysteine and histidine. The reaction reaches near maximum colour development within 15 min and the colour changes are stable for 15-30 min after addition of reagents (BioRad instructions for use, 1997 version). The plate was incubated for 15 min at 37°C with 100 rpm orbital shaking, after which visible colour development (blue) was read electronically by a spectrophotometer at a single wavelength of 750 nm. Samples at 1/50 to 1/100 dilution in 10mM phosphate buffer were calibrated against an onboard standard curve of 20 to 200 $\mu\text{g ml}^{-1}$ bovine serum albumin (BSA) freshly prepared and controls previously made and stored as single use aliquots at -80°C.

The measured total protein content gave a broad indication of remaining contaminants of plant origin in the process fluid. It had been shown (Axis Genetics unpublished SOP, 1997; and data not shown) that no conversion was necessary from results obtained with a BSA standard curve to an equivalent concentration of CPMV. Hence, for incompletely purified samples, the unwanted protein residue could be estimated by subtracting the CPMV content measured by ELISA. Alternatively, for samples believed to be pure, the amount of CPMV could be estimated more easily than by ELISA.

The template comprised standards and controls in duplicate, blanks (of which six were averaged per plate), and samples in duplicate for each dilution.

4.2.2 Standards and Controls

The standards and controls routinely used in the protein assay are shown in Table 4.

Table 4. Standards and controls for protein assay.

Standard or control	S1	S2	S3	S4	S5	S6	H	M	L
Protein concentration, $\mu\text{g ml}^{-1}$	20	50	80	120	160	200	180	100	40

S1-S6, standards; H, M, L, high, medium and low controls.

4.2.3 Sources of Error

Errors may have arisen from sampling of inhomogeneous mixtures, improper mixing, use of a poorly adjusted pipette, incorrect calculation of dilutions, sample degradation during storage, cross-contamination between plate wells, or mistiming of assay stages.

4.2.4 Edge Effects

To test whether edge wells on the plate layout incubated differently (as implied by Axis' suggested layout excluding such wells) or all were equivalent, $100 \mu\text{g ml}^{-1}$ dilutions of BSA were added to all wells either individually or by multipipette. No significant differences were seen between a) edge or middle wells, b) successive readings over up to 25 min of a single well, or c) multipipetted or individually filled wells (Table 5) (18.03.98).

Table 5. Plate layout test comparing edge and middle wells.

Wells location	N	Multipipetted A_{750} , OD units		Individually filled A_{750} , OD units	
		μ	SD	μ	SD
edge wells	36	0.453	0.037	0.516	0.037
middle wells	60	0.457	0.015	0.504	0.034

A_{750} , absorbance measured at 750 nm wavelength; OD, optical density relative units; N, number of samples; μ , mean of sample readings; SD, standard deviation of sample readings.

4.2.5 Double Wavelength Reading

The manufacturer quoted a minimum response wavelength of 405 nm in addition to the 750 nm detection maximum. Plates were read twice and the dual wavelength comparison, $A_{750} - A_{405}$, calculated. The blank average (0.015) and curve fit ($r^2=0.999$) were acceptable, errors in the standards were low, and predictions of values for the controls were satisfactory, but there was a limited range of response to the standards. The highest, S6 ($200 \mu\text{g ml}^{-1}$), gave readings of only 0.188 and 0.177 ($A_{750}-A_{405}$, OD units) (24.07.98). It was decided to use the single-wavelength reading, in order to take advantage of the full detection range of the spectrophotometer, while leaving other assay conditions unchanged, and rely on buffer blanks for a baseline.

4.2.6 Interference by Chlorophylls

To test whether any extracted plant pigments, such as chlorophylls, interfered with the assay response, an equal volume of buffer was used instead of reagent B with leftover samples. All read as zero $\mu\text{g ml}^{-1}$ or less, net of buffer blanks. This confirmed that such interference was not a problem (24.07.98). The maximum absorbances of the chlorophylls A and B in solution are between wavelengths of approximately 400-500 and 600-680 nm respectively (Bonner and Varner, 1976); the protein assay is read at 750 nm, at which there was little residual absorption by the chlorophyll absorbance peaks in homogenate solution (data not shown).

4.2.7 Interference by Ammonium Sulphate

A test of compatibility with the ammonium sulphate precipitant was carried out using standards S1-S6, and standards with added ammonium sulphate, to 0.1M (SA1-SA6) and 0.2M (SB1-SB6) final concentrations. Standards with 0.5M ammonium sulphate had previously not been readable. Standards SA, at 0.105M ammonium sulphate, turned blue (indicating protein content) as normal on the day of assay. Standards SB, at 0.204M ammonium sulphate, did not turn blue until the next day (21.01.99). Samples, by comparison, were diluted from experimental concentrations of up to 3.4M ammonium sulphate by between $7/1000$ and $9/1000$, giving approximate test molarities of 0.024M-0.309M (before addition of reagents). The most concentrated samples of these would not be expected to give useful readings, but in fact data from these samples could not be used in any case due to volume uncertainties.

4.2.8 Sample Delay

There was no significant difference in total protein measured in samples of unclarified homogenate stored in the Coldroom at approximately 4°C for between 5 min and 25 h before loading the dilutions onto the plate (Figure 4) (11.05.99).

4.3 Conclusions

The ELISA method as documented in the Methods (section 3.4.3 on page 31) and detailed in the SOP (section 11.3.1 beginning on page 137) was developed and confirmed as described above. Although faster, cheaper, more readily available alternatives were tested, the recommended incubation times, plates and antibodies were more satisfactory. Dilutions of the detection antibody remained variable by batch, so were retested as necessary, and recalibration following changeovers in CPMV stocks was documented and confirmed by ELISA and spectrophotometric assays. The protein assay (see also Materials & Methods section 3.4.4 page 32 and SOP section 11.3.2 page 140) was more straightforward, and apart from an improvement to the plate layout, modifications to its SOP were minor. Neither undesirable cross-reactions nor degradation presented problems in the protein assay.

5. Initial Extraction

“For obscure reasons people seem to be much less concerned about the internal appearance of small pieces of food than they are about large ones. This can readily be confirmed at cocktail parties or in an Indian restaurant.” (Pirie, 1971b)

“Cryonicists believe that people can be frozen immediately after death and reanimated later when the cure for what ailed them is found. To see the flaw in this system, thaw out a can of frozen strawberries. During freezing, the water within each cell expands, crystallizes, and ruptures the cell membranes. When defrosted, all the intracellular goo oozes out, turning your strawberries into runny mush. This is your brain on cryonics.” (Shermer, 2001)

5.1 Introduction

5.1.1 Strategies for Extraction of Virus from Leaves

A new generation of human and animal vaccines is under development based on cowpea mosaic virus (CPMV) (Usha, 1993; Porta and Spall *et al.*, 1994; Dalsgaard *et al.*, 1997). The viral capsid is employed as a physical support for multiple antigen presentation. Native or modified CPMV efficiently replicates in the cowpea (black-eyed bean) host plant, in a mosaic infection of the leaves.

Viruses localise in the cytoplasm of infected leaf mesophyll cells one thousand times their own diameter (Figure 13). They accumulate scattered singly, clustered in crystalline inclusions, and embedded in reticulate vesicles called viroplasms (de Zoeten *et al.*, 1974). Therefore, both the plant cell wall and its membrane must be breached in order to release the viral product.

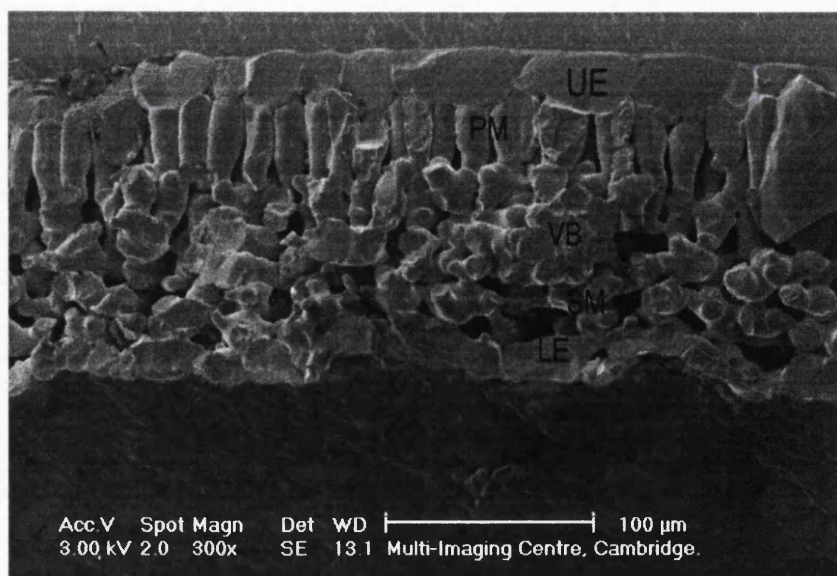

Figure 13. Scanning electron micrograph of a freeze-fractured cowpea leaf.

Cell types: UE, upper epidermis; PM, palisade mesophyll; SM, spongy mesophyll; VB, vascular bundle; LE, lower epidermis.

Young leaf material from cowpeas contains the highest concentration of virus of the plant parts, and the soft, thin lamina is relatively easily disrupted. The fibrous parts, petiole and midrib, are more inconvenient to process and it has been suggested that they be stripped out before small scale processing (Walkey, 1991). Leaves can be processed fresh, or stored frozen at -80°C until required.

Broken plant cells release diverse constituents which influence processing. Those affecting physical properties include stiff cell wall fibres, compressible particulate whole organelles, and viscous pectins and nucleic acids. Chemically active species include reactive phenolics, separate phase lipids, degradative enzymes and labile proteins. Disrupting internal organelles is unnecessary and counterproductive because of product contamination, but difficult to avoid. Adding buffer to reduce the viscosity of the homogenate (and deliberately releasing the dilute cell contents) means that the major bulk contaminant present is water.

Lugg (1939) achieved 92-95% recovery of leaf nitrogen (a measure of total protein) from spinach by fine grinding in a large volume of borate buffer, pH 9.2, with centrifugation to remove debris. Crook (1946) attained 90-95% protein release from tobacco leaves by twice mincing in distilled water, washing, grinding, and alkaline extracting at pH 8.0. The average protein content of the tobacco was estimated at 15% of the dry matter. These yields imply that co-localised virus should be accessible to a similar degree.

Wild type CPMV yields of up to 2 mg g⁻¹ of infected fresh weight plant tissue have been reported (van Kammen and de Jager, 1978). For a chimeric construct, 1 mg g⁻¹ has been achieved, i.e. 50-60 mg from 5 plants (Dalsgaard *et al.*, 1997), and recently, 1.2 mg g⁻¹ (Brennan *et al.*, 1999). In the standard method of Klootwijk *et al.* (1977), fresh leaves are disrupted in two millilitres of 0.1M phosphate buffer per gram of leaf in a Waring Blender to furnish an initial extract.

More radical approaches have been suggested which may be applicable to recovering cell sap containing competent viruses. Non-thermal processing techniques include the application of very high hydrostatic pressure (100-900 MPa), which inactivates micro-organisms and enzymes, coagulates proteins and permeabilises cell membranes. However, it is usually used in conjunction with heating to 60-90°C to achieve effective food sterilisation (G.V. Barbosa-Cánovas, personal communication; Grant *et al.*, 2000). In pulsed electric field food processing, 10-100µs pulses of 5-100 kW cm⁻¹ field strength are cycled 10-20 s⁻¹ at 20-40°C. This causes pore formation in cell membranes leading to leakage, and can inactivate enzymes (Vega-Mercado *et al.*, 1997). Juice

yield from fruit and vegetables can be enhanced 10-30% by pulses of specific energy input 15 kJ (kg food)⁻¹ for several seconds (Knorr, 1998).

5.1.2 Freeze-thaw

Significant fractions of many leaf proteins can be coagulated by freezing (Pirie, 1971a). Lately, interest has been reported in freeze-thaw cycles alone as a relatively 'clean' extraction technique. Minocha (Minocha *et al.*, 1994; Minocha and Shortle, 1993) compares mechanical homogenisation directly with a triple freeze-thaw cycle. The freeze-thaw method is consistent, precise, and gives a comparable result to homogenisation, for extracting inorganic cations and polyamines from woody and soft tissues into 0.01M HCl. The method allows contained processing of samples. Scale up concerns would include lag times for heat transfer and the inherently batch nature of the operation; on the other hand large fragments of leaf would be easy to remove by filtration or screening.

Polson (1993) and Polson and van der Merwe (1993) imposed an electric potential gradient across sliced fresh or thawed frozen whole plants or leaves, in an aqueous buffer of extremely low conductivity (<0.01M) to minimise heating. Plant viruses with strongly negative surface charge were electro-extracted and collected against a cellophane membrane, which allowed migrating small molecules to pass through. Almost no large or small solids contaminated the derived preparation and yield was estimated to be comparable to conventional disruption. The scale up of this technique has not been reported.

Irreversible freezing damage to plant cells results from large ice crystals extending from extracellular nucleation sites (where they are nonlethal) into the live protoplast, puncturing membranes and disturbing the physiological ion balance. Numerous, tiny crystals or amorphous glassy ice formed on instantaneous freezing cause no direct physical damage, but re-warming can allow sublimation to vapour or growth to a damaging size, which occurs below -10°C (Echlin, 1992). Experimental material was frozen in bulk at the -80°C storage temperature, with a prolonged cooling time (it takes more than 1 h to freeze 1 kg of leaves). Some cellular damage is a necessary prerequisite for virus extraction, but it is not known whether this freezing damages virus. Moreover, it is practically difficult to separate any effect of freezing on virus stability inside the cell from the efficiency of its subsequent extraction.

5.1.3 Mechanical Disruption

Three general methods are used for disrupting microorganisms: bead milling, high-pressure homogenisation, and microfluidisation (jet impaction) (Keshavarz-Moore, 1996). Of these, the

largest debris but also the highest final viscosity of disrupted microorganisms was given by the bead mill; the others are unsuitable for unclarified homogenised leaf slurry due to the risk of blockage of the orifice. Bead mills are used for disrupting yeast, Gram positive and Gram negative bacteria, filamentous fungi and algae. However, fines of colloidal ground glass result from extreme processing conditions. The kinetics of cell rupture in mills are well characterised (Limon-Lason *et al.*, 1979). Tumbling whole leaves gently with large glass and resin beads to selectively break epidermal gland trichomes (leaf hair cells) yields similar quantities of target enzymes as isolation from whole leaf homogenates (Gershenzon *et al.*, 1987). According to Gershenzon, for optimal recovery it was necessary to use a methylether sulphone (MES) buffer with added sugar, salt, three reducing agents and two adsorbents. Contaminating soluble proteins were present at only 0.005-0.02% of leaf fresh weight, compared to 0.2-0.9% in homogenates. This is the equivalent of a purification factor of 10 to 40 times - although the added chemicals were also present.

5.1.4 Blending and Homogenisation

The jug-type blender traditionally used by plant virologists (e.g. Waring) operates in batch mode, with a maximum capacity of 5 L. It is not a large scale operation (although Axis apparently intended to use 13 serial blenders in their clinical trials production process). Therefore, a high shear mixer-emulsifier (Silverson Machines Ltd, Chesham, UK) was instead used to homogenise leaf tissue and disperse it into buffer solution. The high speed rotor-stator assembly disintegrates and maintains a suspension by a combination of successive suction, milling, high-shear and mixing actions. Versions of the machine are available as batch mixers or continuous in-line pumps up to the largest industrial sizes ($55 \text{ m}^3 \text{ s}^{-1}$), allowing scale up based on the same disruption principle. In practice, the manufacturer recommends that machines are empirically scaled up based on processing volume, although they are designed with constant tip speeds (7 m s^{-1}) across the range (H. Rothman, personal communication). There is little information on machine design or performance in the literature, although the kinetics of micromixing with a small, variable-speed rotor-stator device have been evaluated for chemical reaction promotion (Bourne and Garcia-Rosas, 1986). A locally intense shear field within a batch mixer is created without undue power requirement. Similar high-shear homogenisers of this type are made by, among others, Kinematica (Polytron series, Kinematica, Lucerne, CH, distributed by Philip Harris Scientific, Ashby de la Zouch, UK), Perstorp Analytical UK Ltd (Maidenhead, UK), and Joshua Greaves & Sons Ltd (Ramsbottom, UK).

Homogenisation of finely crushed frozen leaves in a minimal volume of buffer was originally used in this study to produce a readily pumpable feedstock for a bead mill, the inlet of which would otherwise block.

5.1.5 Bead Milling

Bead milling is used for disruption of bacterial cells and pulverisation of tough powders such as pigments.

5.1.6 Aims

For therapeutic use, virus particles must be separated from host plant constituents including coarse fibres, pigments, degradative enzymes, immunogenic proteins and carbohydrates. There are as yet no published reports of large-scale processing and purification of virus particles from leaves for therapeutic use, and little quantitative data on initial extraction. The following work quantifies the extraction efficiencies achieved by simple, scalable techniques of disruption, using both fresh and frozen starting material, investigates batch to batch variations and differences in yield between apparently identically grown plants, and the consequences of extended storage.

5.2 Results and Discussion

Initial disruption methods of freezing and subsequent thawing (freeze-thaw), high-shear homogenisation and bead milling were investigated. Freezing assists mechanical crushing, enables decoupling of processing from production, and may help to damage host cells, enhancing the release of cytoplasmic virus. Freeze-thaw is an inevitable part of process extraction from stored frozen leaves, which are crushed before use to assist mixing in the disruption equipment.

5.2.1 Freeze-thaw

The amounts of CPMV and protein released into various buffers prior to processing were measured. Frozen leaves (batch 8), crushed as described, yielded 0.6 ± 0.2 mg g⁻¹ of CPMV and 5.7 ± 0.6 mg g⁻¹ of protein in Tris-HCl, sodium citrate or RO water after 1 h at ambient temperature. After an additional 24 h at 4°C, no further change was detectable. There were no significant differences attributable to buffers. Within 1 h, frozen leaves (batch 1) released 0.3-1.0 mg g⁻¹ of CPMV, and 3-10 mg g⁻¹ of protein into Tris buffer. Fresh leaves (batch 4, day old) were sliced into similarly sized pieces as those of frozen crushed material. When soaked in Tris buffer for 1 h or overnight, 0.14 ± 0.03 mg g⁻¹ of CPMV was detected. Likewise, fresh leaves (batch 6) contained 0.14 mg g⁻¹ of CPMV and 1.0 mg g⁻¹ of protein immediately before processing. The

higher yields obtained after freezing and crushing compared to slicing alone indicate that freezing enhances virus release. A theoretical calculation of expected yield from cut cells (see below) gave approximately 0.1 mg g⁻¹, which was confirmed by experiment. The crushing step could be mechanised by using a batch processing machine such as the Stomacher (Stomacher, Seward, London, distributed by Philip Harris Scientific, Ashby de la Zouch, UK). A calculation was made of the potential release of cut cells' contents:

- leaf pieces are 2 mm × 3mm
- cells are 30 μm × 50 μm i.e. 0.030 mm × 0.050 mm
- treat leaf lamina as two-dimensional as only cutting vertically
 - ∴ 2 / 0.050 = 40 a side and 3 / 0.030 = 100 another side
 - ∴ 40 × 100 = 4000 cells per piece
- edges are cut half-cells
 - ∴ (100 + 39 + 99 + 38) × ½ = 188 cut cells
- assume cut cells' contents fully released
 - ∴ direct release = 188 / 4000 × 100% = 3.5%
- this gives 0.14 mg g⁻¹ on a basis of 4 mg g⁻¹ maximum releasable virus

The enhanced yields after freezing imply that there is an additional effect of freeze-thaw. The mechanism may be indirect ice rupture of membranes not directly cut.

5.2.2 Blending

Protein yields after disruption by various methods were as shown in Table 6.

Table 6. Protein yields after disruption by various methods.

Disruption equipment	Protein concentration after disruption, mg ml ⁻¹
blender	3-8
pilot batch Silverson	5-7
lab batch Silverson	4-6
milled	1-2 ^a

^a *diluted 2×*

5.2.3 Milling

The reported attrition of glass beads was limited to a 0.5% loss.

Over several experiments the amount of virus potentially released by bead milling was calculated to be between 5-70% more than by homogenisation alone, based on its relative concentration at the two steps*. Using frozen leaves (batch 7), a 65 ml batch feed of

* Averaged results from each of 8 process runs in order of experimentation: CPMV only, individual run percentages, basis 100% for homogenised B; milled drained M1, M1+wash M2; separately for each run, both fresh and frozen leaves:

- potential extra +28% over homogenised (26%, 41%, 25% frozen; 15%, 6% fresh; 7%, 34%, 69% frozen)
- but the actual M1 gave only 42% recovery (54%, 59%, 51%, 43%, 32%, 37%, 44%, 65%)
- finally recovered in M2, 76% of B amount (91%, 69%, 65%, 54%, 52%, 83%, 88%, 102%)

homogenate produced 22 ml of milled mulch recovered undiluted by freely draining the beads. Washing with an excess of buffer until the rinse ran clear, a total of 773 ml of diluted milled mulch was obtained. Milling followed by this 12-fold dilution yielded 3.2 mg g⁻¹ of CPMV, only a 5% increase from after homogenisation (exclusive of a 2% sampling loss). The total expected maximum releasable virus, calculated from the maximum concentration of virus output times the maximum volume of process fluid input, was 3.6 mg g⁻¹, a 20% potential improvement over homogenisation alone. However, this amount was not recoverable, even after washing. (Losses in the equipment are disproportionately high for these small batches; continuous operation would improve the percentage recovery.) There was no difference in the total amount of protein released by milling, 24 ± 12 mg g⁻¹, to that from homogenisation alone, 24 ± 8 mg g⁻¹. This implies that cells were not further disrupted by additional milling. At large scale, even a 20% increase in release may not be cost effective, when set against the inconvenience of an additional unit operation: encompassing capital and running costs, space requirement, process fluid volume loss in holdup, additional processing time, cleaning, validation, downtime, and variations in performance.

5.2.4 Batch Homogenisation

Fresh leaves (batch 8) pre-sliced into 1-2 mm × 10 mm pieces were homogenised for 60-480 s. Neither virus yield, $4.0 \pm 0.5 \text{ mg g}^{-1}$, nor protein extraction, $31 \pm 5 \text{ mg g}^{-1}$, varied with homogenisation time. The fluid behaved as a thick paste at first until cells were disrupted and the cytoplasmic contents released; by 1 min the stirred consistency was more like thin soup (see 5.2.7 on page 71 for more detailed Rheology). Because of this decrease in viscosity, the maximum processing speed of the homogeniser varied with the time for which it had been processing homogenate (Figure 14).

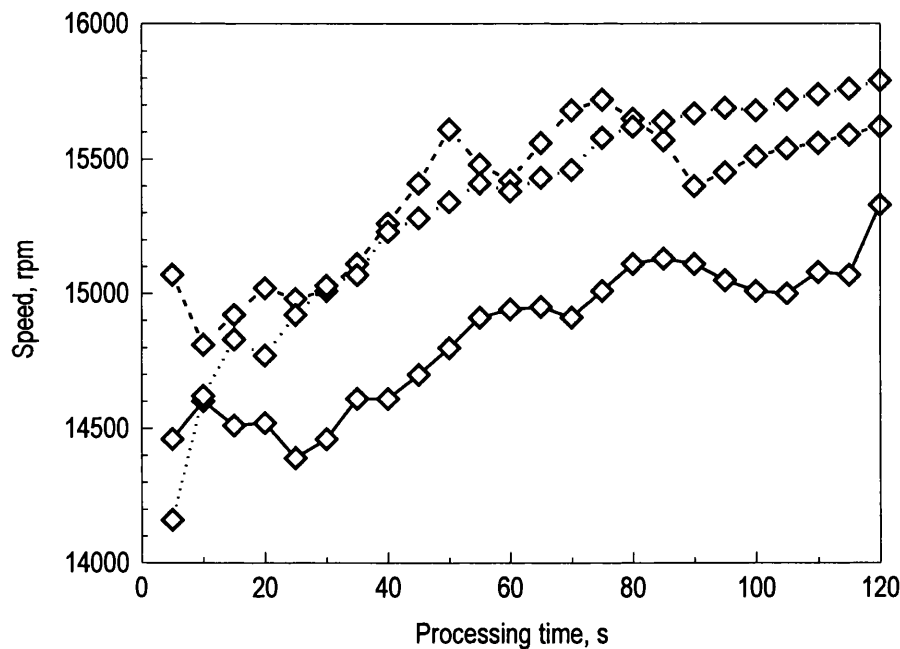

Figure 14. Batch homogeniser speed during processing.

Data from three runs shown separately.

Fresh leaves (batch 10) from three plants were separately homogenised, yielding 5.3 ± 0.6 mg g^{-1} of CPMV with no significant difference between individual plants (Figure 15). An average yield of 38 ± 3 mg g^{-1} of protein equally applied to these and an uninfected control. The low level of CPMV observed in the uninfected material may be attributed to cross-infection in the glasshouse. Individual leaves of the same plant have different ages and hence infection ages, therefore the virus load would be likely to vary between leaves in a plant. Individual leaves from one plant were not tested. Yields from three individual plants of a batch, each comprising fresh leaves of different ages, but similar one plant to the next, did not differ. Separate use of leaf cohorts, e.g. the youngest leaves only at any one time, would require refinements to the method of harvesting, such as successive mowing. Currently plants are raised in controlled contained environment conditions indoors, and leaves individually hand picked.

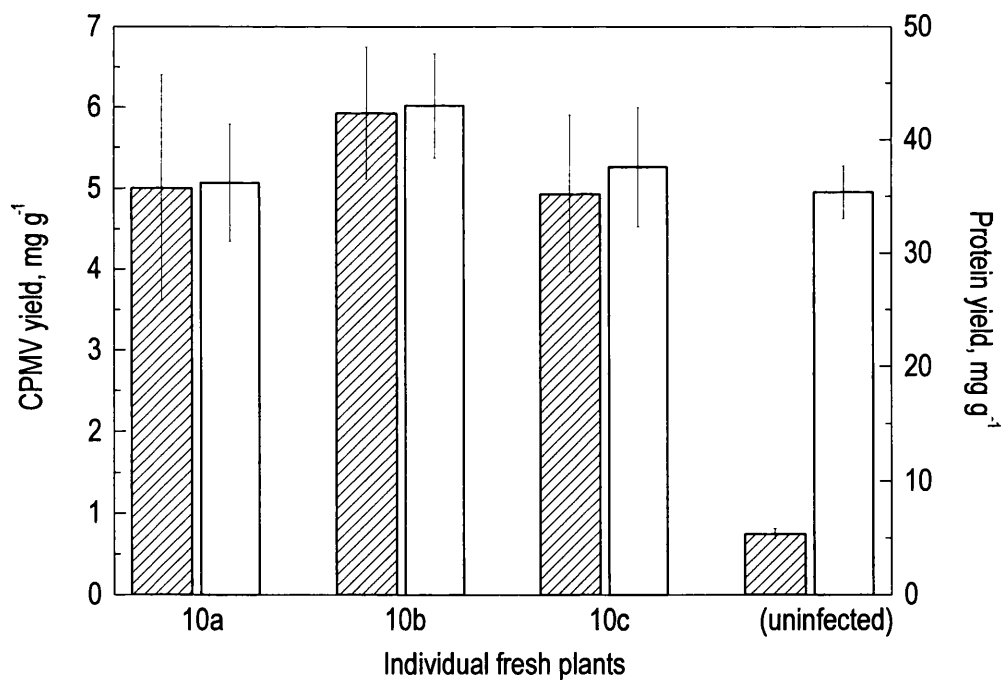

Figure 15. Yields from fresh leaves of four individual plants.

CPMV, ▨; protein, □; 10a, 10b, 10c, individual plants of batch 10.

Frozen leaves (batch 8) were homogenised for 5-480 s (Figure 16). Up to $3.4 \pm 0.5 \text{ mg g}^{-1}$ of CPMV was extracted after 15-120 s processing. However, only $2.8 \pm 0.8 \text{ mg g}^{-1}$ was recoverable at 240 s and 480 s (480 s not shown). For protein, release of $34 \pm 2 \text{ mg g}^{-1}$ peaked around 120 s. This agreed with results previously obtained (batch 1) of $2.9 \pm 0.5 \text{ mg g}^{-1}$ of CPMV and $33 \pm 5 \text{ mg g}^{-1}$ of protein averaged over 60-480 s.

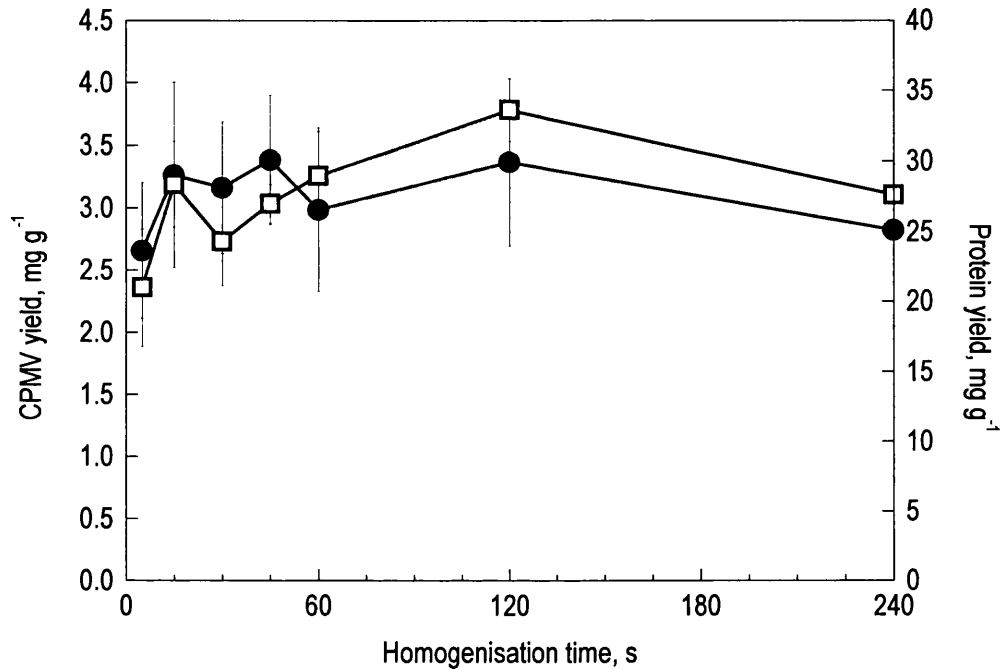

Figure 16. Release from frozen leaves homogenised for 0-240 s.

CPMV, ●; protein, □.

Frozen leaves did not yield significantly less virus or total protein than fresh leaves from the same batch when homogenised for 60 s (Figure 17). In each case the 10-20% disparity is within the detection error.

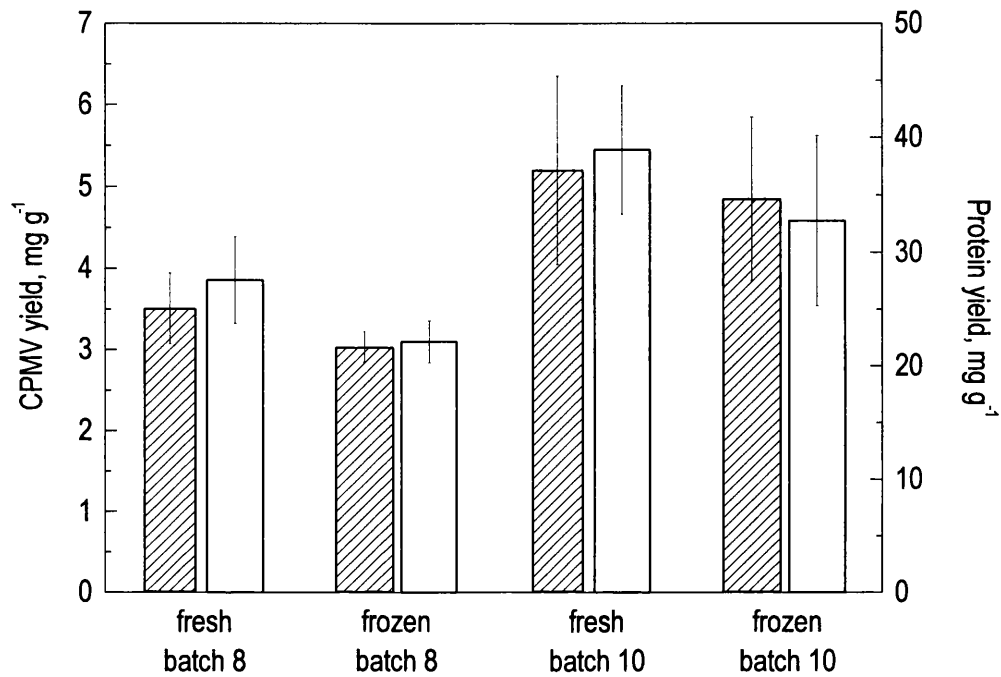

Figure 17. Comparison of yields from fresh and frozen leaves of different batches.

CPMV, \square ; protein, \square .

Yields from the different preparations (fresh, frozen) and types of disruption (crushed, sliced, blended, milled) using various buffers (RO, Tris-HCl, sodium citrate) were summarised (Table 7).

Table 7. Comparison of CPMV yield and soluble protein contamination after disruption.

Processing	Batch	CPMV mg (g leaf) ⁻¹	Protein mg (g leaf) ⁻¹	Comments
FT	8	0.6	5.7	NS 1 h or 24 h, NS Tris-HCl, sodium citrate or water
FT	1	0.4 →0.7	ND	0→1 h, Tris-HCl
FT	3	ND→1.1→0.9	3.8→5.7→ND	0→1→24 h, RO
FT	UN	ND	7.8	24h, RO
sliced fresh	4	0.14	ND	NS 1 h or 24 h, Tris-HCl
H, FT	1	3.8	37	
H, FT	2	4.0	38	
H, FT	3	4.8	42	
H, FT	4	3.3	25	
H, FT	5	3.4	24	
H, FT	6	2.3	18	leaves had been defrosted in transit
H, FT	7	4.2	24	
H, FT	8	2.2	16	
H, FT	9	3.0	19	
H, FT	10	3.6	24	
H	none	0.02	0.7	buffer only
H, sliced fresh	8	3.0	22	NS 1, 2, 4 or 8 min
H, sliced fresh	10	3.8	29	
H, FT	8	2.5→2.0	25	CPMV NS 15 s, 30 s, 1 min or 2 min→NS 4, 8 min protein maximum at 2 min
H, FT	1	2.0	24	
milled, H, FT	1			
milled, H, FT	7	3.2	24	NS to homogenised

Key: FT, frozen-thawed; H, homogenised; UN, cowpea leaves not infected with CPMV; ND, not determined; RO, reverse osmosis-purified water; NS, not significantly different results between conditions stated.

5.2.5 Batch and Storage Variability

Frozen leaf material from each of ten separately grown batches was homogenised for 60 s, with considerable variation in yields of both the CPMV and protein (Figure 18). This variation may be caused partly as a result of differences between batch to batch cultivation and harvesting conditions, and partly because of differences in storage time of (all batches of) the frozen material. To assess the impact of storage time on release, additional experiments were carried out in which several batches were frozen for different lengths of time. For six batches, previous homogenisation data were available: virus yield had increased in the intervening five months of freezer storage by 1-3 mg g⁻¹ in every case. Subsequent homogenisation data, 7 months later, showed a further increase in yields for CPMV in 8 out of 10 batches, but again no consistent change in protein for each batch. Maximum yields ranged across batches between 3.4 ± 0.4 (batch 6) and 10.4 ± 1.9 (batch 3) mg g⁻¹ of CPMV, and between 24 ± 2 and 57 ± 11 mg g⁻¹ of protein.

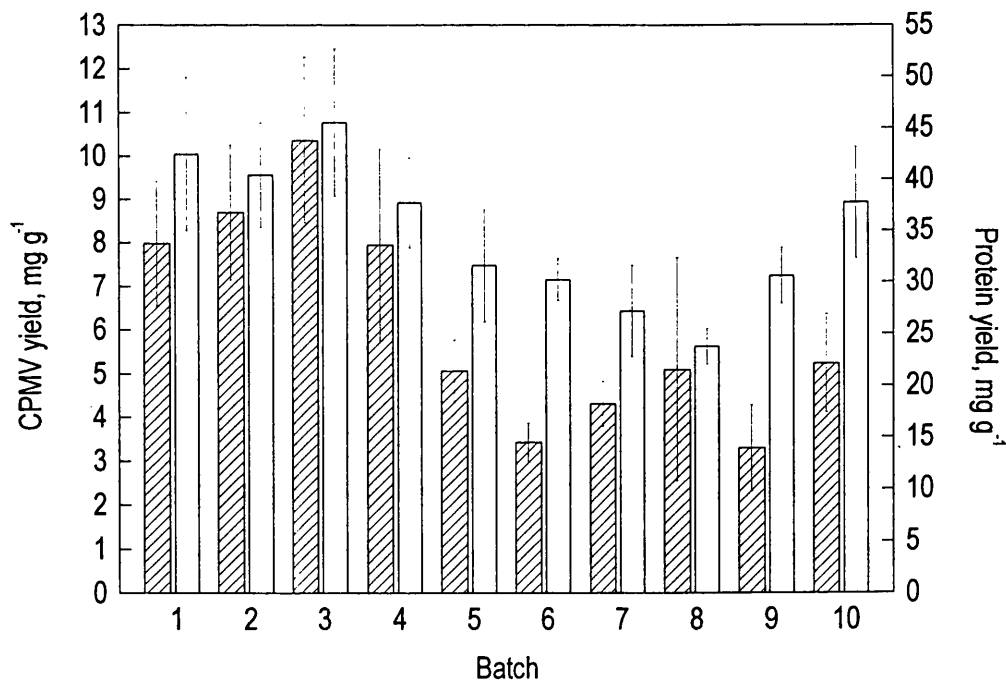

Figure 18. Batch to batch variation in yields.

CPMV, ▨; protein, □.

Infected plants have been reported to contain a maximum of 4 mg g⁻¹ of virus (TMV) (Matthews, 1991); 0.1-2 mg g⁻¹ for comoviruses (Lomonosoff and Shanks, 1999). Typical final yields quoted after purification are 1-2 mg g⁻¹ (Dalsgaard *et al.*, 1997). The true potential yield (total virus content in the plant) is not known. Experiments here indicated yields of up to 3.4-10.4 mg g⁻¹ of CPMV and 24-57 mg g⁻¹ of protein, dependent on batch, after long-term deep-frozen storage and disruption by homogenisation.

After homogenisation, between 5-20% of the total extracted soluble protein could be accounted for by CPMV. It has not been possible to relate variations in yield and relative extraction purity to any particular growth or harvesting conditions, although batch to batch variations are pronounced. Indoor cultivation is based on common seed stocks of cowpea and infective material with standardised inoculation, growth period, temperature and lighting. Individual leaves of the same plant (not tested here) have different infection ages and hence infection ages, so virus load would be likely to vary between them. Separate use of such leaf cohorts would require modifications to the method of harvesting, such as successive mowing. Plants were raised in controlled contained environment conditions indoors (in accordance with the UK requirements of MAFF and HSE for genetically modified plant pathogens), and leaves individually hand picked. If grown in the open field, more than one method of mechanised harvesting might be appropriate.

Since the virus is cytoplasmic whereas soluble proteins occur in many subcellular compartments, there should be a point beyond which further release of protein is unaccompanied by an increase in virus product. This cutoff was not evident: both CPMV and protein release increased to a maximum within 1-2 min and then plateaued without net further change.

For a single batch, yields typically increased with time in the freezer (Figure 19).

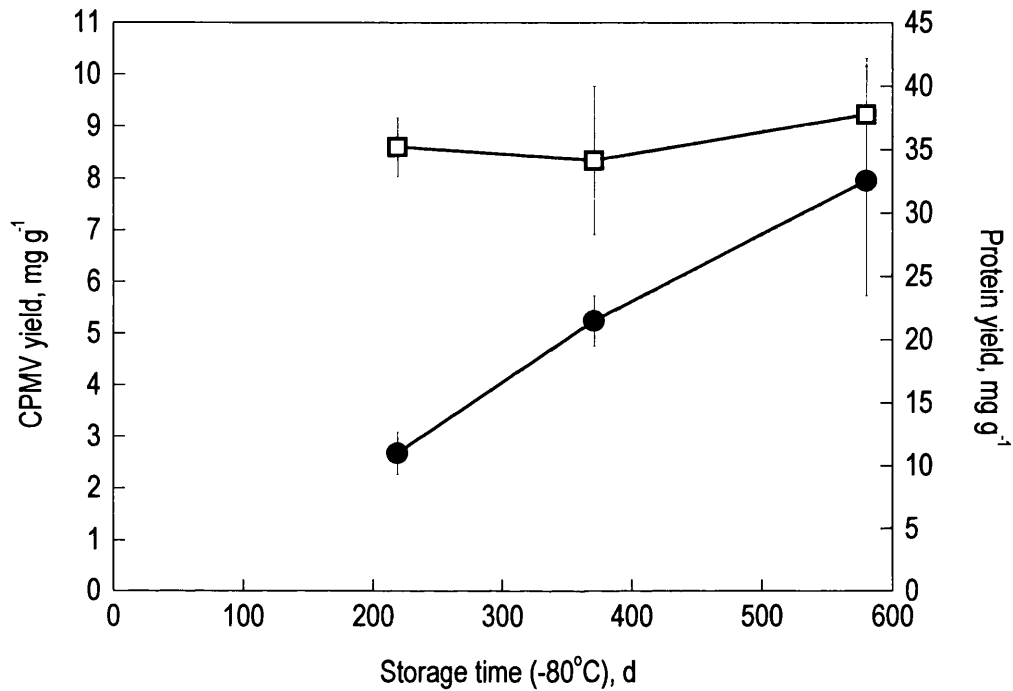

Figure 19. Effect of extended deep-frozen storage on homogenisation yields for a typical batch.

CPMV, ●; protein, □.

For all batches, yields after homogenisation for 60 s were plotted against time of previous storage at -80°C (Figure 20). Longer deep-frozen storage times, grouped in age classes of 100 d, correlated with increased yield of virus in every case, although with considerable scatter (inset). Yields were variable both within and between batches. Batch to batch variation in both protein and virus yield is likely to affect maximum recoverable virus even for a process of constant efficiency. Approximated linear fits implied 3 mg g^{-1} of CPMV to be achievable immediately and a further 2 mg g^{-1} for each year stored, on average. Similar predictions for protein were 26 mg g^{-1} initially with a further 6 mg g^{-1} per year stored. The effect in the case of protein is due to the earlier batches yielding more protein at any one time. It may be that intracellular aggregates of virus particles are weakened by temperature cycling, and therefore yields of virus increase. Since protein lacks these structures, protein yields do not. If the virus is indeed complexed, a rapid method of dissociation without denaturation would be more useful than long term storage. Alternatively, some undocumented difference during production of the raw material may be responsible for the change between earlier and later batches.

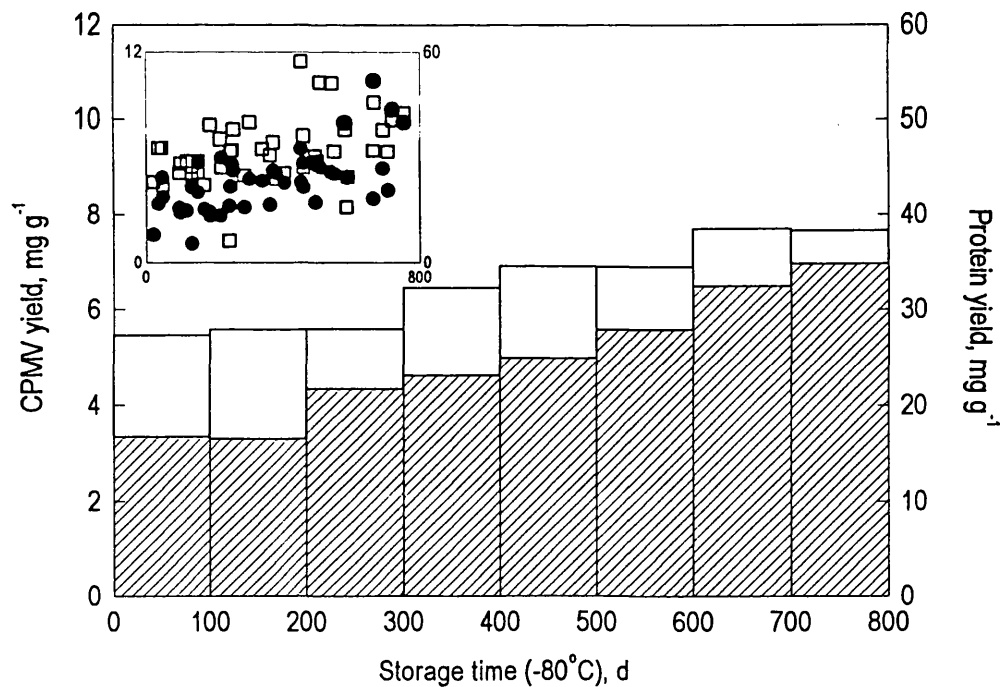

Figure 14. Correlation of yields with previous storage at -80°C across all batches.

CPMV, \boxtimes ; protein, \square . Inset shows scatter of underlying data: CPMV, \bullet ; protein, \square .

5.2.6 Continuous Homogenisation

Residence time in the continuous Silverson at the speed of 3500 rpm used for processing was <0.1 s per pass (J. Martin, personal communication).

Temperature rises of about 10°C in each case were noted: for continuous, to room temperature; for batch, from room temperature (Figure 21). Rates of rise were approximately 1°C per 10 s batch or per 1 pass continuous (attributing initial warming to heat transfer from ambient air). This is likely to have an insignificant effect on virus stability. A slight accelerating effect on denaturing enzymes is possible. Batch homogenisation gave a greater power input per unit volume of process fluid, because batch processing was carried out at maximum speed, whereas the continuous process was operated at minimum speed because of scale-down constraints. Also the batch processing container used had a smaller working volume than the full continuous flow chamber. Both factors would give rise to more heating of the process fluid during batch processing as used here.

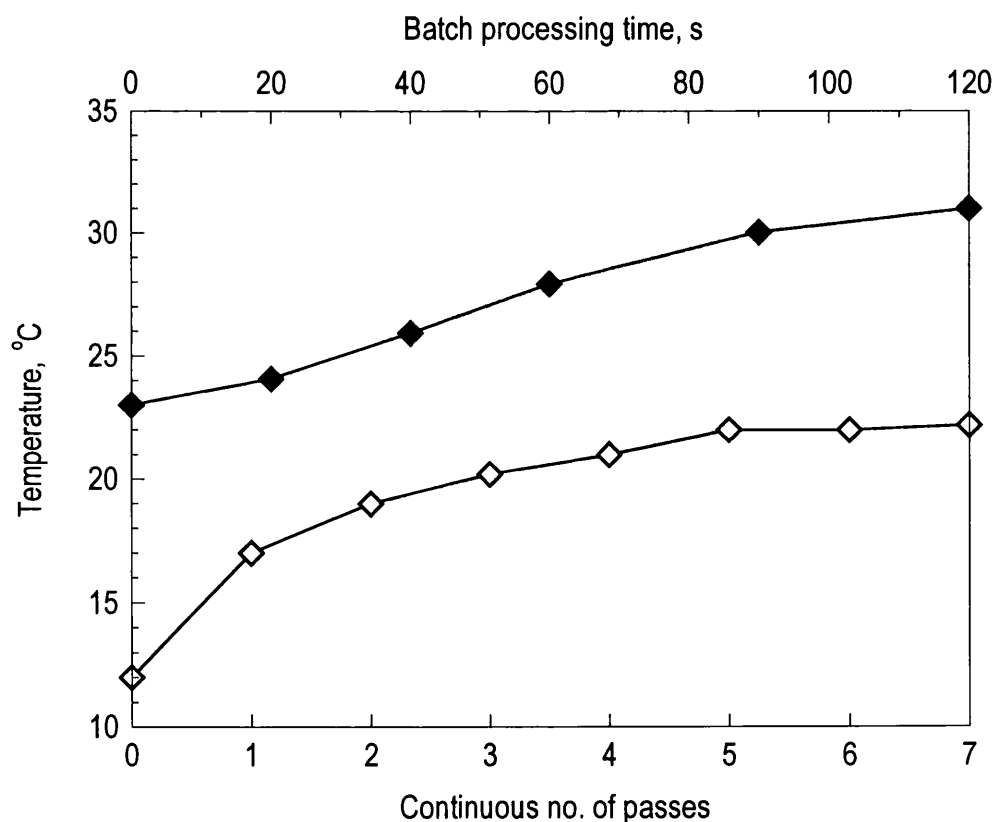

Figure 21. Temperature effects during batch and continuous homogenisation.

Batch, ◆; continuous, ◇. Note: the equivalent of 7 passes through the blades in batch processing took hundredths of a second, but in the continuous experiment, the set up time between passes lasted several minutes.

There was no effect of dilution on CPMV yield when undiluted batch homogenate (2 g leaf plus 5 ml buffer) was compared to 4× and 8× diluted leaf in buffer at the 60 s time point. Protein release was lower, approximately half for the 1/10 or 1/20 dilutions, compared to undiluted, at 60 s. There was no difference between protein release in continuous homogenisation, comparing 1/10 to 1/20 dilutions. In continuous homogenisation, there was no difference between wild type CPMV-infected leaf material and uninfected cowpea leaf protein yield, nor in the yields between 1-7 passes.

More protein, as much as 4×, was released per g of leaf from batch (at 1/1 dilution) rather than continuous (at 1/10) processing (Figure 22). In either mode, the maximum yield has already been achieved by the first time point: 20 s for batch, 1 pass for continuous.

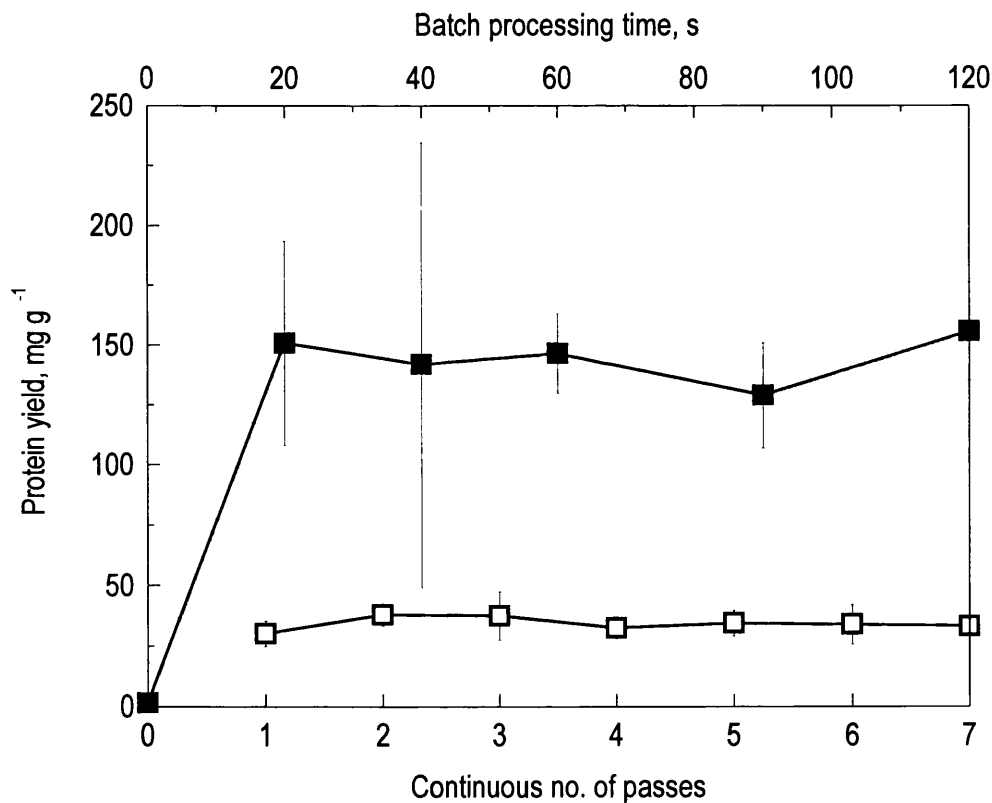

Figure 22. Protein release from batch and continuous homogenisation.

Batch, ■ ; continuous, □ .

More than twice as much CPMV was released by batch homogenisation (at 1/1 dilution, up to 120s) compared to continuous (at 1/10 dilution, up to 7 passes) (Figure 23). The error bars shown are ± 1 standard deviation of sample/assay variation only, therefore represent only minimum errors.

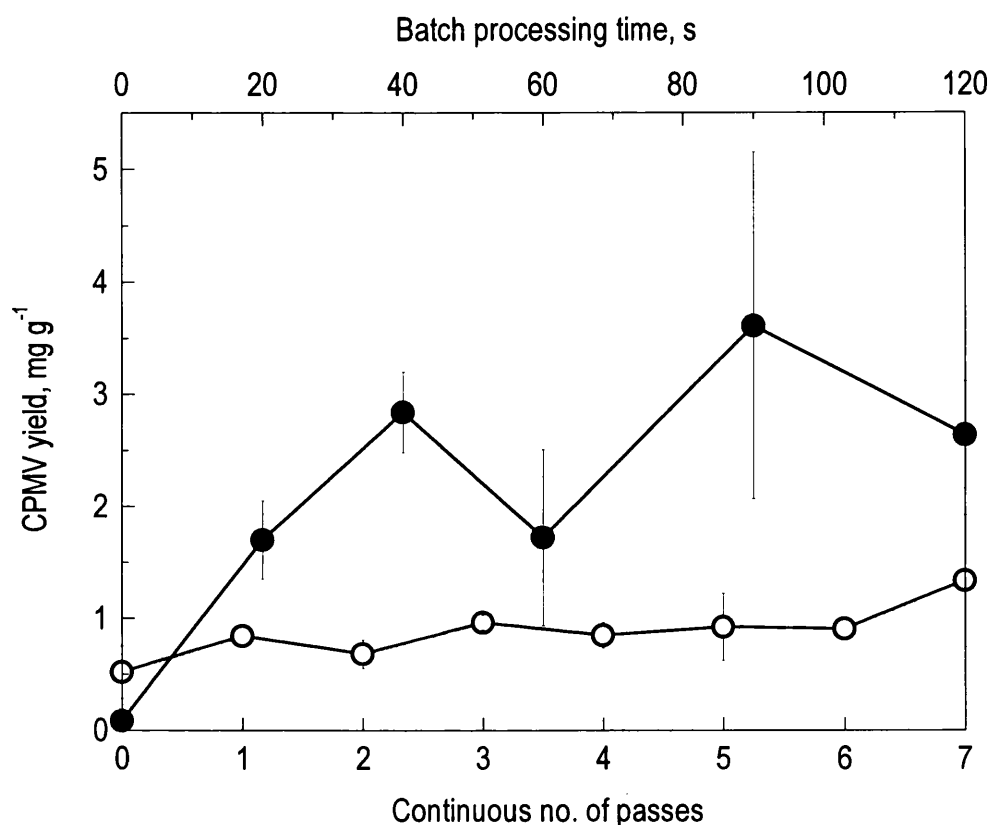

Figure 23. CPMV release from batch and continuous homogenisation.

Batch, ●; *continuous*, ○.

In batch processing the main difficulty is getting relatively large leaf pieces to be taken up into the inlet region (centre of the aggregate head), whereas in a continuous-flow setup this would present as prior blockage. In continuous, all fluid passes through once: in batch, the high processing speed should ensure the equivalent of a few hundred passes per second, but only on average, as in any 'whirl' particles can bypass processing. Continuous homogenisation of up to 7 passes offers incomplete disruption compared to less than 20s in the batch machine.

5.2.7 Scale-down Shear Device

The scale-down rotating-disk shear device was used for initial disruption of frozen, crushed leaf pieces, because the simple geometry of the processing chamber and the relatively low shear forces experienced in operation might allow characterisation of initial disruption parameters. The total yields of CPMV and of protein were assessed for various disruption conditions including pretreatment by homogenisation (complete disruption) (Figure 24).

Initial disruption in the device was incomplete. Visual inspection showed that leaf pieces were little changed, and subtle damage leading to later sap leakage was not apparent either (samples were stored without separation of solids). Running the device half-full as opposed to full did not affect yields, although there was some air interface present even during 'full' experiments. Here, frozen-thawed yields of CPMV were between 0.2-0.8 mg g⁻¹. Only 1 or 1.25 mg g⁻¹ was detected after processing at 2V and 12V respectively, which was not significantly different from the original freeze-thaw amount. After homogenisation for 5 s, 2.5 mg g⁻¹ was already available, and 3.5 mg g⁻¹ after 60 s.

For protein, the findings were slightly different. Compared to the 2 mg g⁻¹ released by freeze-thaw, 13 mg g⁻¹ was released by processing in the shear device at 2V; and at 12V, 7-9 mg g⁻¹. This overlapped with yields on homogenisation of 11-18 mg g⁻¹. So, release of protein appeared to be as high as for homogenisation, while, simultaneously, insufficient CPMV was obtained. It could be that protein was released from mainly extracellular material, while the (intracellular) CPMV was not. Therefore, since even frozen & thawed leaf pieces were not disrupted (the shear forces developed in the laminar flow pattern not being sufficient to part fibrous plant tissues), and no particular CPMV release was achieved, over the available range of performance of the scale-down shear device, it was not tested further.

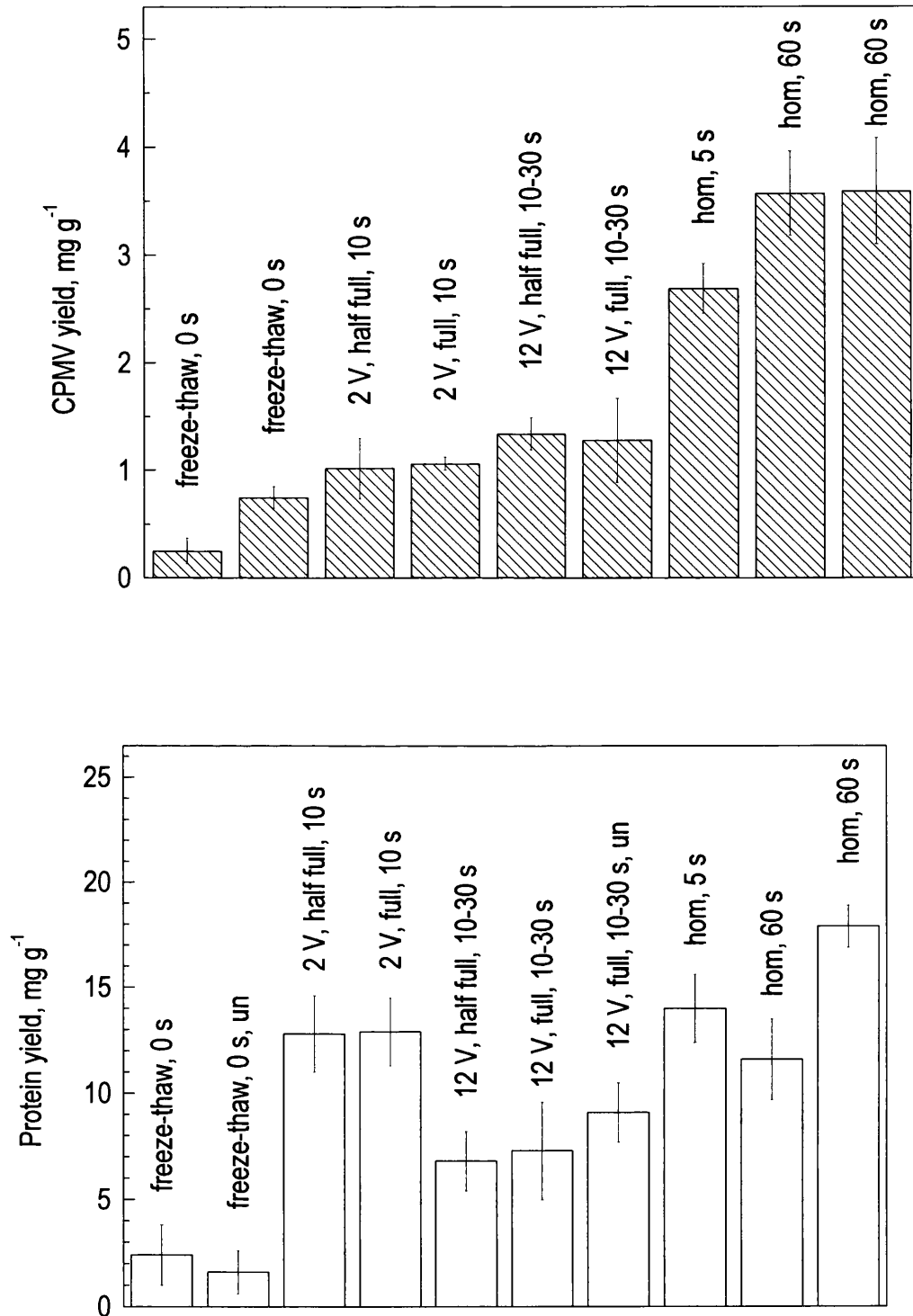

Figure 24. CPMV and protein yields in the scale-down shear device.

A: CPMV, ▨. B: protein, □. Processing times as shown; 2 V, shear device operating at minimum speed; 12 V, shear device operating at maximum speed; un, uninfected leaves used.

The results of CPMV and protein extraction using these different methods of initial disruption were compared (Table 8).

Table 8. Comparison of batch and continuous processing results.

Result	Continuous Silverson*	Batch Silverson*	Batch Silverson	Shear device
Protein yield	at most 40 mg g ⁻¹ between 1-7 passes	c. 150 mg g ⁻¹ between 20-120 s	similar between 15-240 s	13 mg g ⁻¹ at 2V; only 7 mg g ⁻¹ at 12V
Effect of dilution	none between 1/10 and 1/20	none between 1, ¼, 1/8	n.d.	n.d.
CPMV yield	up to 1.3 mg g ⁻¹	up to 3.5 mg g ⁻¹	3-6 mg g ⁻¹ between batches	up to 1.3 mg g ⁻¹ at 2V or 12V

* results of J. Martin. n.d., not determined.

5.2.8 Particle Size and Rheology

The size distribution of particles in samples, after freeze-thawing followed by homogenisation and milling, was obtained using a laser-reflectance particle sizer (MTS) and a Mastersizer2000 (Malvern). Results are given either 'by number' or 'by volume'. Particles measured by cross-sectional area are first assumed to be spherical (MTS) or irregular (Malvern), and their frequencies 'by volume' calculated; then the size distribution results transformed to results 'by number', which is less accurate but more informative for smaller particles. The smallest particles may be present in great numbers without comprising a significant total volume. A comparison of the two types of results is shown (Malvern data for homogenised material over a measurement size range of 20 nm to 2 mm) in Figure 25.

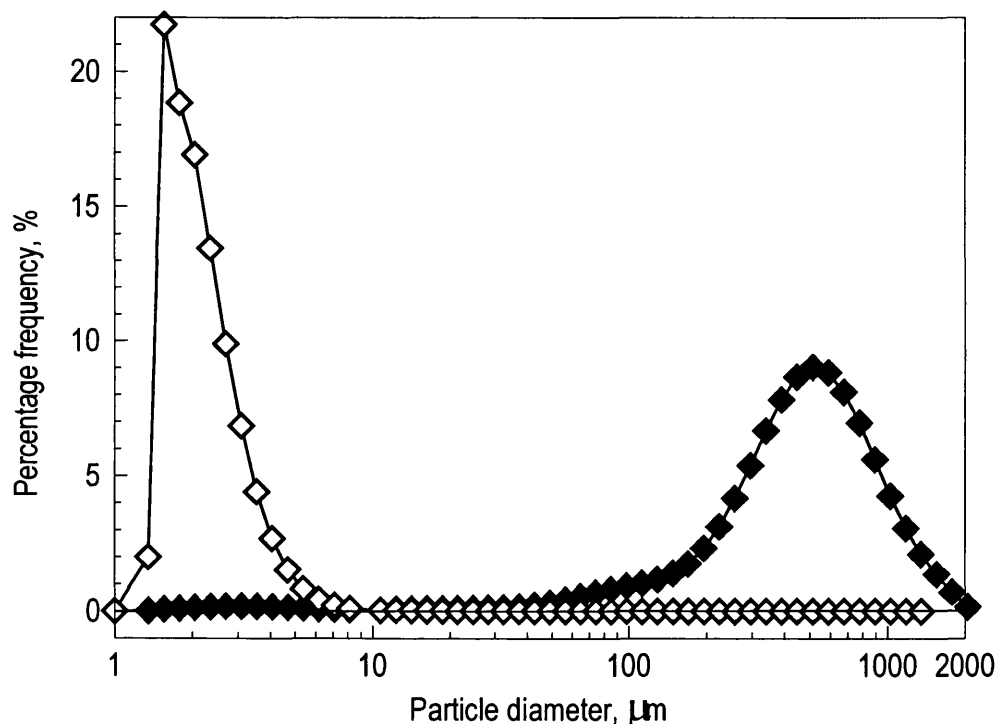

Figure 25. The same particle size distribution, frequencies by number and by volume.

By number, ◇; by volume, ◆ .

The particle size distribution and the rheological properties of the homogenate will have an important bearing on subsequent processing especially as scale increases. They are critical in determining the ease or otherwise of virus particle separation from larger insoluble contaminants.

Two major peaks at 0-1.5 μm and 7-10 μm (based on a nominal spherical particle shape) represented at least two common components, which may be spherical cell nuclei (7 μm) and

biconcave thylakoids (1-2 μm), disrupted fragments of the chloroplast photosynthetic granal stacks (MTS, data not shown). Other possible candidates are whole chloroplasts and mitochondria, which vary by species between 1 and 20 μm (Bonner and Varner, 1976). An averaged particle size distribution in the range 1-20 μm showed a peak (mode) size of 5 μm for both homogenised and milled material. The distribution for milled was slightly narrower and shifted to smaller particle sizes, which may be an artifact of dilution. Fine particles are more difficult to remove, hence undesirable when unaccompanied by a yield increase. Size reduction with homogenisation is illustrated in Figure 26.

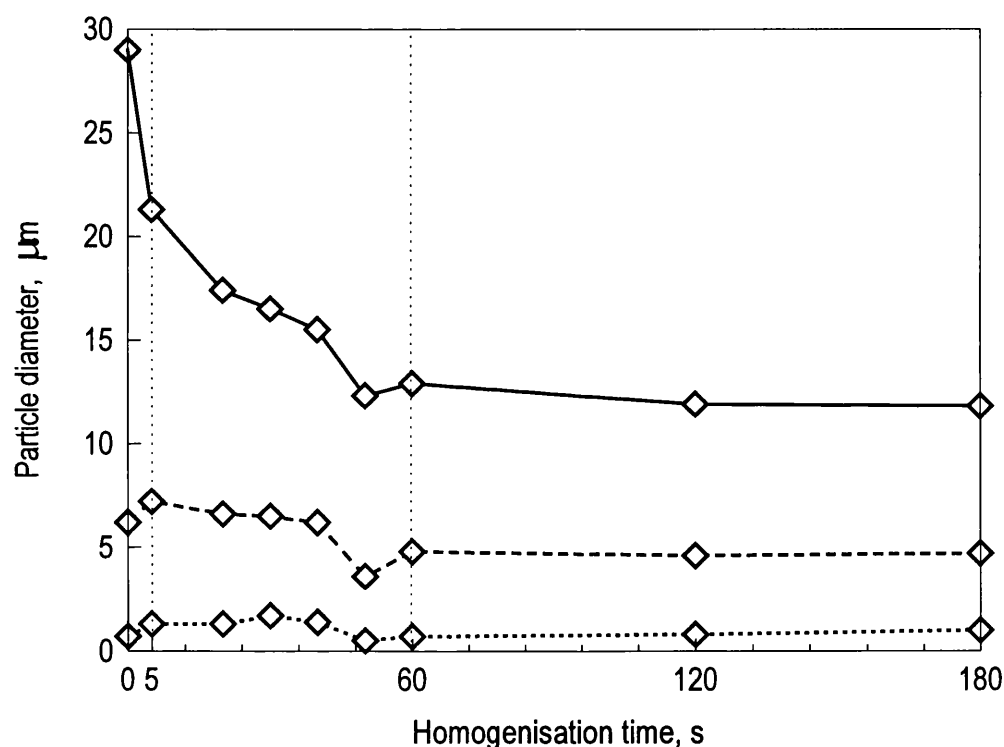

Figure 26. Change in particle size distribution with homogenisation time.

Percentages undersize by number: d_{90} , —; d_{50} , - - - - -; d_{10} , ·····.

At time zero, 90% of freeze-thawed leaf particles were less than 30 μm although larger pieces (0.25-3 mm, out of range) were present. After homogenisation for 5 s, the mulch was free-flowing and the d_{90} size was 21 μm . A steady state was reached on processing for 60 s or more: 10% of the particles were at or below the instrument's detection level of one micron, half were less than 5 μm and 90% under 12 μm . These size distributions indicate particles which could blind filters or silt out. After homogenisation for 60-180 s, maximum yields of both CPMV and protein had been achieved, in line with the maximum disruption observed; yields on further

homogenisation declined. Even after homogenisation or milling, some millimetre size fibrous fragments remained, accumulating in crevices or teeth of the disruption equipment.

Homogenised leaf in buffer (4% dry weight content) showed highly non-Newtonian flow characteristics (Figure 27); both time-dependence and shear-dependence. At very low shear rates ($0\text{-}10\text{ s}^{-1}$), the rheological data were subject to a degree of uncertainty caused by the low values of torque. An apparent viscosity as high as $400\times$ that of water (0.001 N s m^{-2}) was measured (data not shown). Between 10 s^{-1} and 200 s^{-1} , the flow curve was described well by a two-parameter power law model with a flow behaviour index less than unity indicating shear thinning behaviour. Above 200 s^{-1} , shear stress increased linearly with shear rate, at a constant apparent viscosity of 0.02 N s m^{-2} , $20\times$ that of water.

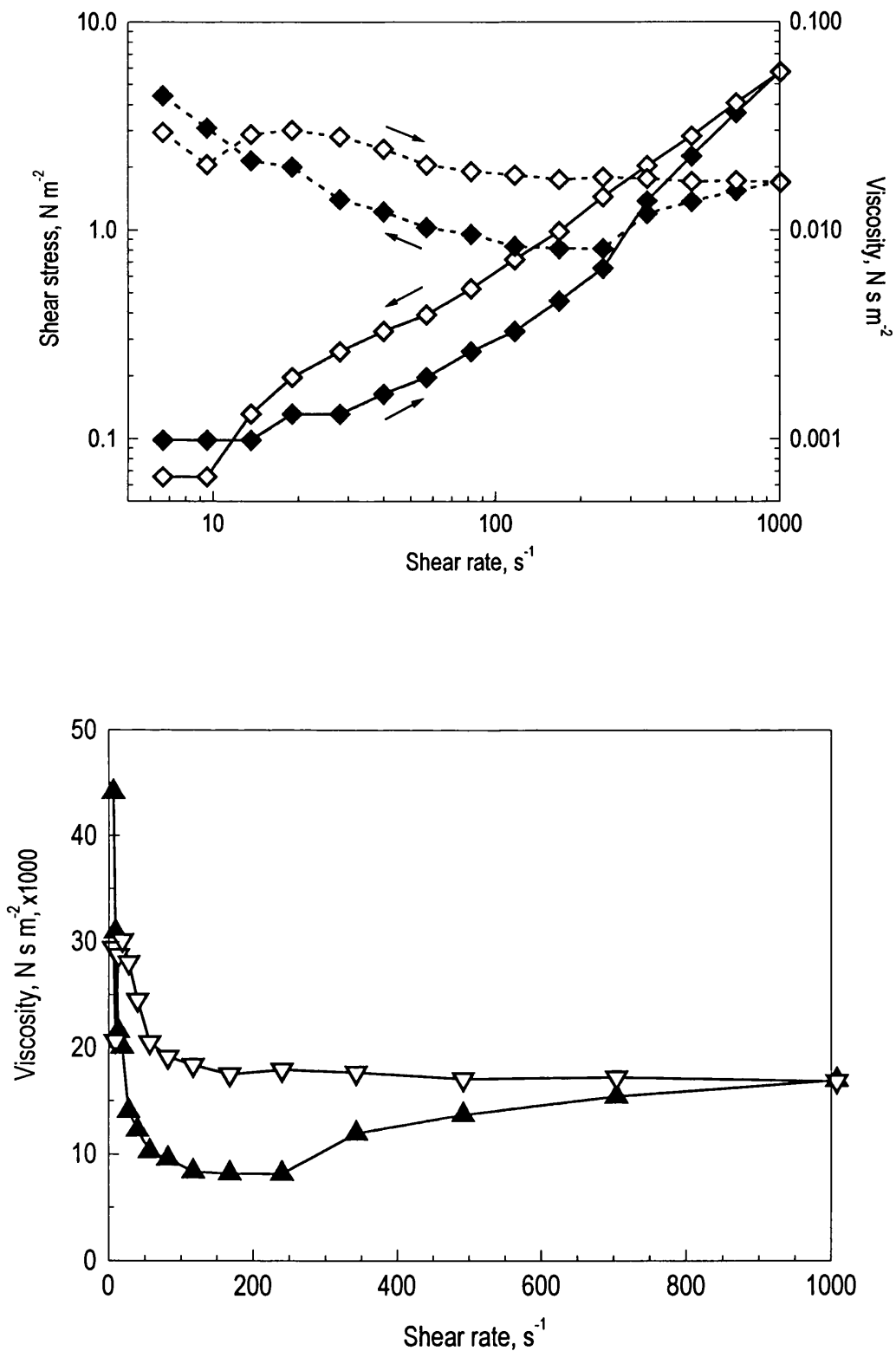

Figure 27. Rheological behaviour of homogenate under shear.

A: Logarithmic scale, Shear stress, —; viscosity, ---; increasing shear rate, \blacklozenge ; decreasing shear rate, \blacktriangleright . B: Shear-dependence of viscosity showing hysteresis, linear scale. Viscosity while increasing speed, \blacktriangle ; while decreasing speed, \triangle .

Shear stresses increased and viscosity decreased with shear rate. Shear-thinning is common in ruptured cell suspensions, due to alignment of long polymeric molecules such as nucleic acids, non-spherical organelles or particles, and macroscopic fibrous fragments from cell wall disruption. A particular feature of the rheology was the pattern of hysteresis over the range of shear rates measured. During the acceleration phase, both shear stress and viscosity were lower than during the deceleration phase. This is characteristic of thixotropic material such as disordered polymers and coiled fibres and is contributed to by particulate alignment in the fluid. Samples stirred for a longer time before measurement decreased in apparent viscosity. This could be due to sedimentation in the viscometer or time-dependent shear attrition (irreversible) of sensitive macromolecules such as DNA (Levy *et al.*, 1999).

These rheological characteristics will have profound effects on the separation and sedimentation behaviour of the process material. The immediate process implications are: potential blockages, from large particulates (as occurred with the continuous machine) and from fines settling out during transient low shear; and increased loading of the disruption motor and pumps on startup, when the fluid is also at its most solid before cell breakage. However, during normal operation flow should be smooth with a decreased power requirement.

5.3 Conclusions

A quantitative study of the release of virus from plant material has been described. There was little difference in yields between individual plants. Frozen leaves were found to be an equally useful source as fresh tissue, and thawing of frozen material significantly enhanced yields. Strikingly increased yields of CPMV, but not of protein, resulted from extending the storage time at -80°C . This may be linked to the occurrence of CPMV as cytoplasmic aggregates which might be partially dispersed by subtle thermal cycling in the freezer.

The initial disruption operation of high-shear homogenisation was chosen because equivalent industrial scale equipment is commercially available. Complete release was obtained on processing for between 5 s and 2 min. Subsequent bead milling proved to be unnecessary. Neither a continuous Silverson homogeniser nor a scale-down rotating-disk shear device produced yields comparable to the batch homogeniser.

Finally, the particle size characteristics and rheology of the resultant suspension were determined, which will be of importance in subsequent processing. Particle size distribution and rheology correlated with batch disruption measurements of CPMV and protein release: both particle sizes and yields were constant after 15 s disruption. Rheology was complex, with shear-thinning behaviour up to a shear rate of 200 s^{-1} , thought to be due to alignment of macroscopic and molecular fragments. Under higher shear conditions such as those experienced in homogenisation, viscosity was constant and flow Newtonian. Viscosity on start-up was up to $40\times$ that during high-shear processing, even for previously homogenised material. Particulate and fibrous contents of process fluid were high.

Results from these initial extraction experiments can contribute to setting recovery targets for and assessing the efficiency of downstream processing operations, to be investigated next.

6. Ammonium Sulphate Precipitation

"The universe, however, runs on processes rather than things, and a process starts as one thing and becomes another without ever crossing a clear boundary. Worse, if there is some apparent boundary, we are likely to point to it and shout 'that's it!' just because we can't see anything else worth getting agitated about." (Pratchett et al., 2000)

6.1 Introduction

Cowpea mosaic virus (CPMV) is a 28 nm icosahedral plant virus which has been genetically modified for antigen presentation and hence use as a potential vaccine (Usha *et al.*, 1993; Porta and Spall *et al.*, 1994; Dalsgaard *et al.*, 1997). Inserted epitopes up to 30 amino acids long can be displayed, 60 per particle, as extended loops on the surface coat protein. The virus efficiently replicates in the young leaves of cowpea.

Scale-down techniques have been used to develop a purification process for wild type CPMV which will be suitable for quickly evaluating the potentially more delicate modified variants as the basis for large scale production planning. As little as 2 g of leaf starting material is required per process run (Nichols *et al.*, 2001).

In the standard laboratory procedure, frozen (-80°C) infected whole leaves are crushed and homogenised in added buffer. Yields of CPMV in the homogenate vary depending on plant growth and storage history, but between 2 and 10 mg CPMV per g of leaf wet weight (mg g⁻¹) have been noted (Nichols *et al.*, 2001). The use of added buffer to reduce the viscosity of the mixture and also the release of vacuolar contents means that there is inherent dilution. For plant extracts, therefore, a product concentration step is important. As for microbial and animal cell extracts, early solids removal and selective protein fractionation are common strategies for purification (Bonnerjea *et al.*, 1986; Jervis and Pierpoint, 1989).

Scopes (1987) described ammonium sulphate as the precipitant most frequently used in the salting out of proteins. Precipitation with ammonium sulphate appeared in 43% of 100 process schemes surveyed, for complete purification from animal and microbial cell sources (Bonnerjea *et al.*, 1986). The average purification from homogenate was threefold; the highest, 12×. Low resolving power was compensated by the highest typical step yields of 81%. For purifications from various plant tissues, Jervis and Pierpoint (1989) similarly assessed 150 papers: 81% employed some form of precipitation step; 74% used ammonium sulphate as precipitant, although the average purification obtained was only twofold. They additionally highlighted the presence of tannins (reactive oxidised polyphenolics) and the need to process large volumes of dilute extract of plant material. Generally, an extraction step where necessary is followed by

filtration and/or centrifugation. They recommend ice-cold buffers and equipment, and a routine cocktail of protease inhibitors to forestall product damage. Walkey (1991) approached the particular problem of purifying plant viruses in an infective state. PEG precipitation is sometimes used, followed by salt precipitation of the virus with a one-third saturated solution of ammonium sulphate. The mixture is shaken thoroughly, allowed to stand for several hours, then the virus particles sedimented by centrifugation at low speed and resuspended. However, this regime is deemed too harsh for many viruses.

Cavell and Scopes (1976) homogenised directly at 35% (of saturation) ammonium sulphate before raising the concentration for precipitation. For small-scale operations ammonium sulphate is inexpensive, convenient and reliable and the salt exerts a protective effect on many proteins (Dixon and Webb, 1979; Scopes, 1987a), although on a large scale, a number of reasons mitigate against it (Bell *et al.*, 1983) including the need for pH control and waste disposal. In the CPMV process there was a possibility of integrating a high-salt ammonium sulphate precipitation stage with both early centrifugal clarification of homogenate, and the high-salt conditions needed for later hydrophobic interaction chromatography (HIC) column loading.

Foster *et al.* (1971, 1976) used a yeast homogenate pre-clarified by centrifugation at 34000g for 1 h before processing at 8°C. They found that dropwise addition (1 ml min⁻¹ to 10 ml) of concentrated precipitant (718 g L⁻¹, saturated at 6°C) promoted precipitation of the desired enzyme within the narrowest range of molarities, faster addition (10 ml min⁻¹) a broader profile, and solid precipitant addition an even broader range less useful for selective precipitation. A larger scale preparation of crude extract was clarified in a multichamber centrifuge. The largest precipitate particles were formed in a continuous-flow contactor, in which a helical ribbon stirrer provided efficient mixing but minimal shear at low speeds. Product concentrations reported were adjusted to the volume of original solution. Precipitating mixtures were Newtonian for shear rates up to 700 s⁻¹. Solid ammonium sulphate addition gave protein precipitates at the lowest (50-55%) percentage saturations (approximately 2M) of precipitant. The apparent solubility increased with residence time and gentler contacting. Particle size was largest for continuous mixing with saturated solution addition, then batch, solid addition, then batch, saturated solution addition. A typical volume reduction from precipitation was 10-50× for resuspended product, while precipitates were compact and stable for storage (Foster, 1994).

Richardson *et al.* (1989, 1990) presented a 'fractionation diagram' for yeast precipitation with ammonium sulphate which allowed an overall purification efficiency to be calculated and compared to an optimum. An optimisation algorithm was given for plotting the derived

purification factor against yield, taking account of pH, temperature and initial total protein concentration. Enzyme and protein concentrations were plotted per volume of initial protein solution to correct for concentration changes due to dilution by the added precipitant. Higher product concentrations gave larger, more easily recovered precipitates, but occluded product loss increased.

There has been no report on virus purification at a small scale (1-25 ml samples) by processes potentially suitable for large scale purification, nor on the detailed use of ammonium sulphate for precipitation to separate CPMV particles from leaf homogenate proteins. This study addresses the yield and purity obtainable by process routes including ammonium sulphate precipitation and low speed centrifugation steps alone or in combination. A double cut ammonium sulphate precipitation purification strategy also offers the particular advantage of concentration and volume reduction into a compact, stable precipitate, and this was quantified for CPMV preparations. In many studies on precipitation, previously clarified material is used (and often called crude extract), rather than untreated or diluted homogenate. Here, both clarified and unclarified homogenate were examined, to establish whether the prior presence of solids influences the salt concentrations at which virus and contaminants precipitate.

6.2 Results and Discussion

Initially, CPMV is present in cowpea leaf homogenate alongside other, unwanted proteins of plant origin. The homogenate can be used directly or after centrifugal clarification. After ammonium sulphate precipitation, the CPMV and protein present partition between supernatant and solids fractions. It would be convenient to keep the CPMV in solution for further processing by HIC, so a single cut strategy was first examined, in which the supernatant was taken as the product stream. Both untreated and clarified homogenates were used. This was followed by a double cut strategy, where the virus product was precipitated from this first cut supernatant.

6.2.1 Single Cut

Total protein concentrations in the supernatant and solids were measured after precipitation from homogenised leaf extracts which were either unclarified or previously centrifuged (Figure 28A). There was no net change in soluble protein between 0 and 1.0M ammonium sulphate, with a slight salting-in effect between 0 and 0.8M and a return to initial levels by 1.0M. After 1-1.2M, soluble protein began to precipitate but 0.5 mg ml⁻¹ remained in solution even at 3.1M ammonium sulphate. The profiles of precipitation from clarified and from unclarified homogenate were similar. Concentrations of protein remaining in solution, after addition of initial precipitant, agreed across three experiments of three runs each. However, concentrations of the resuspended solids separated by low speed centrifugation were more variable.

CPMV concentrations were also measured after precipitation from homogenised leaf extracts which were either unclarified or previously centrifuged (Figure 28B). CPMV precipitated in a narrower salt range than the whole mixture of leaf proteins released by homogenisation. Again, the molarity of onset, 1.0M, and the shape of the precipitation profile were comparable for both clarified and unclarified homogenate. In the supernatant, each reached the same endpoint (0.1 mg ml⁻¹ residual) by 1.4M salt.

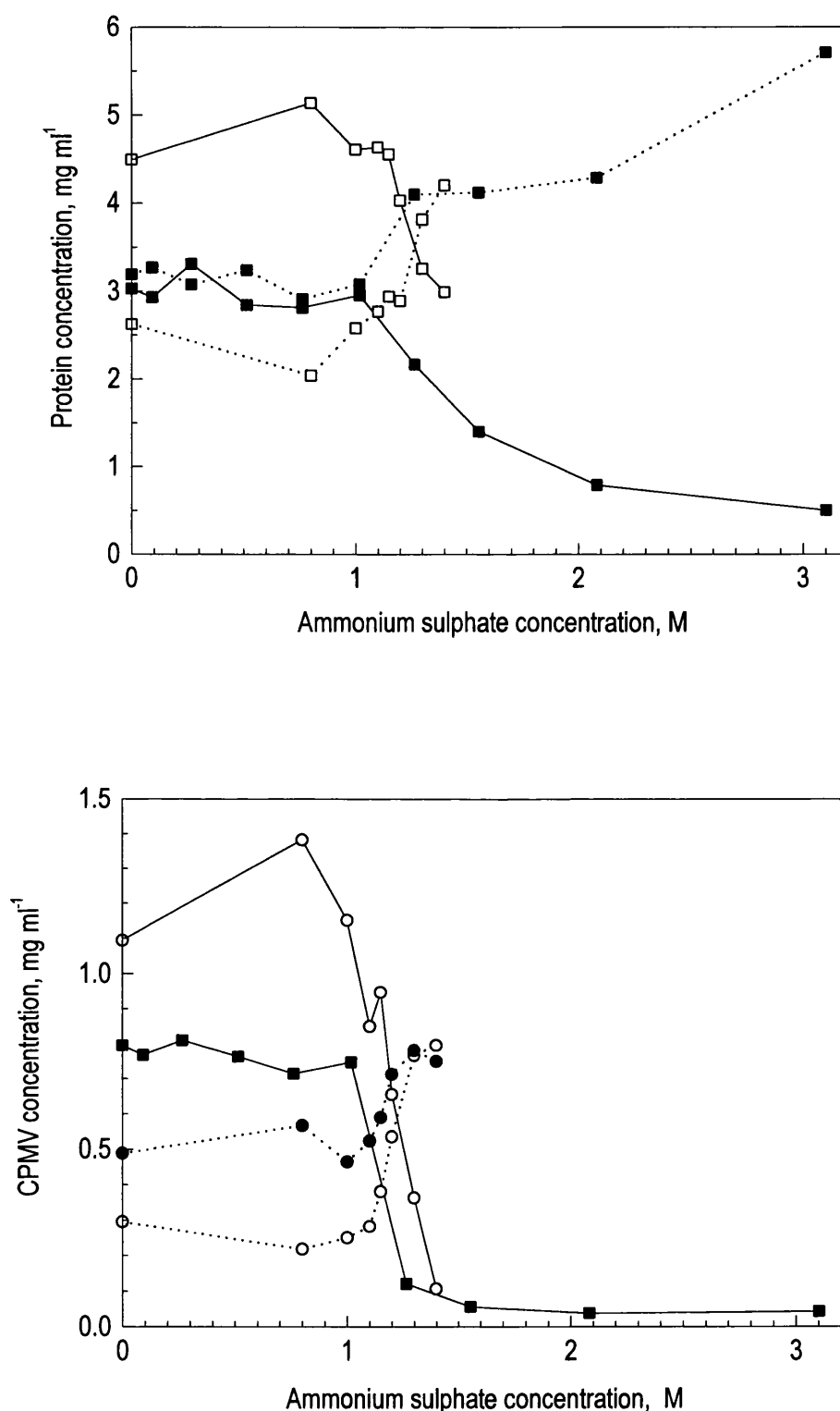

Figure 28. Profiles of single cut ammonium sulphate precipitation.

Concentrations in supernatant, —, and solids, ·····, fractions are given corrected to the original volume of unclarified homogenate. Concentrations in clarified material were higher by a factor reflecting the larger volume of unclarified extract required to make 1ml of clarified extract. A: Protein precipitation from unclarified, ■, and clarified, □, homogenate. B: CPMV precipitation from unclarified, ●, and clarified, ○, homogenate.

Amounts of CPMV or protein in solids could not be accurately determined in the precipitation range. Concentrations in clarified supernatants indicated 30% more CPMV at 0.8M than at 0.0M, attributable to salting-in. There was no discernible effect on either CPMV or protein recovery of changing the form of precipitant added from concentrated solution to crystalline solid, or of mixing at 4°C compared to ambient temperature.

Results were also calculated on a yield per unit mass basis from the original leaf wet weight, in order to determine process efficiency. For protein, 20-30 mg g⁻¹ in the unclarified homogenised extract reduced to approximately 10 mg g⁻¹ in the supernatant after precipitation at up to 1M followed by centrifugation. This did not vary with prior centrifugal clarification. As expected, solids volumes were much larger from unclarified than from clarified material despite the similarity of supernatants.

CPMV precipitation profiles on a yield per unit mass basis overlapped for all precipitations from homogenate, previously clarified or not. All supernatant yields were between a maximum of 2.7 mg g⁻¹ and a minimum of 0.1 mg g⁻¹. CPMV residues in the first cut discarded solids were unchanged between 0-1.1M but higher in unclarified (1.7 mg g⁻¹) than clarified (0.6 mg g⁻¹) extracts; however 1.3 mg g⁻¹ had already been lost during prior centrifugation of the latter. Since the minimum solids CPMV content of 1.7 mg g⁻¹ represented 63% of that in the original homogenate, it could be worth rewashing solids in-process to reclaim this redissolvable virus.

A one-step purification could make use of prior clarification by centrifugation, for a single cut precipitation with ammonium sulphate. The best precipitate by this route (at 1.4M, the maximum molarity tested), contained 1.7 mg g⁻¹ in the solid fraction (0.2 mg g⁻¹ was lost to the supernatant). It contained 8.7 mg g⁻¹ protein, giving a purification factor of only 1.6× with a low recovery of only 44% of the CPMV (from 100% in homogenate). Summed losses for clarification and first cut precipitation were 78% for CPMV and 71% for protein. However, single cut precipitation from unclarified homogenate had given losses of only 47% for CPMV but 95% for protein, both more desirable outcomes. This suggested that the presence of leaf fragments in suspension in the homogenate enhanced the precipitation of soluble protein contaminants at the first cut. The best product of single cut precipitation was a supernatant derived from unclarified homogenate.

To facilitate a more detailed analysis of the data, a fractionation diagram was constructed from the single cut (corrected) concentration data, relating CPMV and protein values directly (Figure 29A). Yields on a mass basis were also shown in this format (Figure 29B). Each point represented a different precipitant molarity condition. An operating tie-line can be drawn between the desired endpoints of recovery, and the achievable purification factor predicted from

this gradient (Richardson *et al.*, 1990). The first cut point was by definition at 100% CPMV. Second cut precipitation conditions were then predicted from the diagram (Figure 29A). For an acceptable minimum loss of CPMV of 5%, 55% of the soluble protein is predicted to be removed. As indicated by the area enclosed between the initial point and the dotted lines, it should be possible to recover from the supernatant into the solids 95% of the CPMV along with 45% of the total protein, giving a predicted purification factor between the first and second cuts of 2.1 \times . First cut supernatants from clarified homogenates yielded less (about 1 mg g⁻¹ or 8%) total protein than those from unclarified (Figure 29B). Therefore, unclarified homogenate was used for double cut precipitation.

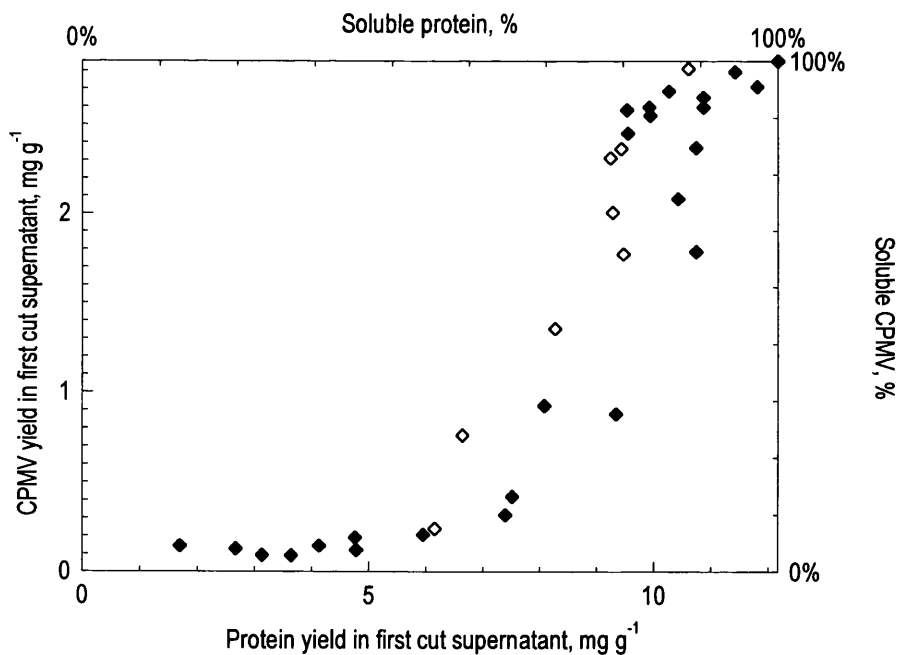
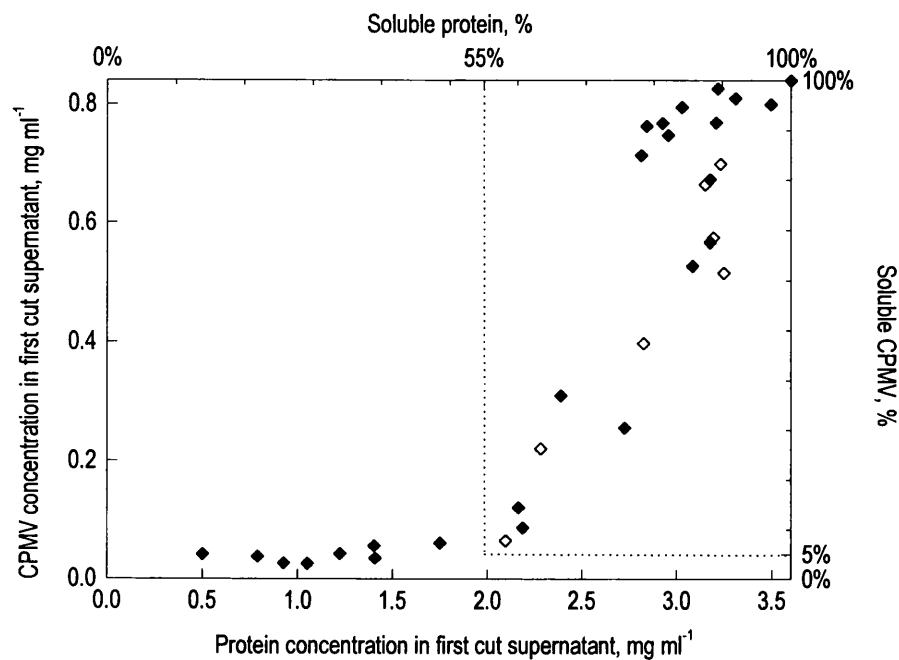

Figure 29. Fractionation diagrams comparing CPMV with protein.

A: Ammonium sulphate precipitation on a soluble concentrations basis from unclarified, \blacklozenge , and clarified, \diamond , homogenate. Percentages were based on the maximum salted-in concentrations observed of 0.84 mg ml^{-1} for CPMV and 3.6 mg ml^{-1} for protein at $0.8M$. The observed concentrations in centrifuged homogenate were slightly lower, at $0.8 (\pm 0.1) \text{ mg ml}^{-1}$ for CPMV and $3.0 (\pm 0.2) \text{ mg ml}^{-1}$ for protein. B: Ammonium sulphate precipitation on a yields per unit mass basis from unclarified, \blacklozenge , and clarified, \diamond , homogenate.

6.2.2 Double Cut

The single cut fractionation diagrams (Figure 29) indicated the potential yields (2.71 mg g^{-1} of CPMV and 5.5 mg g^{-1} of protein at 1.4M ammonium sulphate) obtainable from a double cut strategy. Conditions of a first cut at 0.5M followed by a second cut at 0.9M to comprise the 1.4M were chosen. However, it is not known how the chemical precipitant partitions between retained liquid and discarded solid phases after the first cut, and measurement of the precipitant concentration in the supernatant was difficult. Results showed that only 29% of the original CPMV was retained in the final precipitate while 75% remained in the supernatant for discard. This indicated that the second cut ammonium sulphate concentration should be increased, and implied that part of the precipitant had been removed from the first cut supernatant carried forward. An attempt to calculate this quantity from the density of the first cut supernatant via a mass balance was not accurate enough. Results indicated a supernatant molarity with respect to ammonium sulphate of between 0.11M (possible) and 1.6M (not possible).

A revised range of second cut molarities between $0.7\text{-}1.5\text{M}$ (after a first cut at 0.8M) was tested (Figure 30). The starting amounts were 5.4 mg g^{-1} CPMV and 38 mg g^{-1} protein in the homogenate reducing to 3.4 mg g^{-1} CPMV and 15 mg g^{-1} protein in the first cut supernatant, while 1.8 mg g^{-1} of CPMV and 19 mg g^{-1} of protein were removed in the first cut solids.

During the second cut, CPMV precipitated rapidly and was very low in the supernatant, 0.04 mg g^{-1} by 0.9M . Protein in the supernatant was halved, 6.2 mg g^{-1} at 0.9M , with respect to the first cut supernatant content. Considering the supernatant data the removal of 59% (more than the 55% predicted) of the unwanted protein along with only 1% (less than the 5% allowed for) of the CPMV has been achieved.

However, the yields in the solids fraction were also directly measured; more CPMV and more protein were present than originally accounted for. These final yields were measured by separate assays and replicated several times over the range $0.9\text{-}1.5\text{M}$, so may have been more reliable than those for homogenate or first cut supernatant. The CPMV yield, 4.3 mg g^{-1} , was not maximal in solids until $1.1\text{-}1.3\text{M}$, and was accompanied by up to 31 mg g^{-1} of protein.

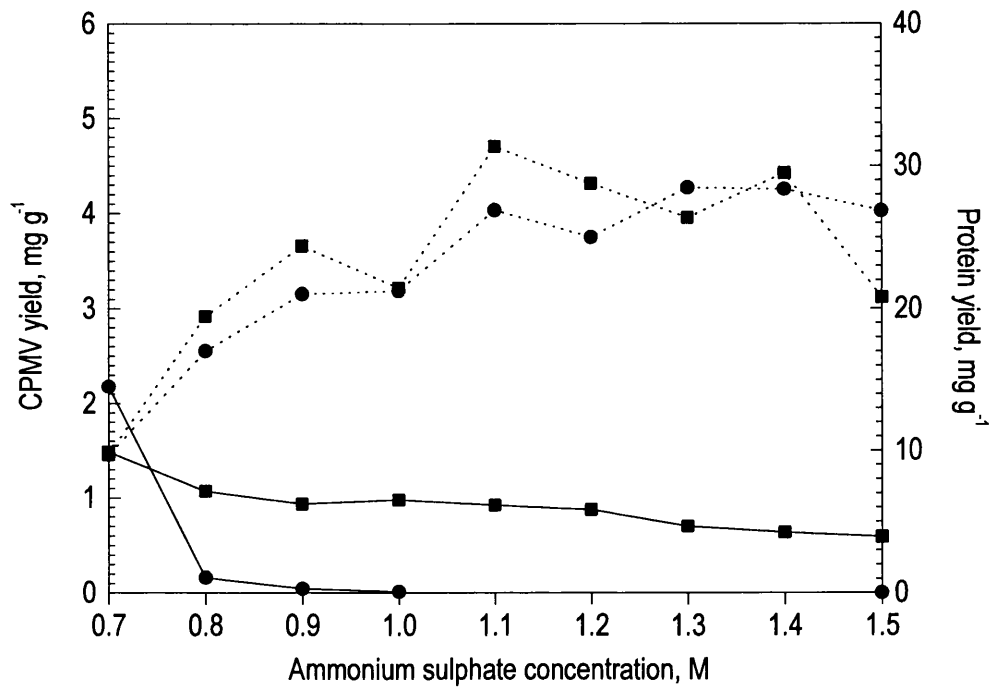

Figure 30. Double cut precipitation on a yields per unit mass basis.

Second cut purification profile for CPMV, ●, and protein, ■, recovered in supernatant, —, and solids, CPMV and protein yields from unclarified homogenate were 5.4 and 38 mg g⁻¹ respectively; 3.4 and 15 mg g⁻¹ from the first cut supernatant after precipitation at 0.8M; and 1.8 and 19 mg g⁻¹ from the first cut solids discard.

Another fractionation diagram illustrates the results (Figure 31). Compared to amounts measured in the homogenate, only 40% of the protein and 60% of the CPMV remained at the first cut. However, up to about 80% of both CPMV and protein were recoverable after the second cut, indicating no relative purification for the best yield.

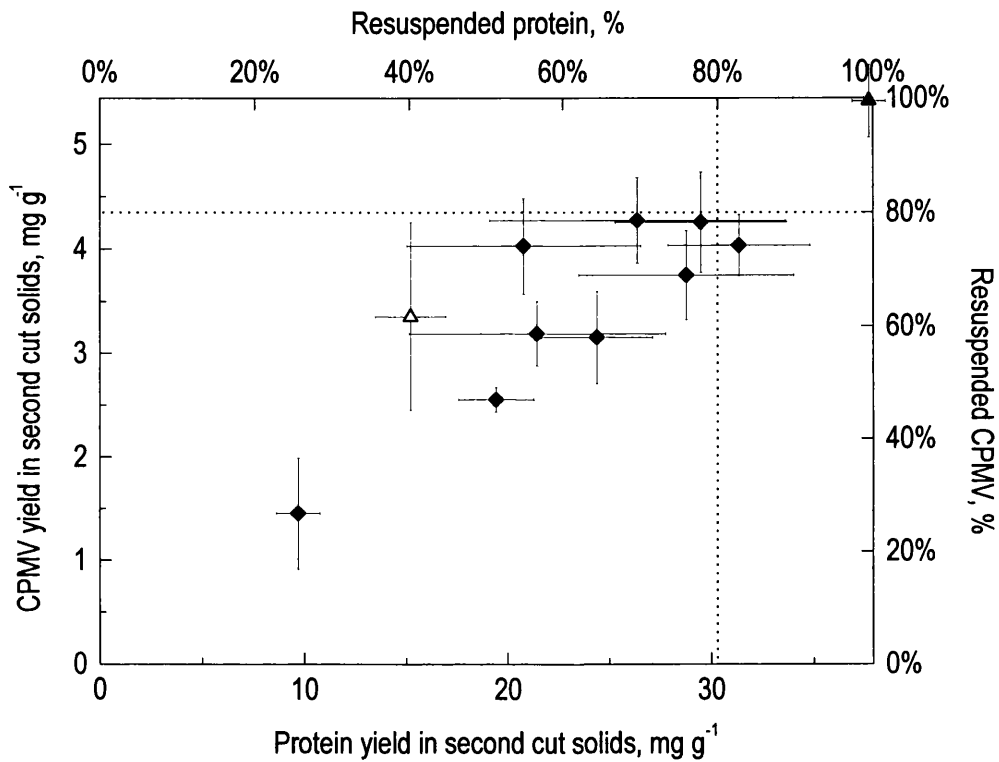

Figure 31. Second cut fractionation diagram.

Yields per unit mass at second cut, ♦, in homogenate, ▲, and in first cut supernatant, △.

In a final experiment, double cut precipitation was carried out with a first cut at 0.8M final and a second cut with added 1.2M. Starting concentrations in the homogenate were 1.2 mg ml⁻¹ of CPMV and 9.4 mg ml⁻¹ of protein. The overall CPMV yield, 3.3 mg g⁻¹, was 84% of that in the homogenate (3.9 mg g⁻¹). At the first cut, the calculated loss to solids was 22%, of which three-fifths, 13%, reappeared when the solids were resuspended. At the second cut, there was a 2% loss in the supernatant. Net purification factors were 2.1× for the first cut supernatant and 9.7× for the second cut precipitate.

The yield improvement for double cut precipitation over double centrifugation alone (where 60% of the CPMV and 30% of the protein remain in the supernatant) is 40%. On a lab scale, plant viruses are commonly purified by a double centrifugation-only strategy, but this requires extremely high speed operation to concentrate the virus particles. Such forces, of the order of 100 000g, are not attainable in continuous processing or production scale equipment.

The second cut precipitation offered a 25× volume reduction from the first cut supernatant fluid (or the homogenate) to the second cut precipitate pellet, which was resuspended in five volumes of buffer. Overall, 4 g of CPMV-infected leaf gave rise to a precipitate pellet of 0.4 g.

A summary of ammonium sulphate precipitation experiments carried out is given in Table 9.

Table 1. Details of ammonium sulphate precipitation experiments.

Experiment	AS-I	AS-II	AS-III	AS-IV	AS-V	AS-VI	AS-VII
date, leaves batch	12-15.10.98, 1	19-21.1.99, 7	8-9.2.99, 7	2-4,8-10,15-17.6.99, 7	5-7.7.99, 7	2-4.8.99, 7	16-18.8.99, 7
freezer age, d	326	134	154	268, 274, 281	301	329	343
prior processing	hom, mill, wash +/- cen	hom	hom	hom +/- cen	hom	hom	hom 2 min
disruption vol, ml x no. x reps	100 x 1	25 x 11 x 3	25 x 10 x 3	25 x 10 x 3	25 x 5	25 x 15	100 x 1
precipitant	3M with water	3.6M with Tris	solid	3.6M	3.6M	3.6M	3.6M
final molarities, M, first cut	0 0.1 0.3 0.5 0.8 1.0	0.466 1.102 1.533 1.835	0 0.092 0.266 0.514	0 0.8 1 1.1 1.15 1.2	0.5	0.8	0.8
then second cut		2.066 2.218 2.382 2.705 3.004 3.435	0.762 1.018 1.265 1.555 2.083 3.103	1.3 1.4	then +0.9	then +0.7 0.8 0.9 1.0 1.1 1.2 1.3 1.4 1.5	then +1.2
mixing time, h	0.5	18	18-24	17	17	17	17
working volume, ml	5-7.5	4-20	7-10	1-1.6	1.3-1.7	1-2	15-32
mixing vessel, ml	50	25	25	2.2	2.2	2.2	50
temperature, °C	RT	4	20	23	24	24	24
shaking, rpm	<150	150 rpm 4°C	150 rpm	200 rpm	200 rpm	200 rpm	200 rpm
CPMV in hom, mg ml ⁻¹	0.85 ± 0.13	1.268 ± 0.63	1.69 ± 0.37	1.14 ± 0.13	1.69 ± 0.4	1.59 ± 0.1	1.22 ± 0.14
protein in hom, mg ml ⁻¹	9.41 ± 0.49	7.53 ± 1.07	8.55 ± 1.1	9.2 ± 2.3	8.27 ± 1.2	11.09 ± 0.24	9.35 ± 0.12
CPMV in supt, mg ml ⁻¹	0.862 ± 0.12			1.29 ± 0.32			
protein in supt, mg ml ⁻¹	6.41 ± 0.92			7.03 ± 0.49			
CPMV max, mg ml ⁻¹ at M	0.783 at 0.8M, in supt 0.938 at 0.5M	0.769 at 0.5M	0.81 at 0.3M	0.84 at 0.8M, in supt 1.37 at 0.8M	0.98 at 0.5M	0.986 at 0.8M	0.806 at 0.8M
protein max, mg ml ⁻¹ at M	5.7 at 0.1M, in supt 6.514 at 0.5M	3.208 at 0.5M	3.309 at 0.3M	3.56 at 0.8M, in supt 5.13 at 0.5M	4.5 at 0.5M	4.47 at 0.8M	3.64 at 0.8M

Key to abbreviations: hom, homogenise/homogenate; mill, milling; wash, washing; cen, centrifuge; vol, volume; no., number; reps, replicates; supt, supernatant; max, maximum salted-in concentration.

1.1 Conclusions

Ammonium sulphate precipitation was carried out, comparing typical recoveries of CPMV and protein from untreated homogenate suspension, with those from homogenate clarified by low speed centrifugation. Clarifying centrifugation was at 5000g for 30 min, conditions readily attainable in continuous processing and at large scale.

A first cut precipitation of untreated homogenate at low molarity followed by harvesting centrifugation removed particulates and less soluble proteins. Salting-in raised the detectable concentrations of both virus and protein in solution to a maximum at 0.8M. By 1.0M, concentrations of both CPMV and protein had returned to their original levels. Approximately 95% of the CPMV was precipitated between 1.0-1.4M, while measured total soluble protein declined more slowly over this range. The partially purified virus-enriched supernatant was brought to a higher final concentration of precipitant for the second cut. This concentrated the virus into the precipitated solids phase. The volume reduction achieved was typically 25× from the homogenate to the precipitate.

There was little difference in the precipitation profiles from previously clarified compared to unclarified starting material, although the loss of CPMV to solids was greater and the removal of protein less efficient in the two-step process. Therefore, unclarified homogenate was the better starting material.

At least some of the precipitant salt preferentially partitioned and was removed as part of the first cut solids. Calculation from the density of the first cut supernatant via a mass balance indicated at least 0.11M ammonium sulphate was lost in the precipitate.

A first cut at 0.8M preserved 3.9 mg g⁻¹ of CPMV and included 32 mg g⁻¹ of protein in the supernatant which was taken forward. At the second cut, with the addition of 1.2M ammonium sulphate, 84% of the virus precipitated from solution (and was successfully resuspended). A net purification factor of 9.7× with respect to non-CPMV protein and an overall CPMV recovery of 77% were achieved reproducibly for leaves from a single batch.

7. PEG Precipitation

"But there was no use in replying, as he had already vanished round the bend of the road. When we overtook him he was climbing a gate, and was gazing earnestly into the field, where a horse, a cow, and a kid were browsing amicably together. 'For its father, a Horse,' he murmured to himself. 'For its mother, a Cow. For their dear little child, a little Goat, is the most curiousest thing I ever seen in my world!"
(Carroll, 1893)

7.1 Introduction

Cowpea mosaic virus (CPMV) is a 28 nm icosahedral plant virus which has been genetically modified for antigen presentation and hence use as a potential vaccine (Usha *et al.*, 1993; Porta and Spall *et al.*, 1994, Dalsgaard *et al.*, 1997). Inserted epitopes up to 30 amino acids long can be displayed, 60 per particle, as extended loops on the surface coat protein. The virus efficiently replicates in the young leaves of cowpea. Scale-down techniques have been used to develop a purification process for wild type CPMV which will be suitable for quickly evaluating the more delicate recombinants as the basis for large scale production planning. As little as 2 g of leaf starting material is required per process run. Frozen (-80°C) infected whole leaves are crushed and homogenised in buffer, yielding between 2 and 10 mg CPMV per g leaf (Nichols *et al.*, 2001). The use of added buffer to reduce the viscosity of the mixture and also the release of vacuolar contents means that there is inherent dilution. For plant extracts, therefore, a concentration step is particularly important. Coarse solids removal and early protein fractional precipitation are common strategies for purification.

Ammonium sulphate (salting-out) precipitation has been tested in single and double cut purification strategies for the purification of CPMV from untreated and previously clarified leaf homogenate. Results showed that an overall CPMV recovery of around 80% was reproducibly obtained, with net purification factors (protein net of CPMV) of 2.1× after the first cut at 0.8M, and 9.7× after the second cut at 1.2M additional (Nichols *et al.*, submitted 2001). Here, we present our findings from polyethylene glycol (PEG) single cut precipitation of CPMV from clarified and unclarified leaf homogenates.

Polson (1964) reported on the useful application of PEG for precipitation. PEG-6000 gives virtually no denaturation of protein products at room temperature. Selectivity is less between 2-10°C and best at around 20°C. The efficiency of protein fractionation can be described firstly by the sharpness of cut and secondly by the volumetric percentage of precipitant required. Both qualities improve as the molecular weight of PEG increases, with no further difference between 6000-20 000 kDa. In addition, higher molecular weight PEG is more viscous, so less useful.

Strict control of ionic strength was not found to be essential between 0.005-0.30M (phosphate buffer). The pH was the most critical factor affecting selectivity of precipitation from a mixture of proteins. Removal of PEG could be achieved either by non-adsorption to an ion exchange resin binding the protein of interest, with wash through; or by ethanol precipitation of protein from solution leaving dissolved PEG behind.

Foster (1973) noted that pH and protein concentration, temperature, and ionic strength were all factors affecting precipitation efficiency. The method of addition of PEG also had some effect. The lower the starting protein concentration the more PEG was required to precipitate the same proportion of product protein, usually but not always. Effective fractional separation of enzymes studied (from a cell extract mixture) was restricted to concentrations below 10 mg ml⁻¹, whereas no such limitation applied to salting-out precipitation. At high ionic strength, over 2.5N, two liquid phases were created; above 3.5N, the solid phase did not separate, and attempted precipitation segued into liquid-liquid extraction.

Scopes (1987) defined protein precipitates as aggregates of protein molecules large enough to be visible in suspension and separable by centrifugation at reasonably low *g* forces. Solubility behaviour is determined at the surface of the protein by its projecting (mostly side-chain) hydrophobic, acidic or basic groups. In a mixture, different proteins with similar properties may interact to form a heterogeneous precipitate, in which nucleic acids and solid fragments present may also be included. In very low ionic strength solutions, fine precipitates may form which are difficult to recover. A residual low level of PEG is not detrimental to many unit operations such as salting out, ion exchange, affinity chromatography, and gel filtration, allowing PEG precipitation to be used early on in a purification sequence.

Ingham (1990) summarised that PEG did not readily denature or interact with proteins even at high concentrations, up to 30%, or at elevated temperatures, so temperature control during addition was not required. Larger proteins precipitated more rapidly at lower concentrations of PEG. Solubilities typically decreased exponentially with PEG addition. Compared to ethanol or ammonium sulphate precipitation, mixture equilibration was more rapid, around 0.5-1 h at ambient temperature or in the cold. Bioaffinity additives, such as cofactors for enzymes, could be added to promote selective precipitation. Successful removal techniques included, as well as non-adsorption during ion-exchange, affinity chromatography steps, ultrafiltration or salt-induced phase separation (Polson, 1964). Ingham (1990) recommended a molecular weight for protein precipitation of at least 4000, as below this separation broadened, and not more than 6000, because of increased viscosity with little gain in efficiency. Initial experimentation might use up to 25-30% saturation (final) in 3% increments, added 1:1 volumetrically to 0.1-0.5 ml aliquots of

mixture, with a buffer to avoid PEG-induced changes in pH. For screening of pH and ionic strength effects, a 50% precipitation cutoff was suggested, as changes either way could easily be monitored.

Mahadevan and Hall (1990, 1992) put forward a statistical-mechanical model for protein-polymer and protein-protein-polymer interactions which gave a theoretical basis to many of the above observations. They added that PEG precipitation was also easily carried out on a large scale and at ambient temperatures, with relatively low concentrations of around 5-20% (w/w) being required to precipitate most proteins. There was a tendency for the polymer to contaminate the precipitate, although less so with higher molecular weight PEG.

Tsoka (2000) precipitated *Saccharomyces cerevisiae* virus-like particles (VLPs, 80 nm diameter) using PEG-6000 and PEG-8000. Lab and pilot scale experiments gave VLP yields of 85% and 49% respectively. As expected, VLP solubility declined faster than that of total protein. Halving the total protein concentration of the starting material through borax treatment did not affect fractionation. A 10% residual loss in solution was sustained on harvesting the precipitate pellet.

Hebert (1963) first reported precipitation of plant viruses by polyethylene glycol (PEG-6000). PEG at 8% in 0.2-0.3M NaCl recovered two icosahedral viruses (tobacco ringspot, 25-29 nm, and bean pod mottle, 28 nm) from a previously clarified extract. (4% PEG or lower salt solutions were less effective.) Van Kammen (1967) was the first to describe a method for preparation of CPMV using PEG precipitation. He compared precipitation by 4% (w/v) PEG-6000 in 0.2M NaCl to an older purification method, which combined solvent extraction (0.7 volumes of a 1:1 mixture of butanol and chloroform, to remove organelle membranes and pigments) and acetic acid precipitation. PEG gave better yields, of 1 mg g⁻¹. Clarification was by high speed centrifugation at 10 000-105 000g, or ammonium sulphate (to 10% saturation) precipitation of impurities.

Juckes (1971) showed that PEG-6000 precipitation occurred in a similar way to salting-out, and its selectivity was predicted to be greater for larger particles such as viruses. Proteins precipitated under conditions of temperature, pH and ionic strength in which each was stable and its solubility low, high ionic strengths being generally recommended. Brome grass mosaic virus (15 nm), for example, was precipitated by 4% (w/w) PEG in 0.03M phosphate buffer. Larger particles such as viruses are precipitated between narrower limits than smaller proteins; these limits are less dependent on protein concentration, although a high background concentration of protein does assist the precipitation of dilute virus at low ionic strength. Raising the PEG concentration at a pH to coincide with the isoelectric point minimum protein solubility can be particularly effective.

However, wild type CPMV is known to be unstable around its isoelectric point, pH 3.7-4.5 (van Kammen and de Jager, 1978). Klootwijk (1977) described a purification procedure that has remained the standard cited, in which a clarified homogenate is taken through solvent extraction before PEG precipitation, each as previously described.

7.2 Results and Discussion

Precipitation at final concentrations $4 \pm 1\%$ PEG was carried out for both unclarified homogenate and homogenate clarified by low speed centrifugation. Original amounts in unclarified homogenate were 36 mg protein per g leaf and 6 mg CPMV per g leaf. Figure 32 shows CPMV precipitation by PEG from previously centrifuged and from unclarified leaf homogenate. For precipitation fractions arising from clarified homogenate compared to those arising from untreated homogenate, virus was higher in the harvested solids but lower in the discarded supernatant.

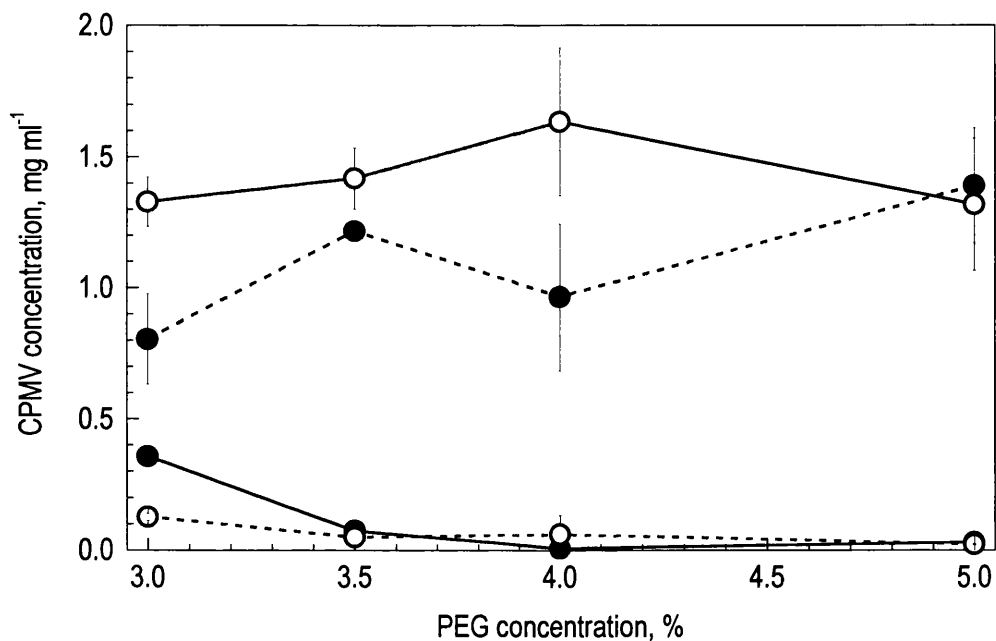

Figure 32. CPMV precipitation by PEG.

From untreated homogenate, ● ; from previously centrifuged homogenate, ○ ; in supernatant, --- ; in solids, —.

Residual protein, as shown in Figure 33, was lower in the solids and higher in the supernatant for homogenate with prior centrifugation.

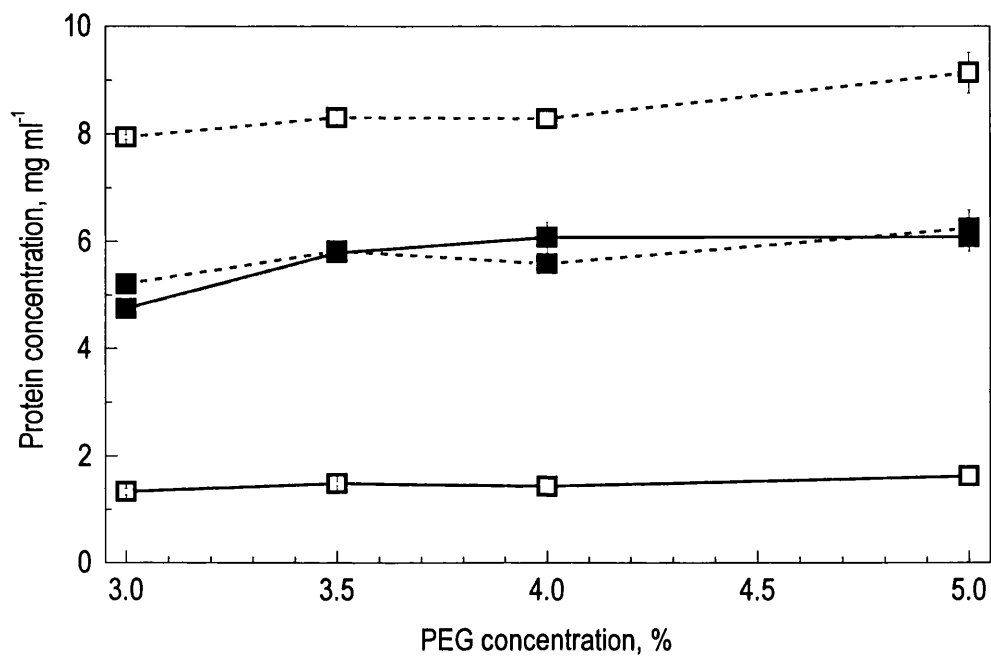

Figure 33. Total protein precipitation by PEG.

From untreated homogenate, ■ ; from previously centrifuged homogenate, □ ; in supernatant, --- ; in solids, — .

Harvested solids from clarified homogenate thus contained more product and less unwanted protein after single cut PEG precipitation and harvesting centrifugation, despite losses for both protein (60% of that in the homogenate) and CPMV (one-third) during clarification (Figure 34). Therefore, clarified homogenate was used as the starting material for PEG precipitation in further experiments. Precipitation from clarified homogenate occurred at less than or equal to 3% PEG, using less precipitant than previously reported (van Kammen, 1967; Klootwijk *et al.*, 1977).

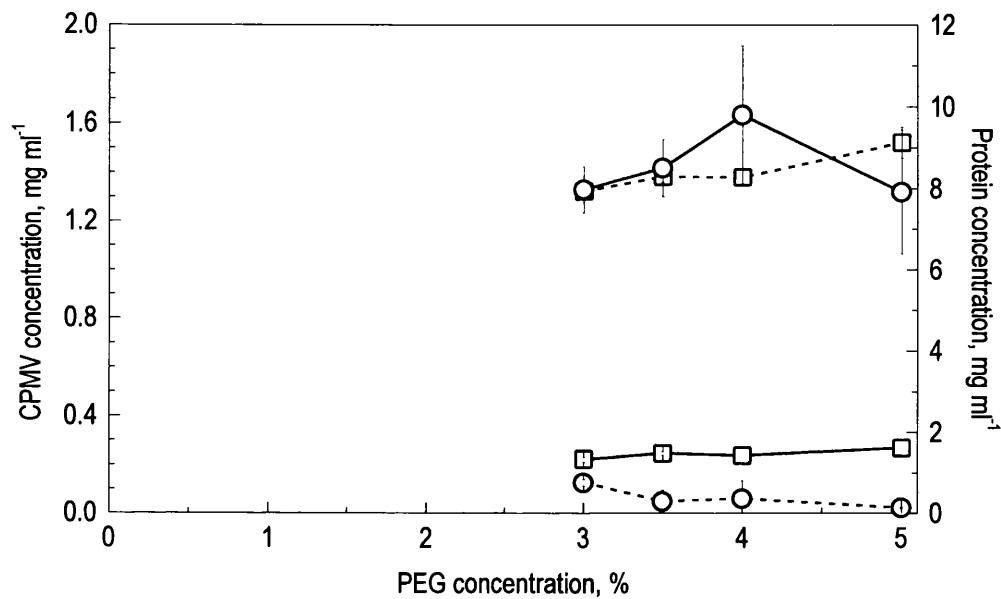

Figure 34. CPMV and protein precipitation by PEG from clarified homogenate.

CPMV, \circ ; protein, \square ; in supernatant, ---; in solids, —.

The window between 0 and 5% was looked at in more detailed increments of 0.5% PEG over three runs. Mean results for each run are shown in Figure 35 for CPMV and Figure 36 for protein (results for all runs averaged together are shown in Figure 37). CPMV partitioned between supernatant and solids during precipitation, which took place between 1 or 1.5 and 2.5% PEG in each of three experimental runs shown in Figure 35.

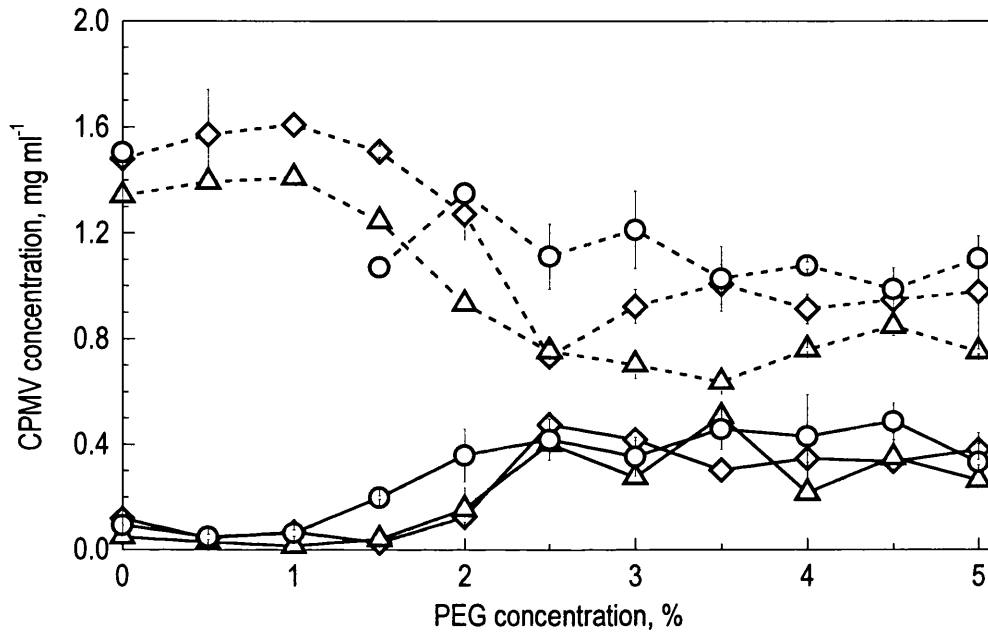

Figure 35. CPMV precipitation by PEG from clarified homogenate.

CPMV, run 1, \circ , run 2, \diamond , run 3, \triangle ; in supernatant, ---; in solids, —.

Total soluble protein, shown in Figure 36, also partitioned between supernatant and solids, but concentrations measured in both solids and supernatants increased steadily over the entire range of precipitant concentrations used. Precipitation of protein was acceptably smooth and slow, but precipitation of CPMV was not sharp and apparently remained incomplete at 0.9 ± 0.2 mg ml⁻¹ in the supernatants between 2.5-5% PEG. This level of CPMV recovery is too low for in-process use of PEG precipitation. However, results from SDS-PAGE (not shown, but similar to Figure 41 on page 109 later) confirmed that little if any CPMV remains in the supernatant at 5% PEG, when it is evident in the solids.

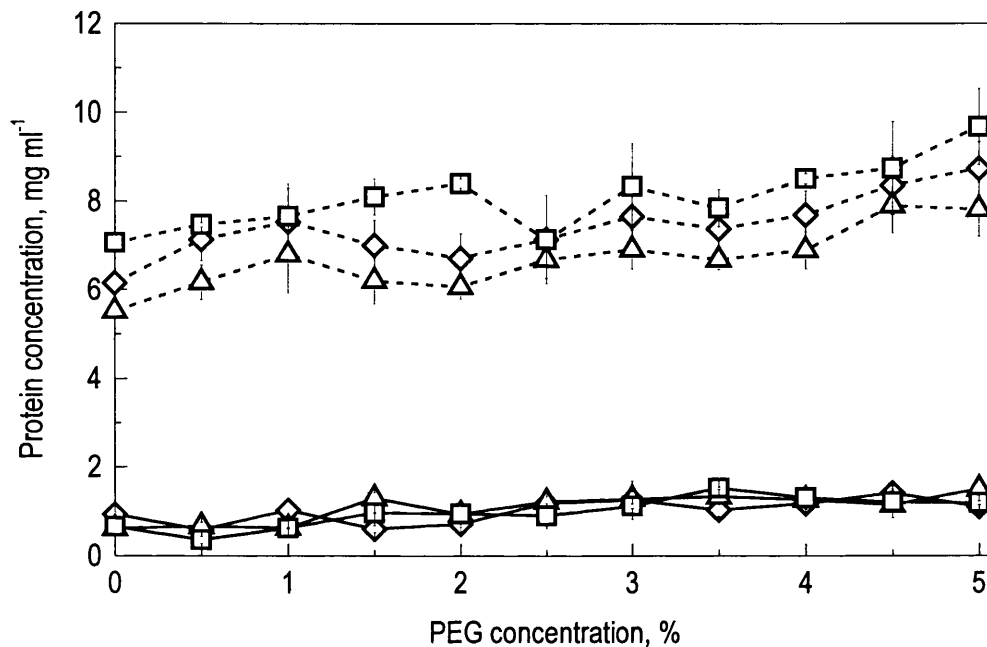

Figure 36. Total protein precipitation by PEG from clarified homogenate.

Protein, run 1, □, run 2, ◇, run 3, △; in supernatant, ---; in solids, —.

The mean results for all three runs were combined (Figure 37). The CPMV yield in the precipitate is lower than expected from initial levels in the clarified homogenate.

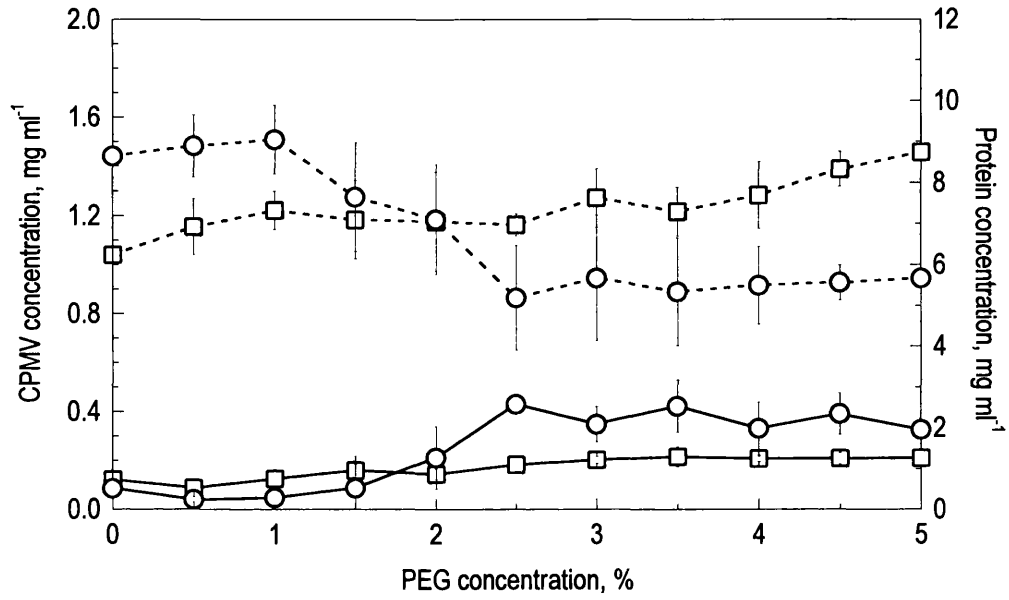

Figure 37. CPMV and protein precipitation in three runs.

CPMV, \circ ; protein, \square ; in supernatant, ---; in solids, —.

PEG precipitation from clarified homogenate to final concentrations between 0 and 25% PEG (Ingham, 1990) was further carried out, in order to elucidate the entire range of precipitant activity and determine the maximum precipitable amounts of both CPMV and protein, to confirm that sufficient separation had taken place between 3 and 5% PEG. Mean results for CPMV, shown in Figure 38A, confirmed that very little CPMV was present in solids at 0% or 2.5% PEG, and that there was concurrently little change in the CPMV concentration in the supernatant. By 5% PEG, however, complete precipitation of the CPMV had taken place, with a 92% recovery in the solids, leaving $<0.01 \text{ mg ml}^{-1}$ in the supernatant. There was perhaps a slight decline in virus content recoverable from the solids between 5 and 25% PEG, but such high concentrations of precipitant were not necessary for separation. Errors within runs were much less than variability between runs, although trends were similar. Mean results for total protein precipitation, in Figure 38B, showed very little protein in solids at 0%, but this increased steadily up to 25% PEG when, for at least two out of three runs, all that would have otherwise have been in supernatant (*cf.* supernatant content at 0%) was present in the solids. Protein contents in solids were as similar between runs as within runs. Protein concentrations in supernatants also showed a steady, net increase between 0 and 25% PEG, as before. The increase in recovery could be due to degradation and solubilization of insoluble suspended matter to detectable protein during the experiment, which might be aided by high concentrations of PEG in solution.

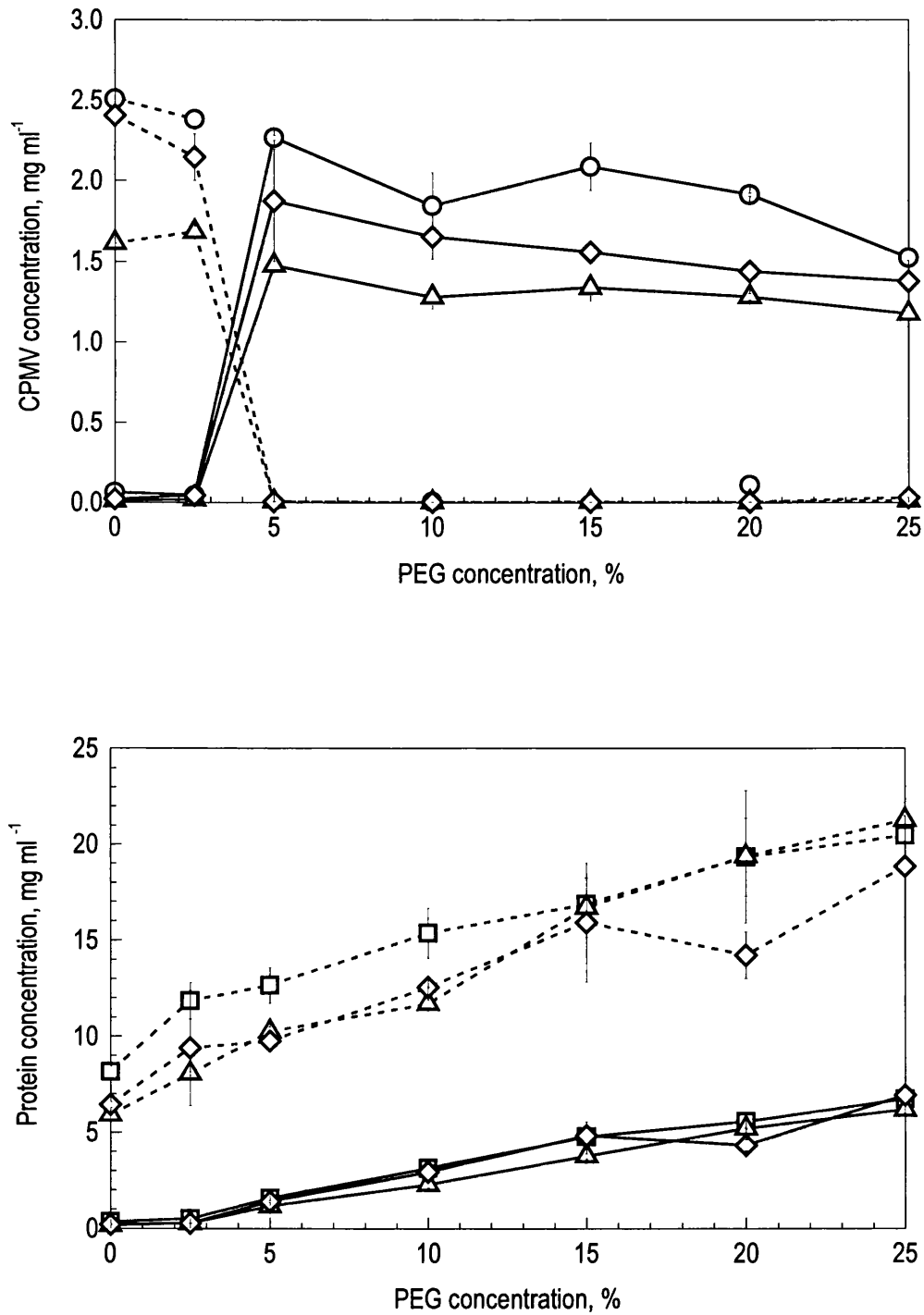

Figure 38. CPMV and total protein precipitation by PEG from clarified homogenate.

A: CPMV, ○, ◇, △; B: total protein, □, ◇, △; in supernatant, ---; in solids, —.

Again, results for all three runs were averaged (Figure 39).

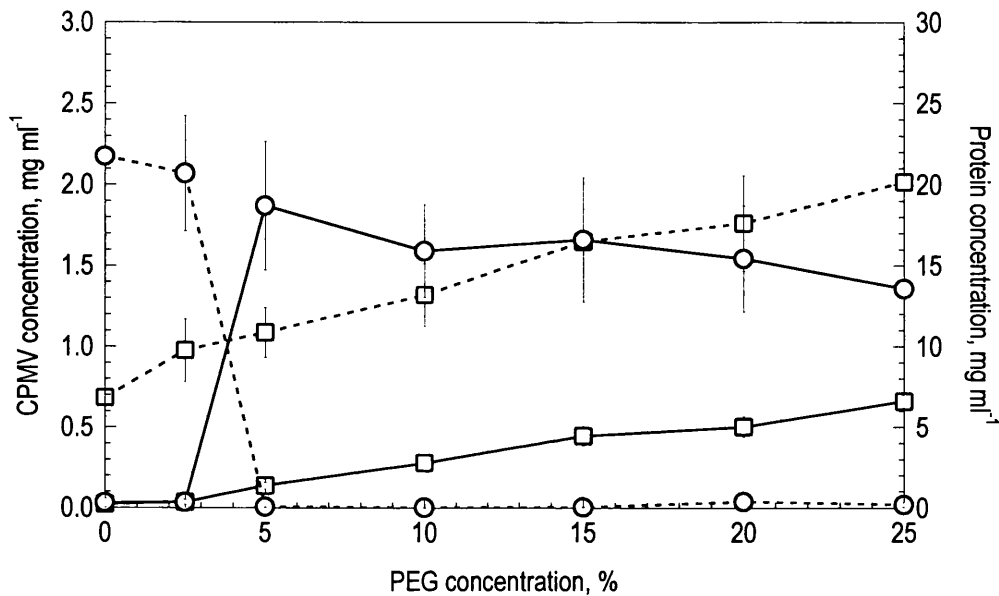

Figure 39. CPMV and protein precipitation by PEG from clarified homogenate.

CPMV, \circ ; protein, \square ; in supernatant; ---; in solids, —.

A fractionation diagram of CPMV against protein, Figure 40A, compared the concentrations of each in resuspended solids only. The plot displayed the expected sigmoidal curve from bottom left to top right, showing that CPMV in solids increased as the concentration of precipitant increased. Between 0 and 2% PEG, more of the total protein precipitated than CPMV; between 2.5-5%, relatively and absolutely more CPMV than protein; between 5 and 25%, additional protein but very little CPMV. Between 5 and 25% PEG, protein concentrations increased while CPMV stayed the same or decreased slightly.

Another fractionation diagram of CPMV against protein, Figure 40B, compared the concentrations of each in the supernatant only. The expected sigmoidal curve from top right to bottom left with increasing concentration of precipitant was not seen. Although CPMV decreased with increasing PEG concentration, protein actually increased; furthermore, the summed content of protein in both supernatant and solids together increased.

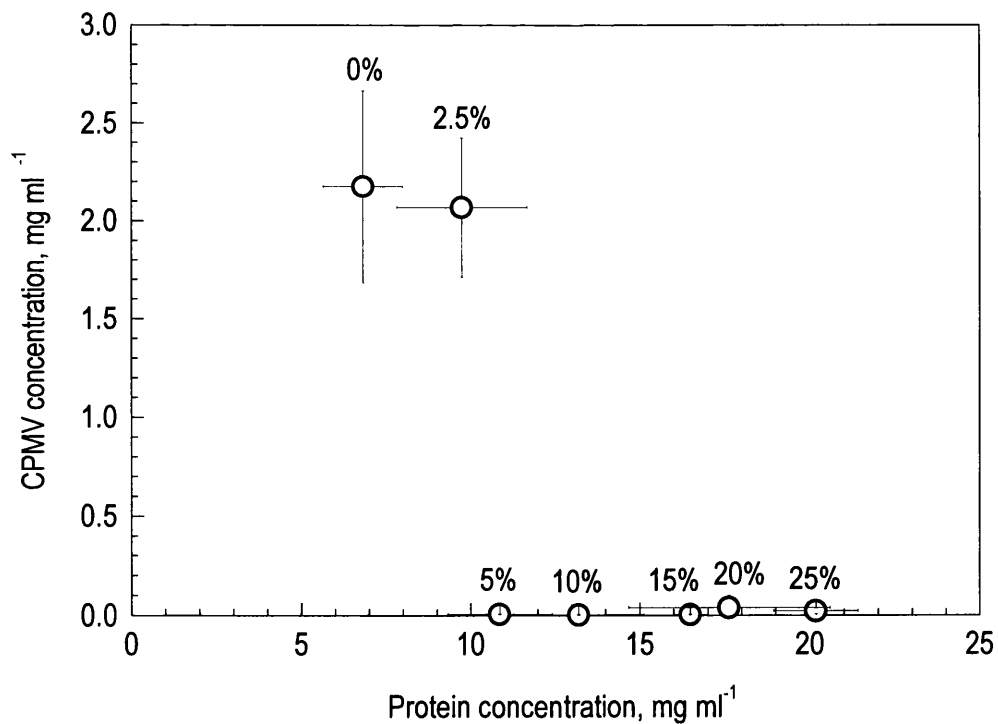
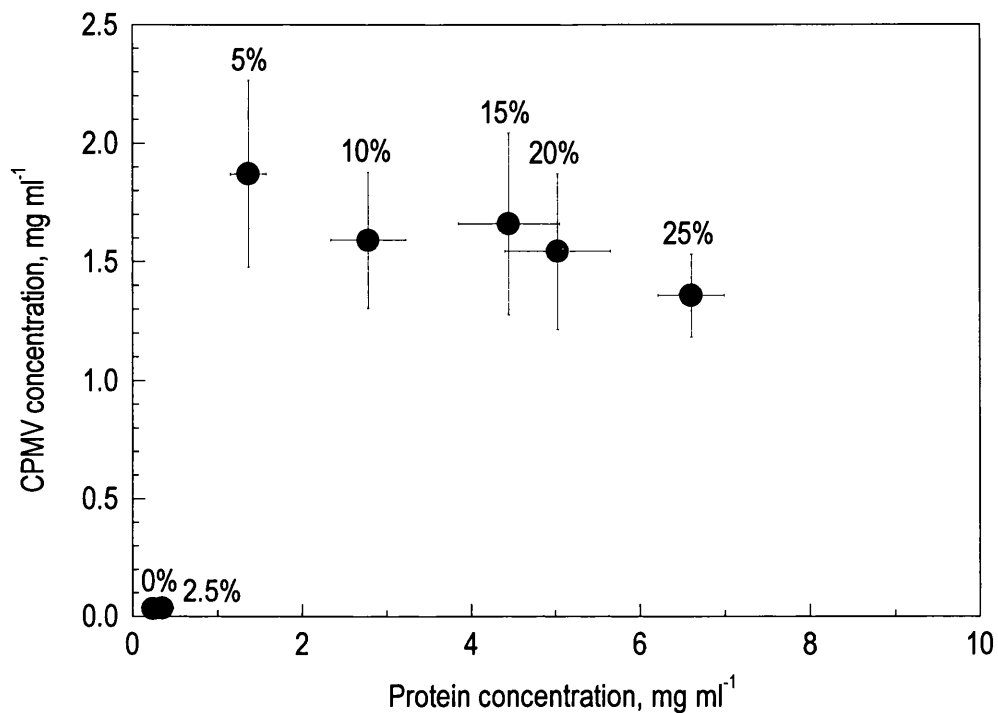

Figure 40. Fractionation diagram of CPMV against protein.

A: concentrations in resuspended solids, ●; B: concentration in supernatants, ○.

SDS-PAGE results for this experiment (Figure 41) confirmed the ELISA measurements of CPMV content in the different precipitated fractions. CPMV was still present in supernatant at 0% PEG (Figure 41A), but after that was not seen, indicating that precipitation had successfully taken place. Indeed, CPMV started appearing in solids at 5% PEG; it was there at 10%, less was there at 15%, and it was not clear if any remained at 20 and 25%. Distortion to gel bands was noticeable at 10% PEG in supernatant fractions, and between 15 and 25% PEG no bands were distinguishable.

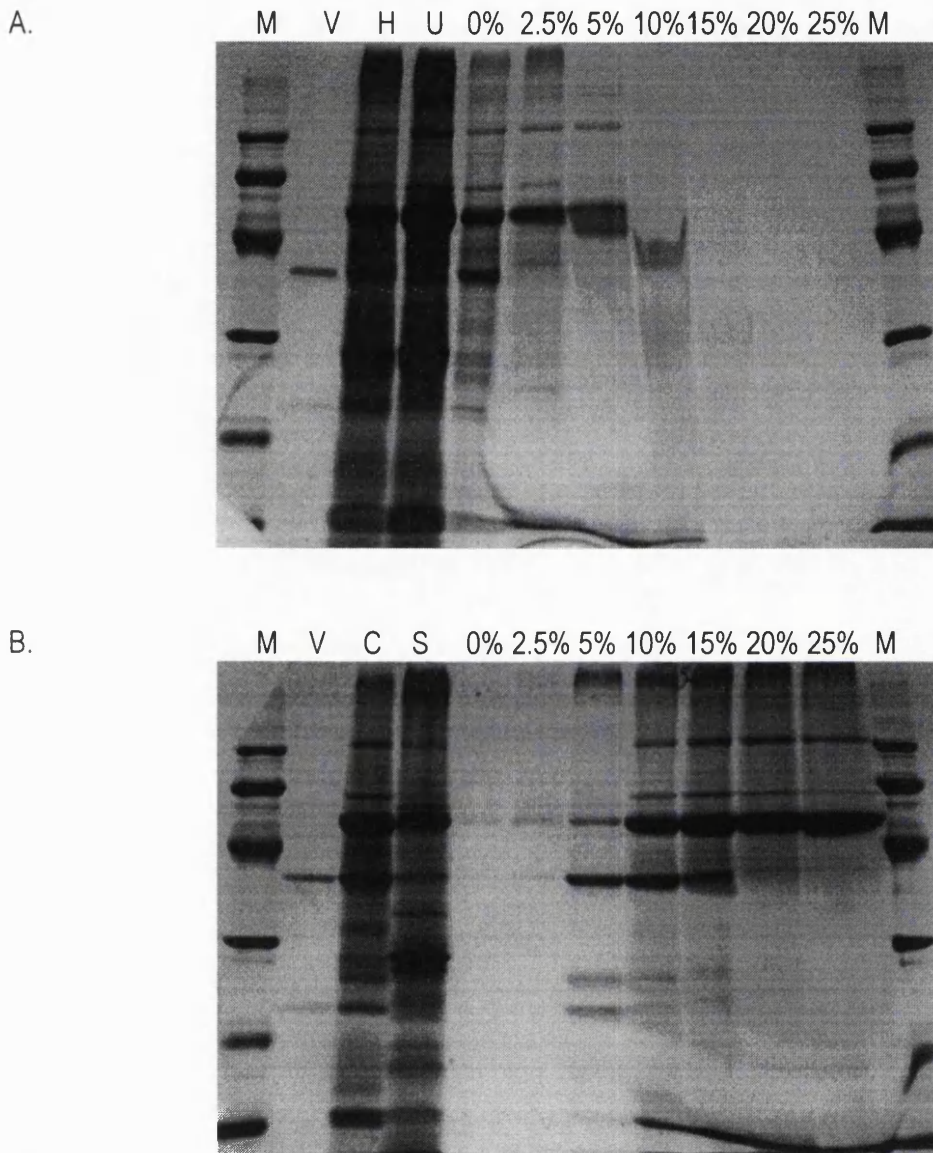

Figure 41. SDS-PAGE gels.

A: M, markers; V, CPMV standard; H, homogenate; U, homogenate from uninfected leaves with CPMV; 0-25%, supernatants after precipitation at 0-25% PEG. B: M, markers; V, CPMV standard; C, clarified homogenate; S, discarded solids from clarification; 0-25%, solids after precipitation at 0-25% PEG.

Yields and purification efficiency of CPMV against protein were calculated on a mass basis (mg per g leaf). From approximately 36 mg g⁻¹ total protein measured in the homogenate, only 15 ± 3 mg g⁻¹ was present in clarified homogenate, the starting material for PEG precipitation. After precipitation using 5% PEG, 22 ± 3 mg g⁻¹ was removed in the supernatant, 140% of that after clarification. In the pellet, only 18% remained, 2.7 ± 0.4 mg g⁻¹. For CPMV, 6 ± 0.1 mg g⁻¹ was present in the homogenate, reduced to 4 ± 0.9 mg g⁻¹ by clarification. During precipitation, only 0.3%, 0.013 mg g⁻¹, was lost in the supernatant, while 92%, 3.7 ± 0.8 mg g⁻¹ was recovered in the pellet. Therefore, purification factors (see 3.6.2 Purification Factors for calculation) were 5× for clarified material to pellet; 8× from homogenate to pellet. However, the complete amount of soluble protein measured in the pellet can be accounted for by CPMV, indicating a successful purification. A reduction in volume of 20× between the clarified homogenate and the pellet, or 10× from the frozen leaf to the pellet, was an associated benefit.

A summary of experiments carried out is given in Table 10.

Table 10. PEG experimental details.

Dates	Freezer age of leaves, d	Conditions		Starting concentrations, mg ml ⁻¹			
		starting material	% PEG	CPMV in hom	CPMV in clar	protein in hom	protein in clar
19-21.10.99	529	hom, clar	3-5%: 3,3.5,4,5				
06.12.99*							
14.12.99, 17.01.00, 24.01.00	585-626	clar	0-5%: 0,0.5,1.0, 1.5, 2,2.5,3,3.5, 4,4.5,5	1.7	1.5	9	7
03.04.00, 10.04.00, 17.04.00	696-710	clar	0-25%: 0,2.5,5, 10,15,20,25	2.0	2.0	7	7

*not used. Hom, homogenate; clar, clarified homogenate. All protein assays same day, ELISA +1 d, gel +2 d. Homogenisation scale 2g+5ml, clarified homogenate pH 6.5-7.0. Precipitate mixing/conditioning for 1 h at 150 rpm.

7.3 Conclusions

CPMV was precipitated completely out of the supernatant and into the solid phase between 2.5 and 5% PEG. Protein, meanwhile, appeared more slowly in solids as well as appreciably increasing in concentration in supernatants over this range, continuing in both trends between 5 and 25% PEG.

From unclarified starting material the colloidal system was expected to cause problems with PEG reproducibility, precipitating both protein and virus by nucleation on suspended solids. Clarified homogenate was found to give more reproducible and effective precipitation. However, precipitation performance then seemed straightforward and comparable to salting-out.

Yields from PEG precipitation from clarified homogenate may be compared with the previous results for ammonium sulphate double cut precipitation from untreated homogenate. Overall, 61% of the CPMV in untreated homogenate was recovered in the final PEG-precipitated pellet. Most of the loss was due to clarification: 92% of the CPMV in clarified homogenate was recovered in the pellet.

For ammonium sulphate precipitation, recoveries of 80% were reproducibly obtained, with a recovery of 150% achieved between the comparable first and second cuts. A net purification factor of 9.7 \times was obtained for ammonium sulphate precipitation (from homogenate to pellet); while, using PEG, apparently all of the residual protein in the pellet could be accounted for by CPMV. This advantage in purity would have to be balanced against the reduction in overall yield when the prior clarification step is considered. The volume reduction (25 \times with ammonium sulphate, 20 \times with PEG) from homogenate to pellet was another useful feature of precipitation early in the purification process.

8. Wild Type & Recombinant

“ ‘So would you say that the issue [labelling of nutraceuticals] will be decided by legislation?’ ‘That’s the way we do things in the States - either litigation or bombing!’ ” (Dahlman, 1999)

8.1 Introduction

Wild type CPMV had been used for processing experiments in order to investigate scale-down techniques of disruption for initial extraction, and then useful methods of front end downstream processing for plant extracts. At the time these experiments were started, there was not a sufficient supply of recombinant CPMV-containing leaves to allow work to be carried out with the potentially clinically useful variants directly. Once scale-down techniques had been developed and tested, the high-value recombinants could be used on a small scale to give useful process data.

Process conditions were selected from those which had given the best performance in processing wild type CPMV. The aim was to apply these to processing the recombinant CPMV side-by-side with the wild type, in order to investigate whether the same methods would be applicable, and therefore whether initial process development could in the future be usefully carried out using the more readily available and easily handled wild type virus. In the latest review of CPMV-based vaccines, no mention was made of process design for CPMV purification, wild type or recombinant (Brennan *et al.*, 2001).

8.2 Methods

The methods used are here briefly described to aid interpretation of the results which follow.

8.2.1 Processing

Double cut ammonium sulphate (AS) precipitation used untreated homogenate of infected leaves as the starting material (Figure 42). Mixing was overnight for each step. Single cut polyethylene glycol (PEG) precipitation used previously clarified (low speed centrifuged) homogenate (Figure 42). Mixing was for 1 h.

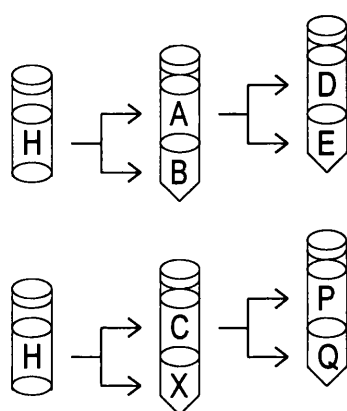

Figure 42. A simplified process flow diagram.

Homogenate H is either directly precipitated with ammonium sulphate, giving supernatant A and solids B, and the first cut supernatant precipitated again, giving supernatant D and precipitate E; or clarified, giving supernatant C and solids X, and the clarified supernatant precipitated with PEG, giving supernatant P and solids Q.

8.2.2 SDS-PAGE

Solids fractions from centrifugation, e.g. X (Figure 42), were resuspended in Tris-HCl buffer before sampling, e.g. X1. For sodium dodecyl sulphate (SDS) polyacrylamide gel electrophoresis (SDS-PAGE), samples were denatured by boiling with SDS and mixed 1:1 with loading buffer with no additional dilution, equal volumes (10 μ l) of each being loaded. CPMV standards were loaded at 2 μ g per well. 12.5% acrylamide main gel mini gels were stained with Coomassie blue and digitally photographed.

Gel markers' molecular weights are: 97, 67, 43, 30, 20.1, 14.4 kDa. Wild type CPMV coat proteins' subunit molecular weights are: L, 37 kDa; S, 23 kDa. Mucin epitope insertion increases the muc14-CPMV's S coat protein molecular weight by 60 \times the insert size. However the virus coat proteins are known to run anomalously on gels, giving (reproducibly in experiments at both Axis with muc1 and UCL with muc14) a predicted molecular weight of 41 kDa for each of the wild type and recombinant large coat proteins, when their actual sizes are 37 kDa. (These

variations may be due to shape, rigidity, charge distribution, etc.) Similarly, the actual size of the muc14-CPMV small coat protein may be smaller than its apparent size in SDS-PAGE.

Recombinant constructs based on the CPMV small coat protein are subject to a characteristic cleavage event which removes all but one amino acid of the inserted epitope along with the N-terminal 22 amino acids of the small coat protein. Thus multiple bands are often seen for the shortened S protein (the cleaved fragment is very small and runs off the gel).

8.3 Results

Selected results for CPMV (measured by ELISA) and total protein concentrations are given uncorrected, rounded to 1 significant figure (wild type, Table 11; recombinant, Table 12). Volume ratios (conversion factors) enable these results to be compared between samples. Dilution factors refer to resuspended solids fractions which have been diluted with resuspension buffer. For the comprehensive results from which these data were taken, see Figure 45 on page 145 for wild type and Figure 46 on page 147 for recombinant.

Table 11. Wild type CPMV purification values.

Sample	Description	Volume ratio	Dilution factor	CPMV, mg ml ⁻¹	Protein, mg ml ⁻¹
H	homogenate	1		2	10
C	clarified homogenate	0.75		2	6
X1	clarified resuspended solids X	0.68	2.7	0.8	7
A	AS first cut supernatant	0.5		0.8	5
B1	AS first cut resuspended solids B	1.2	1.5	0.5	7
D	AS second cut supernatant	0.7		0.01	1
E1	AS second cut resuspended precipitate E	0.15	3	3	6
P	PEG supernatant	1.49		0.0001	7
Q1	PEG resuspended precipitate Q	0.79	18	1	2

Table 12. Recombinant muc14-CPMV purification values.

Sample	Description	Volume ratio	Dilution factor	CPMV, mg ml ⁻¹	Protein, mg ml ⁻¹
H	homogenate	1.0		2	10
C	clarified homogenate	0.78		2	6
X1	clarified resuspended solids X	0.68	2.4	0.8	7
A	AS first cut supernatant	0.73		0.8	5
B1	AS first cut resuspended solids B	0.84	1.9	0.5	7
D	AS second cut supernatant	1.02		0.01	0.9
E1	AS second cut resuspended precipitate E	0.22	3.0	3	6
P	PEG supernatant	1.57		0.002	7
Q1	PEG resuspended precipitate Q	0.87	9.3	1	2

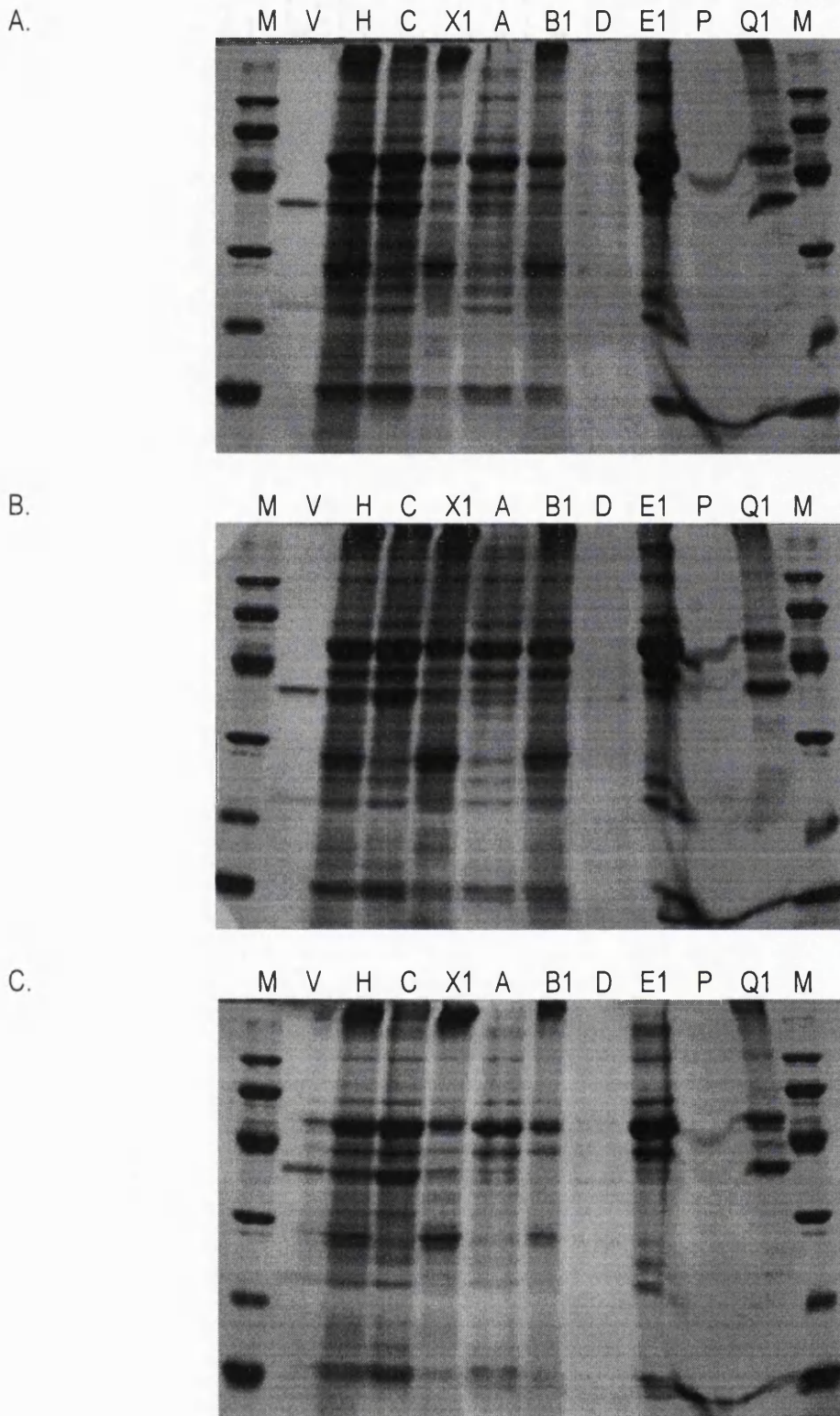

Figure 43. Wild type CPMV purification by precipitation.

Results from three replicate runs are shown on separate gels (A-C). M, markers; V, wild type CPMV standard; H, untreated homogenate; C, clarified homogenate; X1, resuspension of solids discard from clarification; A, supernatant from first cut ammonium sulphate precipitation; B1, resuspension of solids discard from first cut ammonium sulphate precipitation; D, supernatant discard from second cut ammonium sulphate precipitation; E1, resuspension of solids product from second cut ammonium sulphate precipitation; P, supernatant discard from single cut PEG precipitation; Q1, resuspension of solids product from single cut PEG precipitation.

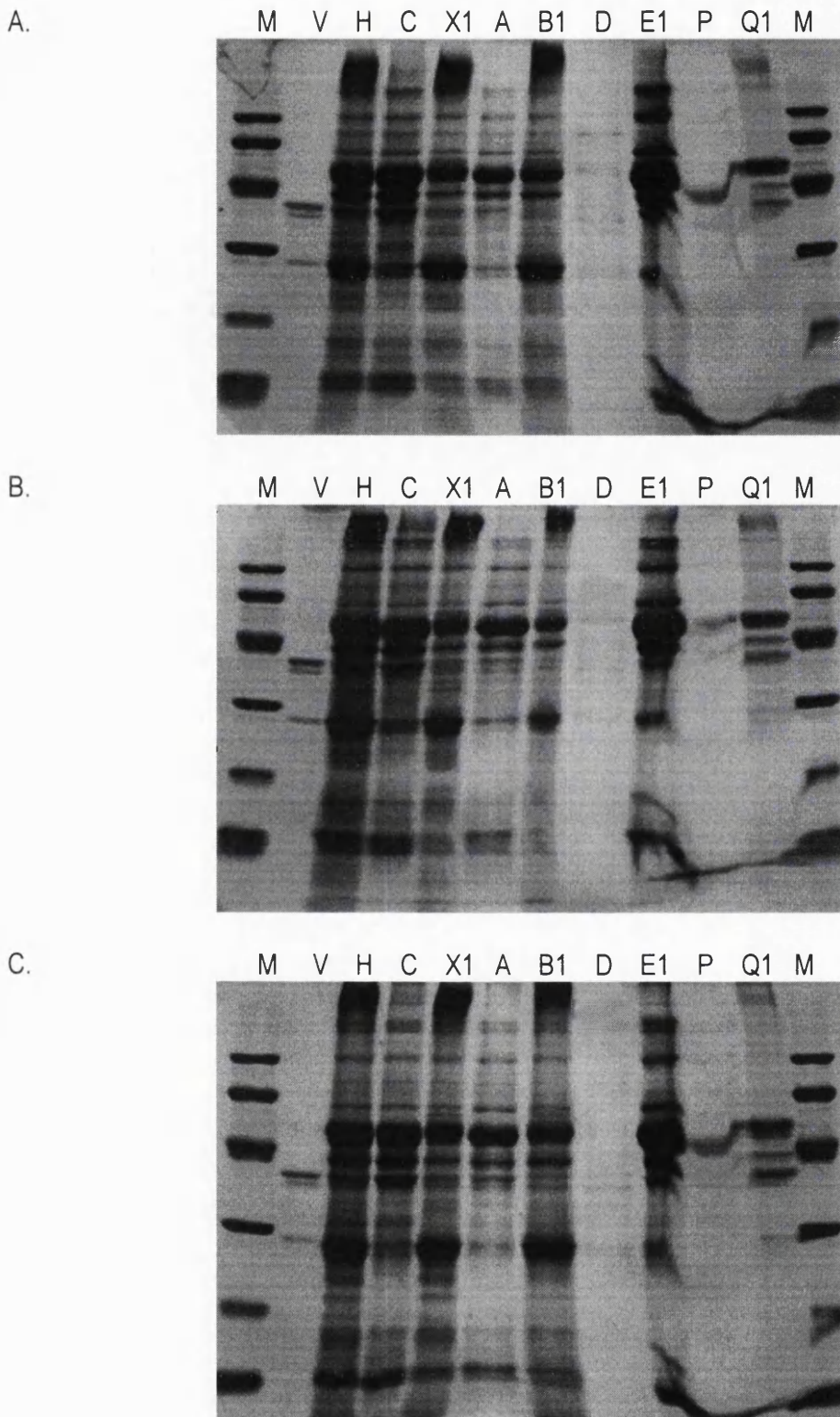

Figure 44. Recombinant muc14-CPMV purification by precipitation.

Results from three replicate runs are shown on separate gels (A-C). M, markers; V, wild type CPMV standard; H, untreated homogenate; C, clarified homogenate; X1, resuspension of solids discard from clarification; A, supernatant from first cut ammonium sulphate precipitation; B1, resuspension of solids discard from first cut ammonium sulphate precipitation; D, supernatant discard from second cut ammonium sulphate precipitation; E1, resuspension of solids product from second cut ammonium sulphate precipitation; P, supernatant discard from single cut PEG precipitation; Q1, resuspension of solids product from single cut PEG precipitation.

8.4 Discussion

8.4.1 Wild Type

The major protein impurity (typically 40% of total leaf soluble protein) was the chloroplast photosynthetic enzyme ribulose biphosphate carboxylase/oxygenase (RuBisCO). This 560 kDa protein has 56 and 14 kDa subunits which are dissociated by SDS treatment (during the SDS-PAGE assay). These bands showed up clearly in fractions H, C, X1 (large subunit only), A, B1, E1 and Q1. The impurity was therefore present in the homogenate and clarified homogenate, with some in the discarded solids from clarification. In the concentrated first cut supernatant from ammonium sulphate precipitation (A), it was still evident but less, even in the 0.15 volume ratio sample, because of losses to solids (B1). From this supernatant it was more concentrated in the second cut solids product (E1), with none apparent in the complementary supernatant (D). Similarly, very little appeared in the PEG supernatant (P); it remained in the PEG solids product (Q1). Thus the major contaminant protein was reduced by both types of precipitation, although not completely cleared.

The total protein contaminant load, as evidenced by dark staining spanning a range of molecular weights, was greatest in the homogenate and remained high in clarified homogenate. Although the background appeared high in the ammonium sulphate product precipitate, this sample was very concentrated (0.15 volume ratio) and the total process load had probably been considerably reduced. Protein assay results were a reliable quantitative indicator.

The two (L and S) CPMV coat protein subunits have molecular weights of 37 kDa and 23 kDa, but typically run at 40-45 and 20-25 kDa equivalent respectively. Here they ran in fair agreement with the standards at 43 and 23 kDa apparent. Both bands were seen in the CPMV standard lane although the small coat protein line was faint. The small coat protein will contain the product antigen in therapeutic recombinant particles, so it is important that it is not lost. However, it may only be detectable using a more sensitive gel staining method such as silver staining. Virus particles in the host plant are formed from the two subunits in stoichiometric equivalence, therefore the presence of the small coat protein has been inferred from that of the large. Also, the ELISA antibody footprint spans both subunits, confirming the presence of whole particles in the original samples (before SDS treatment). The small coat protein is commonly cut by host plant enzymes, resulting in a band shifted downwards, with the fragments detached during SDS denaturation being too small to retain in the gel. This degraded band was not distinguishable here. Fragmentation of the small coat protein into multiple bands would make it less

distinguishable from the background. The large coat protein was easiest to track through the purification stages.

The L coat protein band was visible against the general background in the homogenate H, stronger against the background of the clarified homogenate C, distinguishable in the ammonium sulphate first cut supernatant A, and again prominent in solid products E1 and Q1 from each type of precipitation. The small coat protein band was similarly seen in fractions H, C, A, B1 and E1. With ammonium sulphate precipitation, a higher background was observed in the product, but this was only 3x diluted in resuspension compared to the PEG product at 18x diluted. PEG precipitated material contained fewer unwanted proteins, the major bands being CPMV and RuBisCO in broadly comparable quantity, a considerable achievement already.

The supernatant produced from 5% PEG precipitation caused severe distortion in the gel in its own lane as well as affecting neighbouring lanes. For this reason it was unclear whether material expected to be in bands below about 50 kDa molecular weight is present or absent.

8.4.2 Recombinant muc14-CPMV

Although this mucin epitope construct was different to that originally tested in gels at Axis (muc1-CPMV), it had an identical size. Results for muc14-CPMV were broadly similar to those obtained for the wild type, reinforcing the applicability of the scale-down process for predicting yields. ELISA and protein assay data allowed a more accurate comparison to be made, but the gel results illustrated many of the same points.

The L coat protein band (unaltered) ran similarly to that of the wild type, again with an apparent molecular weight of 43 kDa, although an unknown faint second band was associated with it. The small coat protein (with mucin epitope insert) had an apparent molecular weight of 29 kDa maximum, and at least two bands were seen in the process samples, although not in the standard (too faint). The muc14-CPMV small coat protein was strongly staining in the homogenate H, (less so in the) clarified homogenate C, clarified solids X1, ammonium sulphate first cut solids B1, and the ammonium sulphate product E1 (at 3x dilution and a volume ratio of 0.22). It is not clear what its fate was in the PEG precipitation product Q1 (9x dilution and a volume ratio of 0.87), partly because of its dilution and partly because of possible distortion from the PEG supernatant lane.

The major protein impurity RuBisCO behaved exactly as for wild type, showing the same partitioning behaviour and clearance. Likewise, the overall levels of nonspecific protein background were similar, taking into consideration the appropriate volume ratios of the sample preparations.

Therefore, the recombinant muc14-CPMV was confirmed to have been purified by both types of precipitation - in accordance with the ELISA and protein assay results. The gel results were valuable in qualitatively indicating the range and distribution of contaminants (and their individual levels where particular proteins can be resolved and identified) but quantitation from gel data was not possible because of the samples' differing volume ratios and the lack of quantitative standards over a range of loading amounts.

In section 11.4 Process Flowsheets, starting from page 145 for wild type and page 147 for muc14-CPMV, is included all the data from which uncorrected CPMV and total protein concentrations and volume ratios were abstracted and dilution factors were calculated. Dilution factors were obtained by dividing the volume ratio of a resuspension by the volume ratio of the solids from which it was made.

9. Summary

“estoppel n. Law the principle which precludes a person from asserting something contrary to what is implied by a previous action or statement of that person or by a previous pertinent judicial determination.” (OED, 1995)

9.1 Assay Development

9.1.1 ELISA

- ◊ the particular microwell plate used bound antibodies more efficiently than another
- ◊ old and new coating antibody showed no difference after months' storage
- ◊ blank readings were noticeable even without coating antibody, due to nonspecific adsorption
- ◊ blocking step was necessary, otherwise slight colour development
- ◊ incubations of 1 h were necessary, 20 min insufficient for standard although blanks the same
- ◊ washing with multipipette was effective and reproducible
- ◊ successive standards stocks, new were 1.1x old by ELISA though indistinguishable by A_{260}
- ◊ standards $>200 \text{ ng ml}^{-1}$ were too strong to give a near-linear response
- ◊ blanks were acceptably low with the cover strip removed for reading
- ◊ 12x detection antibody 10B7 gave 10x OD; standards range was sensitive, blanks were not
- ◊ conjugate antibodies from different sources had different strengths and specificities
- ◊ doubling conjugate concentration used had no effect
- ◊ no effect of SDS as stop reagent; no need for stop reagent if reaction read within 15 min
- ◊ unclarified samples stored at 4°C for up to 25 h gave similar results to fresh preparations

9.1.2 Protein Assay

- ◊ no edge effect, timing effect, or difference between individual- or multipipetting across a plate
- ◊ plant pigments caused no direct interference at the test wavelengths used
- ◊ ammonium sulphate interference was undetectable at 0.1M in standards; at 0.2M and 0.5M colour development was inhibited for 1 h and overnight respectively; therefore only samples under 0.1M (when diluted for assay) were used
- ◊ double wavelength (subtractive) reading gave a narrower standards range, so less accurate

9.2 Initial Extraction

- ◊ frozen leaves crushed in water or buffers for 1 h or overnight yielded 0.6 mg g⁻¹ of CPMV
- ◊ fresh leaves sliced into equivalent size pieces in water yielded only 0.14 mg g⁻¹ of CPMV
- ◊ a range of ten batches homogenised from frozen yielded from 2.2 to 4.8 mg g⁻¹ of CPMV
- ◊ fresh or frozen leaves from the same batch, homogenised, gave the same yield of CPMV
- ◊ fresh leaves from three individual plants of the same batch, homogenised, gave the same yield of CPMV
- ◊ in a disrupted homogenate of frozen leaves in buffer, a steady state of particle size distribution was reached between 15 s and 1 min: after one minute the modal particle size was 7 μm (nominal spherical diameter); with d₉₀ 12 μm, d₅₀ 5 μm, d₁₀ 1 μm
- ◊ the homogenate had maximum viscosity on startup, then was shear-thinning with a constant viscosity of 0.03 Pa s above 200 s⁻¹ shear rate, typical of in-process conditions
- ◊ specific activity (CPMV divided by protein content) ranged from 5-13% in extracts
- ◊ additionally milled leaves yielded 20% more CPMV by concentration (mg ml⁻¹); volume recovery was approximately half, an artifact of scaledown; the CPMV was not recovered on washing through with excess buffer; less than 0.5% glass bead attrition (mass loss) occurred

9.3 Ammonium Sulphate Precipitation

9.3.1 Experimental Variables

- data was given in terms of concentrations (mg ml^{-1}), to illustrate precipitation theory; and yields (mg g^{-1}), to highlight process efficiency
- CPMV and protein partitioning was described by purification factors (PF) and fractionation diagrams
- precipitation from clarified or unclarified homogenate gave little difference in final yields, so unclarified was used
- second cut conditions could not be predicted directly from first cut data because a residual amount of ammonium sulphate (AS) remained in first cut supernatants
- processing cooled or uncooled did not affect overall yields
- milled and homogenised extracts had different starting concentrations of protein but similar CPMV; precipitation appeared to occur at the same AS molarities, for available data

9.3.2 CPMV Product

- from unclarified or low speed centrifuged homogenates, same yields
- salting-in occurred between 0-0.8M AS up to a maximum of 0.81 mg g^{-1} of CPMV
- CPMV precipitated between 0.8-1.5M AS: 0.8M first cut chosen
- 1st cut fractionation diagram predicted for 2nd cut: 95% recovery CPMV, 45% retention protein
- +1.2M AS used at the second cut was equivalent to 1.5M prediction from first cut data, which implied: of 0.8M, 0.3M equivalent remains in solution (e.g. 0.5M actual + a reduced quantity of precipitation-assisting proteins)
- homogenate 5.4 mg g^{-1} ; first cut supernatant 3.4 mg g^{-1} (63%); second cut solids 4.3 mg g^{-1} (80%), giving a first cut net PF of 2.1 and a second cut net PF of 9.7
- rewashing solids recovered 13% of 22% loss in solids at first cut
- second cut loss to supernatant of only 2%
- observed total 136% (basis, 100% in homogenate), may be due to viroplasm disintegration

9.3.3 Protein Contaminant

- little change in supernatant between 0-1.0M AS although some in solids
- salted-in maximum 3.31 mg g^{-1}
- between 1.0-1.2M AS protein began to decline, still decreasing by 2.4M
- milled contained 2 \times in solution, 3-4 \times in solids; this did not affect precipitation behaviour
- observed total 116% (basis, 100% in homogenate)

9.4 PEG Precipitation

9.4.1 Experimental Variables

- precipitation from clarified homogenate gave more virus and less protein in the harvested solids and less virus and more protein in the discarded supernatant, than from unclarified, so clarified was used
- losses in clarification were 60% of protein (basis, 100% in homogenate) and 1/3 of CPMV
- anomalous results were obtained in some runs, where SDS-PAGE confirmed CPMV precipitation, while ELISA measurements indicated incomplete recovery; in most runs, these assays agreed

9.4.2 CPMV Product

- CPMV precipitated from about 3% PEG, less than previously reported
- 92% of CPMV precipitated between 2.5-5% PEG
- CPMV was successfully purified in the pellet, with a PF of 8 from homogenate to pellet, and a reduction in volume of 10× from the leaf
- 92% of CPMV was precipitated from clarified homogenate, overall 61% from the original homogenate, with 20× volume reduction (by comparison, for AS precipitation from unclarified homogenate, 150% of CPMV was recovered between the first and the second cuts; 80% overall, with 25× volume reduction)

9.4.3 Protein Contaminant

- protein precipitated very gradually across the whole range 0-25% PEG, allowing good separation from the CPMV
- with increasing PEG concentration, 140% of the protein present in clarified homogenate was removed; only 18% remained in the product precipitate

9.5 Wild Type & Recombinant

- values for CPMV and protein concentrations throughout processing were similar, wild type to recombinant
- the major contaminant protein RuBisCO was greatly reduced by precipitation with both AS and PEG, shown by SDS-PAGE
- the CPMV L subunit was purified with respect to protein background, shown by SDS-PAGE
- leaf processing yielded 4 mg g⁻¹ of wild type CPMV and 33 mg g⁻¹ protein, or 6 mg g⁻¹ of muc14-CPMV and 37 mg g⁻¹ protein, in homogenate
- PEG precipitation gave 2.8 mg g⁻¹ (70%) of wild type CPMV, with PF of 5 and net PF of 12; 3.6 mg g⁻¹ (60%) of muc14-CPMV, with PF of 3.3 and net PF of 6, better yield for the recombinant but not as good purification because the batch contained more CPMV to start with
- AS precipitation gave 2.7 mg g⁻¹ (68%) of wild type CPMV, with PF of 7 and net PF of 45; 2 mg g⁻¹ (33%) of muc14-CPMV, with PF of 2.5 and net PF of 4, a lower yield for the recombinant, which indicates variation in the processing conditions will be needed to optimise recovery of it

9.6 Process Conclusions

- frozen leaves stored for up to 3 years at -80°C, then completely disrupted by homogenisation in buffer, released more CPMV than previously reported; bead milling was not necessary
- both ammonium sulphate and polyethylene glycol precipitation performed well as process options for early purification from untreated or low-speed centrifuged homogenate: this allows a decision between the two types of precipitant tested to be made on other factors, whether economic or further downstream in processing

10. Future Work

Extraction.....Examine whether yields of CPMV continue to increase with extended storage at -80°C. And, if this is a real effect, whether an alternative disruption technique can be found which achieves the same yields without taking several years! Determine the real baseline levels of CPMV *in planta*.

Purification.....It would be interesting to combine precipitation methods such as isoelectric point precipitation, simple NaCl ionic strength, ammonium sulphate salting out, and PEG polymer with each other, and with heating, in pursuit of either synergies from combined methods, or better yields in differential purification.

Scale up.....Test the process so far on a large scale, using the high speed, continuous-flow tubular-bowl CARR centrifuge for clarification and separation. Study the effect of more heterogeneous mixing, both in the initial disruption chamber of a pilot-scale Silverson during disruption, and subsequently in the precipitation reactor.

Commercial....Edible plant vaccines are likely to be more economically appealing, where they are acceptable on safety grounds, if no processing other than harvest and storage is necessary. A possible extension of the single-antigen, multiple-copy display virus particle (as here) would be multiple-antigen presentation on each particle. If this type of particle is constructible, it would be likely to show even more divergent behaviour during processing stages (such as precipitation) which are highly dependent on surface properties. Therefore, further work on applicable process conditions would be required.

11. Afterwords

11.1 References

“Books are the sources of material for lectures. They should be kept from the young; for to read books and remember what you read, well enough to reproduce it, is called ‘cramming’, and this is destructive of all true education. The best way to protect the young from books is, first, to make sure that they shall be so dry as to offer no temptation; and, second, to store them in such a way that no one can find them without several years’ training.” (Cornford, 1908)

ACDP (Advisory Committee on Dangerous Pathogens). 1995. Laboratory Containment Level 3. In Categorisation of biological agents according to hazard and categories of containment. 4th edition. Sudbury: HSE Books. p.36-40 of 153pp. ISBN 0-7176-1038-1.

Anderson, A. 1999. Friendly fire: Have stray bullets from the “Frankenfood” affair killed off a force for good? Editorial, *New Scientist* 18 Sept:3.

Anon. 2000. Rotating billboard poster, Whitechapel, London EC1, October.

Axis Genetics plc. 1996. Unpublished confidential circular to investors. *Axis Genetics plc: Placing by Hoare Govett*. 93pp.

Axis Genetics plc. 1997. Unpublished publicity brochure. *Axis Genetics plc*. 3 loose pages.

Axis Genetics. 1998. <http://www.axisgenetics.co.uk/Profile.htm> [Corporate Profile] accessed 13/08/98 11:05 GMT.

Bell, D.J.; Hoare, M.; Dunnill, P. 1983. The formation of protein precipitates and their centrifugal recovery. *Advances in Biochemical Engineering* 26:1-72.

Bonner, J.; Varner, J.E. 1976. Plant Biochemistry, 3rd edition. New York: Academic Press.

Bonnerjea, J.; Oh, S.; Hoare, M.; Dunnill, P. 1986. Protein purification: the right step at the right time. *Bio/Technology* 4:954-958.

Bourne, J.R.; Garcia-Rosas, J. 1986. Rotor-stator mixers for rapid micromixing. *Chemical Engineering Research and Design* 64:11-17.

Boychyn, R.M.B. 2000. Scale-down principles for the accelerated design of protein purification processes. Unpublished PhD thesis, University of London.

Brennan, F.R.; Jones, T.D.; Hamilton, W.D.O. 2001. Cowpea mosaic virus as a vaccine carrier of heterologous antigens. *Molecular Biotechnology* 17(1):15-26.

- Brennan, F.R.; Bellaby, T.; Helliwell, S.M.; Jones, T.D.; Kamstrup, S.; Dalsgaard, K.; Flock, J.I.; Hamilton, W.D.O. 1999. Chimeric plant virus particles administered nasally or orally induce systemic and mucosal immune responses in mice. *Journal of Virology* 73:930-938
- Carroll, L. 1893. Sylvie and Bruno Concluded. Reprinted 1999 in The Complete Lewis Carroll vol. 2. Ware: Wordsworth Editions Ltd.
- Cavell, S.; Scopes, R.K. 1976. Isolation and characterisation of the 'photosynthetic' phosphoglycerate kinase from *Beta vulgaris*. *Eur. J. Biochem.* 63:483-490.
- Chapman, S.N.; Wilson, T.M.A. 1997. Plant viruses as pharm-implements. *Chemistry & Industry* 21 July:550-554.
- Chen, Z.; Stauffacher, C.V.; Li, Y.; Schmidt, T.; Bomu, W.; Kamer, G.; Shanks, M.; Lomonosoff, G.; Johnson, J.E. 1989. Protein-RNA interactions in an icosahedral virus at 3.0 Å resolution. *Science* 245:154-159.
- Chustecka, Z. 1997. Axis - putting its future in the power of plants. *Scrip Magazine* May:50-52.
- Coghlan, A. 1999. Caught in the crossfire: Food fight brings down medical research firm. *New Scientist* 18 Sept:22.
- Cornford, F.M. 1908. Microcosmographia Academica: Being a guide for the young academic politician. Cambridge: Bowes&Bowes. 48pp.
- Crook, E.M. 1946. The extraction of nitrogenous materials from green leaves. *Biochemical Journal* 40:197-209.
- Da Poian, A.T.; Johnson, J.E.; Silva, J.L. 1994. Differences in pressure stability of the 3 components of cowpea mosaic virus - implications for virus assembly and disassembly. *Biochemistry* 33:8339-8346.
- Da Poian, A.T.; Oliviera, A.C.; Silva, J.L. 1995. Cold denaturation of an icosahedral virus - the role of entropy in virus assembly. *Biochemistry* 34:2672-2677.
- Dahlman, G.P. 1999. Unpublished response to questioner at Plant Cell Factories conference, 5th May, Central Science Laboratories, York.
- Dalsgaard, K.; Uttenthal, Å.; Jones, T.D.; Xu, F.; Merryweather, A.; Hamilton, W.D.O.; Langeveld, J.P.M.; Boshuizen, R.S.; Kamstrup, S.; Lomonosoff, G.P.; Porta, C.; Vela, C.; Casal, J.I.; Meloen, R.H.; Rodgers, P.B. 1997. Plant-derived vaccine protects target animals against a viral disease. *Nature Biotechnology* 15:248-252.

- de Jager, C.P. 1996. Cowpea mosaic *comovirus*. In Viruses of Plants: Descriptions and Lists from the VIDE Database. Brunt, A.A.; Crabtree, K.; Dallwitz, M.J.; Gibbs, A.J.; Watson, L., eds. Wallingford: CAB International. pp.456-459.
- de Zoeten, G.A.; Assink, A.M.; van Kammen, A. 1974. Association of cowpea mosaic virus-induced double-stranded RNA with a cytopathological structure in infected cells. *Virology* 59:341-355.
- Dixon, M.; Webb, E.C. 1979. Enzymes, 3rd edition. London: Longman.
- Echlin, P. 1992. Low-temperature Microscopy and Analysis. New York: Plenum Publishing Co.
- Ford, B. J. 2000. Free Spirits. *New Scientist* 2258:46-47.
- Foster, P.R. 1994. Protein precipitation. In Engineering Processes for Bioseparations, Weatherley LR, ed. Oxford, Butterworth/Heinemann. pp.73-109.
- Foster, P.R.; Dunnill, P. and Lilly, M.D. 1971. Salting-out of enzymes with ammonium sulphate. *Biotechnology and Bioengineering* 13:713-718.
- Foster, P.R.; Dunnill, P.; Lilly, M.D. 1973. The precipitation of enzymes from cell extracts of *Saccharomyces cerevisiae* by polyethyleneglycol. *Biochimica et Biophysica Acta* 317:505-516.
- Foster, P.R.; Dunnill, P.; Lilly, M.D. 1976. The kinetics of protein salting-out: precipitation of yeast enzymes by ammonium sulphate. *Biotechnology and Bioengineering* 18:545-580.
- Fricker, L. 2000. If Nobel Prizes were decided like presidential elections. In *HMS Beagle: The BioMedNet Magazine* (<http://news.bmn.com/hmsbeagle/91/xcursion/humor>), Issue 91 (Nov. 24).
- Gershenson, J.; Duffy, M.A.; Karp, F.; Croteau, R. 1987. Mechanized techniques for the selective extraction of enzymes from plant epidermal glands. *Analytical Biochemistry* 163:159-164.
- Gosling, W. 2000. We do it - just don't ask how. *The Guardian*, November 30, Science supplement p.3.
- Goydos, J.S.; Elder, E.; Whiteside, T.L.; Finn, O.J.; Lotze, M.T. 1996. A phase I trial of a synthetic mucin peptide vaccine: induction of specific immune reactivity in patients with adenocarcinoma. *Journal of Surgical Research* 63(1):298-304.
- Grant, S.; Patterson, M.; Ledward, D. 2000. Food processing gets freshly squeezed. *Chemistry & Industry* 2:41-80.
- Hebert, T.T. 1963. Precipitation of plant viruses by polyethylene glycol. *Phytopathology* 53:362.

- Hibi, T.; Rezelman, G.; van Kammen, A. 1975. Infection of cowpea mesophyll protoplasts with cowpea mosaic virus. *Virology* 64:308-318.
- HSE (Health & Safety Executive). 1996. A guide to the Genetically Modified Organisms (Contained Use) Regulations 1992, as amended in 1996. Sudbury: HSE Books. 56pp. ISBN 0-7176-1186-8.
- Ingham, K.C. 1990. Precipitation of proteins with polyethylene glycol. *Methods in Enzymology* 182:301-306.
- Jervis, L.; Pierpoint, W.S. 1989. Purification technologies for plant proteins. *Journal of Biotechnology* 11:161-198.
- Juckes, I.R.M. 1971. Fractionation of proteins and viruses with polyethylene glycol. *Biochimica et Biophysica Acta* 229:535-546.
- Keshavarz-Moore, E. 1996. Cell disruption: a practical approach. In Downstream Processing of Natural Products, Verrall, M.S., ed. Chichester: John Wiley & Sons Ltd. pp.41-52.
- Klootwijk, J.; Klein, I.; Zabel, P.; van Kammen, A. 1977. Cowpea mosaic virus RNAs have neither m⁷GpppN...nor mono-, di-, or triphosphates at their 5' ends. *Cell* 11:73.
- Knorr, D.; Angersbach, A. 1998. Impact of high-intensity electric field pulses on plant membrane permeabilization. *Trends in Food Science and Technology* 9:185-191.
- Levy, M.S.; Collins, I.J.; Yim, S.S.; Ward, J.M.; Titchener-Hooker, N.; Ayazi Shamlou, P.; Dunnill, P. 1999. Effect of shear on plasmid DNA in solution. *Bioprocess Engineering* 20(1):7-13.
- Limon-Lason, J.; Hoare, M.; Orsborn, C.B.; Doyle, D.J.; Dunnill, P. 1979. Reactor properties of a high-speed bead mill for microbial cell rupture. *Biotechnology and Bioengineering* 21:745-774.
- Lin, T.; Porta, C.; Lomonosoff, G.P.; Johnson, J.E. 1996. Structure-based design of peptide presentation on a viral surface: the crystal structure of a plant/animal virus chimera at 2.8Å resolution. *Folding Design* 1:179-181.
- Lomonosoff, G.P.; Johnson, J.E. 1991. The synthesis and structure of comovirus capsids. *Progress in Biophys. Molecular Biology* 55:107-137.
- Lomonosoff, G.P.; Shanks, M. 1999. Comoviruses (Comoviridae). In Encyclopedia of Virology, 2nd edition. Granoff, A.; Webster, R.G., eds. San Diego: Academic Press. Vol.1 pp.285-291.

-
- Lowry, O.H.; Rosebrough, N.J.; Farr, A.L.; Randall, R.J. 1951. Protein measurement with the Folin phenol reagent. *Journal of Biological Chemistry* 193:265-275.
- Lugg, J.W.H. 1939. XIII. The representativeness of extracted samples and the efficiency of extraction of protein from the fresh leaves of plants; and some partial analyses of the whole proteins of leaves. *Biochemical Journal* 33:110-122.
- Mahadevan, H.; Hall, C.K. 1990. Statistical-mechanical model of protein precipitation by nonionic polymer. *AIChE Journal* 36:1517-1528.
- Mahadevan, H.; Hall, C.K. 1992. Theory of precipitation of protein mixtures by nonionic polymer. *AIChE Journal* 38:573-591.
- Matthews, R.E.F. 1991. Plant Virology, 3rd edition. San Diego: Academic Press.
- Minocha, R.; Shortle, W.C. 1993. Fast, safe, and reliable methods for extraction of major inorganic cations from small quantities of woody plant-tissues. *Canadian Journal of Forest Research* 23:1645-1654.
- Minocha, R.; Shortle, W.C.; Long, S.L.; Minocha, S.C. 1994. A rapid and reliable procedure for extraction of cellular polyamines and inorganic-ions from plant-tissues. *Journal of Plant Growth Regulation* 13:187-193.
- Newman, J.H. 1865. Demons in Dream of Gerontius, poem by Cardinal Newman set to music by Elgar in 1899.
- Nichols, M.E.K.; Stanislaus, T.; Keshavarz-Moore, E.; Young, H.A. 2001. Disruption of leaves and initial extraction of wildtype CPMV virus as a basis for producing vaccines from plants. *Journal of Biotechnology* [note added in press: available online November 2001 but did not appear as print edition until 18 January 2002] 92(3):229-235.
- Nichols, M.E.K.; Stanislaus, T.; Keshavarz-Moore, E.; Young, H.A. Recombinant plant virus vaccines: clarification and initial purification by ammonium sulphate precipitation. *Enzyme and Microbial Technology*, in preparation.
- Nichols, M.E.K.; Stanislaus, T.; Keshavarz-Moore, E.; Young, H.A. Towards plant virus vaccines: clarification and initial purification by polyethylene glycol precipitation. *Biotechnology Progress*, in preparation.
- OED. 1995. Estoppel. The Oxford English Reference Dictionary. Pearsall, J.; Trumble, B., eds. Oxford: Oxford University Press. p.480.

- Peterson, G.L. 1979. Review of the Folin phenol protein quantitation method of Lowry, Rosebrough, Farr and Randall. *Analytical Biochemistry* 100:201-220.
- Pinker, S. 1994. The Language Instinct. London: Allen Lane, The Penguin Press. p.399.
- Pirie, N.W. 1971a. Drying, Preservation, Solvent Extraction and Separation into 'Chloroplast' and 'Cytoplasmic' Fractions. In Leaf Protein: its agronomy, preparation, quality and use. Pirie, N.W., ed. Oxford: Blackwell Scientific Publications. p.86-91. 196pp.
- Pirie, N.W. 1971b. Presentation of Leaf Protein on the Table. In Leaf Protein: its agronomy, preparation, quality and use. Pirie, N.W., ed. Oxford: Blackwell Scientific Publications. pp.156-157.
- Polson, A. 1993. Isolation of viruses by electro-extraction of infected plants. *Preparative Biochemistry* 23:51-57.
- Polson, A.; Potgeiter, G.M.; Largier, J.F.; Mears, G.E.F.; Joubert, F.J. 1964. The fractionation of protein mixtures by linear polymers of high molecular weight. *Biochimica et Biophysica Acta* 82:463-475.
- Polson, A.; van der Merwe, K.T. 1993. Electro-extraction of viruses from infected-plant tissue applied to turnip yellow mosaic, tobacco mosaic and maize streak viruses. *Preparative Biochemistry* 23:255-265.
- Porta, C.; Spall, V.E.; Loveland, J.; Johnson, J.E.; Barker, P.J.; Lomonossoff, G.P. 1994. Development of cowpea mosaic-virus as a high-yielding system for the presentation of foreign peptides. *Virology* 202:949-955.
- Porta, C.; Wang, G. J.; Cheng, H.; Chen, Z. G.; Baker, T. S.; Johnson, J. E. 1994. Direct imaging of interactions between an icosahedral virus and conjugate F_{ab} fragments by cryoelectron microscopy and X-ray crystallography. *Virology* 202:949-955.
- Postgate, J. 2000. Microbes and Man, 4th ed. Cambridge: Cambridge University Press. p.113.
- Pratchett, T.; Stewart, I.; Cohen, J. 2000. The Science of Discworld. London: Ebury Press.
- Richardson, P.; Hoare, M.; Dunnill P. 1989. Optimization of fractional precipitation for protein purification. *Chemical Engineering Research and Design* 67:273-277.
- Richardson, P.; Hoare, M.; Dunnill, P. 1990. A new biochemical engineering approach to the fractional precipitation of proteins. *Biotechnology and Bioengineering* 36:354-366.

- Ritter, R.M. 2000. LP. In The Oxford English Dictionary for Writers and Editors, 2nd edition. Oxford: Oxford University Press. p.203.
- Sambrook, J.; Fritsch, E.F.; Maniatis, T. Molecular cloning: a laboratory manual, 2nd edition. 1989. New York: Cold Spring Harbor Laboratory Press. Vol. 3, pp.18.47-18.55.
- Santa Cruz, S.; Chapman, S.; Roberts, A.G.; Roberts, I.M.; Prior, D.A.M.; Oparka, K.J. 1996. Assembly and movement of a plant virus carrying a green fluorescent protein overcoat. *Proceedings of the National Academy of Sciences of the United States of America* 93(13):6286-6290.
- Schmidt, T.; Johnson, J.E.; Phillips, W.E. 1983. The spherically averaged structures of cowpea mosaic virus components by X-ray solution scattering. *Virology* 127:65-73.
- Scopes, R.K. 1987. Protein Purification: Principles and Practice, 2nd edition. New York: Springer-Verlag.
- Shermer, M. 2001. Nano Nonsense and Cryonics. *Scientific American* 285(3):23.
- Stace-Smith, R. 1981. Comoviruses. In Handbook of Plant Virus Infections and Comparative Diagnosis. Kurstak, E., ed. Elsevier/North-Holland Biomedical Press. ISBN 0-444-80309-2. Chapter 8 p.171- .
- Strauss, S. 1995. The Sizesaurus. New York: Kodansha International.
- Taylor, K.M.; Porta, C.; Lin, T.W.; Johnson, J.E.; Barker, P.J.; Lomonosoff, G.P. 1999. Position-dependent processing of peptides presented on the surface of cowpea mosaic virus. *Biological Chemistry* 380:387-392.
- Tsoka, S.; Ciniawskyj, O.C.; Thomas, O.R.T.; Titchener-Hooker, N.J.; Hoare, M. 2000. Selective flocculation and precipitation for the improvement of virus-like particle recovery from yeast homogenate. *Biotechnology Progress* 16:661-667.
- Usha, R.; Rohll, J.B.; Spall, V.E.; Shanks, M.; Maule, A.J.; Johnson, J.E.; Lomonosoff, G.P. 1993. Expression of an animal virus antigenic site on the surface of a plant virus particle. *Virology* 197:366-374.
- van Kammen, A. 1967. Purification and properties of the components of cowpea mosaic virus. *Virology* 31:633-642.

van Kammen, A.; de Jager, C.P. 1978. Cowpea Mosaic Virus. CMI/AAB Descriptions of Plant Viruses No. 197 (No. 47 revised). Commonwealth Agricultural Bureaux. Kew: Commonwealth Mycological Institute.

Vega-Mercado, H.; Martin-Belloso, O.; Qin, B.L.; Chang, F.J.; Gongora-Nieto, M.M.; Barbosa-Cánovas, G.V.; Swanson, B.G. 1997. Non-thermal food preservation: pulsed electric fields. *Trends in Food Science and Technology* 8:151-157.

Walkey, D.G.A. 1991. Applied Plant Virology, 2nd edition. London: Chapman and Hall.

11.2 Acronyms & Abbreviations

"LP large paper, long-playing record, Lord Provost, low pressure, (paper) large post" (Ritter, 2000)

10B7	a monoclonal antibody to CPMV
Å	Ångstrom, 1 Å = 0.1 nm
ABTS	2,2'-azino-bis(3-ethylbenzthiazoline-6-sulfonic acid)
AEX	anion exchange chromatography
API	active pharmaceutical ingredient
AS	ammonium sulphate
A _x	light absorbance at x nm
B	bottom (density fraction)
BBSRC	Biotechnological and Biological Sciences Research Council
BCG	bacillus Calmette-Guerin
BSA	bovine serum albumin
c.	<i>circa</i>
CEO	Chief Executive Officer
CH	Switzerland
CIP	clean-in-place
CPMV	cowpea mosaic <i>comovirus</i>
cv.	cultivar
CVP	chimeric virus particle
d	day(s)
DAS	double antibody sandwich
DEP	dilution endpoint
DNA	deoxyribonucleic acid
DPI	days post-infection
DTI	Department of Trade and Industry
DW	dry weight
d _x	size which x% of the particles present are smaller than
ELISA	enzyme-linked immunosorbent assay
EPV	edible plant virus vaccine
FMDV	foot-and-mouth disease virus
FW	fresh (or frozen, undried) weight

<i>g</i>	acceleration due to gravity, 9.81 m s ⁻²
GMM	genetically modified microorganism
gp41	an HIV coat protein
h	hour(s)
HEPA	high efficiency particulate absorption
HIC	hydrophobic interaction chromatography
HIV	human immunodeficiency virus
HRV	human rhinovirus
HSE	Health and Safety Executive
ID	internal diameter
IEP	isoelectric point pH
IMS	industrial methylated spirit
kDa	kilo-Daltons, units of molecular mass
L	large CPMV coat protein
L	litre, 1 L = 10 ⁻³ m ³
L.	species discovered by Linnaeus
L123	a polyclonal antibody to CPMV
LINK	collaborative industry-academia DTI research programmes
M	middle (density fraction)
M	molarity, moles L ⁻¹
MAFF	Ministry of Agriculture, Fisheries and Food
mast	mastitis epitope insertion
MES	methyl ether sulphone
MEV	mink enteritis <i>parvovirus</i>
min	minute(s)
M _r	(relative) molecular mass
muc	mucin epitope, mucin epitope insertion
MW	(relative) molecular mass
N	ionic strength, ions L ⁻¹
NI	National Insurance
OD	optical density
PBST	phosphate buffered saline with Tween
PEG	polyethylene glycol
PES	polyethersulphone

PF	purification factor
pI	isoelectric point pH
PVX	potato virus X <i>potexvirus</i>
r ²	least squares measure of goodness of fit of a curve
RA	research assistant
RCF	relative centrifugal force
RH	relative humidity
RMM	(relative) molecular mass
RNA	ribonucleic acid
RO	reverse osmosis-purified
rpm	revolutions per min
RuBisCO	ribulose-1,3-bisphosphate carboxylase
S	small CPMV coat protein
S1	most concentrated CPMV standard
S _{20-C, water}	Svedberg unit of sedimentation
SDS	sodium dodecyl sulphate
SDS-PAGE	sodium dodecyl sulphate polyacrylamide gel electrophoresis
SEM	scanning electron microscopy
SOP	standard operating procedure
SPINDIGO	Sustainable Production of Indigo from Plants
ssRNA	single stranded ribonucleic acid
T	top (density fraction)
TEM	transmission electron microscopy
TEMED	N,N,N',N'-tetramethylethylenediamine
TMV	tobacco mosaic <i>tobamovirus</i>
Tris	Tris(hydroxymethyl)aminomethane
UCL	University College London
UK	United Kingdom
UV	ultraviolet light
v/v	volumetric ratio, no units
VLP	virus-like particle
w/w	weight per weight
WT	wild type

11.3 Example SOPs

11.3.1 ELISA

SOP 9.2: Enzyme Linked Immuno Sorbent Assay - ELISA (TWO plates)

1. Equipment

96 well Flat bottom, Immulon 4HBX plates
Pipettes (20-200 μ l 8-channel, 5-40 μ l, 40-200 μ l, 1ml and 5ml)
37°C orbital-shaking incubator
Plate reader
Plate sealers
Eppendorf tube shaker (IKA-VIBRAX-VXR)
50ml Falcon tubes

2. Reagents

Primary antibody: L123 sheep anti CPMV antibody (supplied by Axis Genetics)
Secondary antibody: 10B7 monoclonal mouse anti CPMV antibody (supplied by Axis Genetics)
Conjugate antibody: Rabbit anti mouse immunoglobulin conjugated to Horseradish Peroxidase (DAKO)
Marvel dried skimmed milk powder
10mg ABTS tablets
30% (w/w) Hydrogen peroxide
Stock CPMV (conc. 2.2mg/ml, prep. on 8/12/98 from 8.3mg/ml spiking stock)

3. Buffers

200mM sodium carbonate buffer, pH 9.6 (1 in 4 dilution gives 50mM buffer)
1 X PBST (0.05% Tween in phosphate buffered saline)
50mM citric acid, pH 4.0

4. Method

4.1. Coating the plate (the day before) [1 in 10,200 dilution]

- Pipette 10ml of 200mM sodium carbonate buffer and 30ml of RO water in to a falcon tube.
- Mix the solution on a vortex mixer for 1 minute and check the pH of the 50mM sodium carbonate solution is 9.6 (range 9.4 - 9.8).
- Prepare **A** and **B** as follows;
A \Rightarrow 5 μ l of L123 sheep anti CPMV antibody to 995 μ l 50mM sodium carbonate in a 2.2ml eppendorf tube and mix on a shaker at 1800rpm for 1 minute.
B \Rightarrow 600 μ l of **A** to 30ml of 50mM sodium carbonate in a falcon tube and mix on a vortex mixer for 1 minute.
- Add 100 μ l of **B** to each well of the plate. Seal the plate with plate sealer, label and store at 4°C overnight.

4.2. Blocking the plate

- Prepare a 10% milk solution as follows;
Add 4g of marvel in to a falcon tube and add 40ml of 1 X PBST.
Mix the solution on a vortex mixer for 1 minute.
- Remove the plate sealer, add 100 μ l of 10% milk solution to each well and incubate at 37°C for at least 1 hour with shaking at 100rpm.

4.3. Preparation of standards and controls

- Prepare **E** as follows;

5 μ l of the stock 2.2mg/ml CPMV to 1995 μ l of 1 X PBST in a 2.2ml eppendorf tube and mix the solution on a shaker at 1800rpm for 1 minute.

- Prepare standards and controls as follows;

Standards/Controls	Concentration, ng/ml	Vol. of E added, μ l	Vol. of 1 X PBST added, ml
S1	185.99	35	1.0
S2	160.19	30	1.0
S3	134.15	25	1.0
S4	107.84	20	1.0
S5	81.28	15	1.0
S6	54.46	10	1.0
S7	27.36	5	1.0
H	185.99	35	1.0
M	107.84	20	1.0
L	54.46	10	1.0

- Prepare the standards and controls in 2.2ml eppendorf tubes, mix on a shaker at 1800rpm for at least 1 minute.

4.4. Preparation of samples

- Choose the required dilution of the samples, prepare them in eppendorf tubes with 1 X PBST.
- Mix the tubes on a shaker at 1800rpm for at least 1 minute.

4.5. Application of standards, controls and samples

- Remove the plate from the incubator, empty the plate by flicking the contents into Virkon 1% solution. Blot the plate dry.
- Wash the plate 4 times as follows;

Pipette 200 μ l of 1 X PBST into each well using an 8 channel pipette, then flick out the well contents and repeat a further twice. Blot the plate dry.

- Add 100 μ l of the standards, controls and samples according to the template.
- Cover the plate with the same plate sealer and incubate at 37°C for 1 hour with shaking at 100rpm.

4.6 Preparation and application of secondary antibody, 10B7 [1 in 2001 dilution]

- Prepare **C** as follows;

C \Rightarrow 15 μ l of 10B7 to 30ml of 1 X PBST in a falcon tube and mix on a vortex mixer for 1 minute.

- Add 100 μ l of **C** to each well of the plate. Seal the plate with the same plate sealer and incubate at 37°C for 1 hour with shaking at 100rpm.

4.7. Preparation and application of Conjugate antibody [1 in 1001 dilution]

- Prepare **F** and as follows;

Pipette 30ml of 1 X PBST in a falcon tube and add 30 μ l of conjugate to the tube.

Mix the solution on a vortex mixer for 1 minute.

- Remove the plate from the incubator, empty the plate by flicking the contents into Virkon 1% solution. Blot the plate dry.
- Wash the plate 3 times as follows;

Pipette 200 μ l of 1 X PBST into each well using an 8 channel pipette, then flick out the well contents and repeat a further twice. Blot the plate dry.

- Add 100 μ l of the conjugate **F** to each well. Seal the plate with the same plate sealer and incubate at 37°C for 1 hour with shaking at 100rpm.

4.8. Preparation and application of the substrate

- Prepare solution **G** as follows;

G \Rightarrow Add one 10mg tablet of ABTS to 50ml of 50mM citric acid. Mix on a stirrer until dissolved.

- Remove the plate from the incubator, empty the plate by flicking the contents into Virkon 1% solution. Blot the plate dry.

-
- Wash the plate 3 times as follows;
Pipette 200 μ l of 1 X PBST into each well using an 8 channel pipette, then flick out the well contents and repeat a further twice. Blot the plate dry.
 - Prepare solution **H** as follows; (**PLATE 1**)
H \Rightarrow Pipette 15ml of the substrate solution **G** in a falcon tube.
Add 30 μ l of 30% Hydrogen peroxide solution to the tube and mix it on a vortex mixer for at least 1 minute.
 - Add 100 μ l of solution **H** to each well of the first plate. Seal the plate with the same plate sealer and incubate at 37°C with shaking at 100rpm.
 - After 5 minutes prepare solution **H** as follows; (**PLATE 2**)
H \Rightarrow Pipette 15ml of the substrate solution **G** in a falcon tube. Add 30 μ l of 30% Hydrogen peroxide solution to the tube and mix it on a vortex mixer for at least 1 minute.
 - Add 100 μ l of solution **H** to each well of the second plate. Seal the plate with the same plate sealer and incubate at 37°C with shaking at 100rpm.
 - Using the plate reader, read each plate at 405nm after EXACTLY 15 minutes.

11.3.2 Protein Assay

SOP 10.2: Protein assay - TWO PLATES

1. Equipment

96 well Sarstedt plate
 Pipettes (20-200 μ l 8-channel, 5-40 μ l and 40-200 μ l)
 37 $^{\circ}$ C orbital-shaking incubator
 Plate reader
 Plate sealers
 Eppendorf tube shaker (IKA-VIBRAX-VXR)

2. Reagents

10mM phosphate buffer, pH 7.0
 BioRad 'DC' Protein assay kit reagents A and B
 BSA standard, pre-diluted to 400 μ g/ml and stored at -80 $^{\circ}$ C in 250 μ l aliquots
 Controls, pre-prepared and stored at -80 $^{\circ}$ C in 100 μ l aliquots;

H	=	180 μ g/ml
M	=	100 μ g/ml
L	=	40 μ g/ml

3. Method

3.1. Preparation of standards

- Thaw two 250 μ l single-use aliquot of the 400 μ g/ml BSA stock and two tubes of each of the previously prepared controls H, M, L, vortex gently to recombine and then spin for a couple of seconds to bring down to the bottom of the tube.
- Prepare standards as follows;

Standards	Concentration μ g/ml	vol. of BSA added μ l	vol. of 10mM phosphate added, μ l
S1	20	10	190
S2	50	25	175
S3	80	40	160
S4	120	60	140
S5	160	80	120
S6	200	100	100

- Prepare the standards in 2.2ml eppendorf tubes, mix on the shaker at 1800rpm for 1 minute.

3.2. Preparation of samples

- Choose the required dilution of the samples, prepare them in eppendorf tubes with 10mM phosphate buffer.
- Mix the tubes on the shaker at 1800rpm for 1 minute.

3.3. Assay procedure

- Using the multichannel pipette, add 20 μ l of *reagent A* to all wells.
- Add 40 μ l of the standard, control and samples in the format above.
- Using the multichannel pipette, add 160 μ l of *reagent B* to all wells and cover the plate with the plate sealer. Immediately start the timer, then proceed to incubation without delay.
- Place securely in the incubator at 37 $^{\circ}$ C and 100rpm.
- Remove the plate from the incubator after 15 minutes. Remove the sealing strip and read the plate at 750nm in the plate reader.

11.3.3 SDS-PAGE

SOP 11: SDS-PAGE (Sodium Dodecyl Sulfate-Polyacrylamide Gel Electrophoresis): 2 x mini gels

1 Equipment

Two sets of glass plates; one notched and one with flat ridges
Tripod, burner, narrow glass beaker, tube holder
One vertical gel electrophoresis tank
2.2ml screw cap eppendorf tubes
Pipettes (20 μ l, 200 μ l and 5ml)
Sample loading pipette tips
Two 12-well gel combs
Eppendorf tube shaker
Two opaque gaskets
Four casting clamps
Disk to save the gel
Syringe needle
Power pack

2 Reagents: Make sure all reagents are at room temperature

(30:0.8)% Acrylamide-bisacrylamide (ultra pure protogel)
CPMV Gel standard (2.5 μ g/10 μ l: i.e. 2.0 μ g/well)
Ammonium persulphate (freshly prepared)
3M Tris-HCl Main gel buffer, pH 8.8
0.5M Tris-HCl Stacking gel buffer
10 x Running buffer, pH 8.3
Marker (stored at -80°C)
 β -mercaptoethanol
Coomassie blue R
Loading buffer
20% Glycerol
10% SDS
RO water
De-stain
TEMED
IMS

3 Method

3.1 Apparatus set up

- Wear gloves, rinse hands with RO water. Place the two glass plates (one is flat and the other one is notched with integral glass spacers) on blue roll.
- Clean the plates and the combs with IMS and dry with tissue. Place both plates on blue roll.
- Lay the gasket around the sides and bottom edge of the spacer making sure no gap is formed between the spacers and the gasket.

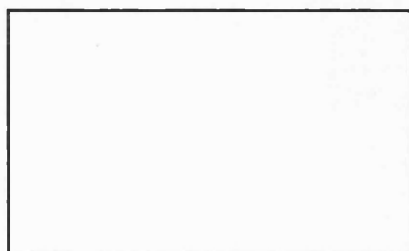

FLAT PLATE

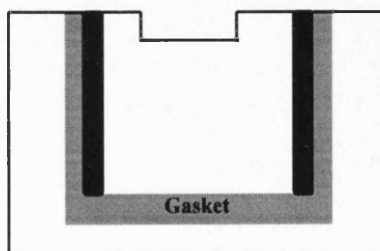

NOTCHED
PLATE

- Take the flat plate and place it on top of the other plate making sure that the edges are aligned. Clip on two clamps, magnetic sides facing in opposite directions, and align bottom edges of the plates and the clamps so that the assembly stands upright.

3.2 Preparation of Main gel

The procedure is for the production of 12.5% main gel. The volume prepared is enough to pour two mini gels.

- Prepare 10% Ammonium persulphate as follows;
Weigh out 0.10g of Ammonium persulphate in a 7ml bijoux tube and pipette 1.0ml RO water into the tube (if more than 0.10g is measured, note quantity and add RO water as appropriate to make 10%). Shake to mix.

RO water	7.1ml	(5ml + 1.05ml x 2)
Acrylamide-bisacrylamide	6.25ml	(5ml + 1.05ml + 200µl)
3M Tris-HCl Main gel buffer	1.9ml	(0.95ml x 2)
10% SDS	150µl	
10% Ammonium persulphate	225µl	(using 1ml pipette)
TEMED	15µl	

- Label a plastic universal bottle, main gel, and pipette the above reagents in order into it. Do not add the ammonium persulphate and TEMED, polymerising agents, until ready to pour.
- Immediately invert the bottle 2 or 3 times to mix and quickly pour into the gap of the two plates up to the first mark or just below the first mark without causing air bubbles. Keep the left over solution to check whether the gel is set.
- Quickly run some RO water gently from a squeeze bottle to overlay the gel as it sets. This levels the top, excludes oxygen, and rinses away unpolymerised acrylamide.

3.3 Preparation of Stacking gel

When the main gel is set (at least 15 minutes), carefully pour off the RO water overlaying the main gel. Use the corner of a tissue to blot any remaining large drops.

RO water	6.1ml	(5ml + 1.1ml)
Acrylamide-bisacrylamide	1.25ml	(1.05ml + 200µl)
0.5M Tris-HCl Stacking gel buffer	2.5ml	(1.0ml x 2 + 0.5ml)
10% SDS	100µl	
10% Ammonium persulphate	150µl	
TEMED	15µl	

- Label a plastic universal bottle, stacking gel, and pipette the above reagents in order into it. Do not add the ammonium persulphate and TEMED, polymerising agents, until ready to pour.
- Invert the bottle 2 or 3 times and quickly pour into the gap of the two plates until it slightly overflow.
- Immediately push the comb, pushing air bubbles away.
- Leave the stacking gel to set. Check the left over solution as an indicator (sets within 30min.).

3.4 Preparation of Loading buffer (carry out in a fume cupboard)

- Pipette 0.5ml of Loading buffer into a 2.2ml eppendorf tube and add 25µl of β-mercaptoethanol into the same tube and mix it well.

3.5 Preparation of samples, CPMV standard and marker for loading

- Pipette 20µl of samples and CPMV standard into separate screw cap tubes and add 20µl of Loading buffer into each tube.
- Fill a narrow glass beaker with water so that it covers the sample holder. Heat to boil and place the sample holder with samples, CPMV standard and the marker into the beaker.
- Boil it for 3minutes, remove and centrifuge at 13,000rpm for 2 minutes.

3.6 Running the gel

3.6.1 Preparation of 1 x Running buffer

Measure 60ml of 10 x Running buffer in a 1L measuring cylinder and fill up to 600ml with RO water.

- Have the gel assembly standing upright. Carefully remove the comb, clamps and the gasket.
- Slide the gel-plates into the tank, notched plates facing middle of the tank. **NB:** if only one gel is being run, clamp a double thickness blank glass plate against one side.

- Pour some running buffer into the bottom reservoir avoiding air bubbles to cover the bottom gel. Fill the top chamber of the tank with the running buffer **ensuring that the gel is fully covered**. Keep some running buffer to recover the gels. Using a needle, washout the wells with running buffer taken from the top chamber.

TEMPLATE

1	2	3	4	5	6	7	8	9	10	11	12
M	C	S	S	S	S	S	S	S	S	S	M

M MARKER

C CPMV STANDARD (2 μ g/well)

S SAMPLES

Marker

1KDa = 1000Da (Dalton)

Phosphorylase b = 94KDa

BSA (Bovine Serum Albumin) = 67.1KDa

Ovalbumin = 43KDa

Carbonic anhydrase = 30KDa

Soybean trypsin inhibitor = 20.1KDa

α -lactalbumin = 14.4KDa

- Using the long pipette tips, load 10 μ l of marker, CPMV standard and each sample into the wells from left to right according to the template. Load 10 μ l of loading buffer into unused wells.
- **NB:** If samples are loaded on two gels, first load on the gel which faces you and make a mark on the glass of the tank if possible to identify as GEL1. Turn the gel tank at 180 $^{\circ}$ so that the second gel faces you. Now load the second gel: GEL2.
- Connect the tank to the power pack, matching red to red and black to black terminals. Turn the power supply on. Press SET and adjust voltage to 64V and current to 30mA using \pm buttons. Press RUN and check that the gel is running, i.e. look for the air bubbles rising from the bottom.
- Run the gel for approximately 30 minutes, i.e. until the dye forms a neat line between the stacking gel and main gel. Then re-set the voltage to 120V and current to 50mA. Run the gel for approximately 1 to 1 $\frac{1}{2}$ hours until the dye reaches the bottom of the gel plates (i.e. orange band at the bottom of the plates).
- Press SET then turn the power pack off. Remove the gel plates from the tank, identifying gel plate 1 and 2 carefully.

3.7 Coomassie blue staining

- Pour some running buffer into a plastic box and remove the gel plates. Using a metal spatula remove the flat plate so that the gel is stuck on the notched plate (it is convenient to leave the gel on the notched plates as we can use the template as it stands; remember the notched plate faces the middle of the tank).
- Take the notched plate with the gel and using a sharp knife cut the gel along the line where stack gel ends. Cut a small piece at the bottom of the left hand side (LHS) corner of the main gel.
- Place the notched plate into running buffer in the box gently so that the gel will drop into the buffer.
- Repeat the above two procedures with GEL2; this time cut the corner of the top of the main gel.
- Drain the running buffer and add coomassie blue to cover the gels, close with a lid and leave it on the micro-shaker at 50rpm over-night.

3.8 De-stain

- Carefully drain out the coomassie blue through a funnel lined with filter paper in its bottle. Pour de-stain into the box to cover the gel; place a piece of sponge and leave it on the micro-shaker for approximately 30 minutes.
- Discard the de-stain down the sink, squeeze the sponge and pour some more de-stain into the box. Leave it on the shaker for approximately 1 to 1 $\frac{1}{2}$ hours.
- Drain the de-stain, pour fresh de-stain and leave it on the shaker for another 1 to 1 $\frac{1}{2}$ hours. Discard the de-stain and check that the gel is almost completely free of blue dye.
- Cover the gel with 20% glycerol.

3.9 Cleaning the gel tank

- Drain the running buffer in the tank down the sink. Wash it with warm water. Wash the gaskets in water.
- Fill a plastic box with warm water, pour some detergent and leave the gel plates, combs in water to soak. Wash in warm water, rinse with RO water and place them on blue roll to drain.

3.10 Taking photo of the gel (three gels can be stored on one disk)

- Wear lab coat and gloves.
- Switch on Disk Drive, Monitor, Printer, Lens and Trans-illuminator plugs on the wall. Switch on UVP, Power Sony, Printer, Trans-illuminator ('WHITE' position) on the machines. Check that the 'IMAGE STORE 5000' disk is in UVP.
- Check that the camera is on left hand side (if not, unscrew the button at the back of the camera, lift it up the slot, move across to the other side, slip it in the slot and screw it on. Close the other hole with the lid provided).
- Open the lid of the illuminator, clean the surface with 20% glycerol and blue roll. Wet the surface thoroughly. Place gel 1 on the surface gently as follows;

Using the arrow keys on the keyboard, highlight GRAB. Using the adjustments (three of them) on the camera focus the field so that we can see the grid lines on the screen. Move the gel gently so that it is in between the middle grid lines.

Close the lid and ENTER.

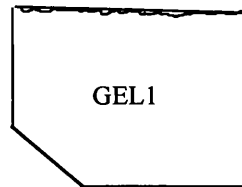

- Using the arrow keys, highlight LUTS and ENTER. This will take to CONTRAST and ENTER. Now using the arrow keys adjust the image of the gel and press ENTER.
- Using the arrow keys highlight BRIGHT and ENTER. Again using the arrow keys adjust the brightness of the gel and using arrow key press OK. With the arrow keys highlight PRINT and press ENTER.
- Remove the 'IMAGE STORE 5000' disk and insert our disk. Using the arrow keys highlight SAVE and press ENTER. When its asked to be formatted, press OK (gel 1 will be saved under the name of 'image1'). When the image1 is saved, the monitor will prompt.
- Open the lid of the illuminator, remove the gel carefully and place it in the plastic box. Place gel 2 on the surface gently as follows;

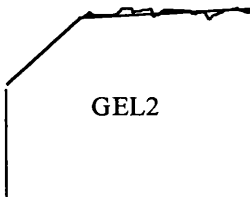

Repeat the above steps. Gel 2 will be saved under the name of 'image 2'.

- Take out our disk and insert the 'IMAGE STORE 5000' disk. Open the lid of the illuminator, remove the gel carefully and place it in the plastic box. Clean the surface with blue roll and close the lid. Switch off everything.

11.4 Process Flowsheets

11.4.1 Wild Type CPMV

Figure 45. Wild type CPMV process flowsheet.

Key to process stream labels:

L	cowpea leaf feedstock
T1-T5	Tris-HCl buffer addition
PE1	PEG precipitant addition
AS1-AS2	ammonium sulphate precipitant addition
H	untreated homogenate
H1-H2	homogenate for alternative purifications
C	clarified homogenate
C1	clarified homogenate taken forwards
X	solids discard from clarification
X1	resuspended solids from clarification
PM	PEG precipitation mixture
AM1-AM2	ammonium sulphate precipitation mixture
P	supernatant from PEG precipitation
Q	solids product from PEG precipitation
Q1	resuspended solids from PEG precipitation
A	supernatant from first cut ammonium sulphate precipitation
A1	supernatant from first cut ammonium sulphate precipitation taken forwards
B	solids discard from first cut ammonium sulphate precipitation
B1	resuspended solids from first cut ammonium sulphate precipitation
D	supernatant from second cut ammonium sulphate precipitation
E	solids product from second cut ammonium sulphate precipitation
E1	resuspended solids from second cut ammonium sulphate precipitation

Key to derived quantity abbreviations:

process vol	process volume, ml
vol ratio	volume ratio with respect to 1 for homogenate, no units
CPMV conc unc	CPMV concentration uncorrected in sample, mg ml ⁻¹
CPMV conc clar	CPMV concentration corrected to the original volume of clarified homogenate starting material, mg ml ⁻¹
CPMV conc hom	CPMV concentration corrected to the original volume of homogenate, mg ml ⁻¹
CPMV yield	CPMV yield, mg per g leaf
protein conc unc	protein concentration uncorrected in sample, mg ml ⁻¹
protein conc clar	protein concentration corrected to the original volume of clarified homogenate starting material, mg ml ⁻¹
protein conc hom	protein concentration corrected to the original volume of homogenate, mg ml ⁻¹
protein yield	CPMV yield, mg per g leaf
purity	relative amount of CPMV compared to protein, no units
purity net	relative amount of CPMV compared to non-CPMV protein, no units
PF	stage purity compared to homogenate purity, no units
PF net	stage purity net compared to homogenate purity net, no units

Figure 45. Wild type CPMV process flowsheet.

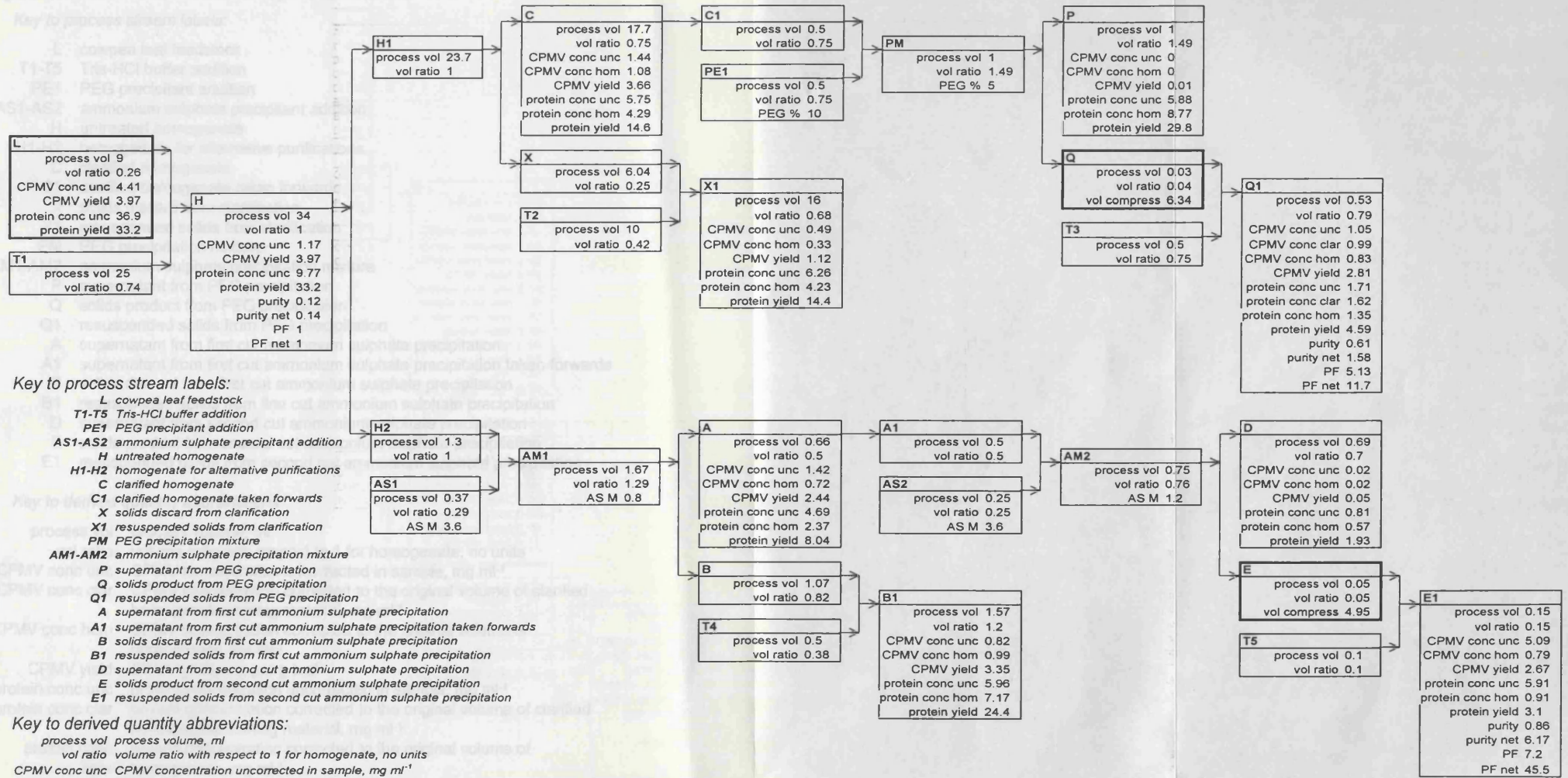

Key to process stream labels:

- L cowpea leaf feedstock
- T1-T5 Tris-HCl buffer addition
- PE1 PEG precipitant addition
- AS1-AS2 ammonium sulphate precipitant addition
- H untreated homogenate
- H1-H2 homogenate for alternative purifications
- C clarified homogenate
- C1 clarified homogenate taken forwards
- X solids discard from clarification
- X1 resuspended solids from clarification
- PM PEG precipitation mixture
- AM1-AM2 ammonium sulphate precipitation mixture
- P supernatant from PEG precipitation
- Q solids product from PEG precipitation
- Q1 resuspended solids from PEG precipitation
- A supernatant from first cut ammonium sulphate precipitation
- A1 supernatant from first cut ammonium sulphate precipitation taken forwards
- B solids discard from first cut ammonium sulphate precipitation
- B1 resuspended solids from first cut ammonium sulphate precipitation
- D supernatant from second cut ammonium sulphate precipitation
- E solids product from second cut ammonium sulphate precipitation
- E1 resuspended solids from second cut ammonium sulphate precipitation

Key to derived quantity abbreviations:

- process vol process volume, ml
- vol ratio volume ratio with respect to 1 for homogenate, no units
- CPMV conc unc CPMV concentration uncorrected in sample, mg ml⁻¹
- CPMV conc clar CPMV concentration corrected to the original volume of clarified homogenate starting material, mg ml⁻¹
- CPMV conc hom CPMV concentration corrected to the original volume of homogenate, mg ml⁻¹
- CPMV yield CPMV yield, mg per g leaf
- protein conc unc protein concentration uncorrected in sample, mg ml⁻¹
- protein conc clar protein concentration corrected to the original volume of clarified homogenate starting material, mg ml⁻¹
- rotein conc hom protein concentration corrected to the original volume of homogenate, mg ml⁻¹
- protein yield protein yield, mg per g leaf
- purity relative amount of CPMV compared to protein, no units
- purity net relative amount of CPMV compared to non-CPMV protein, no units
- PF stage purity compared to homogenate purity, no units
- PF net stage purity net compared to homogenate purity net, no units

11.4.2 Recombinant muc14-CPMV

Figure 46. Recombinant muc14-CPMV process flowsheet.

Key to process stream labels:

L	cowpea leaf feedstock
T1-T5	Tris-HCl buffer addition
PE1	PEG precipitant addition
AS1-AS2	ammonium sulphate precipitant addition
H	untreated homogenate
H1-H2	homogenate for alternative purifications
C	clarified homogenate
C1	clarified homogenate taken forwards
X	solids discard from clarification
X1	resuspended solids from clarification
PM	PEG precipitation mixture
AM1-AM2	ammonium sulphate precipitation mixture
P	supernatant from PEG precipitation
Q	solids product from PEG precipitation
Q1	resuspended solids from PEG precipitation
A	supernatant from first cut ammonium sulphate precipitation
A1	supernatant from first cut ammonium sulphate precipitation taken forwards
B	solids discard from first cut ammonium sulphate precipitation
B1	resuspended solids from first cut ammonium sulphate precipitation
D	supernatant from second cut ammonium sulphate precipitation
E	solids product from second cut ammonium sulphate precipitation
E1	resuspended solids from second cut ammonium sulphate precipitation

Key to derived quantity abbreviations:

process vol	process volume, ml
vol ratio	volume ratio with respect to 1 for homogenate, no units
CPMV conc unc	CPMV concentration uncorrected in sample, mg ml ⁻¹
CPMV conc clar	CPMV concentration corrected to the original volume of clarified homogenate starting material, mg ml ⁻¹
CPMV conc hom	CPMV concentration corrected to the original volume of homogenate, mg ml ⁻¹
CPMV yield	CPMV yield, mg per g leaf
protein conc unc	protein concentration uncorrected in sample, mg ml ⁻¹
protein conc clar	protein concentration corrected to the original volume of clarified homogenate starting material, mg ml ⁻¹
protein conc hom	protein concentration corrected to the original volume of homogenate, mg ml ⁻¹
protein yield	CPMV yield, mg per g leaf
purity	relative amount of CPMV compared to protein, no units
purity net	relative amount of CPMV compared to non-CPMV protein, no units
PF	stage purity compared to homogenate purity, no units
PF net	stage purity net compared to homogenate purity net, no units

Figure 46. Recombinant muc14-CPMV process flowsheet.

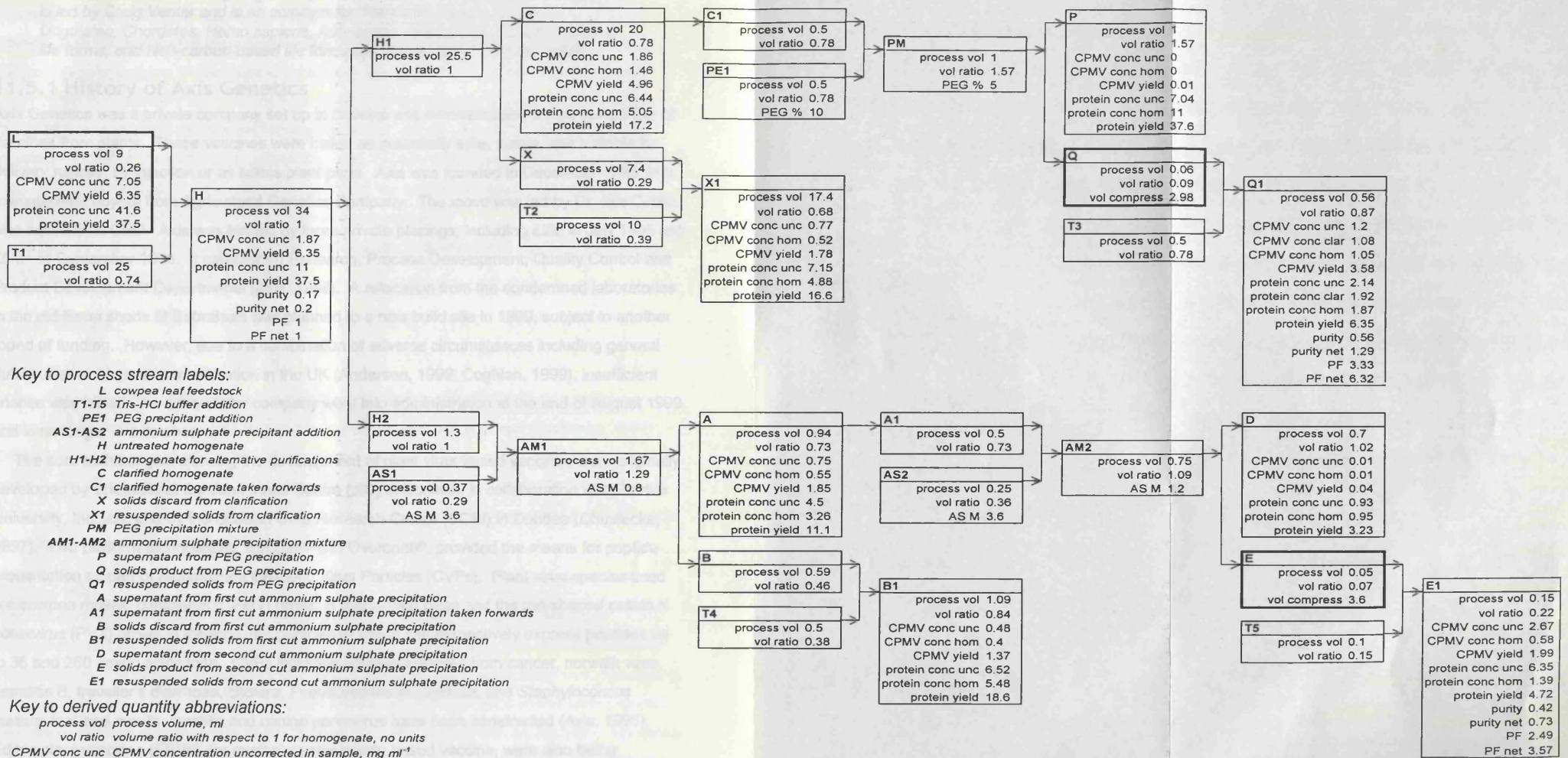

Key to process stream labels:

- L cowpea leaf feedstock
- T1-T5 Tris-HCl buffer addition
- PE1 PEG precipitant addition
- AS1-AS2 ammonium sulphate precipitant addition
- H untreated homogenate
- H1-H2 homogenate for alternative purifications
- C clarified homogenate
- C1 clarified homogenate taken forwards
- X solids discard from clarification
- X1 resuspended solids from clarification
- PM PEG precipitation mixture
- AM1-AM2 ammonium sulphate precipitation mixture
- P supernatant from PEG precipitation
- Q solids product from PEG precipitation
- Q1 resuspended solids from PEG precipitation
- A supernatant from first cut ammonium sulphate precipitation
- A1 supernatant from first cut ammonium sulphate precipitation taken forwards
- B solids discard from first cut ammonium sulphate precipitation
- B1 resuspended solids from first cut ammonium sulphate precipitation
- D supernatant from second cut ammonium sulphate precipitation
- E solids product from second cut ammonium sulphate precipitation
- E1 resuspended solids from second cut ammonium sulphate precipitation

Key to derived quantity abbreviations:

- process vol process volume, ml
- vol ratio volume ratio with respect to 1 for homogenate, no units
- CPMV conc unc CPMV concentration uncorrected in sample, mg ml⁻¹
- CPMV conc clar CPMV concentration corrected to the original volume of clarified homogenate starting material, mg ml⁻¹
- CPMV conc hom CPMV concentration corrected to the original volume of homogenate, mg ml⁻¹
- CPMV yield CPMV yield, mg per g leaf
- protein conc unc protein concentration uncorrected in sample, mg ml⁻¹
- protein conc clar protein concentration corrected to the original volume of clarified homogenate starting material, mg ml⁻¹
- protein conc hom protein concentration corrected to the original volume of homogenate, mg ml⁻¹
- protein yield protein yield, mg per g leaf
- purity relative amount of CPMV compared to protein, no units
- purity net relative amount of CPMV compared to non-CPMV protein, no units
- PF stage purity compared to homogenate purity, no units
- PF net stage purity net compared to homogenate purity net, no units

11.5 Intellectual Property

"In fact, there was a strong negative opinion for the PAT BUCHANAN group, which is led by Craig Venter and is an acronym for 'Patent All Things - Bacteria, Ungulates, Chordates, Homo sapiens, Arthropods, Nematodes, All carbon-based life forms, and Non-carbon-based life forms too, just in case" (Fricker, 2000)

11.5.1 History of Axis Genetics

Axis Genetics was a private company set up to develop and commercialise a new generation of vaccines from plants. These vaccines were hailed as potentially safe, stable, and suitable for delivery nasally, by injection or as edible plant parts. Axis was founded in December 1993, in a management buyout from Agricultural Genetics Company. The move was led by Dr. Iain Cubitt, who became its CEO. Axis was funded by three private placings, including £2M in July 1995 and £5M+ in September 1996. It established Research, Process Development, Quality Control and Product Development Departments (Axis, 1998). A relocation from the condemned laboratories in the old llama sheds at Babraham was planned to a new build site in 1999, subject to another round of funding. However, due to a combination of adverse circumstances including general public unease at genetic modification in the UK (Anderson, 1999; Coghlan, 1999), insufficient finance was raised. As a result, the company went into administration at the end of August 1999 and is no longer in existence.

The core technologies allowing the development of plant virus based vaccines were originally developed by scientists at the John Innes Centre (JIC) in Norwich, in collaboration with Purdue University, Indiana; and by the Scottish Crop Research Centre (SCRI) in Dundee (Chustecka, 1997). Two platform technologies, Epicoat® and Overcoat®, provided the means for peptide presentation as part of recombinant Chimeric Virus Particles (CVPs). Plant virus species used are cowpea mosaic *comovirus* (CPMV) grown in black-eyed bean and the rod-shaped potato *X potexvirus* (PVX) grown in tobacco, the particles of which can respectively express peptides up to 36 and 280 amino acids long. CVPs including disease epitopes from cancer, norwalk virus, hepatitis B, traveller's diarrhoea, cholera, *Pseudomonas aeruginosa*, and *Staphylococcus aureus*; foot-and-mouth, mastitis and canine parvovirus have been constructed (Axis, 1998). Edible plant vaccines (EPVs), for example a raw potato based vaccine, were also being developed in collaboration with Charles Arntzen's group at the Boyce Thompson Institute for Plant Research in Ithaca, New York. Axis retained exclusive rights to any vaccines for human use arising from this research.

Axis planned to commercialise its human vaccine product candidates through strategic partners already possessing significant presence in target markets. Axis would carry out Phase

I/II clinical trials, and for each successful candidate, a partner would be sought to purchase licence rights, complete clinical development and deal with registration and marketing of future products. Axis would retain manufacturing rights to supply the bulk actives, in order to take advantage of the anticipated cost effectiveness of production at scale thought to be offered by the plant growth system. To partners with peptides and proteins of pharmaceutical potential, Axis offered the possibility of producing customised CVPs within two to three months, with the facility to provide sufficient quantities for preclinical evaluation (Axis, 1997). In the case of veterinary vaccines, Axis intended to enter into early collaborative agreements with partners prior to product trials, in order to generate early revenues, the approvals process for veterinary vaccines also being shorter than that for human therapeutics.

Its own clinical trials of human vaccines were repeatedly delayed and this lack of progress contributed to its eventual loss of credibility.

11.6 Safety

11.6.1 MAFF

Comoviruses such as CPMV have narrow host ranges and restricted distribution. Most are transmitted horizontally in the field by beetles and some vertically via seed (Matthews, 1991). CPMV particularly can infect a range of species to produce mild symptoms, but the disease is neither naturally occurring nor found to spread in the field in US or European temperate climates. However, as a potential plant pathogen, its contained use at UCL was regulated by MAFF under Licence No. PHL 56/2503(12/1997), annually renewed.

11.6.2 HSE

Recombinant organisms such as the muc-CPMV construct used are subject to hazard assessment and risk evaluation. "The risk of an adverse immune response to CPMV CVPs is effectively zero," according to Axis' (unpublished) risk assessment, which continues; "Intentional immune responses, if they occur (not all CVPs have been shown to elicit an immune response), take place following administration of a high dose of CVPs together with an adjuvant. Accidental immune responses are unlikely to occur following occupational or environmental exposure to low amounts of CVPs, particularly in the absence of adjuvant."

"Cowpeas, the natural host of CPMV, provide more than half the plant protein for human diets in areas of the semi-humid tropics. As a food, it is consumed as dry seeds, green pods, green seeds and young green leaves. The haulms are fed to animals. Plant viruses are present in a wide variety of plants which are used as food, and humans and other animals have been

ingesting plant viruses ever since they started eating plants. Plant viruses have never been shown to cause toxicity to animals or man. The risk of toxicity to man or animals of CPMV is effectively zero."

Mucin - human mucin (muc1, muc14) is often expressed by cancer cells of epithelial origin and is a potential target for cancer immunotherapy. A repeating 20 amino acid peptide has been identified as a key component. Antibodies from breast cancer patients recognise this peptide. In normal cells it is hidden from the immune system by glycosylation. A Phase I trial has been completed based on a peptide containing 5 repeats of this sequence given with BCG (Goydos *et al.*, 1996) with the conclusion that the peptide was safe.

11.6.3 UCL

Hazards were presented by the laboratory chemicals used but risks were minimised by using good laboratory practice and following College and Departmental risk assessment and safe working procedures throughout.

11.7 Economics

*"The vogue for exaggerating progress in the hope of securing another short-term grant makes many universities an uncomfortable environment for a free spirit."
(Ford, 2000)*

The BBSRC grant application in 1996 allowed £134k in staffing costs, £5k in travel, £37k in consumables, £33k in equipment, and £54k in indirect costs over 3 years - a total of £263k.

Salaries at UCL and salary-associated overheads (pension, NI, administrative), accounted for the full amount applied for: RA1A £71k in total, technician £56k, secretarial support £7k.

Negligible cost of one overnight visit to national conference. £3k spent on laboratory consumables. £5k of equipment (-80°C freezer) was purchased. Buildings overheads (heating, services, maintenance, computing facilities) would be included in indirect costs as applied for.

Limited information was available on Axis' costs, detailed in LINK reports - year 1 est. £84k actual £110k, yr 2 est. £100k, yr 3 est. £79k. These came from a separate budget*.

11.8 Author Contact Details

M. E. Kalani Nichols, Research Fellow in Biotechnology, SPINDIGO project

School of Plant Sciences, The University of Reading, Reading RG6 6AS

phone (0118) 931 6085 fax (0118) 931 6577 email m.e.k.nichols@reading.ac.uk

* often the commercial partner provides matching funding in the form of goods and services (here, purified virus, detection antibodies, and plant growth facilities), while the research council finances the academic institution's costs

11.9 Further Processing

Freeze-thaw, homogenisation or bead-milling have been used for disruption (for extraction); ammonium sulphate salting-out or polyethylene glycol neutral polymer for precipitation (for concentration and purification). Further unit operations will be required for the complete purification and recovery of plant virus particles, such as the CPMV-based CVPs, for their intended use as vaccines. In the continued absence of reports on any potentially large-scale purification procedure it is worthwhile to briefly consider the options available:

11.9.1 Avoidance

Edible vaccines might afford an attractive option for avoiding altogether the necessity for extraction and purification of the virus-based particles. Fresh or dried leaves might directly provide an all-in-one packaging and dosage formulation. The non-enveloped virus may be stable enough to resist some degree of leaf autolysis during chilled storage or drying. However, it is not known how the labile surface antigenic loops might be affected (these have been reported to be cleaved *in planta*). Damage may reduce the therapeutic value or alter the effective dosage. Therefore, it is likely that in order to control the dose and quality, processing coupled to analytical quality control will be required.

11.9.2 Alternative Extraction

Other methods of extraction may be possible from whole leaves, such as electroporation, electro-extraction, vacuum or pressure treatment, sonication, enzyme digestion or cooking. The aim of bypassing wholesale tissue homogenisation is to avoid impurities derived from fine tissue fragments. For example, heat treatment increases the fluidity of cell membranes until they become leaky to solutes and small molecules, while collapsing the waxy coating of leaves and dissolving out some cell wall constituents: insoluble contaminants are not released into the extract.

A reduction in expected yield would offset any gain in purity. Unfortunately the ideal scenario of a single puncture in every cell sufficient to release the entire intracellular content of CPMV but nothing else seems unattainable. The known intracellular membrane-association (for replication, Carette *et al.*, 2002) of large numbers of CPMV particles might not allow sufficient disruption without homogenisation.

Solvents other than the aqueous buffer used here might be employed: organic liquids, solvent mixtures, supercritical CO₂, or steam. As the virus is soluble in water, which is cheapest to obtain and suitable for hydrophilic molecules, this is the most likely bulk process liquid to use.

If CVPs can be extracted more efficiently in another polar solvent (such as ethanol), then that may be worth considering (small volumes of volatile solvent can be recycled and reused more easily than dilute aqueous buffers). Volatile buffers (e.g. ammonium carbonate for pH 5-7 as used here), are available although often impractical even on the lab scale (Cannell, 1998).

11.9.3 Precipitation

Alternative or additional protein precipitation techniques include isoelectric point precipitation (IEP). In IEP, the net surface charge on a proteinaceous product (such as a CVP) is neutralised by adjustment of the pH, allowing hydrophobic attractions to dominate, so the particles aggregate and precipitate out. As with the precipitation techniques tested, the solid product may consist of a mixture of proteinaceous species. Reducing the solution ionic strength (within the salting-in range), e.g. by dilution, assists precipitation by this mechanism.

Inert solvent, polymer or miscible organics can also be added to an aqueous extract, for a similar effect (also caused by volume exclusion) to that of salting-out.

11.9.4 Solvent Partitioning

Immiscible organic solvent or concentrated aqueous polymer or high-salt solutions may be added to an impure aqueous extract containing CVPs. Product enrichment would be achieved by preferential partitioning between the phases of the product and impurities in opposite directions. The two-phase system may be aqueous-organic, e.g. with the food-safe ethyl acetate, or aqueous-aqueous, such as PEG-dextran or PEG-salt. Solvents may be combined with chromatography steps (see later) to minimise intermediate buffer-changing steps.

The solvent-solubility or -stability of CPMV is not known.

11.9.5 Filtration

Simple cleaning of a homogenized extract may use depth filtration equivalent to the lab-scale 'several layers of muslin', to remove leaf tissue and cell fragments as small as chloroplasts (of the order of 1 μ m). Depth filtration is inexpensive and, in the form of an in-line filter mat, can even be suitable for continuous processing. But there is a need to ensure that virus is not adsorbed to the fibrous discard, causing excessive losses.

CVPs could then be passed, in microfiltration, through a low molecular weight cut off (MWCO) membrane to separate them from larger molecules and debris. A carefully chosen ultrafiltration membrane could further retain them while smaller solutes (<28nm) were washed through. Fouling or surface blockage of these fine filters may be reduced by crossflow operation; intermittent backwashing; or specially textured vortex-assisting filter surfaces.

11.9.6 Chromatography

Chromatography describes processes in which mobility due to an applied force or condition (gravity, electrical potential, pressure, solubility) vies with attraction to a stationary phase (paper, crystals, gel, resin beads) resulting in the separation of different compounds according to their properties (charge, size, shape, hydrophobicity), at scales from analytical to preparative. On a large scale, a particulate stationary phase may be used loose for batch mixing and simple decantation, or packed into a vertical column for efficient loading and elution of the product stream. Empirical testing of a variety of alternatives will be necessary for method development.

Chromatography allows concentration of the desired product from a dilute extract into a small volume of (possibly a completely different) elution buffer. Strategies for elution (disrupting binding without denaturing the product) include buffer exchange, dilution, varying salt concentration, temperature or pH, or adding a surface-tension reducing agent (Scopes, 1994).

Direct application of homogenate to expanded bed adsorption (EBA) in process-scale chromatography may be feasible. EBA is unique among chromatographic techniques in its use extremely early in purification. Its upflow direction of operation fluidises the adsorbent particles in the process fluid, allowing separation of soluble product (which binds to adsorbent) from fairly coarse solids (which pass through the large gaps) without blocking the column. Washing is first upwards (to remove the largest solids) then down, and elution is also in the downflow direction, as for conventionally packed columns.

Other chromatographic procedures first require the homogenate to be clarified, by centrifugation, filtration or another method.

Nonspecific adsorbents which could be tested include alumina; bentonite; calcium phosphate, including hydroxyapatite; titanium dioxide; and zinc hydroxide gel. Other unmodified support chemistries include those of silica gel (exposed hydroxyls offer H-bonding sites, but it dissolves in water \geq pH 7); polyacrylamide (spoilage-resistant, such as BioRad's Biogel); polysaccharides (cellulose; Pharmacia's dextran Sephadex, or agarose Sepharose); and polystyrene (good at absorbing tannins). These base materials can be further decorated with functional groups to modify their interactions, for example silica gel with added polar groups ('bonded normal phase') or straight-chain alkyl or phenyl silanes ('reverse phase') for hydrophobicity. (Scopes, 1994)

Adsorption to styrene, as seen here during ELISA assay development, could be used as a basis for purification. Polystyrene stationary phases are available with varying degrees of ionic or hydrophobic character. In general, binding should be tighter for the compound of interest than the impurities to be separated – or vice versa (this uses more adsorbent) – although excessively tight binding makes elution or cleaning more difficult.

In ion exchange chromatography (IEX), in this case anion exchange chromatography (AEX), the negatively charged (in neutral buffer) CVPs would be adsorbed to a suitably (+) charged chromatographic support. The sorbent consists of a polymeric resin containing charged groups and mobile counterions which can be exchanged with product ions carried in the mobile phase. Separation is according to the differing affinity of ionic components present for the stationary phase. After non-binding contaminants have passed through, the purified CVPs may be eluted in a high-salt buffer, or potentially by pH adjustment to their IEP (but see earlier).

Reverse-phase hydrophobic interaction chromatography (RP-HIC) using silica gel or organic polymers (XAD-series) can be used for desalting (or buffer exchange). The aqueous product solution is loaded onto the column; excess salts washed out with water; then organic, hydrophobic or uncharged species eluted with a suitable solvent or mixture containing organic solvents. This is all providing the CVPs have sufficient hydrophobic character under non-denaturing conditions. (They are believed to be unstable when at net neutral charge, the reason for avoiding isoelectric point precipitation.)

Size-exclusion chromatography (SEC) can also be used for desalting. Here, the major effect is physical rather than chemical. Inorganic ions, being the smallest, are retarded relative to large particles by, on average, a more tortuous passage through the column matrix. For cleaning-up the CPMV extract, large and hydrophobic contaminants such as chlorophylls would pass through more quickly than small CVPs, which themselves would emerge before the high-salt fraction.

In all chromatography, because multiple factors influence separation, behaviour may vary from what might be predicted. Elution in the reverse order from that expected is not uncommon.

Affinity chromatography is a powerful technique with intense specificity. In the same way as antibodies were used in the ELISA to quantitatively bind CPMV or a particular CVP in its active form, antibody-derivatised chromatography supports could readily effect physical separation of virus vaccine particles. This is the only technique which would be expected to distinguish between antigenic variants of CVPs, should they become mixed or degenerate during infection or processing. Elution can be assisted by using a buffer containing free antibody.

11.9.7 Additional References

Cannell, R.J.P., ed. 1998. Methods in Biotechnology Vol. 4: Natural Products Isolation. Totowa, NJ, USA: Humana Press, Inc. 473pp.

Carette, J.E.; Guhl, K.; Wellink, J.; Van Kammen, A. 2002. Coalescence of the sites of cowpea mosaic virus RNA replication into a cytopathic structure. *Journal of Virology* **76**(12):6235-6243.

Scopes, R.K. 1994. Protein Purification: Principles and Practice, 3rd edition. New York: Springer-Verlag. 380pp.