

1 **Title:** *Negligible influence of moderate to severe hyperthermia on blood-brain barrier*
2 *permeability and neuronal-parenchymal integrity in healthy men*

3
4 **Authors:**

5
6 ¹Brooke R. Shepley, ²Philip N Ainslie, ^{2,3}Ryan L. Hoiland, ⁴Joseph Donnelly, ^{2,5}Myrinder S.
7 Sekhon, ^{6,7,8,9}Henrik Zetterberg, ^{6,7}Kaj Blennow, ¹Anthony R. Bain*

8
9 **Affiliations:**

10
11 ¹University of Windsor, Faculty of Human Kinetics, Department of Kinesiology

12
13 ²University of British Columbia, Kelowna, Centre for Heart Lung and Vascular Health

14
15 ³Department of Anesthesiology, Pharmacology, and Therapeutics, Vancouver General Hospital,
16 899 West 12th Avenue, Vancouver, BC, Canada, V5Z 1M9

17
18 ⁴Brain Physics Laboratory, Division of Academic Neurosurgery, Department of Clinical
19 Neurosciences, Addenbrookes Hospital, University of Cambridge, Cambridge, UK

20
21 ⁵Division of Critical Care Medicine and Department of Medicine, University of British
22 Columbia, Vancouver, BC, Canada

23
24 ⁶Department of Psychiatry and Neurochemistry, Institute of Neuroscience and Physiology, the
25 Sahlgrenska Academy at the University of Gothenburg, Mölndal, Sweden

26
27 ⁷Clinical Neurochemistry Laboratory, Sahlgrenska University Hospital, Mölndal, Sweden

28
29 ⁸Department of Neurodegenerative Disease, UCL Institute of Neurology, Queen Square, London,
30 UK

31
32 ⁹UK Dementia Research Institute at UCL, London, UK

33
34
35
36
37 **Contact Author:**

38
39 Anthony R. Bain, PhD
40 University of Windsor, Faculty of Human Kinetics
41 Anthony.bain@uwindsor.ca

42
43 **Running Header:**

44
45 *Heat stress and the neurovascular unit*

47 *New & Noteworthy:*

48

- 49 • The acute effects of passive whole-body hyperthermia on the integrity of the
50 neurovascular unit (NVU) in humans have remained unclear.
- 51 • We demonstrate that passive heating for ~one hour until an increase of +2°C esophageal
52 temperature in healthy men does not increase the cerebral release of neuronal
53 parenchymal stress biomarkers, suggesting the NVU integrity is maintained.
- 54 • This preliminary study indicates passive heating is safe for the brain, at least in young
55 healthy men.

56 **Abstract:**

57 With growing use for hyperthermia as a cardiovascular therapeutic, there is surprisingly little
58 information regarding the acute effects it may have on the integrity of the neurovascular unit
59 (NVU). Indeed, relying on animal data would suggest hyperthermia comparable to levels
60 attained in thermal therapy will disrupt the blood-brain barrier (BBB) and damage the cerebral
61 parenchymal cells. We sought to address the hypothesis that controlled passive hyperthermia is
62 not sufficient to damage the NVU in healthy humans. Young men (n=11) underwent acute
63 passive heating until +2°C or absolute esophageal temperature of 39.5°C. The presence of BBB
64 opening was determined by trans-cerebral exchange kinetics (radial-arterial and jugular venous
65 cannulation) of S100B. Neuronal parenchymal damage was determined by the trans-cerebral
66 exchange of tau protein, neuron specific enolase (NSE) and neurofilament-light protein (NF-L).
67 Cerebral blood flow to calculate exchange kinetics was measured by duplex ultrasound of the
68 right internal carotid and left vertebral artery. Passive heating was performed via warm-water
69 perfused suit. In hyperthermia, there was no increase in the cerebral exchange of S100B
70 (p=0.327), tau protein (p=0.626), NF-L (p=0.447) or NSE (p=0.908) suggesting +2°C core
71 temperature is not sufficient to acutely stress the NVU in healthy men. However, there was a
72 significant condition effect (p=0.028) of NSE, corresponding to a significant increase in arterial
73 (p=0.023) but not venous (p=0.173) concentrations in hyperthermia, potentially indicating extra-
74 cerebral release of NSE. Collectively, results from the present study support the notion that in
75 young men there is little concern for NVU damage with acute hyperthermia of +2°C.

76

77

78 **Keywords:** Heat stress, Brain, neurovascular unit

79 ***Introduction***

80

81 The use of heat stress, or heat *therapy*, as a remedial and prophylactic tool for cardiovascular
82 health has gained recent attention [reviewed in (15)]. While heat, or fever, as a non-specific
83 therapeutic has been touted since Hippocrates (8), the interest in the potential cardiovascular
84 benefits of heat have largely stemmed from epidemiological studies linking frequent sauna use to
85 a reduced incidence of cardiovascular events and vascular disease (32-35). Supporting the
86 epidemiology data is a growing number of experimental-based studies suggesting a direct benefit
87 of transient heat stress on vascular endothelial function. For example, Brunt et al. (12) reported
88 that eight weeks of passive heat therapy, via hot water immersion, improved vascular function in
89 young, sedentary adults: specifically, increased brachial artery flow-mediated dilation and
90 reduced resting blood pressure. Moreover, in clinical models, heat therapy has been
91 demonstrated to improve cardiac function and increase exercise tolerance in heart failure (27,
92 39), myocardial perfusion in coronary artery disease (21, 54) and extremity perfusion in
93 peripheral artery disease (1, 53, 55).

94

95 What remains to be determined is whether heat therapy can be used as a cerebral vascular
96 therapeutic, particularly of the neurovascular unit (NVU). A major component of the NVU is the
97 cerebral microvasculature, along with the surrounding parenchymal cells. That is, the NVU
98 consists of endothelial cells, associated blood-brain barrier (BBB) tight junctional proteins,
99 pericytes, astrocytes, and neurons, among others (24). It is often assumed that the reported
100 beneficial impacts of heat therapy on the peripheral vasculature also reflect improvements to the
101 cerebral vasculature (14, 19, 43), and improvements of the entire NVU since chronic heat

102 therapy has been associated with a reduced incidence of vascular dementia (33). However, this
103 assumption may be misleading considering the peripheral vs. cerebral vascular beds experience
104 markedly different stressors in acute hyperthermia. For example, during heat stress the peripheral
105 endothelium is exposed to increases in beneficial anterograde shear stress [i.e., increased
106 forward moving blood flow (22)], while the cerebral endothelium is exposed to reduced
107 anterograde shear (i.e., reduced forward-moving blood flow) secondary to cerebral
108 vasoconstriction as a result of respiratory alkalosis (7). Moreover, hyperthermia which
109 encroaches an absolute core temperature of 40°C may selectively become cytotoxic to the
110 delicate cells of the CNS compared to vascular cells in the periphery (50). Additionally, whole-
111 body hyperthermia exceeding 38.5°C [(a core temperature elevation well within the realm of heat
112 therapy (34)] is recognized to increase the permeability of the BBB in rodent models (52, 28).
113 Importantly, a compromised BBB has the potential to alter the extracellular environment and
114 thereby induce damage to other parts of the NVU by means of neuroinflammation, edema, and
115 ionic imbalances (42).

116

117 Increased permeability of the BBB in humans is often assessed by circulating concentrations of
118 S100B, a ~11 kDa astroglial protein, that has to cross the BBB to enter the bloodstream. Its
119 presence in the peripheral circulation is, in turn, generally reflective of a leaky BBB (62). To
120 date, in humans, there remains little data on the release of S100B in whole-body hyperthermia,
121 with the bulk of data derived from exercise-induced heat stress. For example, Watson et al. (62)
122 demonstrated that peripherally circulating concentrations of S100B is increased during
123 hyperthermic exercise (~2°C increase in core temperature). Conversely, Chevront et al. (16)
124 observed no mean increase in circulating S100B during hyperthermic exercise, with temperature

125 elevations of $\sim 1.5^{\circ}\text{C}$ while walking in the heat. Apart from the small difference in core
126 temperature, a few alternative explanations may be offered for these data. Most notably, while
127 the majority of S100B is of cerebral origin, it can additionally be released from stressed cardiac
128 and skeletal muscle, which may be exacerbated with hyperthermia (62). The increase in S100B
129 during hyperthermic exercise reported by some (60-62) may therefore, in part, reflect an increase
130 in extra-cerebral sources, rather than BBB opening. Indeed, Watson et al., (62) had participants
131 cycle at 60% of VO_2 peak, whereas participants were walking in Chevront et al., (16). Until the
132 present study, there has been a paucity of data on the independent impact of heat stress – i.e.,
133 passive hyperthermia – on BBB leakage and subsequent health of the neuronal parenchyma and
134 entire NVU in humans.

135
136 Given that hyperthermia of up to $+2^{\circ}\text{C}$ core temperature [i.e., during hot yoga, Finnish sauna or
137 Waon therapy (15)] has gained widespread attention as a tool to improve cardiovascular
138 function, there is a need to confirm that this level of heating is safe for the NVU. Accordingly,
139 the purpose of this study was to determine the trans-cerebral arterial-venous kinetics of S100B
140 (an established marker of BBB permeability) in passive hyperthermia, as well as concurrent
141 biochemical metrics of the NVU function as indexed by an established clinical panel for cerebral
142 damage; tau protein, neuron specific enolase (NSE) and neurofilament-light protein (NF-L) (26,
143 57, 59). Based on our previous observation (6) that passive hyperthermia does not evoke a robust
144 increase in the cerebral release of inflammatory and pro-oxidative markers in humans (a tenable
145 mechanism for BBB opening), we hypothesized that acute passive hyperthermia of $+2^{\circ}\text{C}$ core
146 temperature in healthy young men would not elicit marked BBB opening as determined by the

Heat stress and the neurovascular unit

- 147 trans-cerebral release of S100B, or detectable cerebral parenchymal damage determined by the
- 148 release of tau protein, NSE, and NF-L.
- 149

150 **Methods**

151 *Subjects and ethical approval:*

152

153 Eleven healthy young men (age 23 ± 3 years) participated in the study. All subjects were non-
154 obese (body mass index 23.0 ± 2.1 kg/m), normotensive ($118/71 \pm 6/7$ mmHg), normoglycemic
155 (<7.0 mmol/L), non-smoking and free of overt cardiometabolic and respiratory disease (all
156 variables are mean \pm SD). All experimentation was completed at the Centre for Heart, Lung &
157 Vascular Health, University of British Columbia, Kelowna, BC, Canada. The ethical committee
158 of the University of British Columbia approved the study (H15-00166). The study conformed to
159 the standards set by the *Declaration of Helsinki*, except registry in a database. All subjects
160 provided informed written consent before experimentation. Subset measures from this study have
161 been published elsewhere under separate experimental questions relating to circulating
162 microvesicles (3), and cerebral metabolism (6). The present study encompasses separate *a-priori*
163 hypotheses.

164

165 *Experimental protocol:*

166 Subjects arrived at the laboratory after a 4 to 12 hr fast and minimum 12 hr abstinence from
167 alcohol and caffeine-containing beverages. Under local anaesthesia (1% lidocaine) and
168 ultrasound guidance, a 20-gauge arterial catheter (Arrow, Markham, ON, Canada) was placed in
169 the right radial artery, and a central venous catheter (Edwards PediaSat Oximetry Catheter, CA,
170 USA) was placed in the right internal jugular vein and advanced towards the jugular bulb.
171 Following cannulation, subjects were fitted into a tube-lined suit (Med-Eng, Ottawa, ON,
172 Canada) that covered the entire body except for the head, feet and hands. The tube-lined suit was

Heat stress and the neurovascular unit

173 perfused with $\sim 49^{\circ}\text{C}$ water until an esophageal temperature of $+2^{\circ}\text{C}$ above baseline, an absolute
174 core temperature of 39.5°C , or the subject's volitional thermal tolerance was reached. Core
175 temperature (Teso) was determined by a thermocouple probe (RET-1; Physitemp Instruments,
176 Clifton, NJ, USA) that was inserted 40 cm past the nostril into the esophagus. Blood samples
177 were collected into vacutainers containing ethylenediaminetetraacetic acid (EDTA) for
178 separation of plasma and quantification of tau, as well as tubes containing no anticoagulant for
179 analysis of S100B, NSE and NF-L. Samples were collected simultaneously from the radial artery
180 and jugular bulb immediately before heating (normothermic) and at $+2^{\circ}\text{C}$ core temperature. A
181 time-control group was not incorporated into the experimental design given previous reports
182 demonstrating no time effect of the cross-brain measures (4, 5).

183 *Cardiovascular and cerebrovascular measures:*

184 Blood flow in the right internal carotid artery (ICA) and left vertebral artery (VA) was
185 simultaneously measured using duplex vascular ultrasound (Terason 3200, Teratech, Burlington,
186 MA), and used to calculate global cerebral blood flow; $(\text{ICA} \times 2) + (\text{VA} \times 2)$. The right ICA
187 was on average insonated 2cm from the carotid bifurcation, while the left VA was insonated at
188 the C5–C6 or C4–C5 space depending on the subject's unique anatomy. The steering angle was
189 fixed to 60 degrees for all measures, and the sample volume was placed in the center of the
190 vessel adjusted to cover the entire vascular lumen. All files were screen-captured and saved as
191 video files for offline analysis at 30Hz using custom-designed software (63). Simultaneous
192 measures of luminal diameter and velocity over a minimum of 12 cardiac cycles were used to
193 calculate blood flow. The within-day coefficient of variation for the ICA and VA blood flow was
194 7% and 4%, respectively. Heart rate (HR) was obtained from the R-R intervals measured in lead

195 II of the ECG. Mean arterial blood pressure (MAP) was measured with a pressure transducer
196 connected to the radial catheter.

197 *NVU biomarker analysis:*

198 Serum S100B and plasma NSE concentrations were measured using commercially available
199 immunoassays with electrochemiluminescence detection on Cobas according to instructions
200 from the manufacturer (Roche Diagnostics, Penzberg, Germany). Serum NF-L concentration was
201 measured on a Single molecule array (Simoa) HD-1 Analyzer using the commercially available
202 NF-Light kit according to instructions from the manufacturer (Quanterix, Billerica, MA). Plasma
203 tau concentration was measured on a Simoa HD-1 Analyzer using the commercially available
204 Tau Advantage kit according to instructions from the manufacturer (Quanterix, Billerica, MA).
205 All measurements were performed in one round of experiments using one batch of reagents by
206 board-certified laboratory technicians who were blinded to clinical data. Intra-assay coefficients
207 of variation were 3-5% for S100B and NSE, 7.2% for NF-L and 11% for tau. Cerebral exchange
208 was calculated as the global cerebral blood flow x the arterial-venous difference of each
209 respective biomarker, whereby a negative value denotes cerebral release.

210 NSE, tau protein, and NF-L were used to determine cerebral parenchymal damage as they
211 collectively make up a common clinical panel for the prognosis of brain damage (23, 48, 59).

212 NSE is an enzyme that is typically found in neurons and neuroendocrine cells and has been
213 shown to upregulate following neuronal death [e.g., after a traumatic brain injury (TBI); 23, 59].

214 Similarly, tau protein and neurofilament-light protein (NF-L) are established biomarkers of brain
215 trauma; they both reside in axons that are susceptible to damage (59, 65). NF-L is composed of

216 polypeptides and provides structural axonal support, whereas tau protein provides stability to the
217 axonal microtubules (59).

218 *Statistical analysis:*

219 Analyses were performed using the statistical software package SPSS (v.22; IBM, Armonk, NY,
220 USA). Cerebral blood flow (to calculate cerebral exchange of brain proteins) was averaged over
221 20-second bins around the blood draws. Tests for normality were confirmed using repeated
222 Shapiro-Wilks W tests. Statistical analyses for all NVU biomarkers were performed using 2-way
223 [condition (baseline vs. hyperthermia), and site (arterial vs. venous)] repeated-measures
224 ANOVA. After a main effect, post hoc analyses were performed using two tailed repeated-
225 measures Student's t-tests. Effect size was calculated as Hedges' g corrected for a small sample
226 size using the formula: Hedges' $g = \frac{M1-M2}{Pooled\ SD} \times \left(\frac{N-3}{N-2.25} \right) \times \left(\sqrt{\frac{N-2}{N}} \right)$, where the mean 1 (M1) was
227 baseline, and mean 2 (M2) was heat stress. Significance was determined at an alpha level of
228 0.05. All data are presented as means \pm SD.

229

230

231

232 **Results**

233

234 *Thermometry and descriptive data:*

235

236 Absolute esophageal temperature at baseline was $37.3 \pm 0.2^\circ\text{C}$, and at peak heat stress was
237 $39.2 \pm 0.2^\circ\text{C}$. Average heating time (elapsed time between baseline and measures at peak heat
238 stress) was 58 ± 8 min. Participants were kept at peak heat stress for ~five minutes. Individual
239 core temperature for baseline and heat stress, as well as cardiovascular and cerebrovascular
240 descriptive data, is presented in Table 1.

241

242 *NVU biomarkers:*

243

244 Mean data are presented in Table 2. Individual data are presented in Figure 1, and individual
245 cerebral exchange data are presented in Figure 2. There were no effects on S100B, tau protein,
246 or NF-L across condition, site, or condition x site (p all >0.05). However, there was a significant
247 main effect of heat stress (condition) on NSE ($p=0.028$), but no significant main effect of site
248 ($p=0.910$) or interaction ($p=0.908$). Post hoc analysis revealed a significant increase in arterial
249 ($p=0.023$; Hedges' $g= -0.40$) but not venous ($p=0.173$; Hedges' $g= -0.43$) concentrations of NSE
250 from baseline to heat stress. There were no significant effects of heat stress on the cerebral
251 exchange of S100B (Hedges' $g= -0.56$), NSE (Hedges' $g= -0.14$), tau protein (Hedges' $g= -0.09$),
252 or NF-L (Hedges' $g= -0.12$) (p all >0.05).

253

254

255 *Discussion*

256

257 The primary finding of this study is that marked passive hyperthermia of $\sim 2.0^{\circ}\text{C}$ by means of
258 passive heating is not sufficient to acutely open the BBB or provoke any discernable cerebral
259 neuronal parenchymal damage in young healthy males. This finding was evidenced by an
260 unaltered cerebral exchange of S100B, NSE, tau protein, and NF-L. However, heat stress
261 increased circulating NSE in the arterial circulation, perhaps indicating contribution from non-
262 cerebral sources.

263

264 *Is $+2^{\circ}\text{C}$ Core Temperature Safe for the NVU?*

265

266 Results of the present study are timely given the recent surge in employing passive heat stress as
267 a cardiovascular therapeutic (12, 21, 27, 29, 32-36, 39, 54). In experimental use of thermal
268 therapy (e.g., sauna use), core temperature elevations of up to 2°C are often reported (34). While
269 it is generally accepted that induced heat stress should not exceed an absolute core temperature
270 of $\sim 40^{\circ}\text{C}$ [to avoid life-threatening complications of heat illness (10)], impetus for the present
271 study relates to the notion that the cerebral tissue may become damaged at a much lower
272 threshold temperature. For example, with progressive continuous heating, as employed in the
273 current study, BBB leakage in rats (assessed by stained albumin and astrocytic activation) begins
274 to occur at 38.5°C (28). Moreover, even a 1.0°C increase in core temperature is problematic for
275 cerebral outcomes in human conditions of traumatic brain injury (9, 56), likely in part related to
276 increased pro-inflammatory responses. That is, passive heat stress ubiquitously increases IL-6, a
277 known cytokine that stimulates BBB opening (60), which can induce or exacerbate damage to

278 the NVU (in the setting of TBI) by means of neuroinflammation, edema, and ionic imbalances
279 (42). Importantly, we have previously demonstrated that with +2.0°C core temperature the
280 cerebral exchange of pro-oxidative and inflammatory markers (oxidative-low density lipoprotein,
281 myeloperoxidase, and IL-6) are not increased, however, the increase in IL-6 in a sample of six
282 participants trended to selectively increase more in the cerebral tissue (6). At least in healthy
283 young males, results from the present study reassure that this trend for increases in cerebral IL-6
284 does not lend to BBB opening. (There is an absence of a relationship between jugular venous IL-
285 6 and S100B in heat stress; $r=0.454$, $p=0.219$, unpublished data, $n=10$.)

286

287 *Biomarkers for NVU Damage; Impact of Extracerebral Sources?*

288

289 The primarily astroglial protein S100B was used to quantify BBB leakage (16, 26, 60), while
290 concentrations of the CNS dominant tau protein, NF-L, and NSE were measured to provide
291 insight on neuronal parenchymal damage. While the lack of cerebral release or increase in
292 jugular venous concentrations of S100B, tau protein, NF-L and NSE collectively suggests that
293 passive heat stress up to 39.5°C core temperature in healthy young men is not sufficient to
294 acutely increase BBB permeability or damage the cerebral neuronal parenchyma; the increase in
295 NSE from BL to HS is notable. Because of the lack of cerebral exchange, this net increase in
296 NSE from baseline to heat stress may be attributed to release from non-cerebral sources, which is
297 consistent with systemic release of NSE driving a similar average but highly variable (and
298 therefore non-significant) increase in venous NSE (Figure 1). That is, the arterial increase in
299 NSE may have carried over to the cerebral venous side in some. For example, although NSE is
300 most abundant in neurons located in the brain, it is also located in neuroendocrine tissues

301 throughout the body, specifically the adrenal glands (23, 46). Hyperthermia activates the
302 hypothalamic-pituitary-adrenal axis through feedforward mechanisms (31, 41), contributing to
303 the heat-induced hyperadrenergic state (44). In turn, it has been demonstrated in rats that heat
304 stress acutely decreases adrenal cortex volume and mass with concomitant increases in
305 circulating corticotrophin and corticosterone (31). Concentrations of circulating cortisol are also
306 significantly elevated in heat-stressed humans (11, 17, 18). It is, therefore, reasonable to suggest
307 that the increase in systemic concentrations of NSE was from adrenal sources consequent to the
308 profound heat-induced excitation. Regardless of its source, however, it remains to be determined
309 whether the increase in NSE is an inert bi-product of hyperthermia, or a marker of important
310 physiologic function / malfunction. Furthermore, an important consideration is whether the
311 average increase in NSE of only ~6ng/mL (from ~13 to 19 ng/mL) has physiologic relevance.
312 For comparison, a two-fold increase in NSE (compared to controls) has been reported in humans
313 less than 48 hrs following mild traumatic brain injury (13).

314

315 *Exercise, Temperature & NVU Biomarkers:*

316

317 Exercise has been shown to increase the circulating concentration of some CNS-targeted
318 biomarkers, particularly S100B [reviewed in (30)]. It is often assumed that the exercise-induced
319 increase in S100B is indicative of BBB opening and, in part, as a consequence of the increases in
320 cerebral temperature (62) in the absence of physical head trauma. Results from the present study,
321 however, suggest that temperature alone may have a negligible impact on circulating S100B
322 from cerebral sources, at least when core temperature does not exceed ~39.5°C, and in the
323 absence of head trauma. Several alternative mechanisms may explain increased circulating

324 concentrations of S100B during exercise (30). For example, although S100B is primarily located
325 in the brain, it is also in the skeletal myofibrils and adipocytes (2, 20, 58). Indeed, S100B has
326 been shown to positively correlate with increases in creatine kinase after exercise which is
327 indicative of muscular degradation (47). However, Watson et al. (62) demonstrated that
328 peripherally circulating concentrations of S100B is higher during exercise in warm versus cold
329 conditions at the same workload. While these data certainly indicate hyperthermia as a variable
330 for the additional release of S100B, it still does not provide insight into its source. That is,
331 hyperthermic muscle may release more S100B. This notion is consistent with the present study
332 whereby no increase in S100B is observed in passive hyperthermia, notably with identical
333 elevations in core temperature to Watson et al., (62). A similar assumption may be held with
334 reported increases in NSE during long-distance running (25) – that is, increased circulating
335 concentrations from extra-cerebral sources, which is likely in part temperature-dependent.

336

337 *Limitations & Future Research:*

338

339 The data herein must be interpreted solely within the context of the study – an acute setting with
340 an average heating duration of ~1hr in young healthy adult men. Although these initial results
341 corroborate the safety of passive heating for the brain, there remain many important areas for
342 future research. Foremost, future studies should consider differences in sex, age, and in people
343 with co-morbidities. This latter group is especially important given the target population for heat
344 therapy [e.g., heart failure (21, 27, 39) and peripheral arterial disease (1, 53, 55)]. Another
345 important consideration is the acute heating stimulus and timing of measurements. In this
346 respect, concentrations of NF-L should be interpreted with the most caution. Neurofilament

347 proteins are found exclusively in neurons, which make them ideal markers for CNS injury;
348 however, their release to the circulation can be delayed by days following the initial injury (38,
349 48, 59, 65). NF-L was included in the present analysis given the unique setting to address cross-
350 brain kinetics with the potential to observe a snapshot of increased cerebral release, as opposed
351 to the conventional measures limited to the peripheral venous circulation. Nonetheless, NF-L is
352 generally classified as a ‘delayed’ axonal injury marker. On the other hand, both NSE (13, 37,
353 57) and tau protein (40, 45, 49, 64) are elevated in the acute setting of cerebral injury. We are
354 therefore confident that, collectively, our measures had the sensitivity to demonstrate cerebral
355 injury in the present study setting, had it occurred. Still, future studies should consider tracking
356 (at least in the peripheral venous system) CNS biomarkers over days following the hyperthermic
357 stress. The duration and rate of the heating stimulus should also be considered, under the premise
358 that longer heat stress durations (>1 hour) may be necessary for disruption of the BBB (51, 52).
359 Additionally, future studies should consider cross-brain measures of S100B during steady-state
360 exercise in cold or warm environments, to establish contribution from extra-cerebral sources.
361 Lastly, but importantly, future studies should consider a timed control group, especially with
362 heating conditions of longer durations. A normothermic time control group was not attainable in
363 the present study given the invasive experimental setup. However, in our previous studies (4, 5),
364 participants were cannulated for well over six hours (under varying apneic conditions), and an
365 increase in NSE was not observed. We are confident that the increase in NSE is therefore related
366 to the hyperthermia, and not a time effect.

367

368 ***Conclusion:***

369

370 In summary, passive acute heating that approaches +2°C core temperature, or absolute core
371 temperature of ~39.2°C, is not sufficient to increase the cerebral release of S100B, NSE, tau
372 protein, and NF-L. We interpret these data to indicate that, in contrast to the prevailing data in
373 rodents, this level of hyperthermia does not open the BBB and elicit damage to the neurovascular
374 unit in healthy young adult males. These preliminary data are encouraging for subsequent studies
375 aiming to extend the utility of heat therapy for improvements in cerebrovascular function.

376

377 *Acknowledgments*

378

379 ARB is supported by an NSERC DG (#RGPIN-2020-05760). HZ is a Wallenberg Scholar
380 supported by grants from the Swedish Research Council (#2018-02532), the European Research
381 Council (#681712), Swedish State Support for Clinical Research (#ALFGBG-720931), the
382 Alzheimer Drug Discovery Foundation (ADDF), USA (#201809-2016862), and the UK
383 Dementia Research Institute at UCL. KB is supported by the Swedish Research Council (#2017-
384 00915), the Alzheimer Drug Discovery Foundation (ADDF), USA (#RDAPB-201809-2016615),
385 the Swedish Alzheimer Foundation (#AF-742881), Hjärnfonden, Sweden (#FO2017-0243), the
386 Swedish state under the agreement between the Swedish government and the County Councils,
387 the ALF-agreement (#ALFGBG-715986), and European Union Joint Program for
388 Neurodegenerative Disorders (JPND2019-466-236).

389

390 **Conflicts of interest**

391

Heat stress and the neurovascular unit

392 HZ has served at scientific advisory boards for Denali, Roche Diagnostics, Wave, Samumed,
393 Siemens Healthineers, Pinteon Therapeutics and CogRx, has given lectures in symposia
394 sponsored by Fujirebio, Alzecure and Biogen, and is a co-founder of Brain Biomarker Solutions
395 in Gothenburg AB (BBS), which is a part of the GU Ventures Incubator Program (outside
396 submitted work). KB has served as a consultant, at advisory boards, or at data monitoring
397 committees for Abcam, Axon, Biogen, Julius Clinical, Lilly, MagQu, Novartis, Roche
398 Diagnostics, and Siemens Healthineers, and is a co-founder of Brain Biomarker Solutions in
399 Gothenburg AB (BBS), which is a part of the GU Ventures Incubator Program (outside
400 submitted work).

401 **References**

- 402 1. **Akerman AP, Thomas KN, Rij AMV, Body ED, Alfadhel M, Cotter JD.** Heat therapy vs.
403 supervised exercise therapy for peripheral arterial disease: a 12-wk randomized, controlled
404 trial. *American Journal of Physiology-Heart and Circulatory Physiology* 316, 2019.
405
- 406 2. **Anderson RE, Hansson L-O, Nilsson O, Liska J, Settergren G, Vaage J.** Increase in serum
407 S100A1-B and S100BB during cardiac surgery arises from extracerebral sources. *The Annals of*
408 *Thoracic Surgery* 71: 1512–1517, 2001.
409
- 410 3. **Bain AR, Ainslie PN, Bammert TD, Hijmans JG, Sekhon M, Hoiland RL, Flück**
411 **D, Donnelly J, Desouza CA.** Passive heat stress reduces circulating endothelial and platelet
412 microparticles. *Experimental Physiology* 102: 663–669, 2017.
413
- 414 4. **Bain AR, Ainslie PN, Hoiland RL, Barak OF, Cavar M, Drvis I, Stembridge**
415 **M, MacLeod DM, Bailey DM, Dujic Z, MacLeod DB.** Cerebral oxidative metabolism is
416 decreased with extreme apnoea in humans; impact of hypercapnia. *The Physiological*
417 *Society* 594: 5317–5328, 2016.
418
- 419 5. **Bain AR, Ainslie PN, Hoiland RL, Barak OF, Drvis I, Stembridge M, MacLeod**
420 **DM, McEneny J, Stacey BS, Tuailon E, Marchi N, De Maudave AFH, Dujic Z, MacLeod**
421 **DB, Bailey DM.** Competitive apnea and its effect on the human brain: focus on the redox
422 regulation of blood-brain barrier permeability and neuronal-parenchymal integrity. *FASEB*
423 *journal: official publication of the Federation of American Societies for Experimental*
424 *Biology* 32: 2305–2314, 2018.
425
- 426 6. **Bain AR, Hoiland RL, Donnelly J, Nowak-Flück D, Sekhon M, Tymko MM, Greiner**
427 **JJ, Desouza CA, Ainslie PN.** Cerebral metabolism, oxidation and inflammation in severe
428 passive hyperthermia with and without respiratory alkalosis. *The Journal of Physiology* 598:
429 943–954, 2020.
430
- 431 7. **Bain AR, Nybo LN, Ainslie Pundefined.** Cerebral Vascular Control and Metabolism in Heat
432 Stress. *Comprehensive Physiology* 5: 1345–1380, 2015.
433
- 434 8. **Bierman W.** The History of Fever Therapy in the Treatment of Disease*. *Bulletin of the New*
435 *York Academy of Medicine* 18: 65–75, 1942.
436
- 437 9. **Bonds BW, Hu P, Li Y, Yang S, Colton K, Gonchigar A, Cheriyan J, Grissom T, Fang**
438 **R, Stein DM.** Predictive value of hyperthermia and intracranial hypertension on neurological
439 outcomes in patients with severe traumatic brain injury. *Brain Injury* 29: 1642–1647, 2015.
440
- 441 10. **Bouchama A, Knochel JP.** Heat Stroke. *New England Journal of Medicine* 346: 1978–1988,
442 2002.
443
- 444 11. **Brenner I, Shek P, Zamecnik J, Shephard R.** Stress Hormones and the Immunological
445 Responses to Heat and Exercise. *International Journal of Sports Medicine* 19: 130–143, 1998.

- 446
447 12. **Brunt VE, Howard MJ, Francisco MA, Ely BR, Minson CT.** Passive heat therapy
448 improves endothelial function, arterial stiffness and blood pressure in sedentary humans. *The*
449 *Journal of Physiology* 594: 5329–5342, 2016.
450
451 13. **Buonora JE, Yarnell AM, Lazarus RC, Mousseau M, Latour LL, Rizoli SB, Baker**
452 **AJ, Rhind SG, Diaz-Arrastia R, Mueller GP.** Multivariate Analysis of Traumatic Brain Injury:
453 Development of an Assessment Score. *Frontiers in Neurology* 6, 2015.
454
455 14. **Caldwell HG, Coombs GB, Howe CA, Hoiland RL, Patrician A, Lucas SJ, Ainslie PN.**
456 Evidence for temperature-mediated regional increases in cerebral blood flow during
457 exercise. *The Journal of Physiology* 598: 1459–1473, 2020.
458
459 15. **Cheng JL, Macdonald MJ.** Effect of heat stress on vascular outcomes in humans. *Journal*
460 *of Applied Physiology* 126: 771–781, 2019.
461
462 16. **Chevront SN, Chinevere TD, Ely BR, Kenefick RW, Goodman DA, Mcclung**
463 **JP, Sawka MN.** Serum S-100 β Response to Exercise-Heat Strain before and after
464 Acclimation. *Medicine & Science in Sports & Exercise* 40: 1477–1482, 2008.
465
466 17. **Collins KJ, Few JD, Forward TJ, Giec LA.** Stimulation of adrenal glucocorticoid secretion
467 in man by raising the body temperature. *The Journal of Physiology* 202: 645–660, 1969.
468
469 18. **Follenius M, Brandenberger G, Oyono S, Candas V.** Cortisol as a sensitive index of heat-
470 intolerance. *Physiology & Behavior* 29: 509–513, 1982.
471
472 19. **Gibbons TD, Thomas KN, Wilson LC.** Is all heat equal? Implications for the stimulus for
473 adaptation in the brain. *The Journal of Physiology* 598: 2051–2052, 2020.
474
475 20. **Gonçalves CA, Leite MC, Guerra MC.** Adipocytes as an Important Source of Serum
476 S100B and Possible Roles of This Protein in Adipose Tissue. *Cardiovascular Psychiatry and*
477 *Neurology* 2010: 1–7, 2010.
478
479 21. **Gravel H, Behzadi P, Cardinal S, Barry H, Neagoe P-E, Juneau M, Nigam A, Sirois**
480 **MG, Gagnon D.** Acute vascular benefits of Finnish sauna bathing in patients with stable
481 coronary artery disease. *Canadian Journal of Cardiology*, EPUB ahead of print, 2020.
482
483 22. **Green DJ, Carter HH, Fitzsimons MG, Cable NT, Thijssen DH, Naylor LH.** Obligatory
484 role of hyperaemia and shear stress in microvascular adaptation to repeated heating in
485 humans. *The Journal of Physiology* 588: 1571–1577, 2010.
486
487 23. **Haque A, Polcyn R, Matzelle D, Banik NL.** New Insights into the Role of Neuron-Specific
488 Enolase in Neuro-Inflammation, Neurodegeneration, and Neuroprotection. *Brain Sciences* 8: 33,
489 2018.
490

- 491 24. **Hawkins BT, Davis TP.** The Blood-Brain Barrier/Neurovascular Unit in Health and
492 Disease. *Pharmacological Reviews* 57: 173–185, 2005.
493
- 494 25. **Jouffroy R, Alves B, Mauvieux B, Mallet L, Beaudoux J-L, Cottart C-H.** NSE S100B
495 protein blood level assessment during a long-distance trail race. *Annales de Biologie Clinique* 77:
496 532–536, 2019.
497
- 498 26. **Kanner AA, Marchi N, Fazio V, Mayberg MR, Koltz MT, Siomin V, Stevens**
499 **GHJ, Masaryk T, Ayumar B, Vogelbaum MA, Barnett GH, Janigro D.** Serum S100B: A
500 Noninvasive Marker of Blood-Brain Barrier Function and Brain Lesions. *Cancer* 97: 2806–2813,
501 2003.
502
- 503 27. **Kihara T, Miyata M, Fukudome T, Ikeda Y, Shinsato T, Kubozono T, Fujita**
504 **S, Kuwahata S, Hamasaki S, Torii H, Lee S, Toda H, Tei C.** Waon therapy improves the
505 prognosis of patients with chronic heart failure. *Journal of Cardiology* 53: 214–218, 2009.
506
- 507 28. **Kiyatkin EA, Sharma HS.** Permeability of the blood–brain barrier depends on brain
508 temperature. *Neuroscience* 161: 929–939, 2009.
509
- 510 29. **Kunutsor SK, Häkkinen A, Zaccardi F, Laukkanen T, Lee E, Willeit P, Khan**
511 **H, Laukkanen JA.** Short-term effects of Finnish sauna bathing on blood-based markers of
512 cardiovascular function in non-naive sauna users. *Heart and Vessels* 33: 1515–1524, 2018.
513
- 514 30. **Koh SXT, Lee JKW.** Erratum to: S100B as a Marker for Brain Damage and Blood–Brain
515 Barrier Disruption Following Exercise. *Sports Medicine* 44: 867–867, 2014.
516
- 517 31. **Koko V.** Effect of acute heat stress on rat adrenal glands: a morphological and stereological
518 study. *Journal of Experimental Biology* 207: 4225–4230, 2004.
519
- 520 32. **Laukkanen T, Khan H, Zaccardi F, Laukkanen JA.** Association Between Sauna Bathing
521 and Fatal Cardiovascular and All-Cause Mortality Events. *JAMA Internal Medicine* 175: 542,
522 2015.
523
- 524 33. **Laukkanen T, Kunutsor S, Kauhanen J, Laukkanen JA.** Sauna bathing is inversely
525 associated with dementia and Alzheimer’s disease in middle-aged Finnish men. *Age and*
526 *Ageing* 46: 245–249, 2016.
527
- 528 34. **Laukkanen T, Kunutsor SK, Zaccardi F, Lee E, Willeit P, Khan H, Laukkanen JA.**
529 Acute effects of sauna bathing on cardiovascular function. *Journal of Human*
530 *Hypertension* 32: 129–138, 2017.
531
- 532 35. **Laukkanen JA, Laukkanen T, Khan H, Babar M, Kunutsor SK.** Combined Effect of
533 Sauna Bathing and Cardiorespiratory Fitness on the Risk of Sudden Cardiac Deaths in Caucasian
534 Men: A Long-term Prospective Cohort Study. *Progress in Cardiovascular Diseases* 60: 635–
535 641, 2018.
536

- 537 36. **Lee E, Laukkanen T, Kunutsor SK, Khan H, Willeit P, Zaccardi F, Laukkanen JA.**
538 Sauna exposure leads to improved arterial compliance: Findings from a non-randomised
539 experimental study. *European Journal of Preventive Cardiology* 25: 130–138, 2017.
540
- 541 37. **Liu M, Zhang C, Liu W, Luo P, Zhang L, Wang Y, Wang Z, Fei Z.** A Novel Rat Model
542 of Blast-Induced Traumatic Brain Injury Simulating Different Damage Degree: Implications for
543 Morphological, Neurological, and Biomarker Changes. *Frontiers in Cellular Neuroscience* 9,
544 2015.
545
- 546 38. **Neselius S, Brisby H, Theodorsson A, Blennow K, Zetterberg H, Marcusson J.** CSF-
547 Biomarkers in Olympic Boxing: Diagnosis and Effects of Repetitive Head Trauma. *PLoS*
548 *ONE* 7, 2012.
549
- 550 39. **Ohori T, Nozawa T, Ihori H, Shida T, Sobajima M, Matsuki A, Yasumura S, Inoue H.**
551 Effect of Repeated Sauna Treatment on Exercise Tolerance and Endothelial Function in Patients
552 with Chronic Heart Failure. *The American Journal of Cardiology* 109: 100–104, 2012.
553
- 554 40. **Olivera A, Lejbman N, Jeromin A, French LM, Kim H-S, Cashion A, Mysliwiec**
555 **V, Diaz-Arrastia R, Gill J.** Peripheral Total Tau in Military Personnel Who Sustain Traumatic
556 Brain Injuries During Deployment. *JAMA Neurology* 72: 1109, 2015.
557
- 558 41. **Path G, Scherbaum WA, Bornstein SR.** The role of interleukin-6 in the human adrenal
559 gland. *European Journal of Clinical Investigation* 30: 91–95, 2000.
560
- 561 42. **Profaci CP, Munji RN, Pulido RS, Daneman R.** The blood–brain barrier in health and
562 disease: Important unanswered questions. *Journal of Experimental Medicine* 217, 2020.
563
- 564 43. **Raven PB, Romero SA.** Increasing body temperature with dynamic exercise and/or by
565 wallowing/bathing in hot water or saunas: Effects on cerebral blood flow. *The Journal of*
566 *Physiology* 598: 1421–1422, 2020.
567
- 568 44. **Rowell LB.** Hyperthermia: a hyperadrenergic state. *Hypertension* 15: 505–507, 1990.
569
- 570 45. **Rubenstein R, Chang B, Yue JK, Chiu A, Winkler EA, Puccio AM, Diaz-Arrastia**
571 **R, Yuh EL, Mukherjee P, Valadka AB, Gordon WA, Okonkwo DO, Davies P, Agarwal**
572 **S, Lin F, Sarkis G, Yadikar H, Yang Z, Manley GT, Wang KKW, Cooper SR, Dams-**
573 **O'Connor K, Borrasso AJ, Inoue T, Maas AIR, Menon DK, Schnyer DM, Vassar MJ.**
574 Comparing Plasma Phospho Tau, Total Tau, and Phospho Tau–Total Tau Ratio as Acute and
575 Chronic Traumatic Brain Injury Biomarkers. *JAMA Neurology* 74: 1063, 2017.
576
- 577 46. **Schmechel D, Marangos PJ, Brightman M.** Neurone-specific enolase is a molecular
578 marker for peripheral and central neuroendocrine cells. *Nature* 276: 834–836, 1978.
579
- 580 47. **Schulpis KH, Moukas M, Parthimos T, Tsakiris T, Parthimos N, Tsakiris S.** The effect
581 of α -Tocopherol supplementation on training-induced elevation of S100B protein in sera of
582 basketball players. *Clinical Biochemistry* 40: 900–906, 2007.

- 583
584 48. **Shahim P, Gren M, Liman V, Andreasson U, Norgren N, Tegner Y, Mattsson**
585 **N, Andreasen N, Öst M, Zetterberg H, Nellgård B, Blennow K.** Serum neurofilament light
586 protein predicts clinical outcome in traumatic brain injury. *Scientific Reports* 6, 2016.
587
588 49. **Shahim P, Tegner Y, Wilson DH, Randall J, Skillbäck T, Pazooki D, Kallberg**
589 **B, Blennow K, Zetterberg H.** Blood Biomarkers for Brain Injury in Concussed Professional Ice
590 Hockey Players. *JAMA Neurology* 71: 684, 2014.
591
592 50. **Sharma HS, Duncan JA, Johanson CE.** Whole-body hyperthermia in the rat disrupts the
593 blood-cerebrospinal fluid barrier and induces brain edema. *Brain Edema XIII Acta*
594 *Neurochirurgica Supplementum* 96: 426–431, 2006.
595
596 51. **Sharma HS, Hoopes PJ.** Hyperthermia induced pathophysiology of the central nervous
597 system. *International Journal of Hyperthermia* 19: 325–354, 2003.
598
599 52. **Sharma HS, Johanson CE.** Blood–cerebrospinal fluid barrier in hyperthermia. *Progress in*
600 *Brain Research Neurobiology of Hyperthermia* 162: 459–478, 2007.
601
602 53. **Shinsato T, Miyata M, Kubozono T, Ikeda Y, Fujita S, Kuwahata S, Akasaki**
603 **Y, Hamasaki S, Fujiwara H, Tei C.** Waon therapy mobilizes CD34 cells and improves
604 peripheral arterial disease. *Journal of Cardiology* 56: 361–366, 2010.
605
606 54. **Sobajima M, Nozawa T, Ihori H, Shida T, Ohori T, Suzuki T, Matsuki A, Yasumura**
607 **S, Inoue H.** Repeated sauna therapy improves myocardial perfusion in patients with chronically
608 occluded coronary artery-related ischemia. *International Journal of Cardiology* 167: 237–243,
609 2013.
610
611 55. **Thomas KN, Rij AMV, Lucas SJE, Cotter JD.** Lower-limb hot-water immersion acutely
612 induces beneficial hemodynamic and cardiovascular responses in peripheral arterial disease and
613 healthy, elderly controls. *American Journal of Physiology-Regulatory, Integrative and*
614 *Comparative Physiology* 312, 2017.
615
616 56. **Thompson HJ, Tkacs NC, Saatman KE, Raghupathi R, Mcintosh TK.** Hyperthermia
617 following traumatic brain injury: a critical evaluation. *Neurobiology of Disease* 12: 163–173,
618 2003.
619
620 57. **Topolovec-Vranic J, Pollmann-Mudryj M-A, Ouchterlony D, Klein D, Spence**
621 **J, Romaschin A, Rhind S, Tien HC, Baker AJ.** The Value of Serum Biomarkers in Prediction
622 Models of Outcome After Mild Traumatic Brain Injury. *The Journal of Trauma: Injury,*
623 *Infection, and Critical Care* 71, 2011.
624
625 58. **Tubaro C, Arcuri C, Giambanco I, Donato R.** S100B protein in myoblasts modulates
626 myogenic differentiation via NF- κ B-dependent inhibition of MyoD expression. *Journal of*
627 *Cellular Physiology* 223: 270–282, 2010.
628

- 629 59. **Wang KK, Yang Z, Zhu T, Shi Y, Rubenstein R, Tyndall JA, Manley GT.** An update on
630 diagnostic and prognostic biomarkers for traumatic brain injury. *Expert Review of Molecular*
631 *Diagnostics* 18: 165–180, 2018.
632
- 633 60. **Watson P, Black KE, Clark SC, Maughan RJ.** Exercise in the Heat. *Medicine & Science*
634 *in Sports & Exercise* 38: 2118–2124, 2006.
635
- 636 61. **Watson P, Head K, Pitiot A, Morris P, Maughan RJ.** Effect of Exercise and Heat-Induced
637 Hypohydration on Brain Volume. *Medicine & Science in Sports & Exercise* 42: 2197–2204,
638 2010.
639
- 640 62. **Watson P, Shirreffs SM, Maughan RJ.** Blood-brain barrier integrity may be threatened by
641 exercise in a warm environment. *American Journal of Physiology-Regulatory, Integrative and*
642 *Comparative Physiology* 288: R1689–1694, 2005.
643
- 644 63. **Woodman RJ; Playford DA; Watts GF; Cheetham C; Reed C; Taylor RR; Puddey**
645 **IB; Beilin LJ; Burke V; Mori TA; Green D; RJ, Playford DA, Watts GF, Cheetham C, Reed**
646 **C, Taylor RR, Puddey IB, Beilin LJ, Burke V, Mori TA, Green D.** Improved analysis of
647 brachial artery ultrasound using a novel edge-detection software system. *Journal of applied*
648 *physiology* 91: 929–937, 2001.
649
- 650 64. **Yang Z, Lin F, Robertson CS, Wang KK.** Dual Vulnerability of TDP-43 to Calpain and
651 Caspase-3 Proteolysis after Neurotoxic Conditions and Traumatic Brain Injury. *Journal of*
652 *Cerebral Blood Flow & Metabolism* 34: 1444–1452, 2014.
653
- 654 65. **Zetterberg H, Hietala MA, Jonsson M, Andreasen N, Styrud E, Karlsson I, Edman**
655 **Å, Popa C, Rasulzada A, Wahlund L-O, Mehta PD, Rosengren L, Blennow K, Wallin A.**
656 **Neurochemical Aftermath of Amateur Boxing.** *Archives of Neurology* 63: 1277, 2006.
657

658 **Figure legend**

659

660 **Figure 1.** Individual values for arterial (gray filled bars) and venous (open bars) S100B (top
661 left), NSE (top right), NF-L (bottom left), and tau protein (bottom right), at normothermic
662 baseline (BL) and hyperthermic heat stress (HS). No significant interaction was observed in any
663 variable. However, there was a significant condition effect ($P=0.028$) of NSE, corresponding to a
664 significant increase in arterial ($P=0.023$) but not venous NSE ($P=0.173$) from BL to HS.

665

666 **Figure 2.** Individual values for cerebral exchange of S100B (top left), NSE (top right), NF-L
667 (bottom left), and tau protein (bottom right), at normothermic baseline (BL) and hyperthermic
668 heat stress (HS). Gray filled bars with error bars denote mean \pm SD. Negative values denote net
669 cerebral release, positive values denote uptake. No significant difference ($P>0.05$) was observed
670 between BL and HS in any measure.

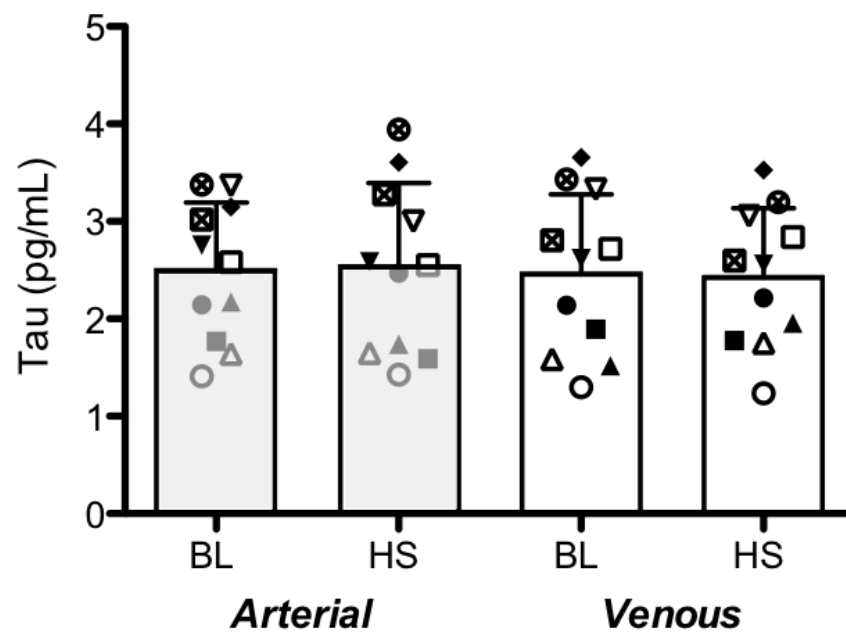
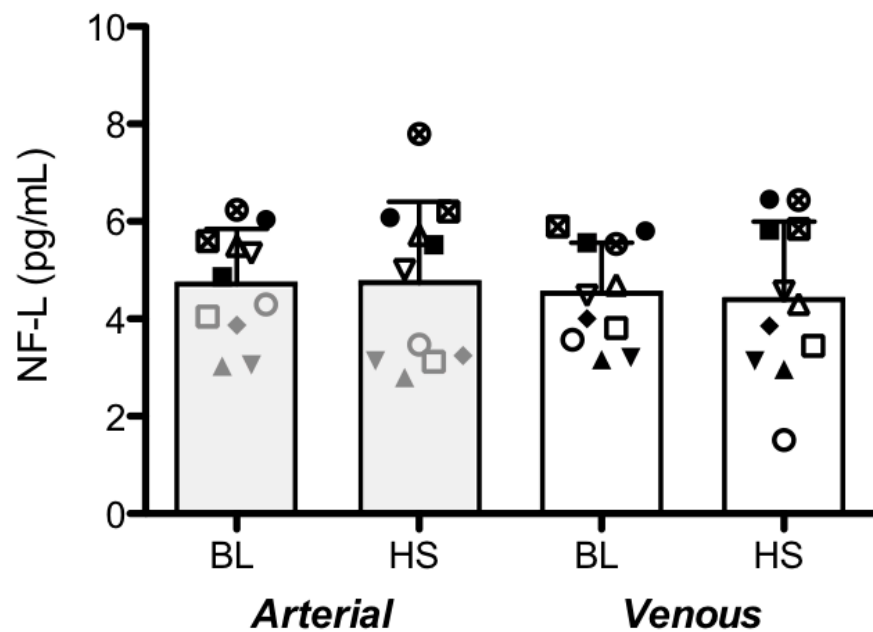
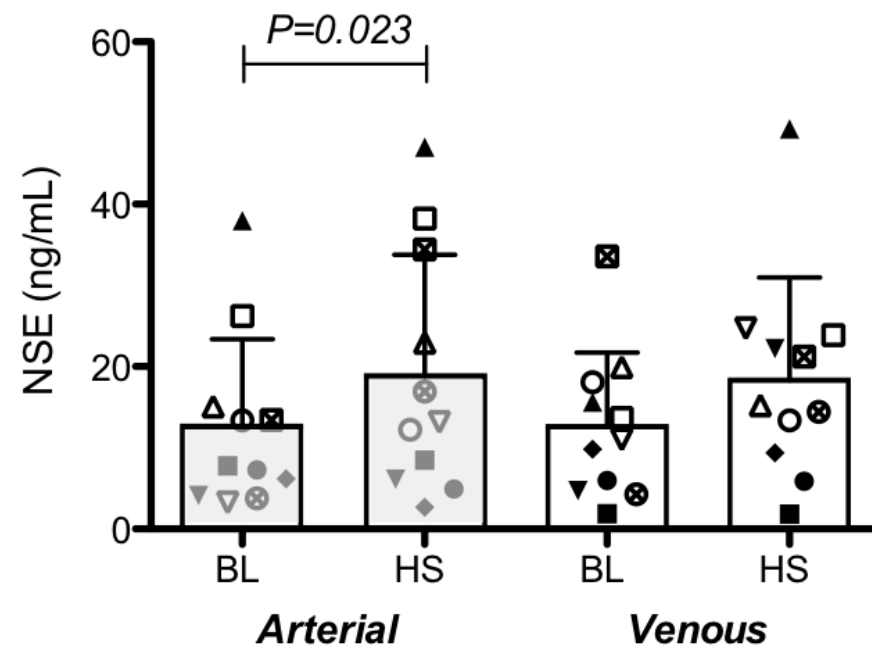
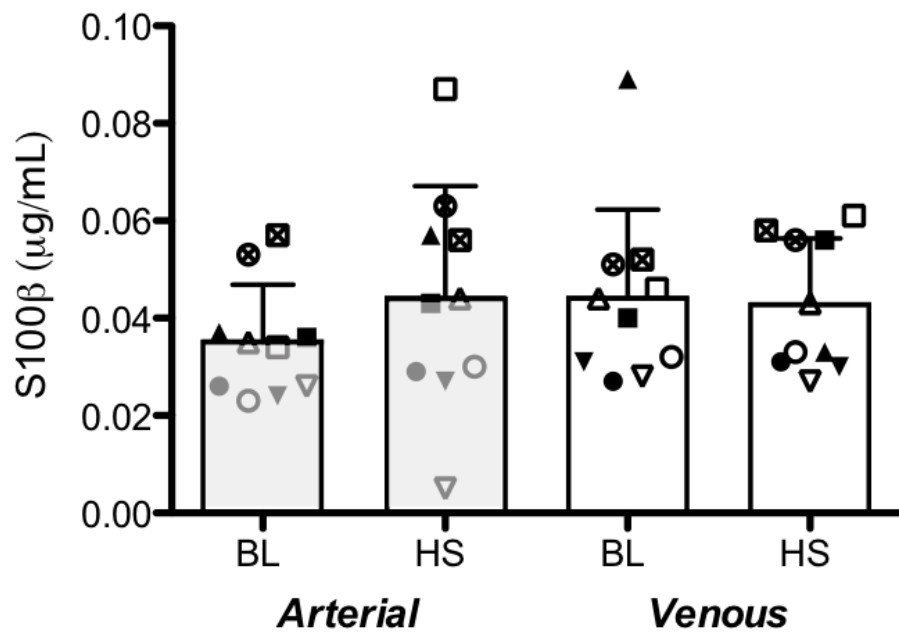

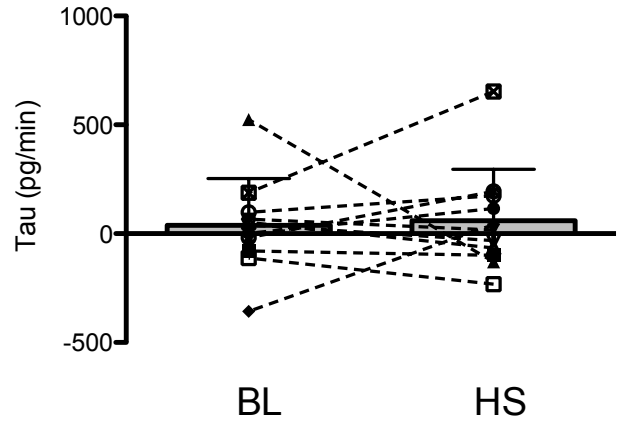
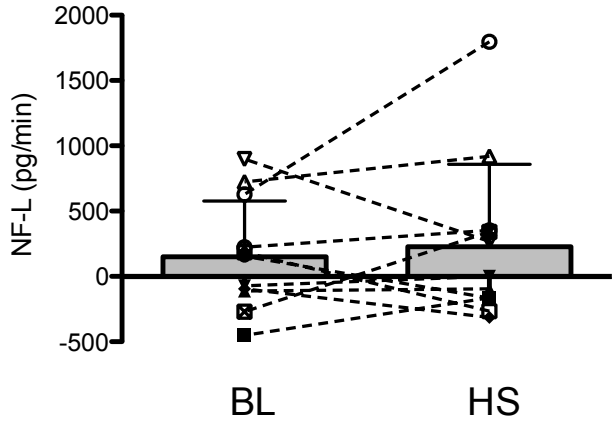
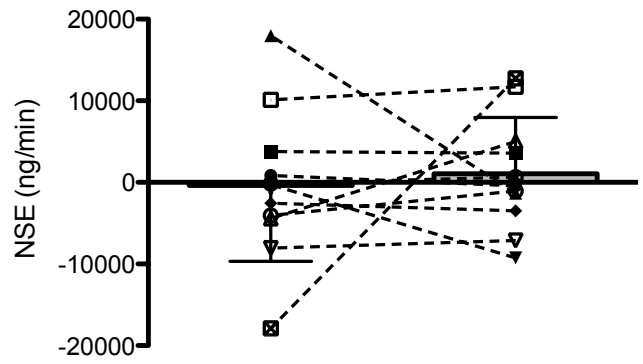
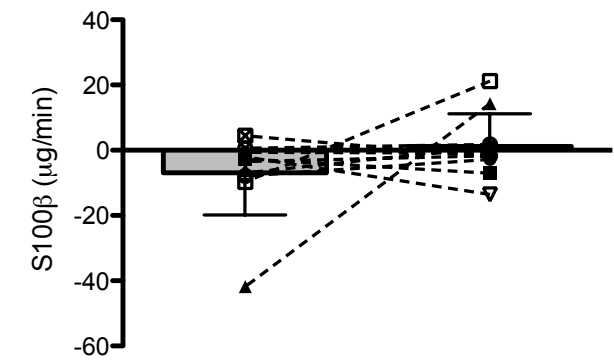

Table 1. Baseline and heat stress participant descriptives. T_{core}; esophageal temperature. MAP; mean arterial blood pressure, intra-radial. CBF; cerebral blood flow (duplex ultrasound of the internal and vertebral carotid artery). HR; heart rate from lead II. The participant symbols are consistent with Figure 1.

Subject Symbol	Baseline				Heat Stress			
	Temp °C	MAP (mmHg)	CBF (ml/min)	HR (BPM)	Temp °C	MAP (mmHg)	CBF (ml/min)	HR (HR)
1 ●	37.5	97	664	74	39.6	79	449	124
2 ☒	37.4	95	887	63	39.5	79	966	134
3 ○	37.4	97	871	48	39.3	88	917	92
4 ▽	37.0	88	1038	69	39.0	86	617	126
5 ▼	37.0	89	494	53	39.2	90	574	114
6 ⊗	37.3	80	618	80	38.9	57	461	144
7 □	37.1	99	807	62	39.2	73	815	100
8 ▲	37.0	95	804	79	39.0	82	596	131
9 ■	37.4	92	646	65	39.1	73	540	112
10 △	37.2	88	906	62	38.8	77	651	114
11 ◆	37.4	78	704	64	39.4	69	517	124
Mean	37.3	91	767	65	39.2	77	646	119
±SD	0.2	7	157	10	0.2	9	177	15

Table 2. Mean values \pm SD of arterial and venous S100B, NSE, tau protein, and NF-L at baseline (normothermia) and heat stress ($+2^{\circ}\text{C}$ esophageal temperature). Net exchange is calculated from the global cerebral blood flow \times the arterial-venous difference. Condition = baseline vs. heat

Condition: Site:	Baseline		Heat stress	
	Arterial	Venous	Arterial	Venous
S100B ($\mu\text{g/mL}$) $n=10$	0.035 ± 0.012	0.044 ± 0.019	0.044 ± 0.024	0.043 ± 0.014
<i>Condition (P = 0.445); Site (P = 0.156); Condition \times Site (P = 0.327)</i>				
<i>a-v_D ($\mu\text{g/mL}$)</i>	-0.009 ± 0.017		0.001 ± 0.016	
<i>Net exchange ($\mu\text{g/min}$)</i>	-7.003 ± 13.715		1.050 ± 10.583	
NSE (ng/mL) $n=11$	12.6 ± 10.8	12.6 ± 9.1	18.8 ± 15.0	18.3 ± 12.7
<i>Condition (P = 0.028); Site (P = 0.910); Condition \times Site (P = 0.908)</i>				
<i>a-v_D (ng/mL)</i>	-0.007 ± 11.0		0.52 ± 9.7	
<i>Net exchange (ng/min)</i>	-422.5 ± 9301.8		1006.3 ± 6913.9	
Tau (pg/mL) $n=11$	2.5 ± 0.7	2.5 ± 0.8	2.5 ± 0.9	2.4 ± 0.9
<i>Condition (P = 0.877); Site (P = 0.315); Condition \times Site (P = 0.626)</i>				
<i>a-v_D (pg/mL)</i>	0.04 ± 0.3		0.1 ± 0.3	
<i>Net exchange (pg/min)</i>	36.8 ± 214.8		58 ± 236.7	
NF-L (pg/mL) $n=11$	4.7 ± 1.1	4.5 ± 1.0	4.7 ± 1.7	4.4 ± 1.6
<i>Condition (P = 0.800); Site (P = 0.198); Condition \times Site (P = 0.447)</i>				
<i>a-v_D (pg/mL)</i>	0.2 ± 0.5		0.3 ± 0.9	
<i>Net exchange (pg/min)</i>	165.2 ± 428.5		243.3 ± 630.0	

stress; Site = arterial vs. venous; Condition \times Site = interaction.