

SOME FACTORS AFFECTING NERVE
CONDUCTION

ROBERT FERN

JULY 1992

A THESIS SUBMITTED TO THE UNIVERSITY OF LONDON
FOR THE DEGREE OF DOCTOR OF PHILOSOPHY

Department of Physiology
University College London

ProQuest Number: 10629567

All rights reserved

INFORMATION TO ALL USERS

The quality of this reproduction is dependent upon the quality of the copy submitted.

In the unlikely event that the author did not send a complete manuscript and there are missing pages, these will be noted. Also, if material had to be removed, a note will indicate the deletion.



ProQuest 10629567

Published by ProQuest LLC (2017). Copyright of the Dissertation is held by the Author.

All rights reserved.

This work is protected against unauthorized copying under Title 17, United States Code
Microform Edition © ProQuest LLC.

ProQuest LLC.
789 East Eisenhower Parkway
P.O. Box 1346
Ann Arbor, MI 48106 – 1346

ABSTRACT

In the past compound action potential recording has been widely employed to investigate patterns of nerve conduction block. This technique, however, has a number of methodological drawbacks which do not apply to the unitary action potential recording technique. In this thesis unitary potentials have been recording during a number of types of nerve block to gain a better understanding of the underlying events.

It was found that 250 mmHg of pressure applied to the isolated frog nerve generated a differential block of fast myelinated axons as a result of nerve fibre deformation. However, nerve ischaemia (studied in the cat sciatic nerve) was found to have the opposite effect, generating a differential block of slow axons. Conduction block induced by compression *in vivo* was found to have a similar pattern to that induced by ischaemia when of the order associated with the clinically prevalent carpal tunnel syndrome. More extreme compression however, of the order associated with clinically acute compression lesions, was found to differentially affect fast axons, suggesting that block is due to physical trauma under these conditions.

Experiments were also performed to evaluate how the structure-function relationship of the frog myelinated axon influences the axons' response to changes in ionic environment. It was found that perfusion of frog myelinated axons with a high potassium concentration induced slowing in action potential conduction velocity over a biphasic time course, apparently due to potassium diffusing into both the perinodal and the periaxonal compartments. Potassium diffusion into the periaxonal space was found to have profound effects upon nerve conduction, while the slow evolution of these effects indicates effective potassium ion homeostasis beneath the myelin sheath.

In contrast to high potassium perfusion, low sodium perfusion produced simple monotonic changes in conduction velocity, affecting the slowest group of axons to the greater extent. This confirms an earlier theoretical prediction that small myelinated axons have a low safety factor and may explain the differential action of local anaesthetics. An assessment was also made of the use of compound action potential recording as a technique to investigate changes in nerve conduction. This showed that compound action potentials are a valuable tool for evaluating qualitative changes in nerve conduction, but are not appropriate for demonstrating the specific block of a group of axons.

ACKNOWLEDGEMENTS

I would like to thank all those who have helped me perform the work detailed in this thesis.

For their help and support during my course of study I would like to thank Professor John Stephens, Professor Roger Woledge, Dr Malcolm Segal and Dr Bruce Lynn.

In particular I wish to thank my friend and supervisor Dr Philip Harrison.

I also wish to thank the many friends who have helped to make my stay at University College so enjoyable.

Finally I must thank my parents for their encouragement, their support and their love.

I would on first setting out,
inform the reader that there
is a much greater number
of miracles and natural secrets
in the frog than anyone ever
before thought of or discovered.

Jan Swammerdam (1637-1680)

It may be said that wherever frogs
were to be found, and where two kinds
of metal could be procured, everyone
was anxious to see the mangled limbs
of frogs brought to life...

Emil Du Bois Raymond (1818-1896)

CONTENTS

| | PAGE |
|--|------|
| TITLE PAGE..... | 1 |
| ABSTRACT..... | 2 |
| ACKNOWLEDGEMENTS..... | 3 |
| CONTENTS..... | 5 |
| LIST OF FIGURES..... | 10 |
| LIST OF TABLES..... | 13 |
| LIST OF ABBREVIATIONS..... | 14 |
| | |
| <u>CHAPTER 1</u> INTRODUCTION..... | 15 |
| 1. a. HISTORICAL PERSPECTIVE..... | 16 |
| 1. b. GENERAL INTRODUCTION..... | 21 |
| | |
| <u>CHAPTER 2</u> METHODS..... | 24 |
| 2. a. INTRODUCTION..... | 25 |
| 2. b. FROG EXPERIMENTS..... | 25 |
| 2. b. 1. Ringer solutions..... | 25 |
| 2. b. 2. Sciatic nerve dissection..... | 25 |
| 2. b. 3. Stimulation and recording..... | 27 |
| 2. b. 4. Distribution of conduction velocities..... | 29 |
| 2. b. 5. Methods for nerve perfusion..... | 29 |
| 2. b. 6. Controls..... | 31 |
| 2. b. 7. Methods for nerve compression..... | 31 |
| 2. b. 8. Compound action potential experiments..... | 33 |
| 2. c. CAT EXPERIMENTS..... | 35 |
| 2. c. 1. Solutions..... | 35 |
| 2. c. 2. Initial experimental procedures... | 35 |
| 2. c. 3. Peripheral nerve and spinal cord dissection..... | 36 |
| 2. c. 4. Experimental set up..... | 37 |
| 2. c. 5. Recording..... | 37 |
| 2. c. 6. Distribution of conduction velocities..... | 38 |
| 2. c. 7. Stimulation..... | 38 |

PAGE

| | |
|---|----|
| 2. c. 8. Recording routine..... | 41 |
| 2. c. 9. Methods for nerve ischaemia..... | 41 |
| 2. c. 10. Methods for nerve compression.... | 43 |

RESULTS AND DISCUSSION I: THE RELATIVE IMPORTANCE OF NERVE DEFORMATION AND NERVE ISCHAEMIA IN THE CONDUCTION BLOCK PRODUCED BY NERVE COMPRESSION.

| | |
|--------------------------------|----|
| INTRODUCTION TO SECTION I..... | 47 |
| HISTORICAL BACKGROUND..... | 49 |

CHAPTER 3 THE PATTERN OF CONDUCTION BLOCK INDUCED BY NERVE COMPRESSION AND ATTRIBUTED TO DEFORMATION.

| | |
|--|----|
| 3. a. INTRODUCTION..... | 55 |
| 3. b. RESULTS..... | 56 |
| 3. b. 1. 250 mmHg pressure..... | 56 |
| 3. b. 2. 750 mmHg pressure..... | 61 |
| 3. b. 3. Rate of conduction block..... | 61 |
| 3. b. 4. Anoxia over the compressed region. | 61 |
| 3. b. 5. Compound action potential experiments..... | 65 |
| 3. c. DISCUSSION..... | 68 |
| 3. c. 1. Mechanisms of conduction block at different degrees of compression.. | 68 |
| 3. c. 2. Scatter in the order of conduction block..... | 70 |
| 3. c. 3. Comparison with previous findings. | 71 |
| 3. c. 4. Relevance of current findings..... | 72 |

CHAPTER 4 THE EFFECT OF ISCHEMIA UPON NERVE CONDUCTION.

| | |
|---|----|
| 4. a. INTRODUCTION..... | 75 |
| 4. b. RESULTS..... | 76 |
| 4. b. 1. Dedicated experiments..... | 77 |
| 4. b. 2. Non-dedicated experiments..... | 80 |
| 4. c. DISCUSSION..... | 84 |

| | PAGE |
|---|------|
| 4. c. 1. The global ischaemia model..... | 84 |
| 4. c. 2. Ischaemia in clinical conditions.. | 86 |
| 4. c. 3. Possible mechanisms underlying the pattern of conduction block during ischaemia..... | 87 |
| 4. c. 4. Ischaemia as an experimental tool. | 87 |

CHAPTER 5 THE CONTRIBUTION OF ISCHAEMIA AND DEFORMATION TO
CONDUCTION BLOCK GENERATED BY COMPRESSION OF NERVE *IN VIVO*.

| | |
|--|-----|
| 5. a. INTRODUCTION..... | 90 |
| 5. b. RESULTS..... | 91 |
| 5. c. DISCUSSION..... | 98 |
| 5. c. 1. Scatter in the order of conduction block..... | 98 |
| 5. c. 2. Basis of conduction block under mild and severe compression..... | 99 |
| 5. c. 3. Relevance to clinical compression disorders..... | 99 |
| 5. c. 4. A note on tourniquet palsy..... | 101 |

CONCLUSIONS TO SECTION I..... 104

RESULTS AND DISCUSSION II: CONDUCTION BLOCK IN FROG
MYELINATED AXONS.

| | |
|---------------------------------|-----|
| INTRODUCTION TO SECTION II..... | 106 |
| HISTORICAL BACKGROUND..... | 107 |

CHAPTER 6 THE EFFECTS OF HIGH EXTRACELLULAR POTASSIUM UPON
NERVE CONDUCTION.

| | |
|--|-----|
| 6. a. INTRODUCTION..... | 112 |
| 6. b. RESULTS..... | 113 |
| 6. b. 1. High potassium perfusion..... | 113 |

| | PAGE |
|--|------|
| 6. b. 2. Effect of TEA..... | 118 |
| 6. b. 3. Effects of extended TEA perfusion. | 127 |
| 6. b. 4. Spontaneous activity following prolonged TEA perfusion..... | 127 |
| 6. b. 5. High calcium Ringer and low sodium Ringer perfusion..... | 127 |
| 6. b. 6. Effects of high potassium when [K]*[Cl] is constant..... | 130 |
| 6. b. 7. Analysis of any differential effects..... | 133 |
| 6. c. DISCUSSION..... | 133 |
| 6. c. 1. Depolarisation due to high potassium..... | 134 |
| 6. c. 2. Slow changes in conduction velocity cannot be accounted for by any known effect at the nodal axolemma..... | 138 |
| 6. c. 3. Possible double site of action of high potassium solutions..... | 140 |
| 6. c. 4. Initial step fall in velocity..... | 140 |
| 6. c. 5. Slow drift in velocity - a second site of action for potassium..... | 141 |
| 6. c. 6. Slow time course of action at second site, compared to recovery..... | 142 |
| 6. c. 7. The effect of TEA..... | 143 |
| 6. c. 8. Spontaneous discharge in TEA..... | 144 |
| 6. c. 9. Effects of high calcium and low sodium solutions..... | 145 |
| 6. c. 10. Lack of differential effects..... | 146 |
| 6. c. 11. Are slow changes in conduction velocity important during pathological and physiological high potassium..... | 146 |

CHAPTER 7 THE EFFECTS OF LOW SODIUM PERFUSION UPON NERVE
CONDUCTION.

| | |
|-------------------------|-----|
| 7. a. INTRODUCTION..... | 150 |
|-------------------------|-----|

| | PAGE |
|--|---------|
| 7. b. RESULTS..... | 150 |
| 7. c. DISCUSSION..... | 156 |
| 7. c. 1. Low sodium perfusion is a good method of investigating safety factor..... | 157 |
| 7. c. 2. The results agree with a theoretical account..... | 158 |
| 7. c. 3. Relevance of current findings..... | 158 |
| <u>CHAPTER 8</u> CHANGES IN COMPOUND ACTION POTENTIAL SHAPE DURING NERVE CONDUCTION BLOCK. | |
| 8. a. INTRODUCTION..... | 160 |
| 8. b. RESULTS..... | 161 |
| 8. c. DISCUSSION..... | 165 |
| CONCLUSION TO SECTION II..... | 169 |
| <u>APPENDIX I</u> SUMMARY OF IONIC CHANNEL DISTRIBUTION IN THE FROG MYELINATED AXON AND COMPARISON TO THE MAMMALIAN MYELINATED AXON..... | |
| | 171 |
| REFERENCES..... | 174 |

LIST OF FIGURES

| | PAGE |
|--|-------|
| Figure 1. Circuit diagram of a pulse generator..... | 28 |
| Figure 2. The distribution of nerve fibre conduction velocities in the frog sciatic nerve..... | 30 |
| Figure 3.) Experimental arrangements for frog nerve Figure 4.) experiments..... | 32-34 |
| Figure 5. The distribution of conduction velocities in the cat sciatic nerve..... | 39-40 |
| Figure 6. Experimental arrangement for cat nerve ischaemia experiments..... | 42 |
| Figure 7. Record of fall of blood pressure in cat nerve ischaemia experiments..... | 44 |
| Figure 8. Experimental arrangement for cat nerve compression experiments..... | 45 |
| Figure 9. Conduction block of action potentials during 250 mmHg pressure, including plot of data..... | 57 |
| Figure 10. Plot of the slopes of linear regression analysis for individual nerves plus plot of survival time against initial conduction velocity for 250 mmHg pressure experiments..... | 59-60 |
| Figure 11. Plot of the slopes of linear regression analysis for individual nerves plus plot of survival time against initial conduction velocity for 750 mmHg pressure experiments..... | 62 |
| Figure 12. Plot of survival time under 750 mmHg pressure against initial conduction velocity..... | 63-64 |

PAGE

| | |
|---|-------|
| Figure 13. Plot of survival time under 20 mmHg pressure against initial conduction velocity..... | 66 |
| Figure 14. Changes in compound action potentials produced by high and low compression..... | 67 |
| Figure 15. Action potentials recorded from the cat before and after cardiac arrest..... | 78 |
| Figure 16. Plots of survival time following cardiac arrest against initial conduction velocity..... | 79 |
| Figure 17. Plot of survival time against initial conduction velocity for sensory axons..... | 81 |
| Figure 18. Plot of survival time against initial conduction velocity for motor axons..... | 82 |
| Figure 19. Plots of survival time against initial conduction velocity for sensory and motor axons..... | 83 |
| Figure 20. Action potentials recorded from the cat during 70 mmHg pressure, plus data plot..... | 92 |
| Figure 21. Plot of survival time under 70 mmHg against initial conduction velocity..... | 93 |
| Figure 22. Plot of the slopes of linear regression analysis for individual nerves plus plot of survival time against initial conduction velocity for 250 mmHg pressure experiments..... | 95-96 |
| Figure 23. Histogram of the correlation coefficients of data collected from individual nerves..... | 97 |

| | |
|---|---------|
| Figure 24. Comparison of the effects of deformation, ischaemia, 70 mmHg pressure and 250 mmHg pressure.... | 100 |
| Figure 25. Action potentials recorded from the frog sciatic nerve during high potassium perfusion..... | 115-116 |
| Figure 26. Plot of conduction velocity from the data shown in Figure 25..... | 117 |
| Figure 27a.) Action potential recorded during high potassium perfusion, illustrating the effects of 5mM TEA..... | 119-122 |
| Figure 27b.) | |
| Figure 27c.) | |
| Figure 28. Changes in conduction velocity calculated from the data shown in Figures 27 a, b, c..... | 124 |
| Figure 29. Changes in conduction velocity of an action potential recorded during high potassium perfusion..... | 125 |
| Figure 30. Changes in conduction velocity in the same action potential in Figure 29 but including the effects of 5 mM TEA..... | 126 |
| Figure 31. Changes in conduction velocity during high Potassium perfusion following a prolonged period of 5 mM TEA perfusion..... | 128 |
| Figure 32. Spontaneous activity following prolonged 5 mM TEA perfusion..... | 129 |
| Figure 33. Changes in conduction velocity during low sodium and high calcium perfusion..... | 131 |

PAGE

| | |
|---|---------|
| Figure 34. Changes in conduction velocity during high potassium perfusion, where $[K]^*[Cl]$ is constant.. | 132 |
| Figure 35. Plot of survival time in high potassium against initial conduction velocity..... | 135 |
| Figure 36. Plot of survival time in high potassium (during TEA perfusion) against initial conduction velocity..... | 136 |
| Figure 37. Action potential recorded during low sodium perfusion..... | 151 |
| Figure 38. Changes in conduction velocity during Low sodium perfusion..... | 152 |
| Figure 39. Plot of average fall in conduction velocity during low sodium perfusion against initial conduction velocity, in decades..... | 154 |
| Figure 40. Histogram of conduction velocity of axons which block in, or survive, low sodium perfusion..... | 155 |
| Figure 41. Changes in compound action potentials produced by high and low compression..... | 162-163 |
| Figure 42. Plot of changes in compound action potentials during cooling, procaine perfusion and low compression..... | 164 |

LIST OF TABLES

| | |
|---|-----|
| TABLE 1. Composition of solutions..... | 26 |
| TABLE 2. Summary of results from chapter 6..... | 134 |
| TABLE 3. Ion channels in frog myelinated axons..... | 172 |

ABBREVIATIONS

CNS: Central nervous system
CP: Common peroneal nerve
Em: Membrane potential
emf: Electromotive force
 E_x : Reversal potential of ion species x
F: Faraday constant
FDL: Flexor digitorum longus nerve
 G_{KF1} : Type 1 fast potassium conductance
 G_{KF2} : Type 2 fast potassium conductance
 G_{Ks} : Slow potassium conductance
 G_{Na} : Sodium conductance
 I_{Na} : Sodium current
 $[X]_o$: Extracellular concentration of ion species X
 $[X]_i$: Intracellular concentration of ion species X
IR: Inward rectifier ionic conductance
MG: Medial gastrocnemius nerve
mmHg: Millimetres of Mercury
m/sec: Metres per second
P: Probability of Correlation
PLA: Plantaris nerve
R: Gas constant
r: Correlation coefficient
SE: Standard error
SUR: Sural nerve
T: Absolute temperature
TEA: Tetraethylammonium Chloride
TIB: Tibial nerve
 θ : Conduction velocity
4-AP: 4-aminopyridine
Psi: Pounds per square inch
LED: Light emitting diode

CHAPTER 1

INTRODUCTION

1. a. HISTORICAL PERSPECTIVE

The early history of neurophysiology is inexorably bound up with early experiments in electro-physics (Gilbert, 1965; Tasaki, 1968, 1982; Aidley, 1978; Burke, 1978; Brazier, 1984, 1988). Thus, the invention by Hawksbee in 1706 of an "influence machine" capable of generating static electricity, and Musschenbroek's Leyden jar (popularised by Nollet, 1746), which stored electric charge, allowed the study of "life force" (ie. animal electricity) to develop. The effects of the electricity produced by these devices captivated the eighteenth century Europeans. Itinerate professors of electricity could be found travelling from town to town amazing people with demonstrations of "life force", the purportedly fluid element which caused limbs to jerk and stimulated the senses of the skin (Burke, 1978). Nollet himself, who had the flair of a natural showman, orchestrated spectacular demonstrations of electricity. On one famous occasion he lined up 180 soldiers hand in hand in the gallery at Versailles before the King of France. When the man at each end of the line touched one pole of a Leyden jar, all of the soldiers jumped into the air simultaneously (Brazier, 1984).

In England the belief that infertility was a result of a lack of "life force" encouraged the electrocution of childless couples at the height of their passions in a "Celestial Magnético-Electrico Bed". Electric shocks became a popular form of treatment for all forms of disease and it was even suggested that electrocution could alleviate the misery of the poor (Burke, 1978).

Although it was clearly a belief of the time that electricity was important in physiology, it was not until Galvani's experiments (Galvani, 1791) that real evidence for animal electricity was produced. Galvani caused the muscles of the frog hind limb to contract simply by applying an electrical potential to the sciatic nerve. Although Galvani misinterpreted many of his experiments, and came into bitter conflict with Volta, it is to Galvani that we look to find the first clear demonstration that nervous activity is associated with electrical changes.

Volta did not believe in animal electricity and attempted to interpret Galvani's results in terms of a theory of bi-metallic currents. He argued that electricity resulted when two different metals were connected via a conducting material, which in the case of Galvani's experiments must be the frog muscle (Volta, 1792). Volta thus claimed that electricity was not generated by the animal tissue itself, but by an external source.

However, the bi-metallic current theory of the frog muscle twitch was called into doubt as muscle contractions could be produced by a single metal (mercury) without a second metal being present (Aldini, 1794).

Humboldt (1797) repeated Galvani's and Volta's experiments and concluded that Galvani had discovered two genuine phenomena: bimetallic electricity and animal electricity, which Humboldt believed were not mutually exclusive (Brazier, 1984). Reviewing the Galvani-Volta feud from this long perspective it is difficult to understand why Humboldt's interpretation of the data did not reconcile the two great scientist, however the two men continued a bitter conflict for many years.

The development of new instruments, in many cases by physiologists themselves, contributed greatly to the expansion in understanding of nerve conduction during the nineteenth and twentieth centuries. Thus, in the second quarter of the nineteenth century Nobili and then Matteucci demonstrated the presence of an injury potential in muscle using the astatic galvanometer developed by Nobili (see Brazier, 1988). It was soon after this that Emil Du Bois Raymond used a new, more sensitive, galvanometer to observe a transient negative current in a frog sciatic nerve and became the first man to observe an action potential (Du Bois Raymond, 1848).

In 1850 Herman Von Helmholtz measured the speed at which the action potential conducted along the frog sciatic nerve, disproving Müller's theory that action potentials were an "imponderable psychical principle" and thus, immeasurable (Von Helmholtz, 1850). Helmholtz extended his results with the important observation that conduction velocity was dependant upon temperature and was thus clearly a biological processes.

In 1889 Nernst derived his famous equation relating the potential difference across a membrane to the concentration of ions on either side of it. At a similar date Ostwald (1890) proposed that bioelectric potentials might arise as a result of the semipermeable nature of the muscle and nerve membranes (See Tasaki, 1982). This work encouraged Bernstein to explain the nerve membrane and action potentials in terms of ion concentration differences across living cell membranes (Bernstein 1902, 1912; see Brazier, 1988). In particular Bernstein believed that the membrane potential was due to the unequal distribution of potassium ions across the membrane and that collapse of this potential due to a change in membrane permeability produced the action potential. This view was not seriously challenged until it was found that the action

potential over-shoots zero potential (Hodgkin and Huxley, 1945).

In his research Bernstein stated the commonly held belief of the time that the site of the membrane potential and of nervous conduction was not the cell membrane. Rather it was thought that the membrane of nerve fibrils within the axon was the functional site of the action potential. Despite this, with Bernstein the understanding of action potentials in nerve fibres was approaching its current form. Improved histology soon dispelled the nerve fibril theory and the membrane potential thus moved to the cell surface.

In the 1920's the invention of valve amplifiers revolutionised electrophysiology. Gasser and Erlanger (Erlanger and Gasser, 1924; Gasser and Erlanger, 1927) used the new technology to record the true shape of the toad sciatic nerve compound action potential. They described a multi-phasic wave form which they explained in terms of a cumulative potential resulting from activity in many nerve fibres. Analyzing this compound action potential Gasser and Erlanger divided axons into various groups according to their conduction velocities. They proposed that these different groups of nerve fibres had different functional roles within the body.

That the different groups of nerve fibres conducted action potentials at different rates indicated a fundamental variation between different classes of fibres. Gasser and Erlanger (1927) correlated the variations in conduction velocity with variations in nerve fibre diameter, managing to mathematically reconstruct the compound action potential by taking into account the distribution of nerve fibre diameters in the nerve. The relationship between conduction velocity and diameter was later confirmed by Hursh in cat nerve fibres (1939).

At about the same time as Gasser and Erlanger were working out how large numbers of nerve fibres transmit action potentials in nerve trunks, Adrian and co-workers began to record from single nerve fibres while stimulating single receptors (Adrian and Zotterman, 1926). It was found that sensory information from the periphery is transmitted to the CNS in a rate coded form. Thus, when a muscle receptor was stretched the nerve fibre connected to the receptor discharged action potentials at a rate that corresponded to the degree of stretch.

In the late 1930's it became possible to measure the potential difference across the nerve membrane, following the discovery by J.Z. Young (1936) of the cephalopod

giant axon. These giant axons can reach diameters of up to $500\text{-}1000\mu$, permitting the introduction of electrodes into the axon interior (Hodgkin and Huxley, 1939, 1945; Curtis and Cole, 1942).

Using this preparation Cole and Curtis (1939) demonstrated the impedance changes which accompany the action potential in the giant axon. Impedance is dependant upon both resistance and capacitance and using a bridge balance technique it was found that while membrane capacitance changed only slightly during the action potential membrane resistance fell by some 97.5%, ie. a transient increase in membrane conductance occurs during the action potential.

In 1949 Hodgkin and Katz demonstrated that the amplitude of the giant axon action potential is dependant upon the extracellular sodium ion concentration. Thus, reducing the number of sodium ions outside the nerve resulted in a corresponding reduction in the height of the action potential. From this observation Hodgkin and Katz proposed the "sodium theory" of the action potential, where a transient increase in sodium ion permeability generates an inflection in membrane potential away from the potassium reversal potential. Unlike previous models of the action potential this accounted for the overshoot of the action potential past the zero potential point.

The various experiments on giant axons came to their zenith with the application of the voltage and space clamp techniques in the early 1950's which yielded specific solutions to the membrane conductance changes which underlie the action potential (Hodgkin, Huxley and Katz, 1952; Hodgkin and Huxley, 1952 a, b, c, d). A rapid increase in the membrane's permeability to sodium ions was found to follow membrane depolarisation, driving the membrane potential towards the sodium reversal potential and accounting for the rising phase of the action potential. This rapidly activating sodium conductance soon inactivates, which together with the activation of a late potassium conductance, returns the membrane potential to the resting level.

Hodgkin and Huxley derived specific equations to describe these time and voltage dependant conductance changes which were then used to simulate the action potential with a remarkable degree of accuracy (Hodgkin and Huxley, 1952 d). Similar analyses have since been applied to a variety of excitable cells with similar success, in particular, in the frog myelinated axon (Frankenhaeuser and Huxley, 1964; Frankenhaeuser, 1964).

Despite the great similarity in the events underlying the action potentials of cephalopod giant axons and frog myelinated axons it is clear that major morphological differences distinguish the two structures. These differences are so great that the way in which the action potential is propagated is fundamentally dissimilar in the two types of axon. Thus, while action potentials are conducted in a continuous manner in non-myelinated axons, in myelinated axons the action potential jumps from one node of Ranvier to the next (Tasaki and Takeuchi, 1942; Huxley and Stämpfli, 1949).

The discovery of saltatory conduction and the quantitative description of the ionic conductances that underlie the action potential can probably be considered as two of the last great discoveries in the classical age of nerve biophysics. Despite this, advances are continually being made in the understanding of nerve conduction. For example, within the last ten years a new level of complexity has been revealed in the myelinated axon. Thus, a variety of ion channel types have been found which have a highly regulated organisation, a new current pathway has been discovered, and the subtleties of axon-glia interactions are only now coming to light.

1. b. GENERAL INTRODUCTION

In the past the study of patterns of nerve conduction failure has been largely dominated by the compound action potential recording technique. Only three main studies have applied the alternative technique of recording unitary action potentials (Paintal 1965; Franz and Iggo 1968; Franz and Perry 1973), while the use of compound action potentials for this purpose continues in recent publications (eg. Dahlin *et al.*, 1989.). This is despite widely acknowledged concerns regarding the use of compound action potential recording in this kind of study (Paintal, 1965, see chapter 8).

In this thesis nerve conduction failure has been characterised by recording unitary action potentials. Unitary action potentials are extracellular recordings of single potentials and correspond to activity in single nerve fibres. Unitary potentials can be monitored during the conduction slowing which always tends to precede conduction failure and which can in itself produce complex changes in compound action potentials. This technique was used in order to obtain a more detailed investigation of the patterns of conduction block induced by a number of conditions.

The body of work contained in this thesis falls into two parts. The first section describes three series of experiments which aim to evaluate and characterise the role played by nerve deformation and nerve ischaemia in the conduction block found in compression neuropathies of peripheral nerves.

In Chapter 3 it is proposed that compression of the isolated frog nerve provides a model of relatively "pure" nerve deformation. Previous studies of deformation have been based upon histological analysis of nerves compressed *in vivo*. Although such studies have proved fruitful, they have the drawback that the structural changes observed might be in part due to nerve ischaemia. As the isolated frog nerve is known to be resistant to anoxia, and will not become ischaemic under the present experimental conditions, compression must be largely restricted to the effects of deformation alone.

Using this preparation it was found that any but the most severe degree of deformation generated a progressive conduction block characterised by the differential susceptibility of the fast conducting axons. However, very severe deformation tended to have the reverse action, differentially affecting slow axons. In both cases the differential effects of deformation were accompanied by an extensive degree of scatter.

differential effects of deformation were accompanied by an extensive degree of scatter. It is argued that this is in large part due to the structure of the frog sciatic nerve trunk.

In Chapter 4 the effects of ischaemia upon nerve conduction are studied. An ischaemia model based on circulatory failure was selected. Thus, in cats in which various sciatic nerve branches had been exposed to allow stimulation, and nerve roots exposed for recording, rapid cardiac arrest was induced. Cardiac arrest will stop the circulation throughout the body and can thus be considered as global ischaemia, effecting the axons being studied without disturbing them in any additional way.

Ischaemia was found to differentially affect the slow conducting myelinated axons, rather than the fast axons. No significant differences were found between sensory and motor axons. The results are consistent with a model of ischaemic conduction block involving the build up of potassium ions under the myelin sheath.

In Chapter 5 an *in vivo* model is employed to study the effects of nerve compression. The contrasting effects of nerve deformation and nerve ischaemia, as described in chapters 3 and 4, are used to interpret the results. Thus, a pressure corresponding to 70 mmHg applied to the nerve (a degree of pressure associated with clinically observed chronic nerve compression lesions) was found to generate conduction block with the slow myelinated axons failing before the fast, with little scatter in the relationship. This was the same pattern found during ischaemia and the opposite to that found during deformation. Application of a higher degree of compression, corresponding to a pressure of 250 mmHg, induced conduction block with the fast myelinated axons failing first, with a great deal of scatter in the relationship. This is a similar result to that obtained with nerve deformation and opposite to that found with ischaemia.

It is concluded that compression *in vivo* can produce conduction block via both ischaemia and nerve deformation and that it is the degree of compression which determines which factor is dominant. As different forms of compression neuropathy involve different degrees of compression it is suggested that they have distinct aetiologies, a fact that may have implications for patient care.

In the second section of this thesis the response of frog myelinated axons to changes in ionic environment are investigated and correlated with recent advances in the understanding of the myelinated axon structure-function relationship. In addition,

an analysis was performed to assess whether compound action potential recordings are appropriate as a technique for evaluating differential block of a specific group of axons.

In Chapter 6 axons are perfused with 12 mM potassium Ringer, which produces conduction block in the great majority of axons. Prior to conduction failure, however, conduction velocity fell with a diphasic time course, provided failure did not occur before the second phase of slowing could be observed. Many of the axons survived high potassium perfusion for periods between 10-140 minutes, yet on no occasion was a plateau level of conduction velocity reached. The rapid phase of slowing could be attenuated by tetraethylammonium (TEA), which had no apparent effect upon the slow phase of slowing. These characteristics are consistent with the view that potassium ions diffuse quickly into the perinodal space resulting in rapid conduction slowing, followed by a slow accumulation of potassium within the periaxonal space beneath the myelin.

In contrast to high potassium, perfusion with high calcium or low sodium solutions engendered step wise changes in conduction slowing. In Chapter 7 the degree of conduction slowing produced by low sodium is examined with respect to nerve fibre conduction velocity. The slowest myelinated axons were found to suffer the largest drop in conduction velocity, on average, and had a greater tendency to block. This suggests a low safety factor for nerve conduction in these axons, which have a diameter of less than 4μ in the frog. As axons of a similar diameter mediate pain in man this finding may explain the analgesic properties of local anaesthetics.

In Chapter 8 changes in compound action potentials are recorded under a variety of conditions which are known to compromise nerve conduction. Suppression of fast and slow peaks in the compound action potential were noted and correlated to the previously described behaviour of single action potentials under similar conditions. This analysis indicated that while compound action potentials are useful for investigating the qualitative differences between two conditions, they are not appropriate for detecting the differential block of a specific group of axons.

CHAPTER 2**METHODS**

2. a. INTRODUCTION

Experiments were performed upon sciatic nerves of the frog (*Rana temporaria*) and the cat (*Felis domestica*). Frog sciatic nerves were dissected from animals in which the spinal cord and brain had been destroyed and experiments were conducted upon the isolated tissue. Cat sciatic nerves were studied *in vivo* in anaesthetized animals. A total of 134 frogs and 16 cats were used in these investigations.

2. b. FROG EXPERIMENTS

Frogs were obtained from the animal house where they had been kept in shallow water at between 2-5 °C. After being brought into the laboratory they were left to equilibrate to room temperature for approximately one hour. Frogs were then stunned, decapitated and pithed (both the spinal cord and the head).

The skin of the frog was removed and the body of the animal placed in a cork lined dissecting bath partially filled with Ringer solution. The legs of the frog were pinned out onto the cork to immobilise the preparation prior to sciatic nerve dissection.

2. b. 1. *Ringer solutions*

Ringer solutions were made up on the day of the experiment from stock solutions. The composition of ions (in mM) in the various solutions used in frog experiments are given in Table 1. All solutions were made up in distilled water, chemicals were ANALAR and were obtained from BDH Ltd. 5 mM HEPES free acid (N-2-Hydroxyethylpiperazine-N'-2-ethanesulfonic acid) (SIGMA) was added to all solutions and dilute NaOH and HCl added to adjust the pH to 7.4.

2. b. 2. *Sciatic nerve dissection*

The urostyle was removed to expose the three main central branches of the sciatic nerve trunk (the seventh, eighth and ninth spinal nerves). Connective tissue was removed from the sciatic notch and the muscles of the dorsal aspect of the thigh were carefully separated. The central branches of the sciatic nerve were transected as close to the spinal column as possible and the ends of the branches gripped firmly with fine

forceps. The central section of the nerve was then lifted from the abdomen and light tension applied to allow the nerve to be cut free from the sciatic notch and thigh muscles.

TABLE 1

THE CONCENTRATION OF IONS (mM) IN RINGER SOLUTIONS

| RINGER | Na ⁺ | Cl ⁻ | K ⁺ | Ca ⁺ | Chol | SO ₄ ²⁻ | Suc | HEPES | OSM |
|--------|-----------------|-----------------|----------------|-----------------|------|-------------------------------|-----|-------|-----|
| NORMAL | 112 | 116.5 | 2.5 | 2 | ---- | ---- | --- | 5 | 238 |
| LOW-Na | 28 | 116.5 | 2.5 | 2 | 84 | ---- | --- | 5 | 238 |

High potassium experiments:

| | | | | | | | | | |
|---------|-----|-------|-----|---|------|-------|-----|---|-----|
| NORMAL | 112 | 126.5 | 2.5 | 2 | 10 | ---- | --- | 5 | 258 |
| HIGH-K | 112 | 126 | 12 | 2 | ---- | ---- | --- | 5 | 257 |
| HIGH-K' | 112 | 26.4 | 12 | 2 | ---- | 47.35 | 53 | 5 | 258 |

Chol=Choline Chloride, *Suc*=Sucrose. *High-K'* refers to the high potassium, constant [K] [Cl] product solution. *OSM* is the osmolarity (calculated).

The leg was then reversed to expose the ventral aspect. Either one or both of the major branches of the tibial nerve which run to the plantar surface of the foot (tibial nerve and cutaneous crurus medialis inferior nerve) were cut at the level of the ankle joint and freed from the tissue as far as the knee. The leg was then returned to its dorsal aspect.

The gastrocnemius muscle was removed to expose the peroneal nerve branch. A cut was made in the connective tissue of the foot running from between the third and fourth toes to the ankle. This exposed the peroneus medialis nerve branch which was cut and freed from the tissue as far as the knee. The peroneus lateralis nerve branch was also dissected free from a slightly more lateral position.

Finally, the connective tissue around the knee was loosened and the sciatic nerve

pulled free from the central end. The ends of the nerve branches were then tied off with colour coded ligatures. The conduction distances between the central branches and the separate peripheral branches were measured at this point with a ruler, the nerves being stretched to take up any slack (judged by the disappearance of the spiral bands of Fontana, see Sunderland, 1978). The sciatic nerve dissection commonly took about fifteen minutes.

2. b. 3. *Stimulation and recording*

Nerves were mounted within a bath designed to allow either perfusion or compression of a section of the nerve between the stimulating and recording electrodes (see Figures 3 and 4). Either one or both of the main central nerve branches (the eighth and ninth spinal nerves) were mounted on bipolar silver wire electrodes and stimulated electrically using square wave voltage pulses of 0.1 ms in duration at a rate of 1/sec. These were produced by a Grass Instruments S8 two channel stimulator. The preparation was connected to the stimulator via a Grass Instruments SIU5 stimulus isolation unit.

Recordings were made from between 1-4 peripheral branches using bipolar silver wire electrodes. Recordings were pre-amplified either 100 or 1000 times by an Isleworth Electronics A101 pre-amplifier set to a bandwidth of 200 Hz-20 KHz. In the low sodium experiments Tektronix FM 122 low-level pre-amplifiers were used which were set to a bandwidth of 80 Hz-40 KHz. The nerve was earthed with a silver wire electrode placed on the nerve about mid-way between the recording and stimulating sites.

The signal recorded from nerve branches was displayed on a Medelec 4 channel oscilloscope. Permanent records were obtained using the Medelec oscilloscope which incorporated a slave oscilloscope-photosensitive paper system for this purpose, with typically 4-5 sweeps being superimposed on each trace.

The stimulator and oscilloscope were triggered from a 3 channel delay pulse generator designed and constructed for this project. The design of this device is shown in Figure 1.

The electrical stimuli applied to the central nerve branches evoked action potentials in myelinated axons. The action potentials were conducted down the length

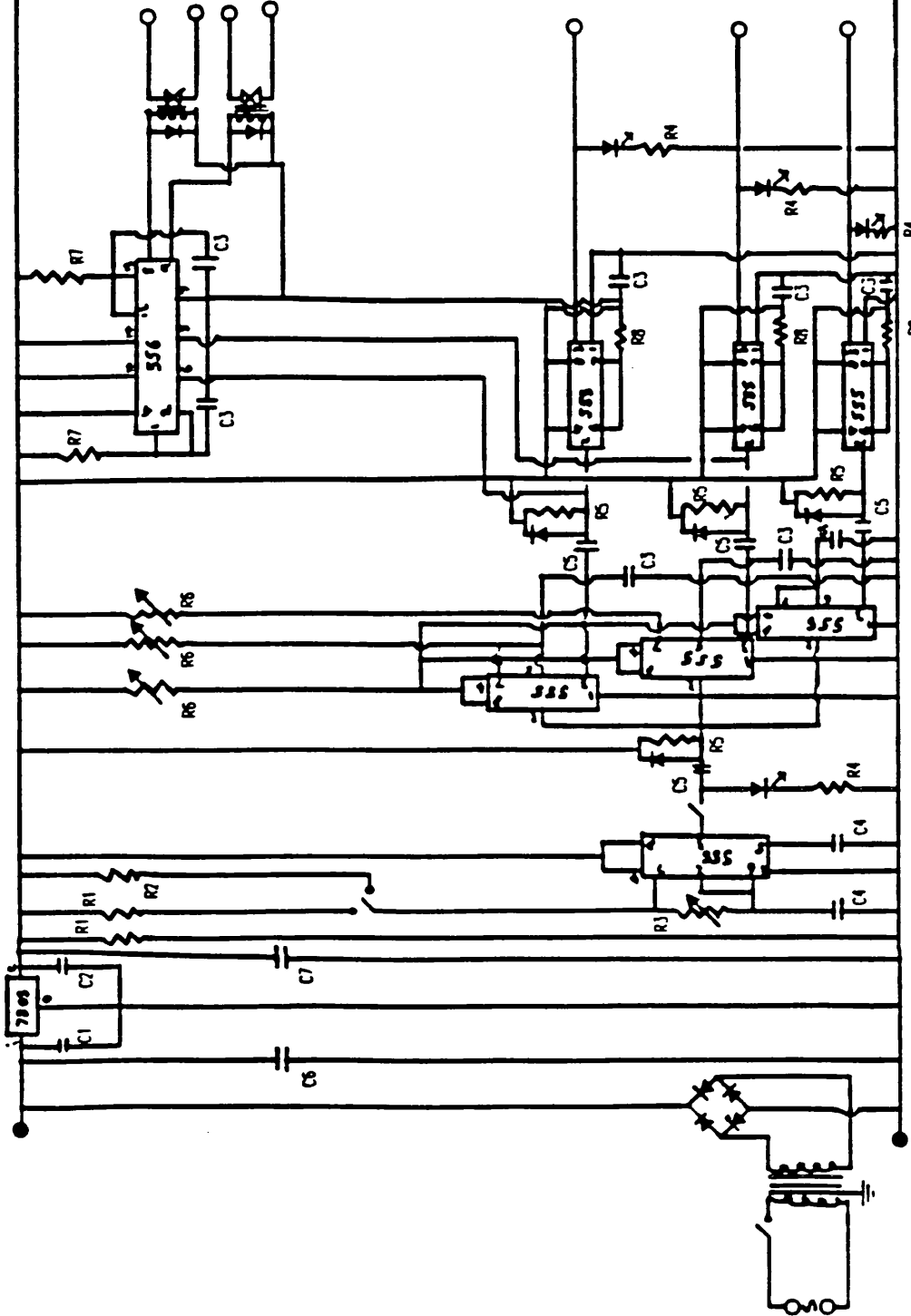

Figure 1

Circuit diagram of the gated pulse generator used for frog experiments. Three generations of circuits based upon 555 timer integrated circuits allowed the duty cycle and delay for three TTL pulses to be set. To allow easy control the duty period and pulse occurrence is indicated by LED's. In addition, channels 1 and 2 drive the closure of relays (used to trigger the Grass stimulator). $R1=4.7\Omega$, $R2=180\Omega$, $R3=10K\Omega$, $R4=15K\Omega$, $R5=1.2M\Omega$, $R6=0.5M\Omega$, $R7=1K\Omega$; $C1=0.22\mu F$, $C2=0.47\mu F$, $C3=1\mu F$, $C4=100\mu F$, $C5=1nF$, $C6=2.2MF$, $C7=10\mu F$.

of the nerve, traversing the region being perfused or compressed, and were recorded as unitary action potentials in the peripheral branches. Action potentials were identified as being myelinated on the basis of conduction velocity, with no action potentials with conduction velocities less than 3 m/sec being analyzed.

Stimulation typically evoked a number of unitary action potentials in each peripheral branch. The unitary nature of the potentials was assessed by observing the all or nothing manner in which they were recruited as the stimulus voltage was gradually altered. Only potentials which were clearly unitary were analyzed.

Typically only one or two of the nerve branches were suitable for recording and other branches were discarded. Nerves were rested between periods of stimulation which did not last in excess of 10 seconds.

2. b. 4. *Distribution of conduction velocities*

The distribution of conduction velocities of the 496 axons recorded from frog nerves is shown in Figure 2. A qualitatively similar distribution of axon diameters was found in *Rana pipiens* by Gasser and Erlanger (1927), with maxima at similar locations according to the scaling factors between frog axon diameter and conduction velocity determined by Tasaki, Ishii and Ito, (1943) and Hutchinson, Koles and Smith (1970).

A comparison with the findings of Gasser and Erlanger reveals, however, that a disproportionate number of slow fibres have been recorded during this study, compared to fast fibres. It appears, therefore, that the extracellular recording technique employed in these experiments has a recording bias toward small myelinated axons. This is probably because rapidly conducted action potentials are not as well separated as slowly conducted action potentials, ie. they are recorded over a smaller range of conduction latencies, and were, therefore, more often discarded as being unclear (eg. Figure 11, page 59).

2. b. 5. *Methods for frog nerve perfusion experiments*

Prior to being mounted for recording the nerves were transferred from the dissecting bath to a cork mat soaked in Ringer solution. The mat incorporated a section of black Perspex which provided visual contrast over the central section of the nerve. Nerves were pinned onto the cork via the colour coded ligatures and periodically

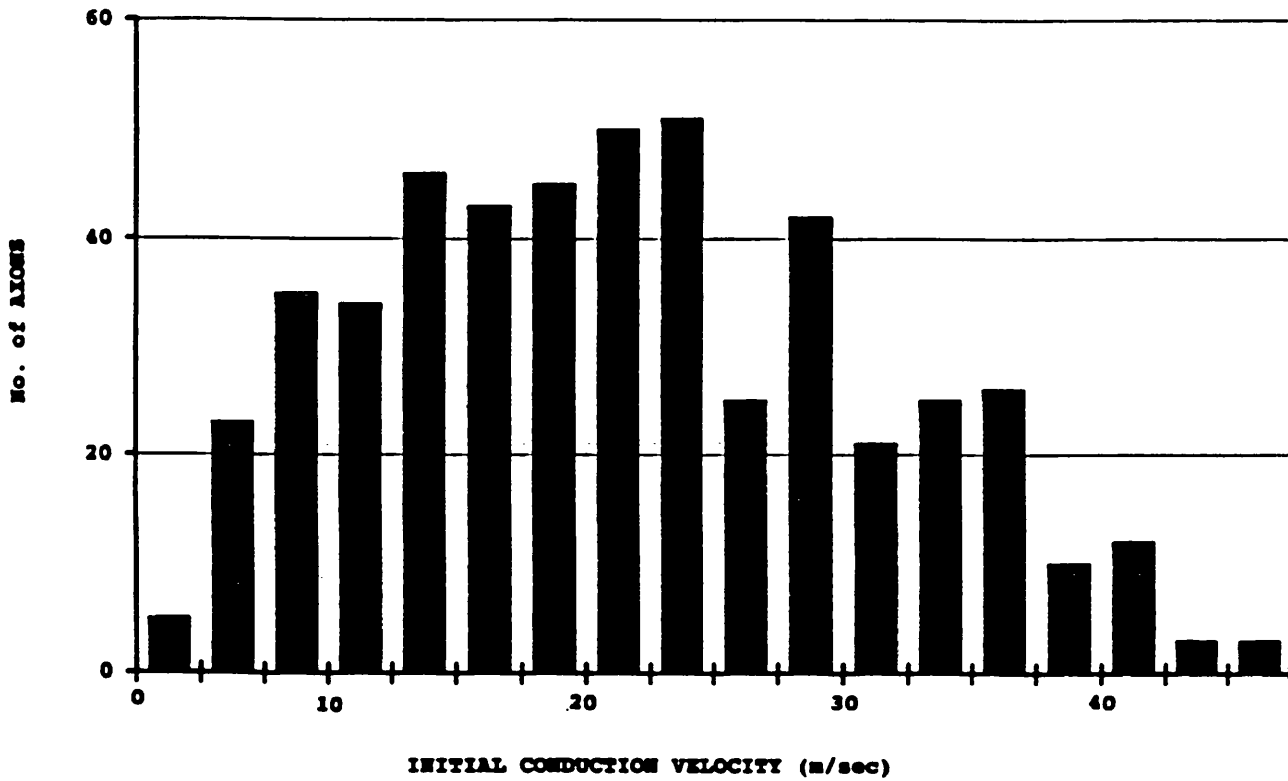

Figure 2

Histogram showing the distribution of nerve fibre conduction velocities recorded from the frog nerve.

moistened with Ringer solution. The nerve was visualised under a Carl Zeiss binocular dissecting microscope and illuminated by a schott KL 500-T cold light source.

With care, two to four nerve branches were separated to the level of the major division at the knee. Adapting the technique of Uehara (1958), the majority (approximately 80%) of nerve fibres were then removed from each branch for a 20 mm length below the major division. This served to both limit the number of action potentials recorded from peripheral branches and reduced the barrier for diffusion of solutions onto the remaining fibres.

Nerves were transferred to a recording bath designed to allow perfusion of a 14 mm length of the thinned out sections of the nerve branches. The experimental set up is shown in Figure 3. Typically, control records were taken for 30-40 minutes prior to exchange of normal Ringer solution for test solution.

2. b. 6. *Controls*

In order to examine whether any of the effects observed in the results might be due to deterioration of the preparation control experiments were performed. The preparation was set up as normal and the perfusion medium exchanged from normal Ringer to normal Ringer. In 2 experiments the conduction of 4 unitary action potentials was monitored for a period of 330 minutes, employing the normal stimulus routine. After that period average conduction velocity of the action potentials had fallen to 97% of the initial value. This indicates that action potentials recorded from this preparation have a stable conduction velocity for the first five hours, and results are unlikely to contain any significant artifact as a consequence of the preparation ageing over a similar period.

In some of the high potassium perfusion experiments reported in chapter 6 action potentials are recorded for up to 500 minutes. In some of these experiments conduction velocity did begin to drift towards the end of the experiment. However, the majority of the results in chapter 6 were obtained within the initial 300 minute period when conduction velocity was stable.

2. b. 7. *Methods for frog nerve compression experiments*

Connective tissue was removed from the sciatic nerves but they were not

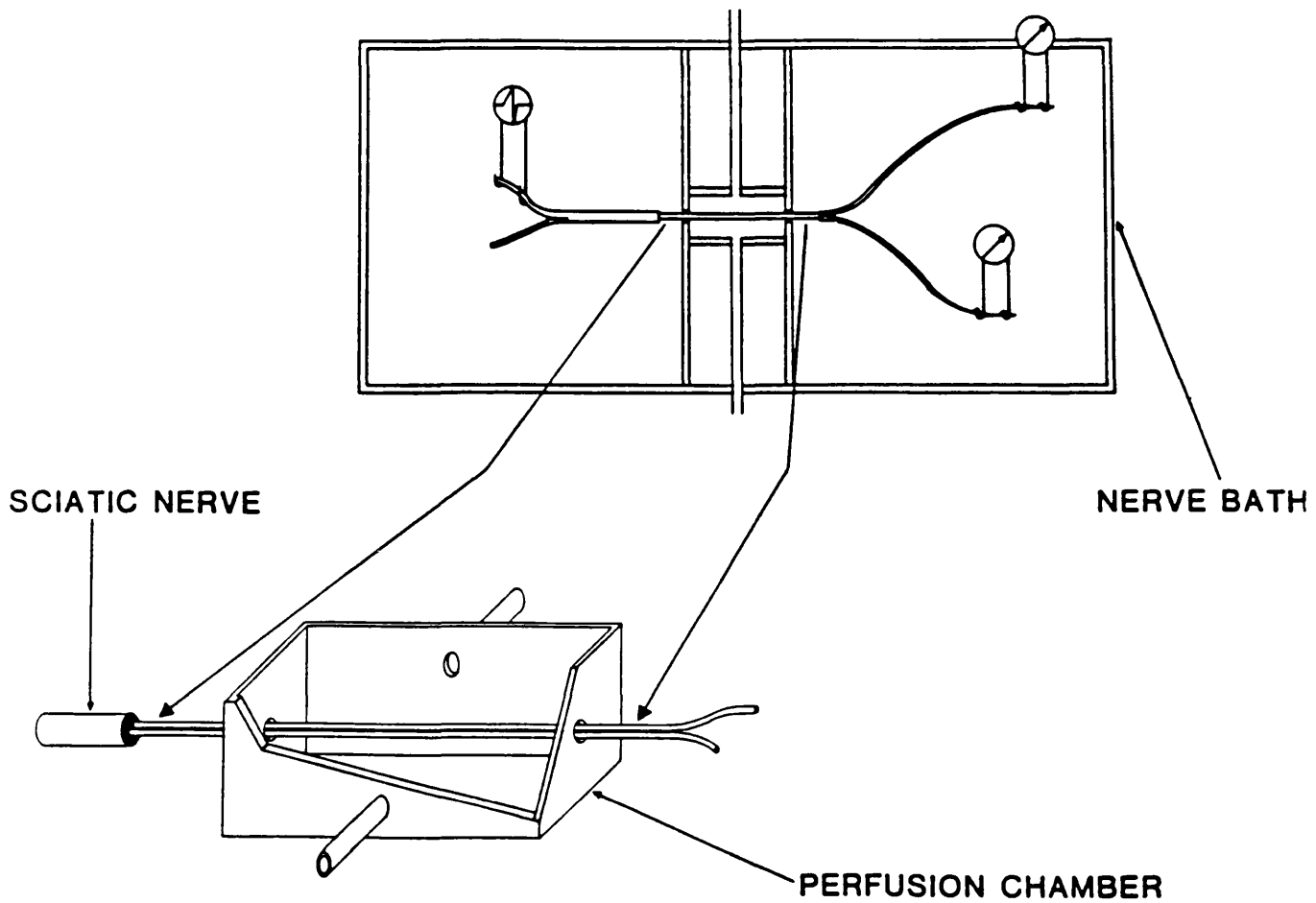

Figure 3

Experimental arrangement used for nerve perfusion experiments. One central nerve branch is shown placed upon a stimulating electrode and two peripheral branches are on recording electrodes. A 14 mm central section of the thinned out length of nerve is enclosed within a perfusion chamber (shown is greater detail in the inset).

desheathed. Nerves were mounted in a recording chamber designed to allow compression of a central portion of their length. The mid-part of the chamber consisted of a compliant rubber sleeve through which the nerve was threaded and which was encased within a Perspex tube. The rubber sleeve was everted over the ends of the tube and held in place by secured rubber washers. The space between the Perspex tube and the rubber sleeve was connected to a pressure bottle and manometer via a side arm. This allowed the rubber sleeve to be inflated, thereby compressing the nerve. The chamber was filled with liquid paraffin. The recording set up and compression device are shown in Figure 4.

After control records had been taken for between 20-40 minutes the rubber membrane within the compression chamber was inflated. The pressure within the chamber was monitored with the manometer and either 750, 250 or 20 mmHg was applied. The length of nerve within the chamber was 24 mm long, the length of nerve is unlikely to be critical, however, as compression exerts its effects at the edges of a compressed region (Ochoa *et al.* 1971).

2. b. 8. *Compound action potential experiments*

Compound action potentials were elicited by voltage pulses 0.1 msec in duration applied at a rate of 1/second to the central nerve end via a bipolar silver wire electrode. Recordings were made from a single large peripheral branch which was crushed between the poles of the recording electrode to achieve monopolar recording conditions.

The stimulus voltage was adjusted such that only the alpha and beta components of the A wave of the compound action potential, identified on the basis of conduction velocity and threshold, were recorded. Measurements of compound action potential amplitude were made from a line drawn connecting the start and end of the total potential, as judged by eye. Control records were taken for 30 minutes prior to initiating either perfusion or compression of the central nerve section, using similar apparatus to that shown in Figures 3 and 4.

In compression experiments, pressures of either 100 or 300 mmHg were applied to a length of nerve 14 mm long. In nerve cooling experiments sciatic nerves were mounted within the perfusion chamber previously described. The central chamber of the bath was then irrigated with Ringer solution cooled to between 0-1 °C by immersion

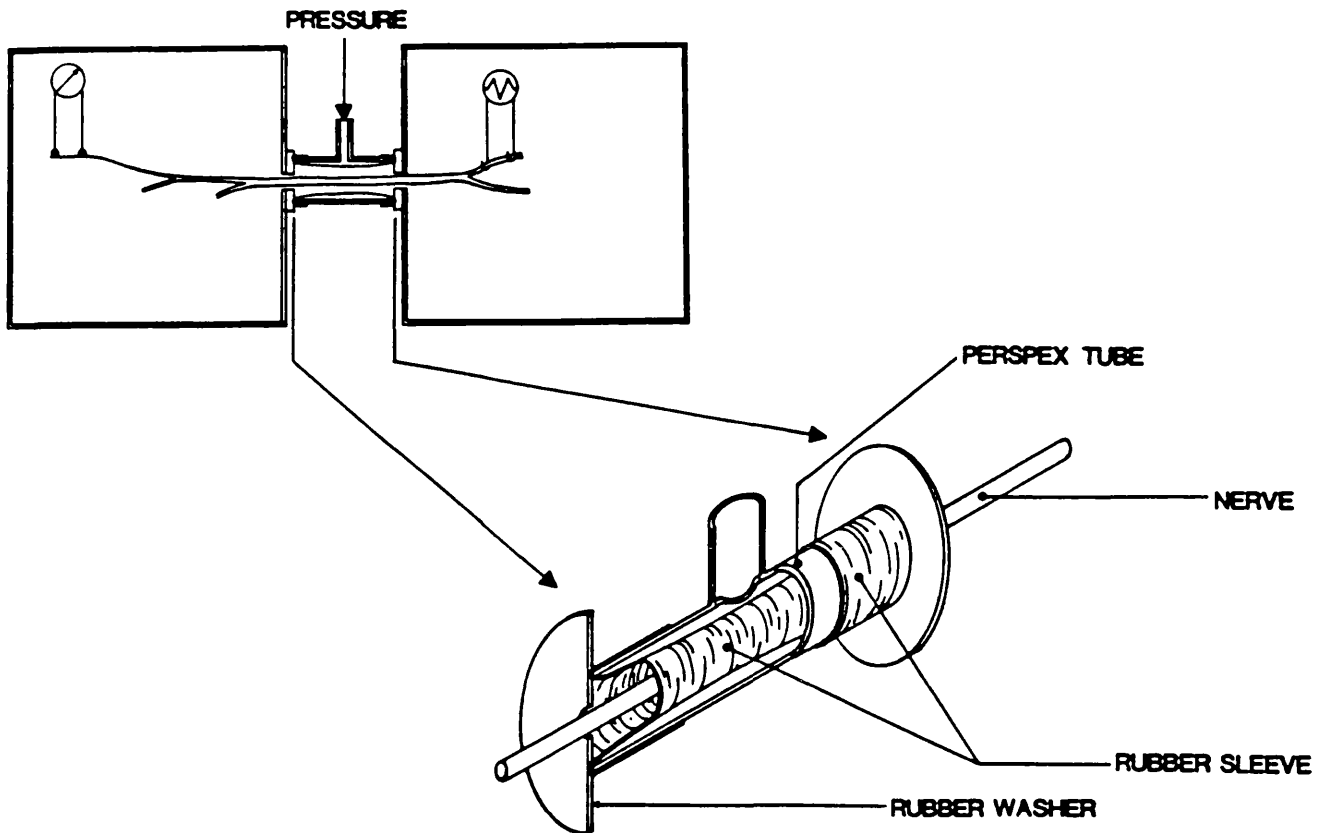

Figure 4

The experimental arrangement for nerve compression experiments. Nerves were mounted in a paraffin bath incorporating an enclosed central chamber through which the nerve was threaded. The chamber consisted of an inflatable rubber sleeve passing through and everted over the ends of a perspex tube. The interior of the tube was connected to a pressure bottle via a side arm. Raising the pressure in the pressure bottle inflated the sleeve, compressing the nerve within. The ends of the perspex tube were clamped between two rubber washers to create a seal and to prevent the expansion of the rubber sleeve out of the tube.

within an ice-salt jacket. This arrangement was not designed to allow accurate control of the nerve temperature, the nerve was simply cooled arbitrarily while changes in the compound action potential were monitored. When the compound action potential had stabilised the pump was reconnected to Ringer solution of room temperature until full recovery was evident. Similar procedures were used for perfusion experiments with low sodium and procaine Ringer solutions.

2. c. CAT EXPERIMENTS

A total of 16 cats were employed in this study, ranging between 2.6 and 3.1 Kg in weight. Food was withheld from the animals for approximately 16 hours prior to being brought into the laboratory.

2. c. 1. *Solutions used in cat experiments*

Saline at a concentration of 0.9% was made up the day before the experiment with distilled water and NaCl (BDH). On the morning of experiments heparin saline solution was made by diluting 1000 units of sodium heparin (Multiparin, CP Pharmaceuticals) in 100 mls of saline. 400 mg of chloralose (BDH) was dissolved in 40 mls of saline and warmed to 50-60 °C, care being taken not to heat the chloralose beyond this point. Once the chloralose had dissolved it was loaded into syringes capped with filters and stored in a water bath heated to 50 °C. In some experiments a solution of 40 mg/ml gallamine triethiodine (Flaxedil, May and Baker) was diluted 1:5 in saline for injection.

2. c. 2. *Initial experimental procedures*

Animals were constrained within an airtight box connected to a Boyle induction machine and vaporiser. The induction machine passed a mixture of 5% halothane, NO₂ and O₂ (in equal proportions) into the box and exhaust gases were removed by an extraction fan. The gas mixture produced anaesthesia of the cat within 10 minutes, at which point the animal was transferred to a dissection table. Halothane anaesthesia was continued on the dissection table using a mask applied to the animal's face.

Surgery performed under halothane anaesthesia included cannulation of the radial

vein, common carotid artery and trachea. The carotid artery was connected to a mercury manometer to allow blood pressure to be monitored.

Following tracheal cannulation the concentration of halothane was reduced to 0.5-1% and chloralose slowly injected into the radial vein while blood pressure was monitored. The halothane was then turned off and the remainder of the full dose of chloralose administered (70mg/kg). Throughout the course of the experiment the level of anaesthesia was periodically assessed by monitoring the blood pressure and the diameter of the pupils. If there were any signs that the animal was coming out of anaesthesia a further 10 mg of chloralose was injected. The cat was positioned on a homeostatic blanket and a rectal probe was inserted to allow feedback control of temperature to 39 °C.

2. c. 3. Peripheral nerve and spinal cord dissection

The skin above the spinal column was shaved as was the skin on the dorsal aspect of the left rear leg. An incision was made in the skin above the spinal column, running from pelvic to mid-thoracic levels. The skin was parted and any bleeding cauterized. The muscles running lateral to the spinal column were then removed with care being taken to minimise blood loss by the use of the cautery and bone wax.

The dorsal aspect of the vertebrae between L4-L7 was then removed. The laminectomy was performed by lifting the spinal column with a clamp fixed to the spinous process of the vertebra rostral to that being laminectomised. Bone rongeurs were then used to clip small sections from the vertebra. When enough of the vertebra had been removed to sufficiently expose the dorsal surface of the spinal cord the clamp was moved one vertebra rostral and the process repeated. When the laminectomy was complete the spinal cord was covered with saline soaked gauze. The skin was then pinned together to prevent dehydration.

The skin of the dorsal aspect of the left hind limb was opened from over the ischial tuberosity of the pelvis down to the area over the achilles tendon. Incisions were made either side of the biceps femoris muscle where it attaches to the ischial tuberosity and sutures passed under the muscle at the attachment site. These were then tied off and the biceps femoris cut away from the bone to expose the underlying sciatic nerve trunk.

The remainder of the biceps femoris muscle was carefully removed allowing

access to the hamstring nerve branches and the sural nerve. The hamstring nerve branches were cut and the semimembranosus branch placed with the anterior biceps branch. Likewise the semitendinosus branch was placed with the branch to posterior biceps. Colour coded ligatures were tied around the cut ends of these branches as with all other nerve branches.

The two or three branches which constitute the sural nerve were cut some distance from the sciatic nerve trunk and tied together. The common peroneal nerve branch was cut where it passes over the peroneus longus muscle.

The lateral and medial heads of the gastrocnemius muscle were divided to reveal the branches of the tibial nerve. The branches to plantaris, flexor digitorum longus (FDL) and to medial and lateral gastrocnemius-soleus were cut and tied off, as was the remaining component of the tibial nerve.

2. c. 4. *Experimental set up*

Following completion of the surgical procedures the cat was transferred to a stereotaxic table designed to allow stable conditions for recording. Two clamps were attached to the spinal column and were in turn fastened onto support bars running either side of the animal. Pins were inserted into either side of the pelvis and together with the clamps these sufficed to support the weight of the animal. The head was clamped into a head holder. The underside of the animal was wrapped in a homeostatic blanket which, together with several warm light sources, maintained the correct body temperature (39 °C) as determined by the rectal probe.

A bilateral pneumothorax was performed by incision through the skin over the ribs and through the underlying muscle layer and pleura. Tubes were inserted into the openings to allow free passage of air. These were capped by balloons which prevented dehydration of the lungs.

The animal was connected to a Starling respiratory pump and in experiments in which gallamine was used it was injected at this point (8 mg gallamine triethiodide). A sampling probe from a capnograph (Gould Capnograph IV) was introduced into the expiratory outflow to measure end tidal CO₂, which was maintained at approximately 6% by control of the tidal volume.

2. c. 5. *Recording*

The skin flaps around the spinal cord and hind limb were sutured onto side supports to form pools which were filled with warm liquid paraffin. The temperature within the pools was monitored with thermometers.

The spinal cord was visualised with a Zeiss Opmi 6-CH binocular surgical microscope and cold light source. Using fine forceps and scissors the dura mater over the cord was opened to expose the spinal nerve roots.

Three or four bipolar silver wire recording electrodes were lowered into the spinal cord pool. One pole of each electrode was positioned upon the back muscles. The second poles of the electrodes were positioned over the spinal nerve roots. Thin strands of either dorsal or ventral root filaments were detached from the cord with fine forceps and placed upon the recording electrodes. Recordings from spinal root filaments were therefore monopolar with respect to the muscles of the back. The final selection of filaments for recording was made on the basis of the number and clarity of unitary action potentials observed following peripheral nerve stimulation.

In nerve compression experiments the signal from each spinal cord electrode was amplified 1000 times using a Tectronix FM 122 low-level pre-amplifier. The signal was then displayed on a Medelec 4 channel oscilloscope and also recorded on a Racal 4 channel FM tape recorder.

In the ischaemia experiments recordings were amplified 1000 times by Digitimer D150 amplifiers and displayed on a Medelec 4 channel oscilloscope. Data was recorded on a 8 channel Biologic DTR-1800 digital audio tape recorder.

2. c. 6. *Distribution of conduction velocities*

The distribution of conduction velocities in the 210 muscle efferent axons and 610 muscle afferent axons recorded from cats are shown in Figure 5 (axons carried from the sural nerve, which will be of cutaneous origin, have not been included). The muscle efferents (motor axons) clearly form two maxima at 75 and 35 m/sec, which corresponds well with the alpha and gamma groups of motor axons. Likewise, the broad distribution of slow afferent axons and a distinct fast peak correspond well with the distributions of type I (fast) and Types II-IV afferent fibres in cat muscle nerves (Boyd and Davey, 1968). The distribution of the various groups of axons is similar to

Figure 5

Distribution of conduction velocities in cat muscle afferent and efferent axons. The distributions of nerve fibre velocities indicates a non-biased recording protocol in the cat experiments.

Efferent Axons

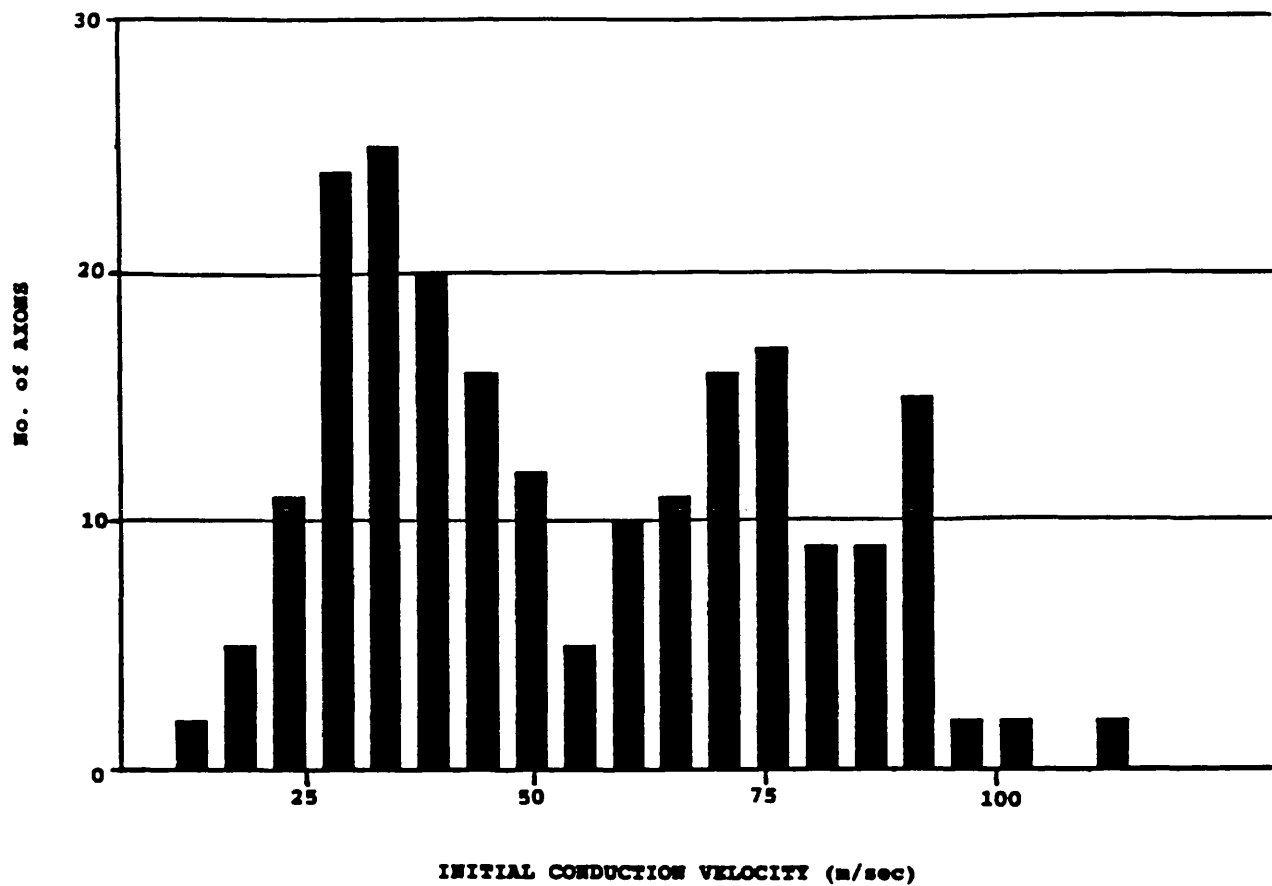

Afferent Axons

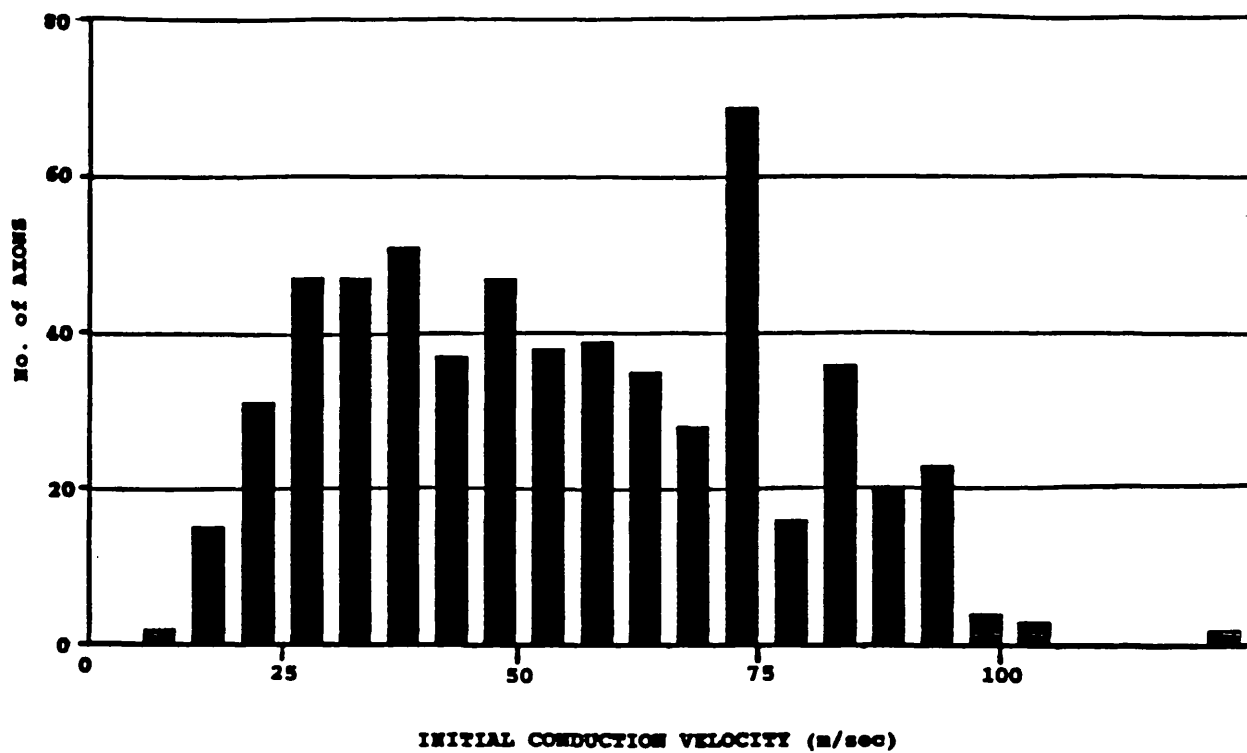

that found by Boyd and Davey indicating that no significant recording bias is present in the cat experiments.

2. c. 7. *Stimulation*

Pairs of bipolar silver wire electrodes were lowered into the leg pool and the peripheral nerve branches carefully positioned onto separate electrodes. The electrodes were connected via a Grass Instruments SIU5 stimulus isolator unit and a 12 way selectable switch box to a Grass Instruments S88 two channel stimulator. The stimulator provided 0.1 msec square wave voltage pulses at the rate of 1/second. The stimulator and oscilloscope were triggered by a digitimer D4030 gated pulse generator.

2. c. 8. *Recording routine*

Electrical pulses applied to individual peripheral nerve branches evoked action potentials which were propagated along the nerve and spinal roots. The action potentials were then recorded from the nerve roots as unitary action potentials. The unitary nature of potentials was assessed by observing all or nothing recruitment as the stimulus voltage was gradually varied.

Recordings were made following stimulation of the peripheral nerves in turn, each nerve being stimulated 8-10 times per recording period and rested for the intervening 40-50 seconds. The set up for recording is shown in Figure 6.

2. c. 9. *Methods used for nerve ischaemia experiments*

Experiments were performed on nine cats. The first seven experiments were not primarily designed to investigate the question addressed here and consequently the amount of data collected from each of these experiments was smaller than in two subsequent experiments. These latter two experiments were performed exclusively to address the current question. Conclusions made at the end of the first seven experiments were in agreement with those made in the final two experiments.

Blood pressure was recorded with a Statham P23 blood pressure transducer amplified by a Devices amplifier. This signal was led into a analogue to digital converter (Cambridge Electronic Design, model:1401) and displayed on a personal computer (Tandon, model:286) using software specialised for recording and averaging

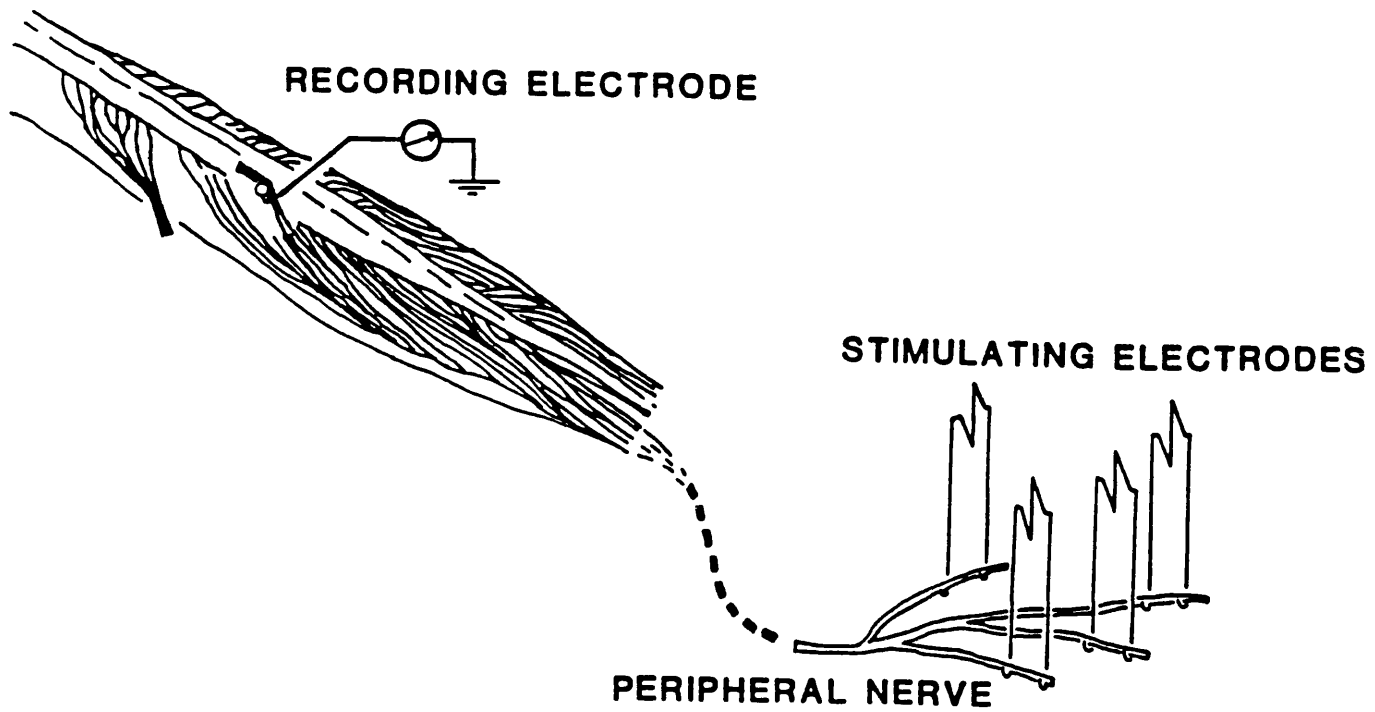

Figure 6

The experimental arrangement used during ischaemia experiments. The spinal cord and peripheral nerves are shown. Four peripheral nerve branches are positioned upon stimulating electrodes and a single spinal nerve root is shown ready for recording.

neurological signals (Cambridge Electronic Design, programme:Sigavg). The input bridge of the Devices amplifier was balanced and the transducer was calibrated using a mercury manometer. In each of these experiments four spinal filaments, two dorsal and two ventral, were selected for study.

After control records had been taken for 35 minutes a 10 ml air embolism was injected into the radial vein. Within 20 seconds following injection the blood pressure fell to below 10 mmHg. This is illustrated in Figure 7. Following cardiac arrest, records were taken periodically and the conduction of action potentials monitored during the ensuing ischaemia. The temperature in the leg pool was monitored with a thermometer following cardiac arrest and was found to fall by less than 0.5 °C over a half hour period.

At the end of the experiment the nerves and spinal roots were dissected out and the conduction distances measured. Together with measurements of the conduction latency between the onset of the stimulus artifact and the peak of the action potentials, this was then used to calculate initial conduction velocities.

2. c. 10. *Methods for cat nerve compression experiments*

Dissection, stimulation and recording were all very similar to the cat nerve ischaemia experiments. In the compression experiments, however, no recordings were made from ventral root filaments. All the data, therefore, is from sensory axons.

In addition to the procedures used in the ischaemia experiments the sciatic nerve trunk was freed from surrounding connective tissue for a length of about 3 cm between the knee joint and the pelvis. A brass plate was then inserted beneath the nerve and an pneumatic rubber balloon held within a rigid outer chamber positioned over the plate, secured by two locating pins. The gap between the plate and the outer chamber was constant for all experiments.

The plate was covered with a thin layer of cork which had a shallow groove cut into it to partially accommodate the nerve. Inflation of the pneumatic balloon then led to pressure being exerted upon a 24 mm length of the sciatic nerve trunk, the groove cut into the cork helping to spread the compressing force evenly. It is noteworthy, however, that as the effects of compression will be almost entirely restricted to the edges of the compressed region the actual length of nerve being compressed is not an

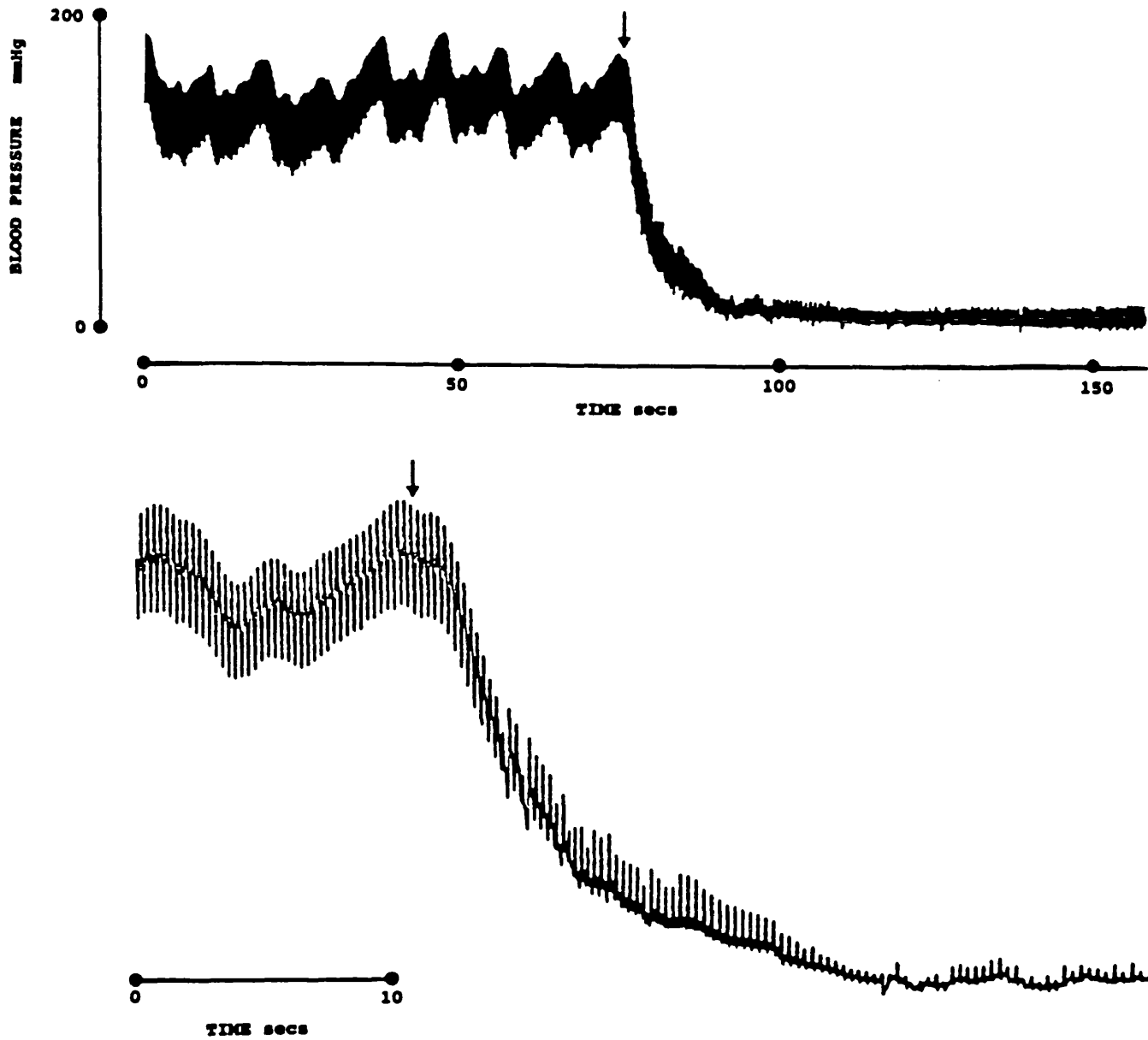

Figure 7

A continuous record of blood pressure taken during a nerve ischaemia experiment. At the arrow a 10 ml air embolism was injected into the radial vein, a procedure which results in a sudden fall in blood pressure.

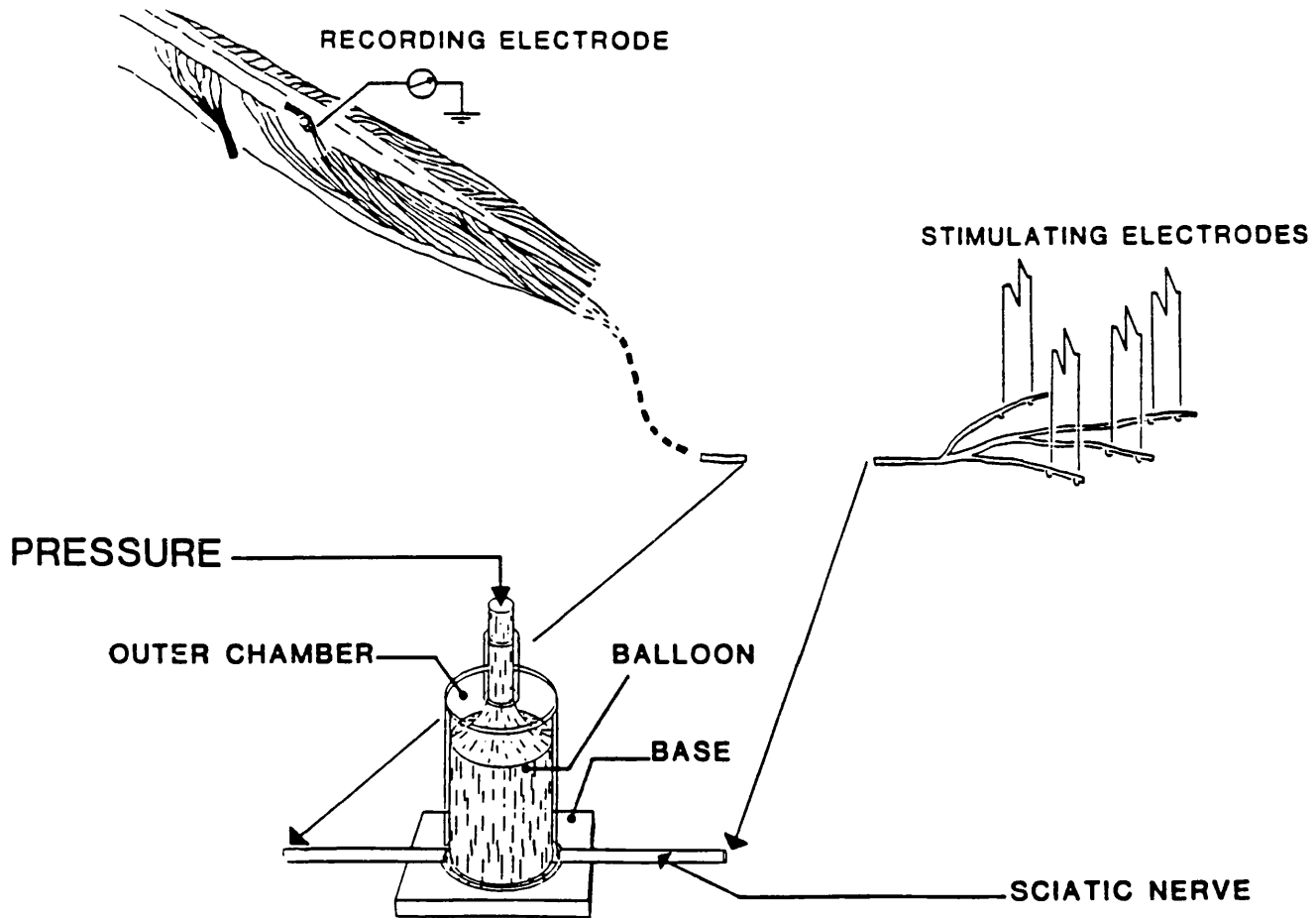

Figure 8

Experimental arrangement for cat nerve compression experiments. The spinal cord, peripheral nerves and the device used to apply compression to the sciatic nerve trunk are illustrated. One spinal root filament is shown positioned upon a monopolar recording electrode and multiple branches of the sciatic nerve trunk are placed upon individual stimulating electrodes.

important factor. The experimental arrangement is shown in Figure 8.

Following the installation of the nerve compression device, control records were taken for 20-40 minutes. Pressure of either 70 or 250 mmHg was then applied to the nerve and records taken periodically until all action potentials had failed.

SECTION I

THE RELATIVE IMPORTANCE OF NERVE
DEFORMATION AND NERVE ISCHAEMIA IN THE
CONDUCTION BLOCK PRODUCED BY NERVE
COMPRESSION

INTRODUCTION TO SECTION I

The action potential is the functional unit of signal transmission in the nervous system. The axon is the morphological substrate of the action potential, the major purpose of the axon being faithful action potential conduction. Any interruption in the functioning of axons can, therefore, have disastrous consequences for higher organisms. The most profound instances of this are the severely pathological conditions associated with large scale disruption of axon function eg. multiple sclerosis, spinal cord injury and leprosy.

Less severe but more common are conditions associated with compression of peripheral nerves where they pass through regions offering little protection, or through tight anatomical spaces. There are a large number of clinically recognised disorders of this type which can be divided into two categories, the chronic and the acute nerve compression disorders (Spinner and Spencer, 1974; Harriman, 1977; Sunderland, 1978; Gilliatt 1980 a, b; Lundborg, 1988).

Chronic nerve compression disorders (nerve entrapments) are conditions which evolve over a period of time under circumstances of mild or intermittent compression. Typically, chronic compression is characterised, in the early stages, by nocturnal paraesthesiae (eg. pins and needles). Chronic compression disorders tend to worsen over a period of months. Symptoms change to day time paraesthesiae and numbness followed by mild and then severe loss of sensory perception and muscle function together with pain.

Carpal tunnel syndrome is an example of a chronic nerve compression disorder (Spinner and Spencer 1974; Sunderland, 1976, 1978; Gilliatt, 1980 b; Lundborg, 1988). It results from raised pressure within the carpal tunnel in the wrist (Gelberman, Hergenroeder, Hargens, Lundborg and Akeson, 1981). The median nerve passes through the carpal tunnel and the compression which results from the raised pressure affects the use of the hand. The symptoms can generally be relieved by surgical decompression, although the time course of recovery is related to the severity of the condition (Gilliatt, 1980 b; Lundborg, 1988).

Acute nerve compression disorders usually result from a single episode of severe compression, are rapid in onset, involve sudden loss of function and usually improve

spontaneously over a period of weeks to months. An example of acute compression is Saturday night palsy (Trojaborg, 1970; Sunderland, 1978; Gilliatt, 1981; Lundborg, 1988), where the brachial plexus is crushed by the weight of the body, an event often associated with alcohol intoxication. Acute nerve compression disorders can also result from the over-inflation of a tourniquet prior to surgery, the resulting tourniquet palsy takes between 3-6 months to recover (eg. Bruner, 1951; Mukherjee, 1977; Aho, Saino, Chianta and Varpanen, 1983).

The nerve trunk has a composite structure arranged to maximise resistance to the mechanical disruption which leads to compression lesions. Thus, nerve fibres are embedded within a matrix of connective tissue (endoneurium) enclosed into fascicles by the perineurium (sheath of Key and Retzius). Fascicles are themselves embedded within the connective tissue of the epineurium which also contains the major nutritive vessels of the nerve trunk (Sunderland, 1978; Lundborg, 1988). The thickness of the epineurium varies between nerves and also along the nerve length, being greatest where nerves are likely to experience physical stress (Sunderland and Bradley, 1949; Sunderland, 1978). Up to 88% of the nerve trunk can be taken up by the epineurial connective tissue which serves to buffer the nerve fibres from compression and protect against stretching (Sunderland and Bradley, 1949; Sunderland 1978).

Blood vessels supplying the nerve trunk traverse a convoluted route allowing a considerable degree of latitude for nerve movement before the blood supply becomes compromised (Lundborg and Rydevik, 1973; Lundborg, 1988). This is not only important during limb movement but also during nerve compression, which often involves a degree of nerve stretching (Rydevik, Lundborg and Shalak, 1987).

Upon entering the nerve trunk the supply vessels branch and form a functional plexus giving the nerve a remarkably high safety factor for perfusion (Bentley and Schlapp, 1943 a; Blunt and Stratton, 1956; Lundborg, 1970, 1975; 1988; Bell and Weddell, 1984 a, b; Rechthand and Rapoport, 1987). Thus, ligation of the supply vessels of the rabbit sciatic-tibial nerve over a 15 cm length causes little disturbance of the nerve's blood supply, while complete transection of the nerve at the end of this region does not disrupt blood flow for a 7 cm region below the nearest supply vessel (Lundborg, 1970, 1975).

Thus, it appears that the development of resistance to compression and ischaemia

has been an important element in the evolution of nerve structure. That there are special features of peripheral nerve structure providing protection from both ischaemia and compression has prompted the explanation of the pathophysiology of nerve compression in terms of both physical deformation of nerve fibres (Fullerton and Gilliatt, 1967 a, b; Anderson, Fullerton, Gilliatt and Hern, 1970; Ochoa, Fowler and Gilliatt, 1971, 1972; Fowler, Danta and Gilliatt, 1972; Ochoa and Marotte, 1973; Marotte, 1974; Ochoa, 1980; Gilliatt, 1980 a, b) and ischaemia of the nerve following occlusion of blood vessels (Sunderland, 1976, 1978; Harriman, 1977; Gelberman *et al.* 1981; Lundborg, Gelberman, Minteer-Convery, Lee and Hargens, 1982; Gelberman, Szabo, Williamson, Hargens, Yaru and Minteer-Convery, 1983; Powell and Myers, 1986; Lundborg, 1988; Kalichman and Myers, 1991).

Historical background

For many years the findings of Lewis, Pickering and Rothchild (1931), Grundfest and Kartell (1935), Grundfest (1936) and Denny-Brown and Brenner (1945 a, b) encouraged the belief that conduction block resulting from compression was primarily the result of nerve ischaemia. This conclusion was based largely on the assumption that hydrostatic pressure, as experienced by a whole nerve within a pressure vessel, is an adequate model of the compression experienced by a region of nerve. Ochoa *et al.* (1971, 1972) were the first to point out that this is far from the case and that peripheral nerves suffer considerable physical distortion at the edges of a region of compression which will not occur in a pressure vessel.

In a histological analysis of acute compression lesions of baboon tibial nerve Ochoa *et al.* (1971, 1972) described compression edge effects involving a pattern of axonal damage characterised by translocation of fibre components. For example, the nodes of Ranvier of many of the larger nerve fibres were found to have been physically displaced away from the compressed region, a pattern of damage which was localised to the border zones of the compressed region of nerve. Such damage can only be explained in terms of a physical deformation of the fibres resulting from the shearing forces acting at these points (Lundborg, 1988). This is powerful evidence that physical deformation resulting from pressure gradients is the main pathophysiological event underlying nerve injury during acute nerve compression.

However, Powell and Myers (1986) have suggested an alternative explanation of compression lesions. These authors invoked a model in which collapse of transperineural blood vessels (the vessels that supply the fascicles) during low degrees of compression generates an ischaemic field adjacent to the perineurium. This would result in specific ischaemic damage of nerve fibres situated near to the perineurium, while specific damage of these fibres has been noted on a number of occasions following compression (Aguayo, Nair and Midgley, 1971; Spinner and Spencer 1974; Powell and Myers 1986).

Extending this hypothesis Powell and Myers (1986) suggested that higher degrees of compression extend the ischaemic field from the fascicle perimeter into the fascicle interior until all nerve fibres are affected. Further, necrosis of Schwann cells and demyelination was noted following relatively low compression by Powell and Myers (1986), which suggests that ischaemia might produce the demyelination noted following both acute and chronic compression lesions. It is, however, difficult to reconcile the distortion of nerve fibre structure so well demonstrated by Ochoa *et al.* (1971, 1972) following acute compression, with an ischaemic lesion.

There is, however, a considerable body of evidence that ischaemia is important during chronic compression lesions. Thus, Sunderland (1976, 1978) has argued that in the carpal tunnel syndrome intrafascicular oedema following ischaemia within the carpal tunnel obstructs the venous return from the medial nerve, producing further ischaemia, oedema and pressure. This results in conduction block of the medial nerve and formation of an intraneural scar. This argument is supported by evidence that fascicular oedema can occlude the transperineural vessels and generate fascicular ischaemia (Lundborg, 1975; Myers, Murakami and Powell, 1986; Kalichman and Myers, 1991).

Lundborg and co-workers have provided considerable corroborative evidence for the role of ischaemia in chronic nerve compression disorders. Following the observation that tissue pressure surrounding the medial nerves of patients with carpal tunnel syndrome varies between 32-110 mmHg (Gelberman *et al.* 1981), a series of experiments were performed upon healthy subjects. Pressure in this range was generated within the carpal tunnel and nerve conduction monitored (Lundborg *et al.* 1982; Gelberman *et al.* 1981, 1983; Lundborg, 1988). This revealed a development of conduction block in sensory and motor fibres which could not be relieved by

decompression of the carpal tunnel if the arm's blood supply was occluded simultaneously at a more proximal site.

These experiments revealed that the critical pressure for nerve fibre viability was 50 mmHg. This value was found to be higher in hypertensive subjects (Szabo, Gelberman, Williamson and Hargens, 1983), leading to the conclusion that the critical pressure for nerve viability is some 45 mmHg below the mean arterial blood pressure (Lundborg, 1988).

This finding can be related to experiments in which the degree of compression required to inhibit the blood supply to nerve is examined. Such experiments indicate that pressures in the range 45-120 mmHg bring about an occlusion of nerve blood vessels (Bentley and Schlapp 1943 a, b; Rydevik, Lundborg and Bagge, 1981; Ogata and Naito 1986, Matsumoto 1983).

These indications that ischaemia is a major factor in chronic nerve compression disorders are not conclusive. There is evidence, for example, that fibre deformation is also present. In a series of studies of naturally occurring lesions of the chronic type in guinea pig nerve (Fullerton and Gilliatt 1967 a, b; Anderson *et al.* 1970; Ochoa and Marotte, 1973; Marotte, 1974; Gilliatt, 1980 a; Ochoa, 1980), histological examination revealed deformation of the myelin sheaths. The deformation was of a similar form to that described during acute compression (Ochoa *et al.* 1971; 1972) but of a lesser degree. Similar structural changes have also been found in man (Harriman, 1977; Lundborg, 1988).

It is clear, therefore, that there is uncertainty about the relative importance of fibre deformation and ischaemia in the loss of function associated with both mild and severe nerve compression. In the current work three animal models have been employed to investigate this question. The animal models used include the isolated frog sciatic nerve. Results from this preparation are later used to provide a comparison with the results from *in vivo* cat nerve experiments. It is important, therefore, to consider the merits and demerits of this comparative physiological methodology. This is particularly true as it is hoped that it will be possible to extrapolate the results to clinical events.

Frog nerve is a robust tissue with a low metabolic rate (Okada and McDougal, 1971) which allows it to survive in a physiological state under very simple conditions. The nerve is ideal for the study of deformation as, having a low oxygen requirement,

it does not rapidly become anoxic during compression. Thus, as the nerve is isolated, when compression is applied the resultant effects cannot be due to ischaemia or anoxia and must be largely restricted to the actions of deformation alone.

The structure of the frog sciatic nerve is distinct (Krnjević, 1954), being monofascicular, and it is an easily accessible tissue available all year round. These characteristics have made the frog sciatic nerve ideal for use in many important electrophysiological experiments. Thus, in the past, amphibian (usually frog) nerve has been used; by Galvani (1791) to first demonstrate the presence of electricity in animals; by Du Bois Raymond (1848) to observe the first action potential; by Gasser and Erlanger (Erlanger and Gasser, 1924; Gasser and Erlanger, 1927) to record the form of the compound action potential; by Huxley and Stämpfli (1949) and by Tasaki and Takeuchi (1941, 1942) to reveal the saltatory nature of action potential conduction in myelinated axons; by Huxley and Stämpfli (1951 a) to record the membrane and action potentials of myelinated axons; and by Dodge and Frankenhaeuser (1958, 1959) to voltage clamp the node of Ranvier.

The characteristics of the action potential of the frog nerve have since been confirmed as being remarkably similar to those of mammalian nerves, with the exception that delayed potassium currents are different (Grissmer, 1986; Röper and Schwarz, 1989; see page 102, page 167), while the two tissues are known to have a remarkable similarity in physiology and morphology (Krnjević, 1954; Stämpfli and Hille, 1976; Lundborg, 1988).

Considering the extent of the body of knowledge of frog nerve neurophysiology, and considering that this knowledge has been extrapolated to mammalian and human nerves in many studies, and that mammalian and frog nerves are so similar in structure, it seems reasonable to draw comparisons between frog and mammalian nerves in this study. Frog nerve will, therefore, be used in a model of nerve deformation while cat nerve will be used to investigate nerve ischaemia. Combining these studies together results obtained with a cat nerve model of *in vivo* compression will be interpreted.

CHAPTER 3

THE PATTERN OF CONDUCTION BLOCK INDUCED BY NERVE
COMPRESSION AND ATTRIBUTED TO DEFORMATION

INTRODUCTION

When a nerve runs through a region of raised pressure there are two series of events which may result in block of action potential conduction. Firstly, the three dimensional structure of the nerve will come under stress. The radial forces acting upon the nerve trunk during compression will act to constrict, resulting in longitudinal displacement of the substance of the nerve as it is squeezed (Lundborg, 1988; Rydevik, Lundborg and Skalak, 1987). Shearing forces arise at the edges of the compressed region (Lundborg, 1988) and axons are likely to become traumatised (Ochoa *et al.* 1971, 1972) and their ability to function become compromised (Bentley and Schlapp, 1943 b; Gilliatt, 1980 a) at these points.

Secondly, constriction of the nerve trunk during compression will tend to occlude the nerve's blood supply. This will lead to ischaemia of the nerve, an event which is clearly pathophysiological and which can in itself block nerve conduction (Lewis *et al.* 1931; Magladery, McDougal and Stoll, 1950; Hershey and Wagman, 1966; Fox and Kenmore, 1967; Lundborg *et al.* 1982; Powell and Myers, 1986; Dahlin, Shyu, Danielsen and Andersson, 1989; Olmarker, 1990; Kalichman and Myers, 1991; Lachance and Daube, 1991).

Both ischaemia and deformation of nerve structure can result in conduction block. For example, the application of a tourniquet to the arm induces conduction failure of all the nerves within the ischaemic field (ie. the whole arm), not simply at the point where they run beneath the tourniquet. This conduction block is manifestly the result of ischaemia, rather than being a product of pressure upon the nerve at the level of the tourniquet (Lewis *et al.* 1931, Bentley and Schlapp 1943 b; Hayashi, Becker, White and Lee, 1987; Bostock, Baker, Grafe and Reid, 1991 a).

On the other hand Ochoa *et al.* (1971, 1972), have described the structural damage produced at the site of application of relatively severe compression in baboon nerve. These workers reported that the structure of the nerve is damaged by the compression, with the pattern of damage being such that could only result from deformation of the nerve trunk under the compressing force.

It is the purpose of the current chapter to investigate the pattern of conduction block produced by the deformation associated with compression in the absence of

ischaemia. It would be technically rather difficult to perform such an analysis on mammalian nerve, which has a high metabolic rate and, therefore, rapidly becomes ischaemic during compression *in vivo*, and anoxic during compression *in vitro*. The sciatic nerve of the frog, however, has a very low metabolic rate (Okada and McDougal, 1971), and was therefore selected for this study.

Wright (1946) and Okada and McDougal (1971) have shown that frog sciatic nerves can conduct action potentials for tens of minutes even in a completely anoxic environment. I endeavoured to minimise any anoxia in these experiments by using a very thin and therefore presumably porous membrane to generate pneumatic compression. It was hoped, therefore, that compression of the frog nerve will involve deformation of the nerve without nerve function becoming significantly affected by anoxia. Experimental controls indicate that this was indeed the case.

3. b. RESULTS

3. b. 1. *Compression resulting from 250 mmHg of pressure*

Figure 9 shows a series of recordings taken from a peripheral branch of the frog sciatic nerve following electrical stimulation of the central end. At time zero the stimulus artifact is followed by a number of action potentials, these have been marked with arrows. At various points over the subsequent 75 minute period these action potentials disappear from the records in an all or nothing manner. This conduction block occurs as a consequence of the 250 mmHg of pressure which is applied to the 24 mm central section of the nerve at time zero.

Slowing of action potential conduction tends to precede conduction block in these experiments and can be most easily seen in the slow conducting, long latency action potentials. This conduction slowing, and the all or nothing manner in which action potentials fail, allow the points at which all 10 unitary action potentials present in these records to be determined. A similar approach has been described by other workers examining the conduction block of unitary action potentials (eg. Paintal, 1965 a; Franz and Iggo, 1968; Franz and Perry, 1974).

The initial conduction velocity of the action potentials prior to the application of pressure was calculated. Survival time (the time to conduction block following

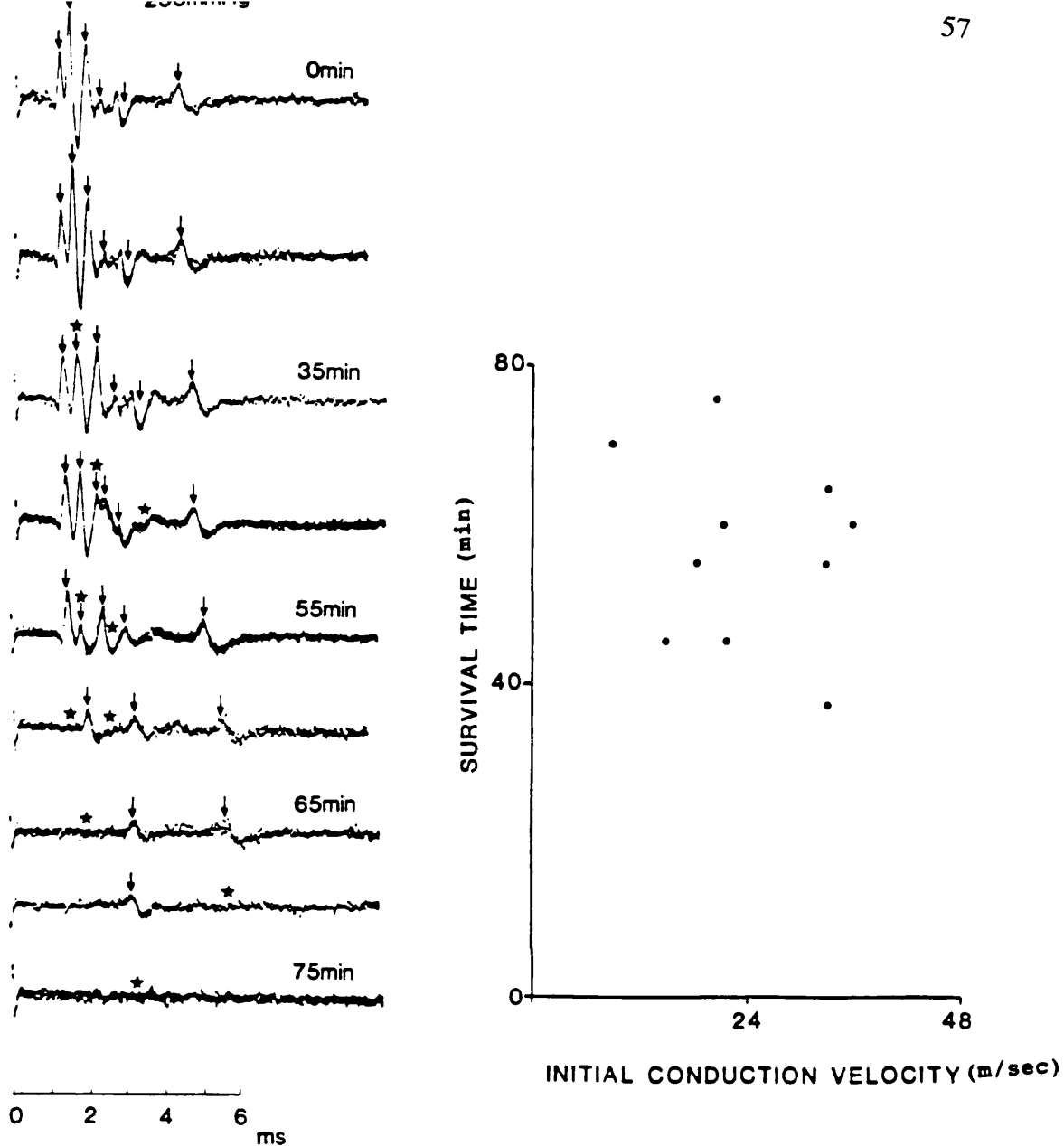

Figure 9

On the left are a series of records taken from an isolated frog sciatic nerve during the application of 250 mmHg of pressure over 24 mm. A number of unitary action potentials can be seen (indicated by arrows). The latency of the potentials increases during compression and individual potentials can be seen to fail at various points (marked with stars). On the right the data is plotted with survival time following the onset of compression against initial conduction velocity.

application of pressure) has been plotted against initial conduction velocity on the right of Figure 9.

The plot shown on the right of Figure 9 indicates that if there is any relationship between these two variables in this data it is obscured by a wide degree of scatter ($r=0.3$, $P=0.47$). However, the slope of the linear regression lines fitted to data from the seven nerve branches which produced more than 4 data points are shown in Figure 10 (top). It can be seen that in all cases a negative slope was found. To confirm that susceptibility to compression is really dependent on conduction velocity (and therefore on axon diameter (Hursh, 1939)), data from all 8 nerves recorded has been pooled in Figure 10 (bottom), which shows 148 data. In this plot, and in the plot shown in Figure 12, the data is not normally distributed.. To allow a meaningful linear regression analysis the data has therefore been plotted as the square root of survival time, to produce a more normal distribution.

Although there is much underlying scatter evident in Figure 10 (bottom) a linear regression analysis reveals a significant ($P<0.001$) underlying tendency for the fast conducting action potentials to block first (the slope of the correlation has been included as an arrow in Figure 10 (top)). Thus we can conclude that 250 mmHg of pressure, applied to the nerve over a 24 mm length, tends to block conduction first in fast conducting axons, which are those with the largest diameter. The average time taken to block is 50.4 minutes (average conduction velocity=23.4 m/sec).

The scatter which is so evident in Figures 9 and 10 (bottom) is of interest, and has not been observed in earlier compound action potential studies of frog nerve compression (Gasser and Erlanger, 1929). Although some experimental error is undoubtedly contributing to the scatter in the current data, scatter in the effect of compression upon nerve fibres cannot be explained in terms of experimental error alone. Thus, in Figure 9, of the 10 unitary action potentials which can be observed to block following application of 250 mmHg of pressure, several block in a reverse order to that found to be generally true from Figure 10. For example it can be clearly seen that after 65 and 75 minutes of compression the slowest unitary potential of all blocks before a faster conducting one.

Figure 10

250 mmHg pressure experiments. Top: The slope of the regression analysis for square root of survival time against initial conduction velocity for the seven nerve branches with the most number of unitary potentials. The arrow represents the slope of the regression analysis performed upon all the data. Bottom: Square root of survival time of 148 action potentials recorded from isolated frog sciatic nerves during 250 mmHg of pressure plotted against the initial conduction velocity. A linear regression line has been fitted; Correlation coefficient $r = -0.43$, probability of correlation $P < 0.001$.

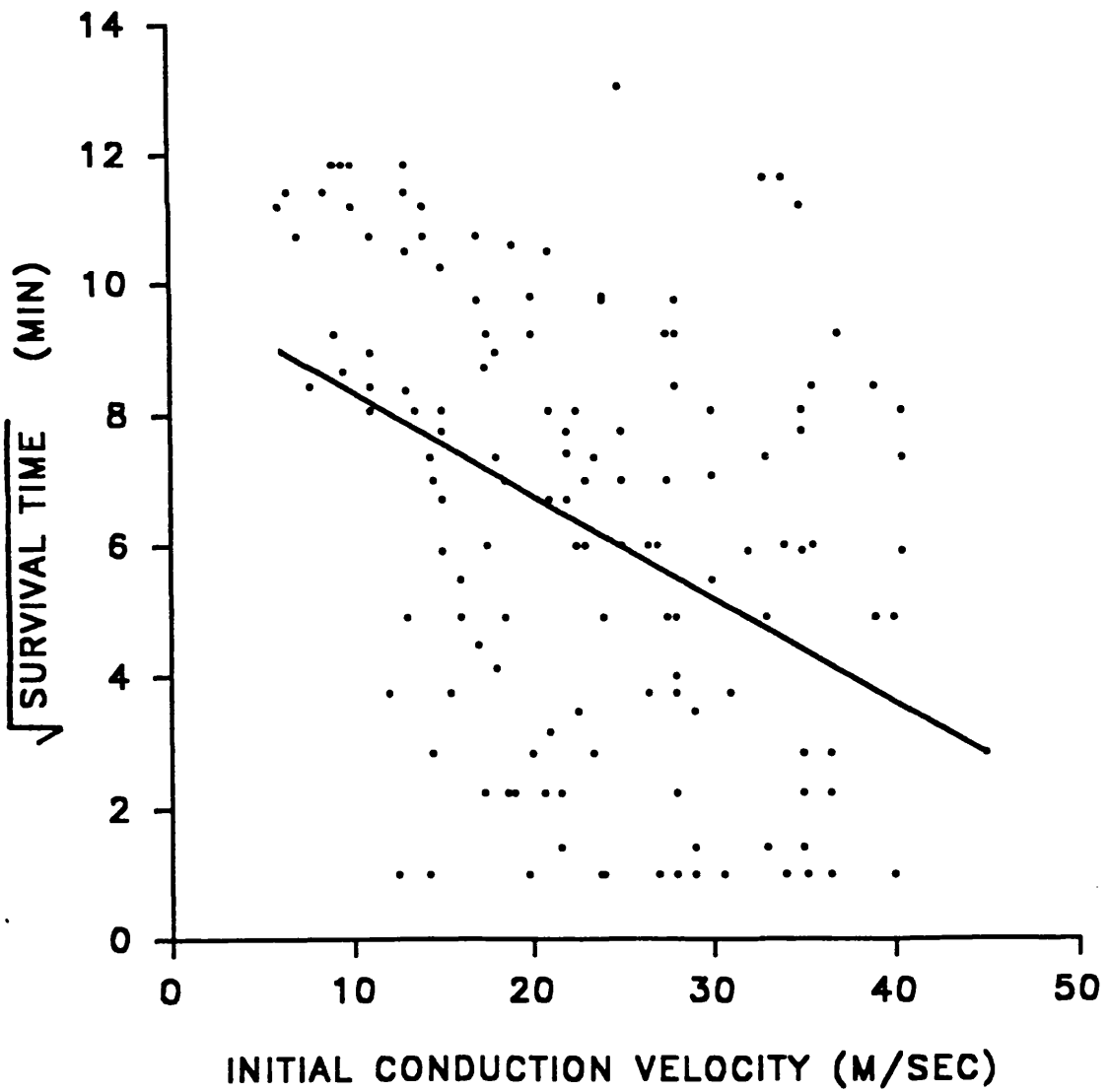
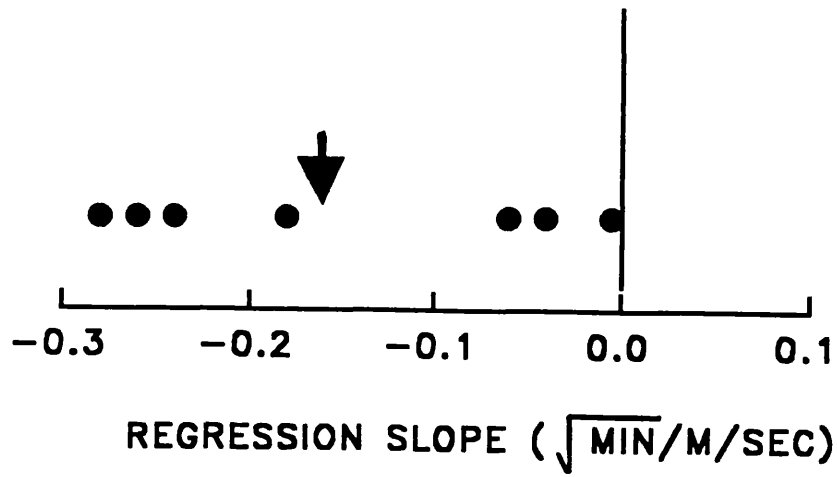

3. b. 2. *Compression resulting from 750 mmHg of pressure*

Figure 11 shows a series of action potentials recorded from a nerve during compression produced by 750 mmHg of pressure. Over a 14 minute time course most of the action potentials recorded from the nerve exhibit conduction failure and disappear from the record. In this example only the six slower potentials are distinct and the group of faster potentials has been ignored. On the right the data is plotted as before with survival time against initial conduction velocity.

In Figure 12 (top) the slope of the regression lines fitted to the data from the seven most productive nerve branches has been plotted, showing that in most nerves there is a positive slope. In Figure 12 (bottom), 246 data points collected from 17 compression experiments in which 750 mmHg of pressure was applied are plotted with survival time following application of pressure against initial conduction velocity. It is clear that this plot has some different characteristics to that found during 250 mmHg of pressure (Figure 10). For example, under this very high degree of compression the relationship between survival time and conduction velocity is characterised by a weaker correlation than at 250 mmHg of pressure. In addition, statistical analysis shows that the underlying relationship involves the slow unitary action potentials blocking first, rather than the fast ones (linear regression, $r=0.28$, $P<0.001$) (the slope of the regression line is included as an arrow in Figure 12 (top)). The average time taken to block is 10.9 minutes (average conduction velocity = 22.2 m/sec).

3. b. 3. *Rate of conduction block produced by compression*

As might be expected the rate of block was noticeably different at the two degrees of compression. Under 250 mmHg of pressure action potentials blocked within 2-170 minutes, taking on average 50.4 minutes ($n=148$). When 750 mmHg of pressure was applied failure occurred within 3-46 minutes, the average being 10.9 minutes ($n=246$). These figures are in good agreement with the results of Denny-Brown and Brenner (1944 b).

3. b. 4. *Anoxia over the compressed region*

In these experiments the frog sciatic nerve will receive oxygen from the paraffin which surrounds it over the majority of its length. During compression, however,

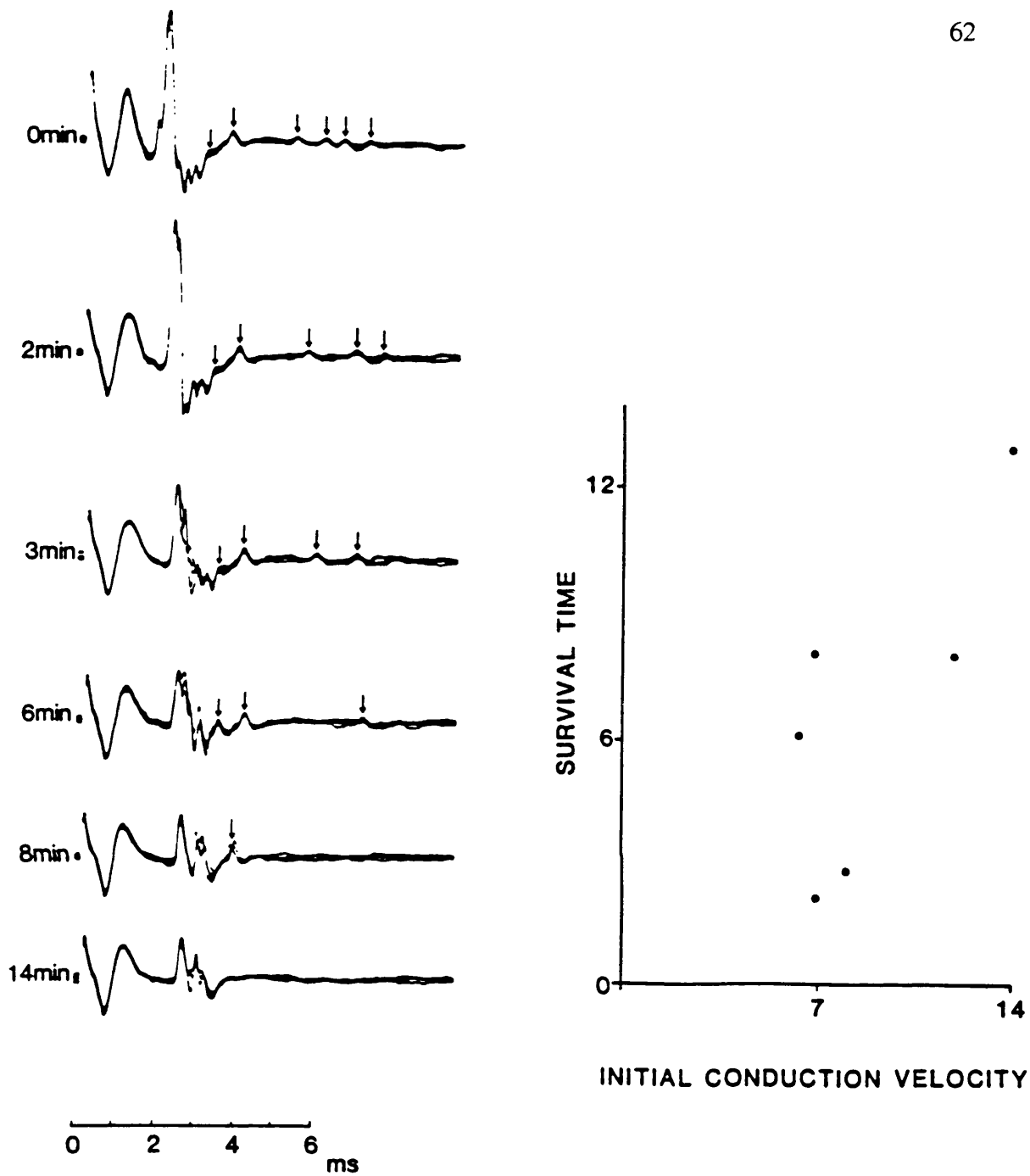
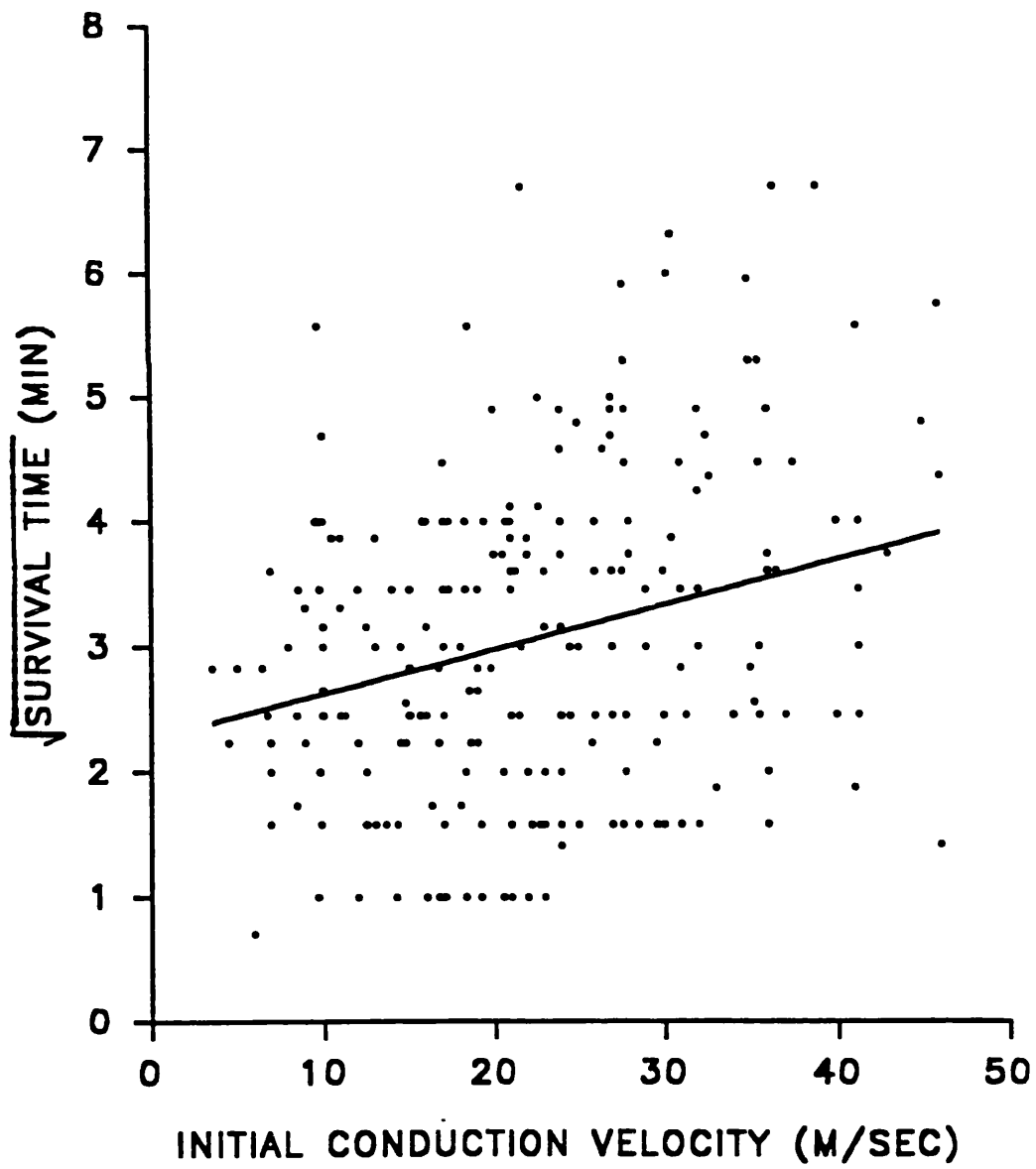
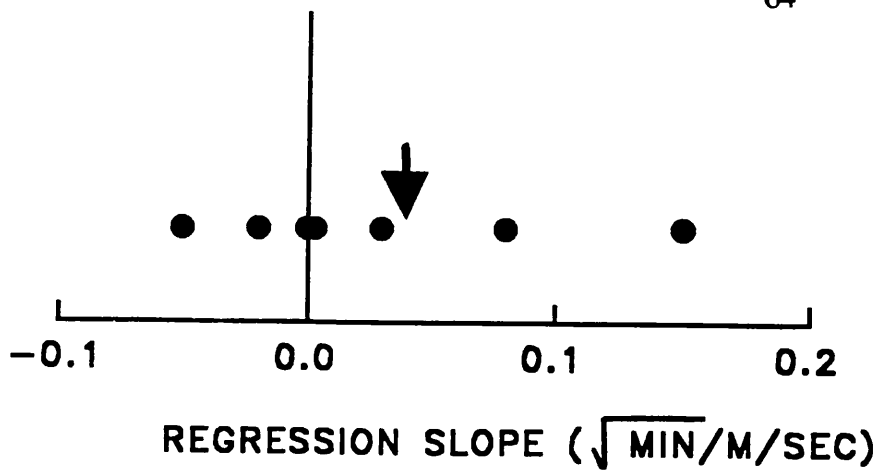

Figure 11

On the left are a series of records taken from an isolated frog sciatic nerve during the application of 750 mmHg of pressure. The six slower action potentials have been marked with arrows and can be seen to fail at various times. The group of faster potentials were considered too indistinct to analyze. On the right the data is plotted with survival time against initial conduction velocity.

Figure 12

750 mmHg pressure experiments. Top: The slope of the regression analysis for square root of survival time against initial conduction velocity for the seven nerve branches with the most number of unitary potentials. The arrow represents the slope of the regression analysis performed upon all the data. Bottom: The square root of survival time following application of 750 mmHg of pressure is plotted against initial conduction velocity for 246 action potentials. A linear regression line has been fitted ($r=0.28$, $P<0.001$). An order of block is found with the slow conducting action potentials tending to fail first.



oxygen diffusion from the paraffin to the length of nerve within the compression sleeve will be restricted. The compression sleeve was constructed from very thin (6μ prior to stretch), and therefore presumably porous, rubber tubing yet it is conceivable that the length of nerve within the sleeve may become anoxic during compression.

In order to evaluate whether anoxia is affecting the nerve during compression a series of control experiments were performed. Nerves were mounted within the bath as normal and a pressure of approximately 20 mmHg was applied. This pressure served to collapse the compression sleeve firmly about the nerve and so cut off the diffusion of oxygen from the paraffin. In Figure 13 it can be seen that of fifty seven action potentials recorded in these experiments only five (9% of total) had blocked after three hours. The failure of this small number of potentials might well be accounted for by the low degree of deformation resulting from the applied compression. It therefore seems unlikely that anoxia is having any significant effect upon nerve conduction during these compression experiments.

3. b. 5. *Compound action potential experiments*

A series of experiments in which compound action potentials were recorded were performed in an attempt to corroborate the unitary action potential data. To the left of Figure 14 are two series of compound action potential recordings made during compression of the frog sciatic nerve. The length of nerve compressed is shorter than in the unitary action potential experiments; this was to minimise problems arising from action potential conduction slowing (see chapter 8). An unwanted consequence of this, however, was that different degrees of pressure were needed to produce the contrasting effects found with unitary action potential recording.

Thus, in Figure 14 the compound action potential recorded during the lower degree of compression (100 mmHg of pressure) suffers a fall in amplitude with time, and it appears that the large early component falls by the greater amount. Under the higher compression (300 mmHg of pressure) the fall in amplitude appears to effect the slow component to a greater degree.

On the far right of Figure 14 the ratio of the amplitude of these two components (the fast alpha and the slower beta) is plotted against the fall in amplitude of the alpha component for these and three further sets of data. Thus, conduction block progresses

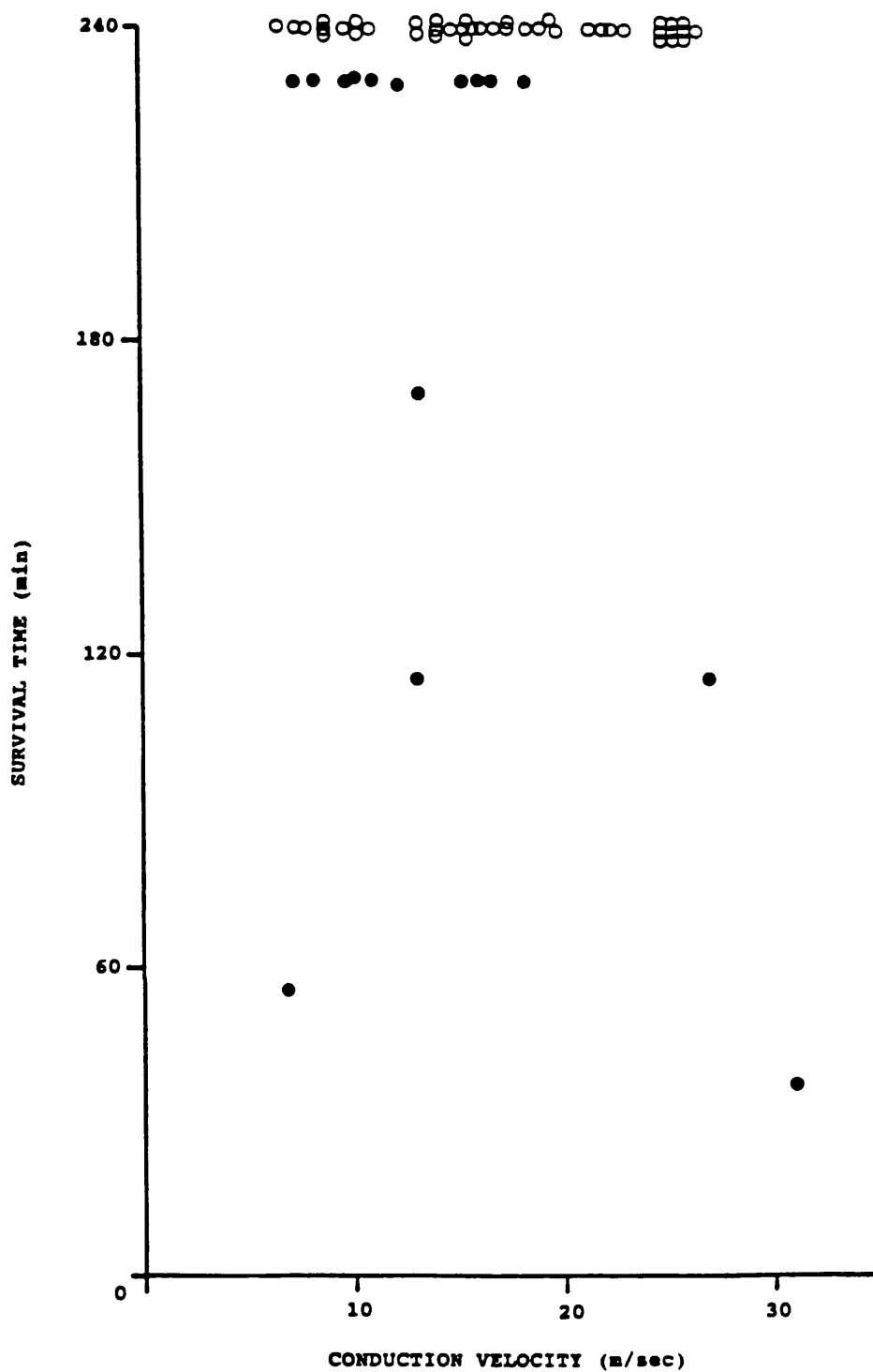

Figure 13

The effects of 20 mmHg of pressure upon conduction of 57 action potentials. Conduction block is indicated by the filled symbols, open symbols indicate action potentials which had not blocked after the full 330 minutes. 20 mmHg was a degree of pressure which served to collapse the compression sleeve firmly and thus presumably cut off the supply of oxygen to the central section of nerve.

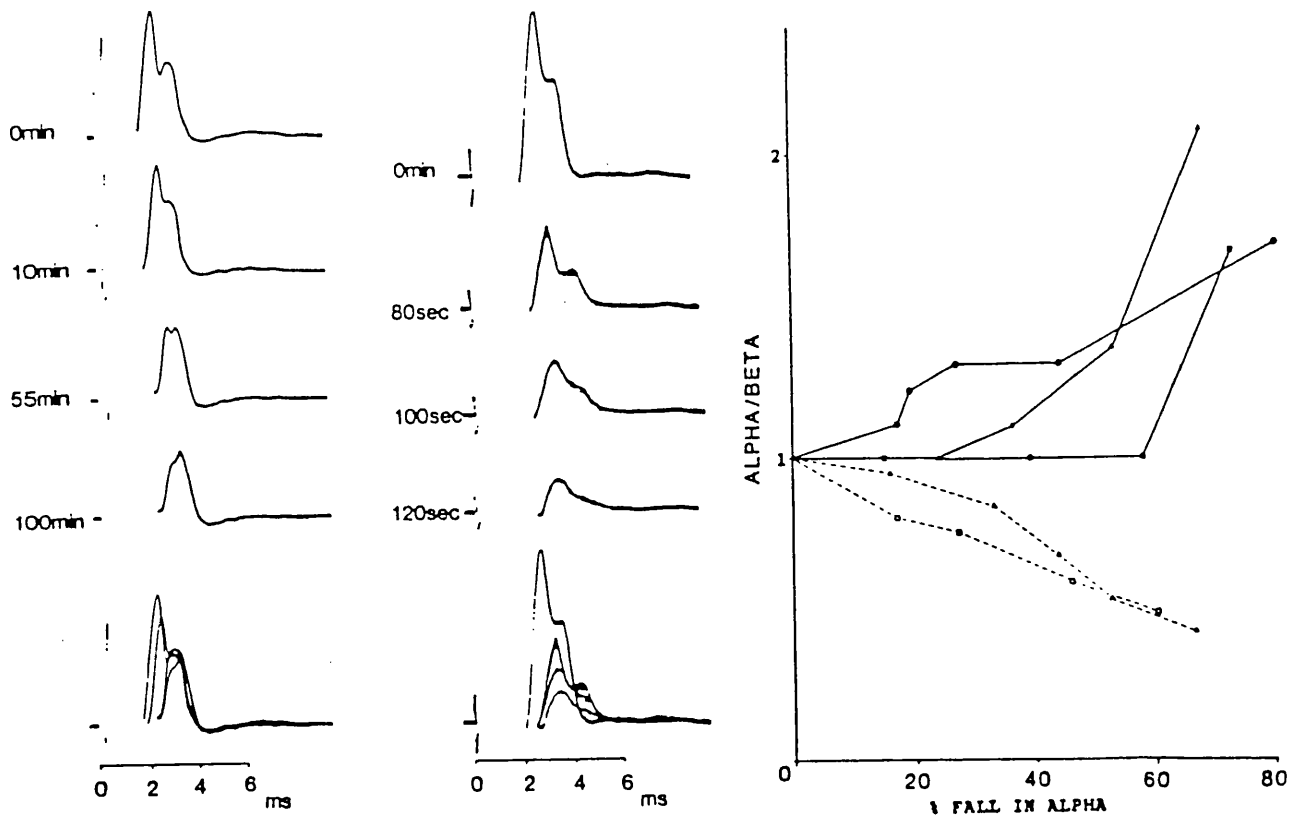

Figure 14

On the left are two series of compound action potentials. Control records (0 minutes) are shown at the top and in both cases a clear alpha/beta complex can be seen. As time following the onset of compression progresses, the amplitude of the compound action potentials is reduced. The two series of data have been superimposed at the bottom. In the case on the extreme left, in which a low degree of pressure is applied (100 mmHg), the alpha component (measured from baseline to the first peak or shoulder) appears to be affected more than the beta (measured from the baseline to the second peak or shoulder). To the right, in which a greater degree of pressure is applied (300 mmHg), the beta component appears to be affected to the greater extent. These records are superimposed at the bottom. On the far right, the ratio of the height of the alpha component divided by the height of the beta component is plotted against the fall in amplitude of the alpha component (normalised). Data for low (dashed line, $n=2$) and high (solid line, $n=3$) compression is shown. It should be noted that the value of such measurements of compound action potentials is limited

along the abscissa and a positive slope indicates differential suppression of the beta component. It is clear from this plot that the two degrees of compression do have different effects upon the compound action potential. As was found with unitary action potential recording, lower compression differentially affects the fast component while more severe compression differentially affects the slow component.

In chapter 8 the usefulness of such changes in compound action potential shape during conduction block are analyzed. The conclusion is drawn that qualitative differences in the conduction block produced by various conditions can be demonstrated using the compound action potential technique, indicating that these findings corroborate the unitary action potential data presented earlier.

3. c. DISCUSSION

Evidence presented in this chapter indicates that the characteristics of conduction block produced by deformation during compression depends upon the degree of compression applied. When 250 mmHg of pressure was applied to the nerve the order of failure of action potentials concurs with that deduced by Gasser and Erlanger (1929), with the fast, large diameter axons tending to block first. However, when 750 mmHg of pressure was applied the order of conduction block, although exhibiting a very great degree of scatter, was reversed and the slow, and therefore small diameter, myelinated axons tended to fail first. It would thus appear that one of the major factors affecting nerves during episodes of compression, ie. deformation, can have a more complex pattern of action than previously imagined.

3. c. 1. *Mechanism of conduction block at different degrees of compression*

When a segment of nerve trunk is compressed a pressure differential is established between the compressed and non-compressed regions of nerve. This pressure gradient acts to displace nervous material longitudinally. The work of Ochoa *et al.* (1971, 1972) has characterised the damage produced by nerve compression *in vivo*. These workers induced compression lesions in the medial popliteal nerve of the baboon. Histological analysis then revealed selective damage to large myelinated fibres, the damage being restricted to the edges of the compressed region. Damage was

characterised by displacement of nodes of Ranvier. From the time course of the compression (between 1-3 hours), and the predilection of damage to large fibres, it seems probable that similar changes underlie the conduction block induced by 250 mmHg of pressure in the current investigation.

However, under 750 mmHg of pressure it was found that the order of conduction block is reversed, with the slow myelinated axons tending to fail before the faster conducting axons. This must reflect a greater distress of the small axons under these conditions. If the conduction block produced by 250 mmHg of pressure involves the displacement of viscous material then 750 mmHg of pressure must have similar actions. However, possibly the greater forces acting under the higher compression produce a different pattern of axonal displacement, with disruption of axon-myelin junctions and translocation of myelin across the nodes of Ranvier, where lesser degrees of compression may only cause the displacement of myelin into the nodal gap.

Considering possible mechanisms that might account for the differential action of high compression upon smaller axons, one attractive possibility relates to the short length constant of these fibres. Small diameter axons have a short length constant for current flow along the axon due to a high resistance to longitudinal current flow, compared to current flow transversely across the membrane. One consequence of this is that the integrity of small axons needs to be compromised for only a short distance before conduction fails, an argument that has in the past been applied to explain the differential action of local anaesthetics (Franz and Perry, 1974).

When applied over a very short distance, however, the degree of compression will become less significant than in the current experiments. Thus, when the length of nerve being compressed is small compared to the length constant actions away from the nerve edges will become insignificant. This has been observed by Burke, Burne and Martin (1985) and Burke, Cottee, Garvey, Kumarasinghe and Kyriacou (1986) in the optic nerve. In these experiments high compression was applied over 1.5 mm length of nerve and produced specific block of large myelinated axons.

Similar conditions will exist in compression lesions generated by the application of a tight cord applied around a limb (Rudge, Ochoa and Gilliatt, 1974; Gilliatt, 1980 a), a model appropriate to mimic the sharply defined compression lesions sometimes encountered clinically. Such lesions conform to the acute type of compression

neuropathy, determined histologically (Rudge *et al.* 1974; Gilliatt, 1980 a). It is important to point out that the conduction block in such lesions will be distinct from that found during high compression over a longer length of nerve in the current experiments.

That compression can block small axons differentially appears to contradict the results of Weiss and Hiscoe (1948) and Luttges (1973). These authors showed that when model nerves, constructed from bundles of rubber tubes of varying diameter, are compressed, deformation is most prominent amongst the larger tubes. Moreover, on theoretical grounds, MacGregor, Sharples and Luttges (1975), also concluded that large fibres are most susceptible to compression. These models, however, are all dependant upon free displacement of intra-axonal material. Considering that axonal constituents are highly viscous, these models are inappropriate for situations where changes occur over a time course which does not allow significant axonal displacement.

3. c. 2. *Scatter in the order of conduction block*

A consistent finding in these experiments was the large degree of scatter in the size-dependant order of conduction block during compression. Scatter was not a simple result of experimental error as the order of conduction block in axons within single nerves did not always conform to the general order of conduction block as determined by pooling of data from many nerves. This must reflect the presence of factors, other than diameter, which are important determinants of an axons susceptibility to compression.

There might be many such factors contributing to the susceptibility of an individual axon to compression. Amongst these, perhaps the most significant will be the location of an axon within the nerve trunk. Axons located deep within the trunk will be cushioned from compression by both connective tissue and by those axons more superficially located. Evidence that the deeper axons are protected from compression in this manner comes from mechanical models (Weiss and Hiscoe 1948, Luttges 1973), and *in vivo* studies (Causey 1948; Aguayo *et al.* 1971; Moddel, Best and Ashby, 1977; Spinner and Spencer, 1974).

Another factor contributing to the variation must relate to differences in morphology between axons of similar diameter (Sunderland, 1978; Landon, 1982).

Thus, even if all axons were compressed uniformly a strictly size-dependant order of block seems unlikely. It is not surprising, therefore, that relationships between survival time and initial conduction velocity are scattered under all the conditions that have been tested (Paintal, 1965 a; Franz and Iggo, 1968; Franz and Perry, 1974). The additional factor of non-uniform cushioning of axons must account for the greater degree of scatter observed in the current experiments, compared to these earlier studies. Thus, when similar techniques to those used in this chapter are applied to investigate nerve ischaemia in chapter 4 a similar degree of scatter to that found in previous reports (ie. Paintal, 1965 a; Franz and Iggo, 1968; Franz and Perry, 1974) is found.

3. c. 3. *Comparison with previous findings*

The results obtained in this chapter allow block by nerve deformation to be divided into two distinct classes. Under low compression large axons are blocked first and conduction failure takes some time to develop. Under higher compression the slower axons block first and block occurs rapidly. In light of these categories it is possible to re-examine previous findings.

Denny-Brown and Brenner (1944 b), found that when compression was applied via a mercury filled bag to *in vivo* cat nerve, 760 mmHg caused conduction block within 120 seconds. Following release, recovery was complete within six minutes. Causey and Palmer (1949) applied 200-400 mmHg of direct mercury pressure over 1 cm of *in vivo* rabbit nerve and saw a rapid block within 20 minutes (average). Rapid recovery was observed. These two reports, in which a high degree of compression produces a rapid block, are compatible with the high compression block described in our experiments and would seem to suggest that this form of block is temporary rather than permanent.

Applying 130-200 mmHg of pressure over 20-40 mm Bentley and Schlapp (1943 b) observed conduction failure after 2.5-3 hours. Recovery was not apparent after a further 3 hours, and the block was located at the edges of the compressed region. These authors report that: "The first part of the "A" wave declined more rapidly than the last ... though a complete separation of the fast and slow fibres was not seen."

Gelfan and Tarlov (1956) compressed 5 mm of dog sural nerve such that it took 41-62 minutes for block of the compound action potential. Only a partial recovery was

found after a further 152 minutes. The author's concluded that the faster fibres were blocking first. Gasser and Erlanger (1929), applied 10 and then 25 psi over 12 mm of toad nerve and saw extensive block of the compound action potential after 30 minutes. A clear differential block was observed with the fast component of the "A" wave declining before the slower components.

All of the above reports, indeed all previous electrophysiological studies of nerve compression, have relied upon the compound action potential recording technique. The current findings are in broad agreement with these studies, confirming as it does that most forms of compression are likely to result in a differential conduction block of fast myelinated axons. A new form of compression block has also been identified, however, occurring when rather extreme compression is applied to the nerve, probably only occurring when this degree of compression is applied over a significant length of nerve, and apparently being reversible.

3. c. 4. *Relevance of current findings*

Finally, the importance that these two forms of deformation induced conduction block may have to the clinical situation needs to be assessed. It seems very probable that the block we have found during 250 mmHg of pressure, and which is presumably associated with the type of structural changes found in other animal models, is what is commonly found during acute compression lesions observed clinically.

Higher compression, if applied for long periods, will undoubtedly produce extensive damage to fibres. That a different form of conduction block has been found to be associated with higher degrees of compression may indicate that lesions resulting from very severe episodes of compression involve a pattern of damage different to that which has previously been reported. It must be borne in mind, however, that it cannot be concluded that 750 mmHg of pressure will produce specific damage to small axons if applied for a long period.

Possibly the most important finding in this chapter, therefore, has been the demonstration that the pattern of conduction block produced by the deformation associated with any but the most severe degree of compression, in the absence of ischaemia, conforms with that found in animal models of clinical disorders associated with compression and including ischaemia. This result seems to corroborate the view

that such disorders, arising from relatively severe compression, are the result of deformation of the nerve rather than from nerve ischaemia.

CHAPTER 4**THE EFFECT OF ISCHAEMIA UPON NERVE CONDUCTION**

4. a. INTRODUCTION

In the introduction to Section I it was pointed out that there is evidence for the involvement of both nerve deformation and nerve ischaemia in the conduction block produced by nerve compression *in vivo*. This point was taken up in chapter 3 in which the conduction block produced by deformation, in the absence of ischaemia, was investigated. This approach is continued in the current chapter in which a model of pure nerve ischaemia is described and the effect of ischaemia upon nerve fibres with different conduction velocities is characterised.

It is clear, however, that a study of the effects of nerve ischaemia upon axons of different conduction velocities, and therefore diameters, is timely for other reasons. In particular, the role of nerve ischaemia has been highlighted in a number of neurological disorders including; carpal tunnel syndrome (Lundborg *et al.* 1982; Gelberman *et al.* 1981, 1983; Powell and Myers, 1986; Kalichman and Myers, 1991), spinal root entrapment (Olmarker, 1990), peripheral nerve necrosis following embolism (eg. Lachance and Daube, 1991), muscle compartment syndrome (eg. Hargens *et al.* 1979) and a number of less common disorders (see: Eames and Lange, 1967; Harriman, 1977).

Despite the prevalence of nerve ischaemia pathologically the existing scientific literature is unclear regarding the effect of ischaemia upon nerve conduction in fibres of different sizes and functions. Some studies indicate that slowly conducting myelinated axons are more susceptible to ischaemia (Gasser, 1943; Hershey and Wagman, 1966; Fox and Kenmore, 1967; Dahlin *et al.* 1989), while others report that fast conducting nerve fibres tend to fail first (Lewis *et al.* 1931; Magladery *et al.* 1950). The first series of studies base their conclusions upon changes observed in compound action potential shape, a technique which is not reliable for the detection of differential nerve block unless corroborated by single unit recordings (see chapter 8).

In the studies of Lewis *et al.* (1931) and Magladery *et al.* (1950) ischaemia was induced by the application of a tourniquet to the limb, a procedure which, largely due to these studies, has become a standard method of reputedly producing a differential block of fast myelinated axons in man (Moddel *et al.* 1977; Jaeger, Gottlieb, Agarwal and Tahmoush, 1982; Gottlieb, Agarwal and Jaeger, 1983; Cody, Goodwin and

Richardson, 1987; Davies, 1987). However, the discrepancy remains that the compound action potential data of Gasser (1943), of Hershey and Wagman (1966), of Fox and Kenmore (1967) and of Dahlin *et al.* (1989), is in conflict with the results of Lewis *et al.* (1931) and of Magladery *et al.* (1950), thereby undermining the methodological basis of these investigations. Since all the previous studies of nerve ischaemia have used indirect approaches (ie. changes in perception, in compound action potentials or in electromyographic recordings), in the current chapter the direct technique of recording unitary action potentials is applied during the ischaemia which follows cardiac arrest.

Cardiac arrest, and the whole body "global" ischaemia which follows, was selected, from a number of possible models, as the least problematical method of producing rapid ischaemia of peripheral nerve. As will be discussed (page 81), the induction of global ischaemia allows the conduction of multiple action potentials to be monitored during ischaemia without contaminating results with any physical deformation of the nerve.

4. b. RESULTS

Results were obtained in two separate series of experiments. The initial seven experiments were performed on cats which had previously been employed to investigate a different matter. Thus, these seven animals, having endured no additional surgical procedures but having up to an eight hour delay following surgery before recordings were begun, and being paralysed with gallamine, provided considerable data but of a less refined form. For example, recordings were often in the nature of semi-compound, multi-unit, potentials where up to a dozen action potentials were elicited in individual spinal rootlets. Such recordings do not always allow the conduction of distinct action potentials to be monitored accurately, and thus contain an element of experimental error. Data from this series of experiments will be presented at the end of the results section.

The results shown in the first part of the results section are taken from a second series of experiments performed upon two cats. These experiments were performed for the sole purpose of this project and recordings were of a more precise nature, with an average of only 1.4 unitary action potentials being recorded from each nerve rootlet.

In addition, following the experiments the peripheral nerves were dissected out to allow the accurate measurement of their length. Despite this more careful analysis no significant differences were found between the two sets of data.

4. b. 1. *Dedicated experiments*

Figure 15 shows two series of data organised in sequential chronological order. The records are taken from the same dorsal root filament; on the left following stimulation of the sural nerve and on the right following stimulation of the nerve branch to flexor digitorum longus (FDL). Sural nerve stimulation produces two unitary action potentials which follow the large stimulus artifact. Stimulation of the FDL nerve branch produces a smaller artifact followed by a single unitary action potential.

Control records were taken for 35 minutes before cardiac arrest was induced and sample records, taken at various times during this period, are shown in Figure 15. The conduction velocity of the action potentials remains stable over this control period. Following cardiac arrest (time zero, indicated by a dashed line in Figure 15), the conduction latency of the action potentials can be seen to increase in subsequent records. In the series following sural nerve stimulation, the slower potential (initial conduction velocity=34 m/sec) disappears from the record after 17 minutes and 40 seconds as the axon undergoes conduction failure. The remaining faster potential (initial conduction velocity=45 m/sec) fails after 27 minutes and 50 seconds. In the series of records following stimulation of the FDL branch, the single potential (initial conduction velocity=70 m/sec) fails after 35 minutes and 10 seconds.

Thus, these three unitary action potentials are failing in the order of conduction velocity; slowest action potentials first. However, recording from any single spinal root, it was obvious that this relationship was not strictly adhered to and that sometimes the faster action potential of a pair would fail first.

In order to assess the general pattern in the sequence of conduction failure during ischaemia, the data relating to stimulation of different nerve branches and recorded from a single spinal root filament were pooled. Figure 16 shows plots of survival time against initial conduction velocity for the unitary action potentials recorded from two ventral and two dorsal root filaments, plotted separately. Regression lines (method of least squares error) have been fitted to the data. It can be seen from

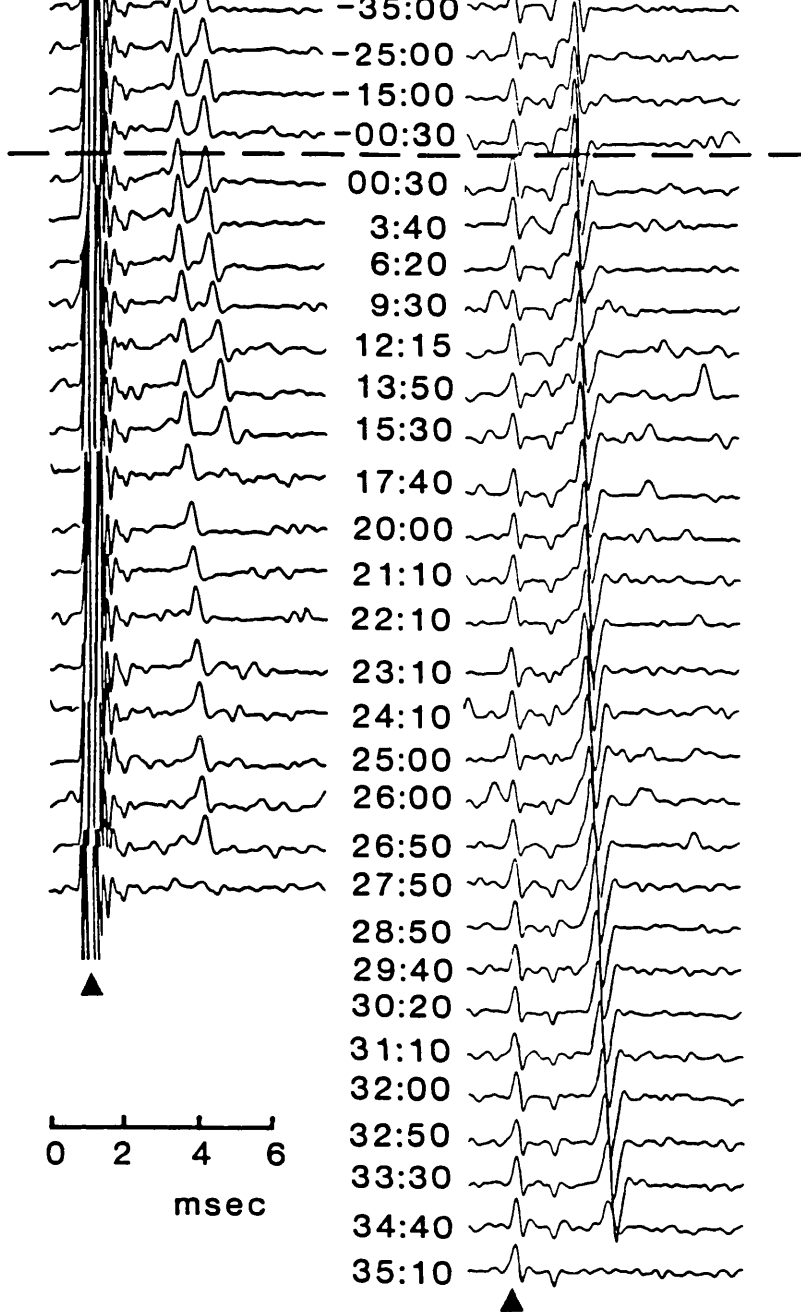

Figure 15

Two series of records taken from the same dorsal root filament following stimulation of peripheral nerve branches. On the left, two action potentials are recorded following stimulation of a branch of the sural nerve. They arrive at the recording electrode with different conduction latencies as they have different conduction velocities. On the right a single action potential is recorded following stimulation of a branch to FDL. The three potentials have stable conduction velocities over the 35 minute control period before cardiac failure is induced. In the subsequent records the potentials undergo conduction slowing and eventually conduction block. Cardiac failure is induced at time zero which is indicated with a dashed line. The stimulus artifacts are indicated with arrow heads.

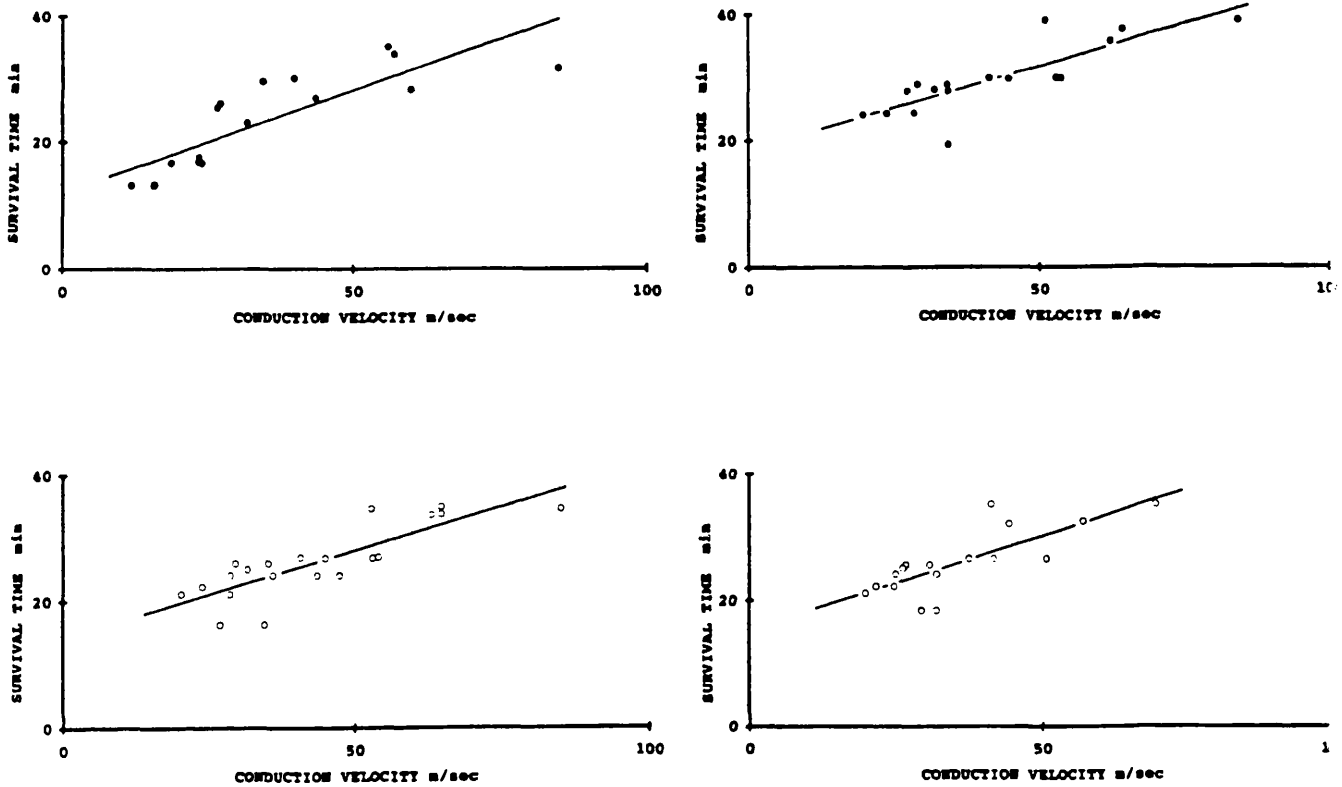

Figure 16

Plots of survival time against initial conduction velocity for action potentials recorded from four spinal root filaments. The two panels on the left are from one cat and on the right from another. Filled circles are action potentials recorded from ventral root filaments, open circles from dorsal root filaments. Regression lines (method of least squares error) have been fitted to the data ($P < 0.001$ in all cases), confirming the clear tendency for the slow conducting axons to fail before the fast conducting axons.

this that the slow conducting axons tend to block before the fast conducting axons in all four cases.

Figure 17 is a plot of survival time against conduction velocity for all 96 action potentials recorded from dorsal root filaments. The data have been fitted by a best fit line ($r=0.76$, $P<0.001$) which confirms the clear tendency for the slow sensory axons to fail before the fast sensory axons, following cardiac arrest. The average survival time is 24.8 minutes (average conduction velocity=35.3 m/sec).

The survival times of all 68 action potentials recorded from ventral root filaments is plotted against conduction velocity in Figure 18. A regression line ($r=0.72$, $P<0.001$) has been fitted. This plot also reveals an ordered sequence of conduction failure, with the slow motor axons tending to fail before the fast. The average survival time is 24.1 minutes (average conduction velocity=33.7 m/sec).

Comparison between the data for sensory and motor axons indicates that while the relationship between these variables might appear different in the two types of axons (the regression line for motor axons being steeper than that for sensory axons, see Figure 18), it is not significantly different at the 5% level (t-test).

Non-dedicated experiments

As has been mentioned, the initial experiments were performed before dedicated experiments were designed. The main shortfalls of the initial experiments are that more action potentials were recorded from each nerve rootlet and that conduction distances were not accurately established by dissection. This suggests that the results described in this section may contain a greater element of experimental error.

Figure 19 (top) is a plot of initial conduction velocity against survival time for 92 action potentials recorded from ventral root filaments. Figure 19 (bottom) is a similar plot for 112 action potentials recorded from dorsal root fibres. It can be seen that in the plots of both the sensory and the motor data the slow conducting fibres fail before the fast fibres. Again it is found from a linear regression analysis that the relationship for the motor data is steeper than that for sensory data, although this also is not statistically meaningful at the 5% level.

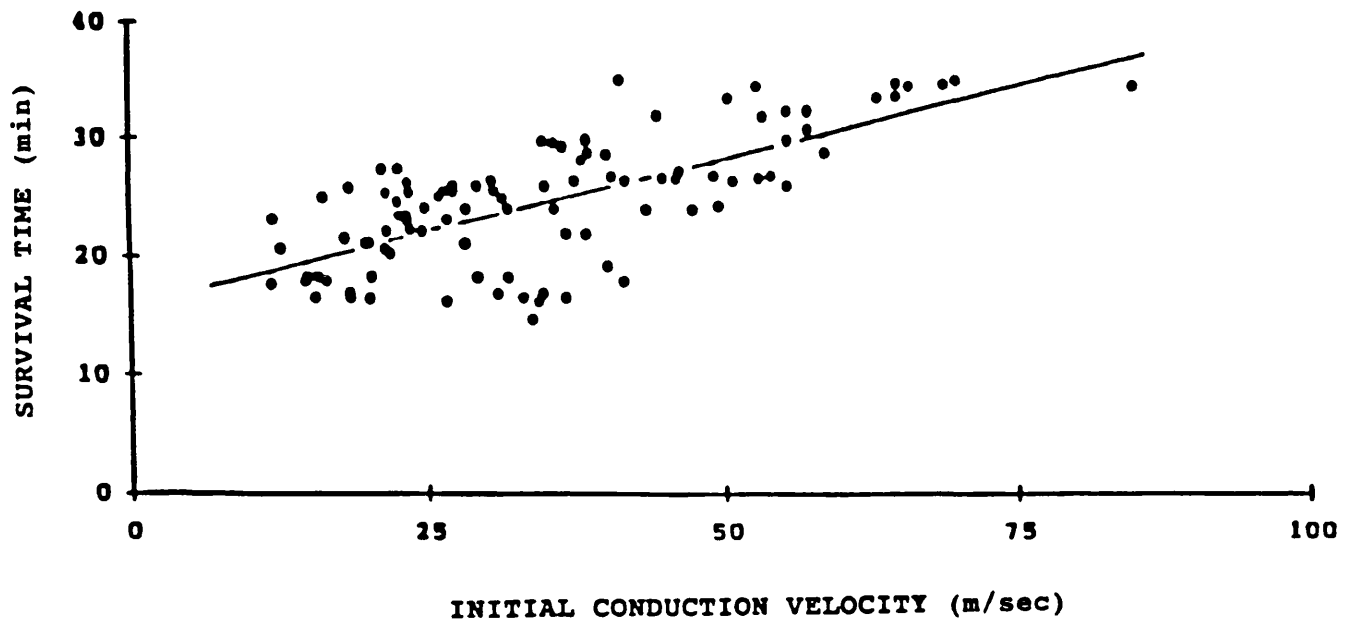

Figure 17

Plot of survival time against initial conduction velocity for 96 sensory axons (regression line $r=0.76$, $P<0.001$). There is a clear tendency for the slow axons to fail before the fast axons.

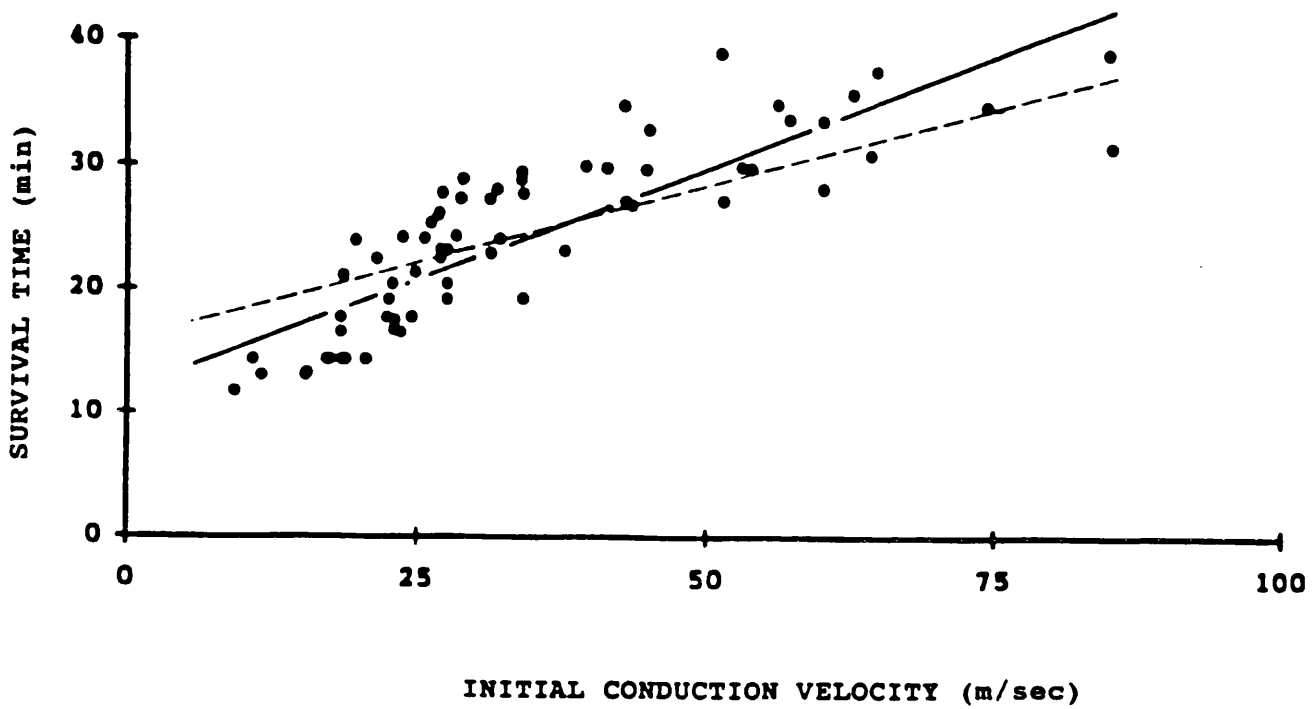

Figure 18

Plot of survival time against initial conduction velocity for 68 motor axons. A regression line has been fitted ($r=0.72$, $P<0.001$). The regression line for the sensory axons has been included on the motor axon plot (dashed line).

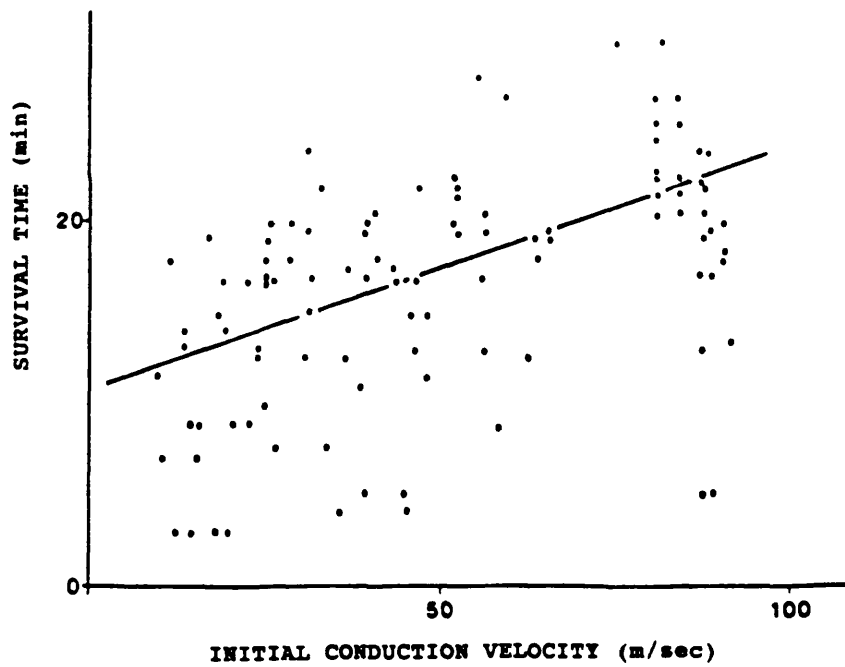
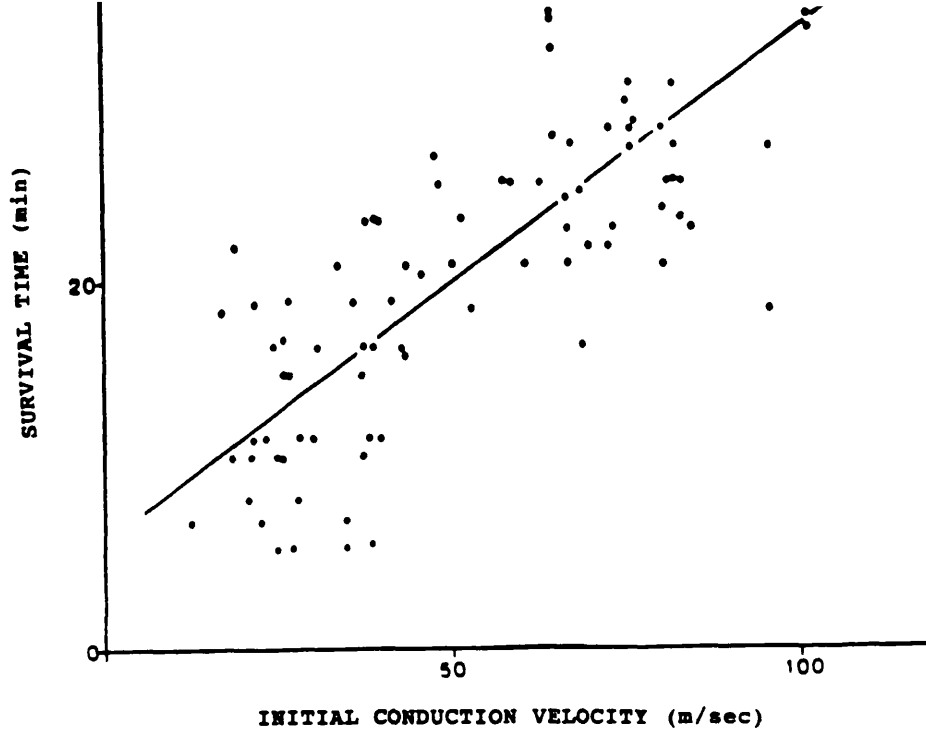

Figure 19.

Plots of survival time against initial conduction velocity. Top, data from 92 motor axons (linear regression $r=0.76$, $P<0.001$). Bottom, data from 112 sensory axons (linear regression $r=0.52$, $P<0.001$). In both cases the slow axons tend to fail before the fast axons.

4. c. DISCUSSION

The present chapter has shown that as ischaemia develops following cardiac arrest, slow conducting myelinated axons tend to fail before fast conducting myelinated axons, with all axons blocking between 11 and 39 minutes (in the dedicated experiments, which must represent the more accurate set of data). By comparison, compound action potential studies of cat nerve report survival times of 29 (Lehmann, 1937) and 33 minutes (Wright, 1946) during anoxia, and 28 (Frankenhaeuser, 1949) and 30 minutes (Bentley and Schlapp, 1943 a) during ischaemia.

Previous studies of the effect of ischaemia or anoxia upon nerve conduction have largely been based upon recordings of compound action potentials (Lehmann, 1937; Bentley and Schlapp, 1943 a; Gasser, 1943; Wright, 1946; Fox and Kenmore, 1967; Okada and McDougal, 1971; Dahlin *et al.* 1989). In general, these studies describe a suppression of a slow component of the compound action potential before a fast component. This has led the authors to conclude that slow conducting myelinated axons have a low resistance to ischaemia, which is in agreement with the results of the present investigation.

In contrast to these reports, Lewis *et al.* (1931) monitored the decay of sensory and motor transmission in the human arm during limb ischaemia. Based partly upon the observation that conduction in non-myelinated fibres was retained for long periods, these workers concluded that all slowly conducting axons, both myelinated and non-myelinated, have a high resistance to ischaemia. However, it has since been demonstrated that non-myelinated axons are better adapted for survival during anoxia than are myelinated axons (Ritchie, 1967), which results in non-myelinated axons having a disproportionately high resistance to ischaemia (Torebjörk and Hallin, 1973; Dahlin *et al.* 1989). Thus, conclusions based upon observations on non-myelinated fibres cannot be extrapolated to the population of myelinated fibres.

4. c. 1. *The "global" ischaemia model*

Frankenhaeuser (1949) investigated a number of techniques for generating ischaemia of the sural nerve of the rabbit. Comparing local ischaemia produced by leg

amputation and the whole body ischaemia produced by clamping the trachea, Frankenhaeuser found no significant difference in nerve conduction survival time. He concluded that substances released during the cardiac distress which follows tracheal clamping have no significant effect upon ischaemic survival time.

Frankenhaeuser (1949) also found that surgical incisions through the skin open a pathway for oxygen diffusion to nearby nerves. This had the effect of extending considerably the ischaemic survival time near incision sites. To overcome this problem Frankenhaeuser applied a tourniquet to the hind limb to isolate the recording site from the rest of the leg. A tourniquet, however, must involve some deformation of the underlying nerve structure (eg. see Hess, Eames, Darveniza and Gilliatt, 1979) and recent studies indicate that this tourniquet deformation either does (Yarnitsky and Ochoa, 1989), or does not (Bostock, Baker, Grafe and Reid, 1991 a) influence nerve conduction. Whichever, as a pure model of nerve ischaemia was desired in the current chapter tourniquet methods are clearly inappropriate. A whole body "global" ischaemia model was therefore selected.

The tracheal clamp method used by Frankenhaeuser (1949) is a workable model of ischaemia and a similar model has been used more recently by Dahlin *et al.* (1989). The major concern with such models lies in the release of substances (eg. catecholamines), following drastic changes in blood pressure, which might influence nerve conduction, notwithstanding the findings of Frankenhaeuser (1949) which indicate that this does not influence ischaemic survival time. However, in an attempt to minimise this factor the most rapid fall possible in blood pressure is desired, limiting the translocation of substances from the body to the peripheral nerves. Sudden cardiac arrest must be the fastest means of halting the circulation and this approach was therefore employed.

The major alternative method for inducing nerve ischaemia is ligation of the sciatic nerve blood supply. However, peripheral nerves have a very rich network of supply vessels (Rechthand and Rapoport, 1987; Lundborg, 1988; see also page 48). These vessels tend to branch upon entry into the nerve trunk, forming a plexus running the length of the nerve, an arrangement which provides a high safety factor for nerve perfusion. As a result various studies have reported that it is either very difficult, or impossible, to make a peripheral nerve ischaemic by ligating its local vascular supply

(Bentley and Schlapp, 1943 a; Roberts, 1948; Blunt and Stratton, 1950; Blunt, 1960; Lundborg, 1970, 1975, 1988).

Ligation of major blood vessels some distance from the sciatic nerve trunk (eg. both the abdominal aorta and the femoral artery) can produce a reliable model of ischaemic neuropathy (Korthals and Wisniewski, 1975; Hess *et al.* 1979). However, considering that nerves receive a significant amount of oxygen from surrounding muscles (Bentley and Schlapp, 1943 b), a rapid ischaemic conduction block is unlikely to occur.

The cardiac arrest "global" ischaemia model therefore has a number of advantages for the current study. It produces a very rapid and absolute nerve ischaemia, the region of nerve becoming ischaemic (ie. between the leg pool and the back pool) is not mechanically disturbed in any way, and spinal nerve roots are readily accessible allowing recording from identified motor and sensory axons. The major disadvantage lies in the inability to investigate recovery from ischaemia and the possibility that substances not normally released in the periphery during ischaemia will reach the nerve prior to complete circulatory breakdown. With reference to this last point it is known that muscles release significant quantities of catecholamines during normal activity (Esler, Jennings, Leonard, Sacharias, Burke, Johns and Blombery, 1984) and that catecholamine concentration may well rise steeply during limb ischaemia anyway.

4. c. 2. *Ischaemia in clinical conditions.*

Ischaemia has been implicated in several forms of peripheral neuropathy, in particular in chronic nerve compression (Lundborg *et al.* 1982; Lundborg, 1988; Gelberman *et al.* 1981, 1983; Powell and Myers, 1986), in compartmental syndromes (Hargens *et al.* 1979), following arterial occlusion (Lachance and Daube, 1991) and in diabetic neuropathy (Elliott, 1971). The role of ischaemia in chronic compression is less clear than in compartmental syndromes, following occlusion or in diabetic neuropathy. However, chronic compression is often associated with a differential loss of sensory function, compared to motor function (eg. Gilliatt and Thomas, 1960; Morris and Peters, 1976). Considering that loss of function in small myelinated axons will affect sensory perception without significantly affecting motor function, the current results suggest that this would be expected if nerve ischaemia is an important factor in chronic

compression block.

4. c. 3. *Possible mechanism underlying the pattern of conduction block during ischaemia.*

The conduction block produced by ischaemia may be a result of extracellular potassium accumulation (Shanes, 1951). While potassium does not readily accumulate within the node of Ranvier (Okada and McDougal, 1971; Rydmark and Berthold, 1983), it is thought that potassium may accumulate in the periaxonal space between the internodal myelin and the axolemma (Ritchie, 1985; Bostock *et al.* 1991 a, b; David, Barrett and Barrett, 1992). One consequence of this will be a depolarisation of the internodal axolemma, and a depolarisation of the node of Ranvier due to electrotonic spread of charge. This phenomenon is expected to affect the smaller axons to a greater degree (Chiu and Ritchie, 1984; Ritchie, 1985), as small myelinated axons have a high nodal membrane resistance. From this it can be expected that during ischaemia, axonal survival time will be related to axonal diameter and hence conduction velocity. This is precisely the relationship found in the current experiments.

In arriving at this theoretical prediction, it is necessary to take account of the relationship between nodal membrane area and axon diameter, as determined by Rydmark and Berthold (1983). Rydmark and Berthold described the relationship between these two variables as being steeper for motor axons than for sensory axons. If this is the case then it would be expected that sensory and motor fibres would exhibit differences in their sensitivity to ischaemia. However, while the relationship between survival time and conduction velocity is steeper for motor than for sensory axons in both series of experiments described in the results, as predicted, this difference is not significant at the 5% level in either set of data.

4. c. 4. *Ischaemia as an experimental tool.*

In recent years a number of investigations have been performed in which a limb tourniquet has been used as a method of producing a differential nerve block (eg. Moddel *et al.* 1977; Jaeger *et al.* 1982; Gottlieb *et al.* 1983; Cody *et al.* 1987; Davies, 1987). Conduction block induced in this manner is thought to be largely ischaemic,

rather than mechanical, in origin (Lewis *et al.* 1931; Frankenhaeuser, 1949; Hayashi *et al.* 1987; Bostock *et al.* 1991 a; but see Yarnitsky and Ochoa, 1989). Partly based upon the findings of Lewis *et al.* (1931) and partly upon the work of Gasser and Erlanger (1929), these workers have interpreted their results on the basis that a limb tourniquet produces a differential block of large myelinated axons. Our findings indicate however, that this procedure will, in fact, produce a differential block of small myelinated axons. It would appear that observations, interpretations and conclusions made in these investigations need to be reassessed.

CHAPTER 5

THE CONTRIBUTION OF ISCHAEMIA AND DEFORMATION TO THE
CONDUCTION BLOCK GENERATED BY COMPRESSION OF NERVE *IN VIVO*

5. a. INTRODUCTION

Clinical disorders associated with compression of the nervous system are rather common. This has led to a comprehensive investigation of neuronal compression including histological, electrophysiological and clinical examination of various animal and human models (Denny-Brown and Brenner, 1944 a, b; Fullerton and Gilliatt, 1967 a, b; Anderson *et al.* 1970; Ochoa *et al.* 1971, 1972; Fowler *et al.* 1972; Ochoa and Marotte, 1973; Rydevik and Nordborg, 1980; Gelberman *et al.* 1981, 1983; Powell and Myers, 1986; Lundborg 1988; Dahlin *et al.* 1989; Olmarker, 1990). These studies have provided detailed information regarding the changes in nerve structure and function which follow compression but have left doubts regarding the fundamental causes of such changes.

One major cause of functional loss during nerve compression is undoubtedly the purely mechanical deformation of nerve structure. Thus, during relatively severe compression the nodes of Ranvier of myelinated fibres actually become displaced away from the compressed region (Ochoa *et al.* 1971, 1972). In addition, the compressed nerve also becomes ischaemic as blood flow through nutritive vessels is occluded (Gelberman *et al.* 1981, 1983; Rydevick *et al.* 1981; Lundborg *et al.* 1982; Matsumoto, 1983; Ogata and Naito, 1986). Indeed, ischaemia might be the essential factor in some forms of nerve compression disorders (Hargens *et al.* 1979; Lundborg *et al.* 1982; Powell and Myers, 1986; Kalichman and Myers, 1991) and has a pattern of effect consistent with that found in some types of compression disorder (see chapter 4). Uncertainty exists, therefore, regarding the relative importance of nerve deformation and ischaemia during compression and whether the nature of the compression is important in this regard.

In the previous two chapters the pattern of action of nerve deformation and nerve ischaemia have been investigated separately. These experiments revealed that these two components of *in vivo* compression have contrasting actions upon the nerve fibre population. In the current chapter pressure has been applied to the cat sciatic nerve via an inflatable balloon, with two degrees of pressure being employed. The lower pressure (70 mmHg) is in the range of pressures associated with chronic nerve compression disorders such as carpal tunnel syndrome (Gelberman *et al.* 1981). In

contrast, the more severe compression (250 mmHg) is more likely to be associated with clinically acute compression accidents. It was hoped that studying the pattern of action of these two degrees of nerve compression might allow some correlations to be drawn with the data of the previous two chapters.

5. b. RESULTS

Figure 20 (left) shows the response of unitary action potentials recorded from a dorsal root filament to the application of 70 mmHg of pressure to the sciatic nerve trunk. Prior to the onset of compression (time zero) five action potentials can be seen to follow the stimulus artifact (arrows have been used to indicate the action potentials). Over a period of 48 minutes following the application of compression these potentials disappear from the records in an all or nothing manner. Thus, over the first 19 minutes of compression little change is evident in the records. By 28 minutes however, the second, third and fifth fastest conducting potentials have all disappeared from the record (block of action potentials has been marked with stars). By 37 minutes the fastest action potential has also blocked and by 48 minutes conduction of all action potentials has failed.

It can be seen from Figure 20 that some conduction slowing occurs prior to conduction block, although the extent of conduction slowing is much less than that observed in the compressed frog nerve (chapter 3), and the ischaemic cat nerve (chapter 4). This can be explained by the limited length of the compressed region in the present study, as a fraction of the total conduction distance. Thus, any increase in conduction latency within the compressed length of nerve will be only a small proportion of the total conduction latency.

In Figure 20 (right) the survival time of these potentials is plotted against their initial conduction velocity. The data is scattered with no underlying pattern being evident. Figure 21 shows a similar plot of 62 action potentials recorded from a total of three cats. This reveals clearly that the slow conducting axons are the most susceptible to this degree of compression. A linear regression line has been drawn ($r=0.70$, $P<0.001$). Average survival time is 55.7 minutes (range 5-120 minutes), with an average conduction velocity of 45 m/sec (range 17-86 m/sec).

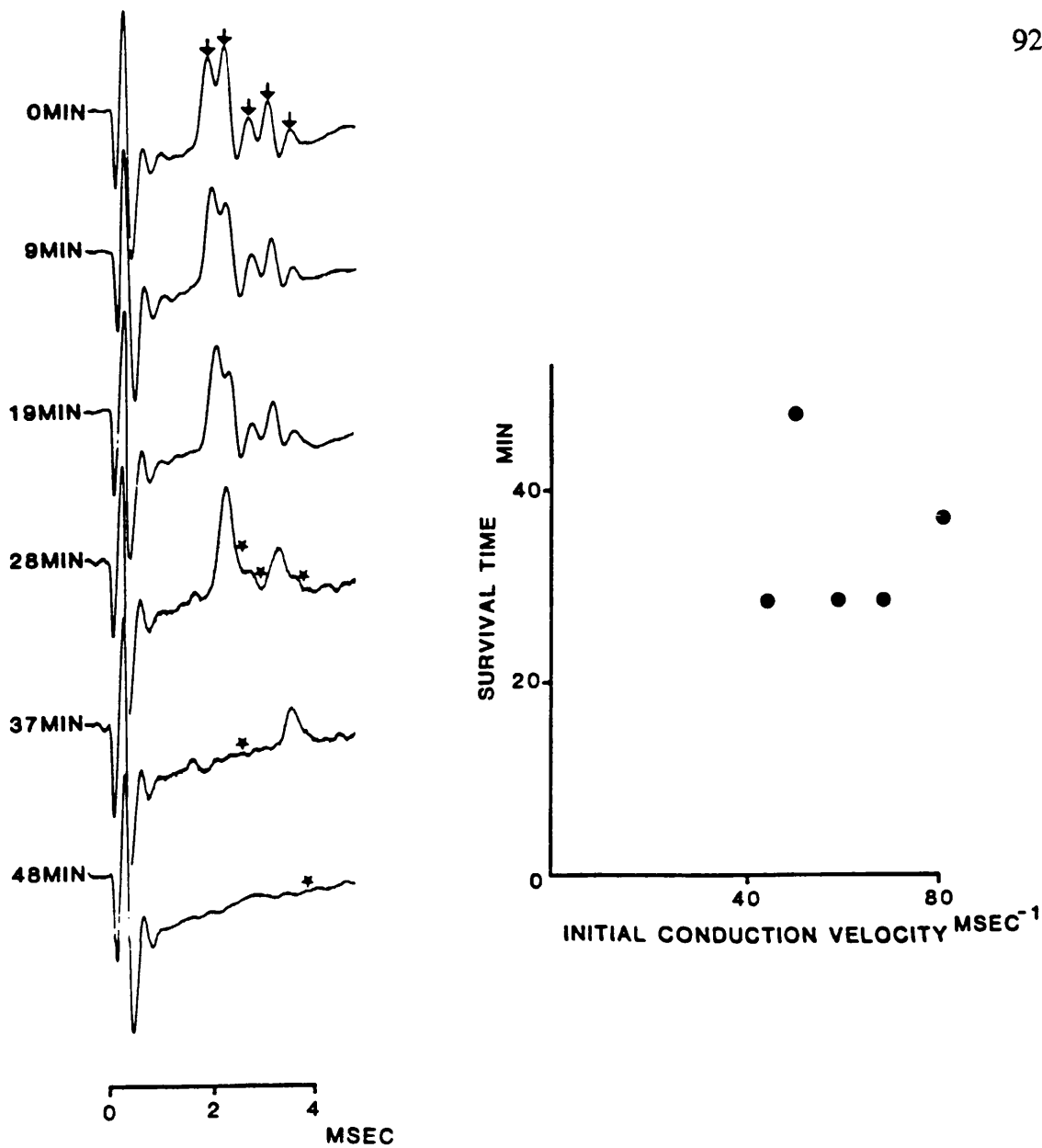

Figure 20

On the left, recordings taken from a dorsal root filament following stimulation of the FDL nerve. Six traces are shown which demonstrate, in descending chronological order, the effect of 70 mmHg pressure of the sciatic nerve trunk upon conduction of action potentials. On the right, the data is plotted with survival time between onset of compression and conduction block against initial conduction velocity. The plot reveals that there is no correlation between survival time and initial conduction velocity in this example.

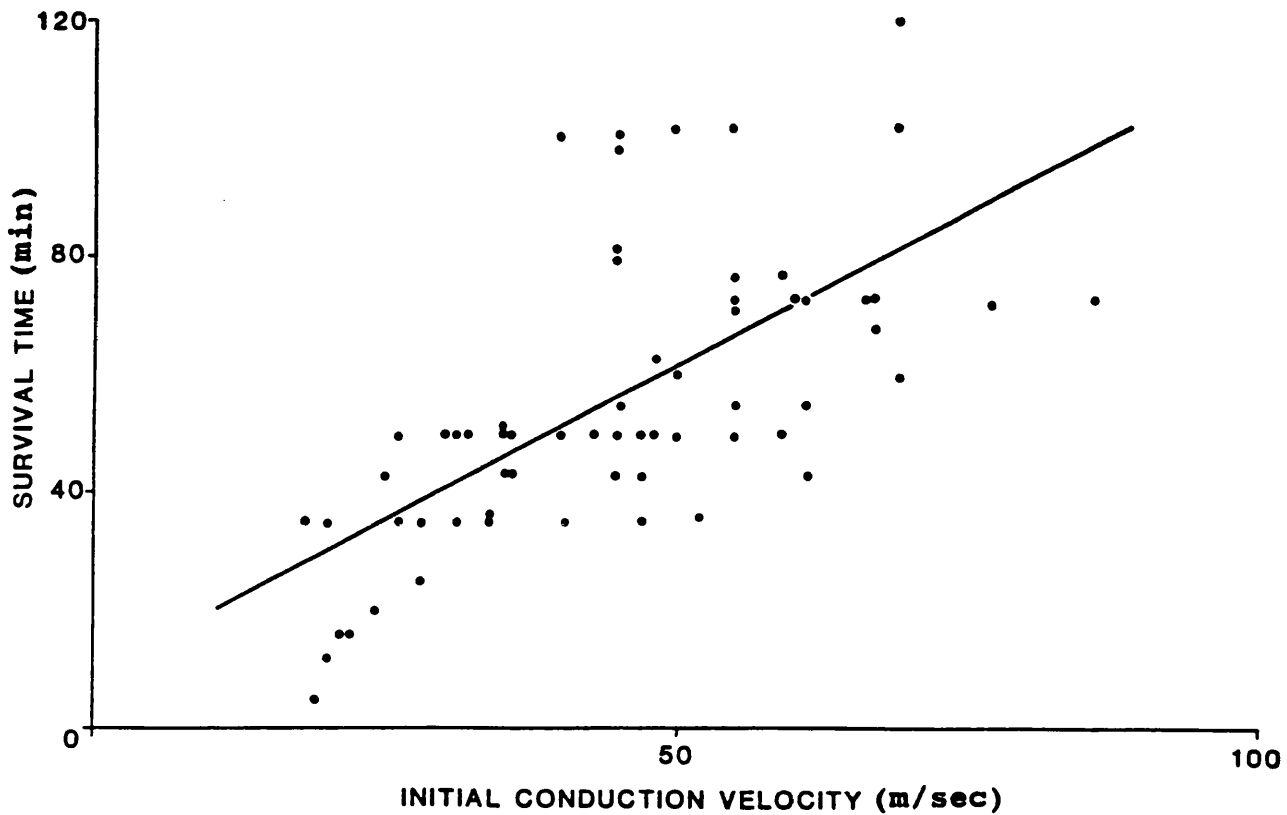

Figure 21

Plot of survival time following the onset of 70 mmHg pressure against initial conduction velocity for 62 action potentials from 3 cats. A regression line (method of least squares error) has been fitted to the data ($r=0.70$, $P<0.001$). There is a clear tendency for the slow conducting axons to fail before the fast conducting axons.

Figure 22 is a plot of survival time following the onset of 250 mmHg of pressure against conduction velocity for 226 action potentials recorded from four cats. A clearly different pattern of conduction block is revealed to that found during 70 mmHg of pressure. Thus, there is a much larger degree of scatter in the data than at 70 mmHg of pressure and, in addition, the regression line demonstrates that the fast conducting axons tend to fail before the slow axons in these experiments ($r=-0.23$, $P<0.001$). The average survival time is 35.0 minutes (range=2.5-95 minutes), and the average conduction velocity is 55.9 m/sec (range=13-89 m/sec).

The relationship between survival time and conduction velocity following the application of 250 mmHg of pressure contains a far greater degree of scatter than that following application of 70 mmHg of pressure. It is possible that the large diameter and multi-fascicular nature of the cat sciatic nerve may be a factor contributing to this scatter. Thus, axons deep within the nerve may be cushioned from the compressing force, as suggested in chapter 3. In order to investigate this possibility, an analysis was performed of those occasions where many axons were carried from individual nerve branches to the spinal roots. These axons will tend to run close together in the sciatic nerve trunk (Sunderland, 1978) and will therefore experience a similar degree of cushioning.

Figure 23 is a histogram constructed from data obtained in nine experiments where 14 or more unitary action potentials were recorded from the dorsal roots following stimulation of a single nerve branch. The number of action potentials recorded from the dorsal roots has been plotted against the correlation coefficient of survival time against initial conduction velocity for those particular units (from linear regression analysis). This shows that action potentials carried from the FDL, tibial and common peroneal nerves have an order of conduction block with very low correlation coefficients, not approaching statistical significance. All of these nerves are of large diameter, containing approximately 3000, 6000, and 2500 myelinated axons respectively (Boyd and Davey, 1968). However, the sural, medial gastrocnemius and plantaris nerves are of much smaller diameter, containing only 750-800 myelinated axons (Boyd and Davey, 1968). In these nerves, a clearer pattern of conduction block is found, with two of the four examples having correlation coefficients of statistical significance at the 5% level.

Figure 22

250 mmHg pressure experiments. Top: The slope of the regression analysis for survival time against initial conduction velocity for the nine nerve branches with the most number of unitary potentials. The arrow represents the slope of the regression analysis performed upon all the data. Bottom: Plot of survival time following the onset of 250 mmHg pressure against initial conduction velocity for 256 sensory axons, regression line $r=-0.23$, $P<0.001$. Under this more severe compression there is extensive scatter in the data but a tendency for the fast conducting axons to fail before the slow conducting axons.

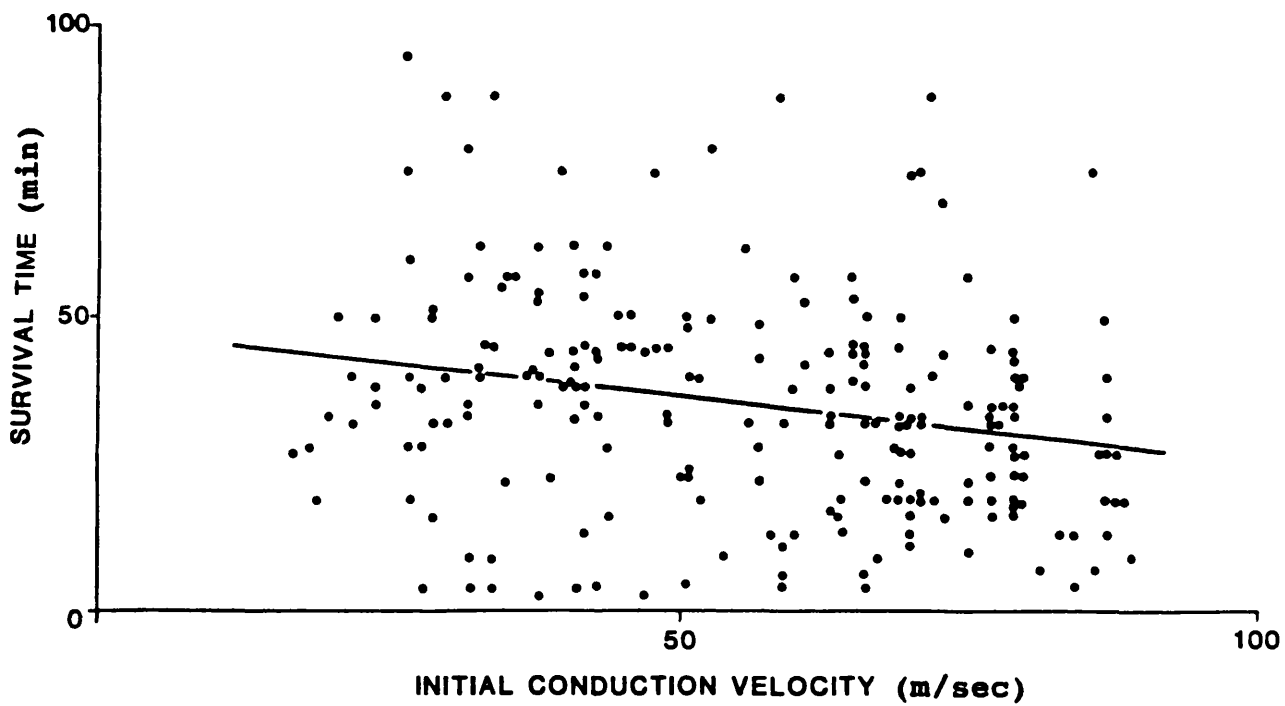
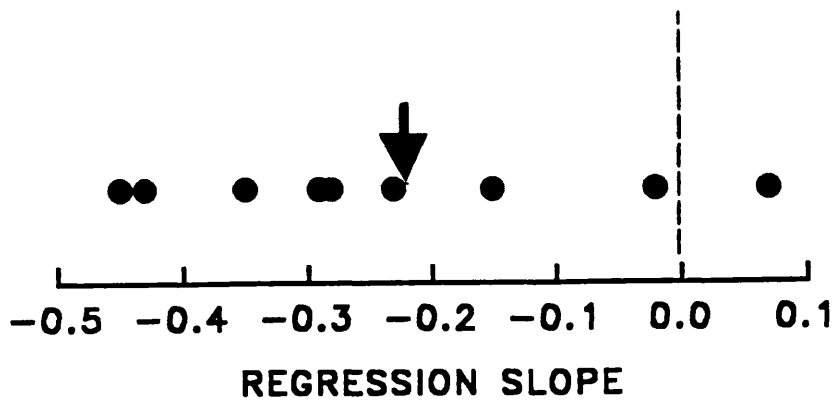

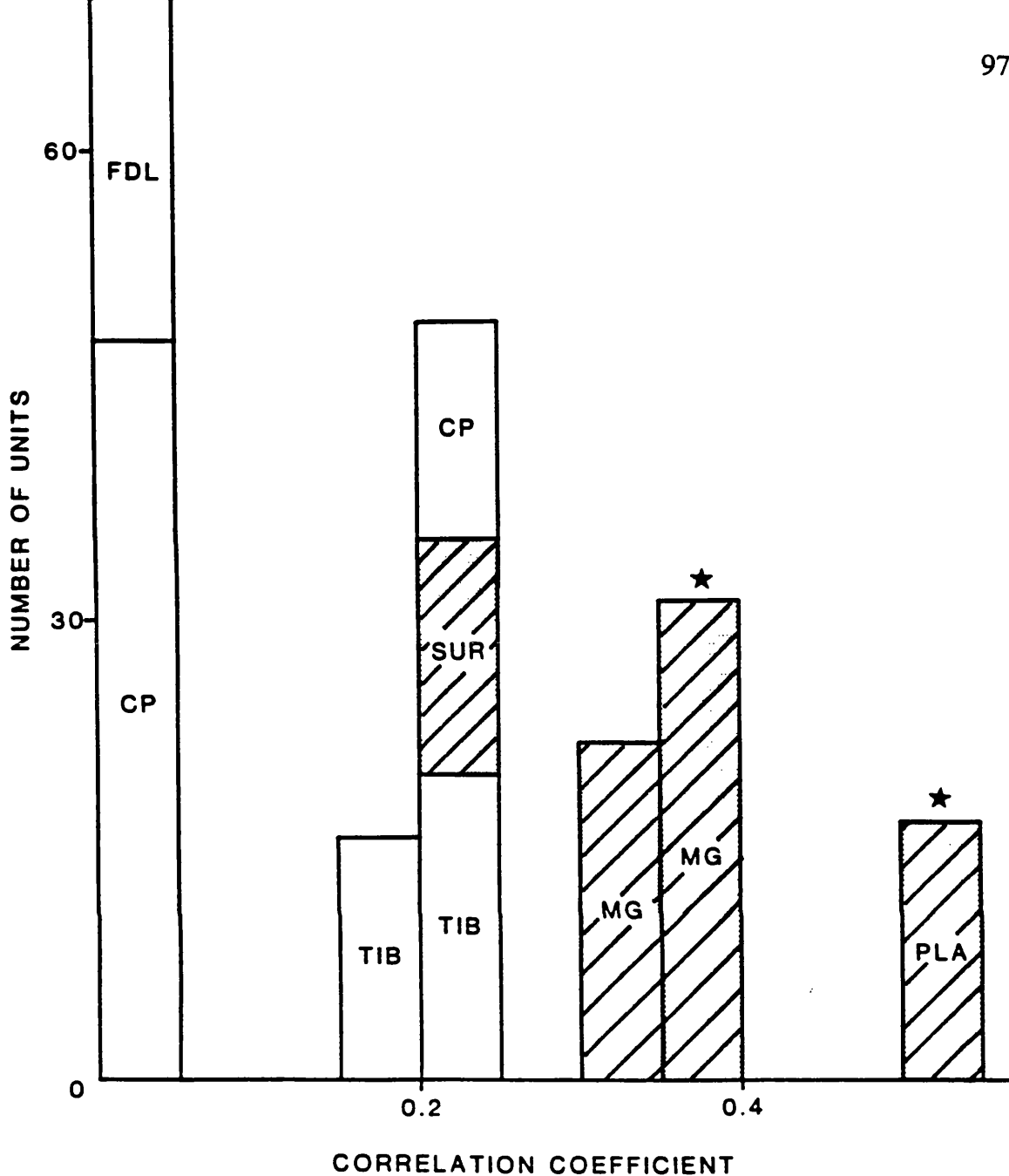

Figure 23

Histogram showing data from experiments where 14 or more action potentials were recorded following stimulation of a single peripheral nerve during 250 mmHg pressure. The number of potentials recorded is plotted against the correlation coefficient of the relationship between survival time and initial conduction velocity. Action potentials recorded from the CP, FDL and TIB nerves have low correlation coefficients. Action potentials from the sural, MG and PLA (shaded) nerves have higher correlation coefficients, with two examples being significant at the $P < 0.05$ level (indicated with stars).

That axons entering the sciatic nerve trunk in small branches appear to have a more sequential order of conduction block than those entering in large branches indicates that axons scattered throughout a large nerve branch are not uniformly affected by compression. A proportion of the scatter in the order of conduction block observed during compression resulting from 250 mmHg of pressure is thus likely to be a result of the spatial scatter of nerve fibres throughout the sciatic nerve trunk.

5. c. DISCUSSION

The results obtained in this chapter show that the characteristics of conduction block induced by nerve compression *in vivo* are dependant upon the degree of compression applied. Thus, when 70 mmHg of pressure is applied to the nerve action potential conduction blocks within an average of 53 minutes, with the slow conducting axons tending to fail before the faster conducting axons. In contrast, 250 mmHg of pressure produces conduction block with an average of 35 minutes and the fast conducting axons tend to block first. In addition, 70 mmHg of pressure produces a pattern of conduction block with a relatively low degree of scatter, while the time course of action of 250 mmHg of pressure is less well correlated with axon conduction velocity. Indeed, the primary characteristic of the effect of the higher degree of compression is the scatter in the data.

5. c. 1. *Scatter in the order of conduction block.*

Although a statistically meaningful correlation is found, the data from the 250 mmHg of pressure experiments in this chapter are very widely scattered. As has been pointed out in chapter 3, scatter in the order of conduction block generated by deformation of fibres will inevitably result if the sampled axons are randomly distributed within the nerve trunk. This follows from the demonstration in mechanical models that axons located superficially within a nerve are less well cushioned from deformation than those located centrally (Weiss and Hiscoe, 1948; Luttges, 1973).

The results indicate that action potentials carried from a single small nerve branch have a less scattered order of conduction block than action potentials carried from large nerves branches containing multiple sub-branches. If we assume that axons

entering the sciatic nerve in a small branch will tend to course closer together compared to those entering in a large branch (cf. Sunderland, 1978), then it seems likely that the distribution of axons throughout the nerve trunk contributes markedly to the scatter in the order of block observed. However, considering the time course of the conduction block found during compression resulting from 250 mmHg of pressure the effects of ischaemia may also be contributing to the scatter. The converse may also be true, with a measure of deformation adding scatter to the order of conduction block at 70 mmHg of pressure. That the average time to conduction block during the two degrees of compression are separated by only 18 minutes suggests that some overlap in the action of 70 and 250 mmHg of pressure is occurring.

5. c. 2. *Basis of conduction block under mild and severe compression.*

As the characteristics of conduction block produced by 250 mmHg and 70 mmHg of pressure of the cat sciatic nerve are so different it seems likely that they result from different fundamental causes. Figure 24 shows plots of data taken during deformation of the frog nerve (chapter 3), ischaemia of the cat nerve (chapter 4), and 70 mmHg and 250 mmHg pressure of the cat nerve (this chapter). If we accept that the only likely causes of conduction block during compression *in vivo* are deformation and ischaemia (see introduction to Section I) it seems reasonable to correlate these four sets of data. Thus, both the compression resulting from 70 mmHg of pressure and ischaemia have a differential action upon slow conducting myelinated axons, with a relatively low degree of scatter (high correlation). 250 mmHg of pressure and nerve deformation are typified by a low correlation between these two parameters and an underlying tendency for the fast myelinated axons to fail first. I propose, therefore, that conduction block produced by lower degrees of compression are generated via local ischaemia of the nerve while under more severe compression deformation of nerve structure becomes more important in the progression of nerve conduction failure.

It is noteworthy that the plot of data from the 250 mmHg experiments indicates a similar survival time for both fast and slow myelinated fibres, despite the underlying tendency for a relationship between survival time and conduction velocity. This is no doubt due to the inevitable involvement of ischaemia during the higher degree of compression, notwithstanding the prime importance of deformation. Thus, deformation

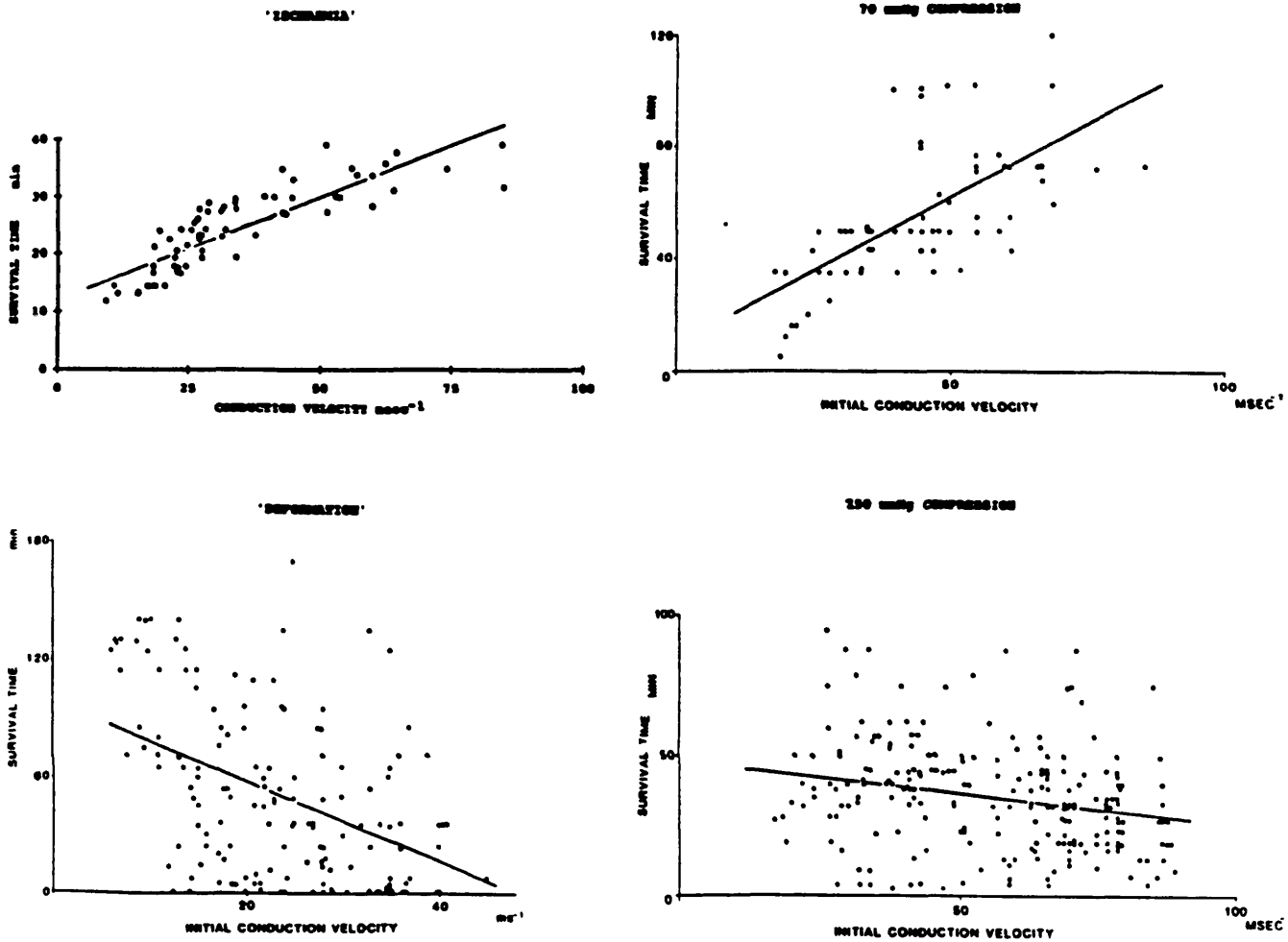

Figure 24

Four plots of survival time against initial conduction velocity during; ischaemia of cat sensory axons (top left), deformation of the isolated frog nerve (bottom left), 70 mmHg pressure of *in vivo* cat nerve (top right), and 250 mmHg pressure of *in vivo* cat nerve (bottom right).

produces a pattern of conduction block which is contrary to that produced by ischaemia under 250 mmHg of pressure, although ischaemia must be acting under that degree of compression.

5. c. 3. *Relevance for clinical compression disorders.*

That the compression resulting from 70 mmHg and 250 mmHg of pressure produces conduction block via different mechanisms suggests that the conduction block found in the various clinically recognised nerve compression disorders, which are known to result from different degrees of compression, may have separate causes.

In the current chapter it was found that a degree of pressure in the middle of the range associated with chronic compression disorders (70 mmHg) produces a pattern of conduction block that is similar to that found during ischaemia (chapter 4). Furthermore, this was dissimilar to that found in acute nerve compression animal models (Ochoa *et al.* 1971, 1972) and during pure deformation of nerve (chapter 3). This is good supporting evidence that ischaemia, rather than deformation, underlies the conduction block experienced during chronic compression disorders.

The pattern of conduction block produced by 250 mmHg of pressure was found to contrast with that resulting from ischaemia. This more severe degree of compression in fact produced a pattern of conduction block comparable with that found during deformation (chapter 3), and similar to that found in previous models of acute nerve compression disorders (Ochoa *et al.* 1971, 1972). Thus, the present investigation indicates that conduction block associated with acute compression disorders results mainly from deformation of the nerve, a distinctly different causal relationship to that apparently occurring in chronic compression disorders.

An important caveat to these deductions is that they cannot easily be extrapolated to long term conduction block during compression. Thus, new factors might come into play after longer periods of compression, for example nerve oedema (Lundborg, 1988), which are unlikely to have a major influence during the short compression times employed in this study. Such factors might be particularly important in chronic compression disorders as the raised pressures associated with chronically compressed nerves often persist for many months. It is worth noting, however, that in at least one model of long term nerve ischaemia a differential loss of small myelinated axons was

found (Parry and Brown, 1982).

5. c. 4. *A note on tourniquet palsy*

The degree of pressure employed to generate acute compression block in this chapter (250 mmHg) can be applied to human nerves via a tourniquet for long periods without generating permanent conduction block. Thus, tourniquet pressures of this level are regularly employed during hand surgery without ill effect (eg. Yates, Hurst and Brown, 1981; Lundborg, 1988). Furthermore, pressures far greater than those used to generate acute compression block in the current chapter were required by Gilliatt and co-workers to induce acute lesions in the *in situ* baboon nerve (Ochoa *et al.* 1971, 1972; Gilliatt, 1980 a). Despite this, workers employing isolated or exposed nerves have reported that lower degrees of compression generate conduction block with acute characteristics (Bentley and Schlapp, 1943 b; Dahlin *et al.* 1989; Fern and Harrison, 1991 a).

Relatively low compression has also been shown to have pathological effects upon the vasculature of exposed nerve (Rydevik and Lundborg, 1977), which would be pathological if it occurred during tourniquet in man. It therefore appears that peripheral nerves *in situ* can tolerate higher pressures before developing acute compression lesions than can exposed or isolated nerves. That nerves might be cushioned from the compressing force when *in situ* cannot explain the apparent resilience of *in situ* nerves; thus in the work on baboon nerve it was established that pressure did not fall off significantly within the limb as a result of cushioning (Rudge, unpublished observation in Gilliatt, 1980 a; and see Crenshaw, Hargens, Gershuni and Rydevik, 1988).

In addition, because the site of the acute lesion is at the edges of the compressed region the different lengths of nerve compressed during the various protocols cannot explain the variation in pressures which result in acute lesions. The likely explanation does, however, lie with the edge effect nature of the acute compression lesion. When pressure is applied directly to an exposed nerve the difference in pressure between the compressed and non-compressed region will change in a step-wise manner. The pressure gradient will therefore be very steep and axonal components will be displaced by relatively low degrees of pressure.

However, when compression is applied through the muscles and connective

tissues of a limb the pressure gradient at the edges of the compressed region will be more gradual. Thus, although the absolute pressure effecting the nerve may be high, the pressure gradient experienced by the nerve may not be significant. As was originally explained by Gilliatt and co-workers, absolute pressure is not relevant in nerve compression, while pressure gradients are. Consequently it is not surprising that greater degrees of pressure need to be applied before acute lesions are produced.

This observation may indicate a means of reducing the occurrence of tourniquet palsy following surgery. Thus, a layer of padding around the limb, or some other means of producing a diffuse compression, while not having any great effect upon the induction of ischaemia, will diminish the gradients of pressure at the edges of the cuff. Tourniquet palsy has proved to be a consistent problem with tourniquet application (Sunderland, 1978; Lundborg, 1988), affecting between 1 in 5000 (Middleton and Varian, 1974; Yates *et al.* 1981) and 1 in 750 (Flatt, 1972) patients. The persistent occurrence of this problem has encouraged the use of wider tourniquet cuffs, which produce a more uniform compression and allow the use of lower absolute pressures (Muirhead and Newman, 1986; Hargens, Skyhar, McClure, O'Hara, Lieber, Gershuni and Akeson, 1987; Moore, Gartin and Hargens, 1987; Crenshaw *et al.* 1988). Supplementing this development with the current suggestion may produce an additional advance in technique.

CONCLUSIONS TO SECTION I

In Section I a number of experiments have been performed of a similar type. Action potentials have been recorded from axons, the functioning of which has been compromised experimentally. The conduction velocity of the action potentials has then been correlated to the ability of axons to survive under these experimental conditions. The ultimate aim of this has been to relate the experimental regimes with important clinical events.

As in most scientific investigations the original complex problem has been simplified by attempting to isolate the variables. Thus, nerve deformation was studied in the absence of ischaemia, and nerve ischaemia was studied in the absence of deformation. When nerve compression was then studied using an *in vivo* model this allowed some interpretation of the data to be made.

It is hoped that this analysis suggests an answer to the much discussed question of nerve compression neuropathy aetiology which reconciles much of the previously obtained data. Thus, reputable studies can be quoted that strongly indicate ischaemia as the fundamental cause of acute and chronic compression disorders, while other equally reputable references indicate that it is deformation which underlies both of these events (see introduction to Section I).

It has been shown in Section I that the pattern of conduction block during ischaemia parallels that found during chronic compression while the conduction block found during deformation parallels that found during acute compression. This finding has been proposed previously (Sunderland, 1978; Gilliatt, 1980 a, b; Lundborg, 1988). The contribution of this study has been to show the contrasting effects of ischaemia and deformation and severe and mild compression in a single series of studies, as has not been achieved before.

SECTION II

**CONDUCTION BLOCK IN FROG MYELINATED
AXONS**

INTRODUCTION TO SECTION II

The function of the nerve fibre is the rapid transmission of information from one region of the body to another. This is achieved by the interaction of electrically passive and electrically active regions of the nerve fibre. Transient deviations in membrane potential are generated by ionic conductance changes at nodes of Ranvier and are transmitted electrotonically along the internodal regions, which constitute the vast majority of the axon's length. The axon can therefore be thought of as an exquisitely designed biological cable containing regions which periodically renew the voltage signal, preventing the loss of information content.

Assessing and interpreting the experimentally induced breakdown of this process has provided a lot of information about the normal conduction of action potentials in axons. A great deal of information has also been reported pertaining to experimental models of clinical conditions involving loss of function in axons. Some experiments of this type are described in section I of this thesis.

Recent developments have highlighted new areas of study in nerve fibres. A fresh emphasis has been placed upon the internodal region of the axon, with a variety of ionic conductances and a previously unrecognised current pathway being found (Baker Bostock, Grafe and Martius, 1987; Black, Kocsis and Waxman, 1990; David, Barrett and Barrett, 1992). All of the consequences of these discoveries have yet to be evaluated, in particular in light of clinical practices and pathological conditions. For example, the newly recognised importance of the internodal region suggests that axons may have more complex responses to changes in their ionic environment than previously thought. Thus, some initial observations indicate that two functionally important axon compartments are not equally open to the penetration of potassium ions (Barrett and Barrett, 1982; Chiu, 1982), while high extracellular potassium has profound effects upon neurones and is common in the nervous system (Waltz and Hertz, 1983; Dietzel and Heinemann, 1986).

In addition, theoretical considerations based upon new histological data suggest that very small myelinated axons may have a low safety factor for action potential conduction (Chiu and Ritchie, 1984). This possibility has been only poorly investigated in the past, but has distinct relevance as it may explain the analgesic properties of local

anaesthetics.

In section II of this thesis these questions are addressed employing the isolated, perfused, frog nerve preparation. Individual action potentials have been recorded and the time course and extent of changes in conduction velocity assessed following changes in the ionic environment surrounding the axons. In addition, an appraisal of the compound action potential as an alternative recording technique is presented.

Historical background

The structure of the axon is arranged to maximise the speed at which the action potential is transmitted. The ratio of the resistance for current flow out of the axon, ie. across the axon membrane (R_m), compared to the resistance to current flow along the axon interior (R_i), will determine how a voltage signal falls off with distance along the axon (length constant $\lambda = R_m/R_i$). The rate at which a voltage signal in the axon is diminished with time will depend upon the product of the capacitance of the axon membrane (C_m) and the membrane resistance (time constant $\tau = C_m \cdot R_m$). Ideally, therefore, the axon should have a low longitudinal resistance, a high membrane resistance and a low membrane capacitance (Katz, 1966; Aidley, 1978; Jack, Noble and Tsien, 1975; Stämpfli and Hille, 1976; Tasaki, 1982).

The longitudinal resistance of an axon is inversely proportional to its cross sectional area, and as a result the ideal axon should have a large diameter. However, as was pointed out by Rushton (1951), evolutionary forces will determine how much space in the body can be appropriated by axons. The diameter of axons can not, therefore, be increased beyond a certain point. As a consequence the axon's structure is arranged to optimise membrane resistance and membrane capacitance. In myelinated axons the presence of the myelin sheath, a high resistance, low capacitance layer that coats the axon over most of its length, contributes greatly in accomplishing this goal.

The myelin sheath is formed from tightly apposed and compacted lamellae (Landon, 1982), and in the frog has a resistance of approximately 100-275 $K\Omega/cm^2$ and a capacitance of approximately 0.004 $\mu F/cm^2$ (Huxley and Stämpfli, 1949; Tasaki, 1955). These values compare to 1-5 $K\Omega/cm^2$ for resistance and 1 $\mu F/cm^2$ for capacitance for membranes of giant non-myelinated axons (Hodgkin, Huxley and Katz, 1952; Katz, 1966; Binstock and Goldman, 1969). Thus, myelinated axons have a 100 fold greater

specific membrane resistance and 200 fold smaller specific membrane capacitance than non-myelinated axons.

The myelin coating is separated approximately every 2 mm by nodes of Ranvier, which are the sites of greatest voltage dependant sodium channel density in frog axons (Chui and Ritchie, 1982; Grissmer, 1986). The resting membrane potential of the frog axon is largely governed by the transmembrane potassium ion concentration (Huxley and Stämpfli, 1951 b). The opening of sodium channels at the node of Ranvier drives the membrane potential away from the potassium reversal potential and towards the sodium reversal potential, producing an action potential with an amplitude of approximately 116 mV (Huxley and Stämpfli, 1951 a).

Sodium channel opening is brief and membrane potential quickly returns to the resting state, aided by an increase in potassium conductance (Dodge and Frankenhaeuser, 1958, 1959; Frankenhaeuser, 1960, 1962, 1963 a, b; Frankenhaeuser and Huxley, 1964). In the classical model of action potential conduction these conductance changes are restricted to the axolemma of the node of Ranvier and are triggered by the electrotonic flow of current following a potential change at a neighbouring node of Ranvier.

However, a number of studies published over the last ten years have suggested that the internodal region of the axon is more than a simple pathway for current flow between nodes of Ranvier. During the action potential, for example, some current appears to flow beneath the myelin sheath in the periaxonal space. This current flow generates a significant depolarising after-potential (Barrett and Barrett, 1982; Blight, 1985; Blight and Someya, 1985; Baker *et al.* 1987; Barrett, Morita and Scapaticci, 1988; Bostock, Baker, Grafe and Reid, 1991; Bostock, Baker and Reid, 1991; David, Barrett and Barrett 1992). Histological examination had earlier revealed the presence of a large periaxonal space beneath the myelin (Berthold, 1978) and a morphological correlate for this current does, therefore, exist.

That the structure-function relationship of the myelinated axon is more complex than once thought, and that the internodal region plays an important role in modulating action potential conduction, is also indicated by the variety and heterogeneous distribution of axonal ion channels. Thus, in addition to the sodium conductance, a slow potassium conductance, two types of fast potassium conductance and an inward

rectifying conductance have all been identified. The various types of conductance display a divergent range of distributions within the nodal, paranodal and internodal axolemma.

In the node of Ranvier of the frog Dubois (1981), has found both a slow activating, non-inactivating potassium conductance (G_{ks}) and a fast activating, slow inactivating potassium conductance (G_{kf}). The proportion of the total potassium conductance made up by slow channels was approximately 20%, with the remaining 80% being of the fast variety. The fast conductance could be decomposed on the basis of activation potential into two further components, indicating the presence of two sub-populations of fast potassium channels (G_{kf1} and G_{kf2}).

Chiu and Ritchie (1982) reported the presence of potassium channels in the internode of the frog, which have since been characterised by Grissmer (1986). Slow potassium current was found to constitute 33% of the total internodal potassium conductance, compared to 15% in the node, but the majority of the potassium conductances in both the node and the internode was in the form of fast potassium conductance. The total potassium channel density was found to be 20 times lower in the internode compared to the node.

In addition to these three outwardly rectifying potassium channels Bostock and Grafe (1985) have found evidence for an inwardly rectifying conductance in the internode of the frog. A similar inward rectifying current in mammalian axons has been identified and probably carries both sodium and potassium ions (Baker *et al.* 1987; Eng *et al.* 1990).

These various frog myelinated axon potassium channels can be distinguished pharmacologically as well as electrophysiologically and spatially. Fast channels are blocked by 4-Aminopyridine (4-AP), slow channels are not (DuBois, 1981; Grissmer, 1986), while G_{kf2} can be specifically blocked by capsaicin (Dubois, 1982). Slow potassium channels are blocked by tetraethylammonia (TEA), but a significant TEA insensitive slow potassium conductance is present in the internode (Grissmer, 1986).

The functional roles of the various axonal potassium channels in mammalian axons has been evaluated pharmacologically. Thus, neither 4-AP or TEA has any great effect upon the amplitude or time course of the action potential in normal mammalian myelinated axons (Sherratt, Bostock and Sears, 1978, 1980; Bostock, Sears and

Sherratt, 1981; Kocsis, Gorbon and Waxman, 1986; Eng, Gordon, Kocsis and Waxman, 1988; Black *et al.* 1990). However, a TEA sensitive, 4-AP insensitive hyperpolarisation is found following periods of high frequency activity (Kocsis, Eng, Gordon and Waxman, 1987) and is important for axonal accommodation (Baker *et al.* 1987). While a 4-AP sensitive TEA insensitive conductance inhibits short bursts of action potentials (Baker *et al.* 1987).

It appears, therefore, that potassium channels function in a regulatory capacity in mammalian myelinated axons, acting mainly to modulate the transmission of trains of action potentials. Although similar studies have not been performed in the frog it has been shown that slow potassium channels are a prerequisite for accommodation in the frog axon (Krylov and Makovsky, 1978), and it is known that delayed potassium channels play an important role in action potential repolarisation (Frankenhaeuser and Huxley, 1964; Frankenhaeuser 1965).

Sodium channels also have a localised distribution within myelinated axons. Grissmer (1986) has found sodium conductance present in both the node and internode of the frog axon, although the sodium channel density was 500 times greater in the node. In mammalian axons a relatively larger internodal sodium conductance was found by Chiu and Ritchie (1987), although the suggestion was made that these sodium channels could have originated from the myelin sheath and were transferred to the axolemma by the experimental protocol employed (a similar protocol was used by Grissmer, 1986).

From this data it appears that the frog myelinated axon has a multi-compartment nature comprising nodes and internodes, both specialised to perform functions vital to normal action potential conduction. The various ionic channel types are distributed differently in these two regions, which is likely to reflect the differing roles played by these structures. The internode has been demonstrated to generate a late depolarising potential following the action potential, and is also important in generating action potential discharges in the post-ischaemic axon (Bostock *et al.* 1991 a, b). Much of the data collected in Section II of this thesis is interpreted in terms of this model of the frog myelinated axon. The data from frog axons is summarized in Appendix I, and compared to that from mammalian axons.

CHAPTER 6

**THE EFFECTS OF HIGH EXTRACELLULAR POTASSIUM UPON NERVE
CONDUCTION**

6. a. INTRODUCTION

In considering the mechanisms underlying conduction failure following ischaemia, a possible mechanism discussed (chapter 4) was the hypothesis that extracellular potassium accumulation might play a central role. Raised extracellular potassium has, in fact, been highlighted in a number of neurological conditions. These include; spreading depression (Kraig and Nicholson, 1978; Reddy and Bureš, 1980; Reid, Marrannes and Wauquir, 1988), epilepsy (Fertziger and Ranck, 1970; Moody, Futamachi and Prince, 1974; Heinemann, Lux and Gutnick, 1977; Waltz and Hertz, 1983), anoxia of white matter brain regions (Hansen, 1985; Ransom, Walz, Davis and Carlini, 1991), ischaemia of peripheral nerve (Shanes, 1951; Ritchie, 1985; Bostock *et al.* 1991 a, b), and spinal cord injury (Young, Koreh, Yen and Lindsay, 1982; Young and Koreh, 1986).

In addition, build up of extracellular potassium is known to influence the transmission of action potentials in axons under various physiological conditions. This occurs during post-ischaemic paraesthesia of peripheral nerve (Bostock *et al.* 1991 a, b) and following periods of high frequency activity in both peripheral nerve axons (Raymond, 1979; Hoppe, Chvatal, Kettenmann, Orkand and Ransom, 1991), and in CNS axons (Krnjević and Morris, 1973; Kocsis, Malenka and Waxman, 1983; Waltz and Hertz, 1983).

All of these studies have the common feature that they implicate high extracellular potassium in changes in the ability of axons to conduct action potentials. How high extracellular potassium will effect action potential conduction will depend upon the structure and membrane organisation of the axon, which is complex. For example, different regions of the axon have different types and distributions of ion channels, including three distinct potassium channel sub-types (Dubois, 1981; Chiu and Ritchie, 1981, 1982; Grissmer, 1986; Baker *et al.* 1987; Barrett, *et al.* 1988; Röper and Schwarz, 1989; Black, Kocsis and Waxman, 1990; Eng *et al.* 1990; David *et al.* 1992).

In addition, where axons pass through regions of high potassium compartments within the axon can not be expected to be uniformly open to the penetration of potassium ions. In particular, potassium is likely to penetrate more easily into the node

of Ranvier than into the periaxonal space (Barrett and Barrett, 1982; Chui, 1982). This is of particular interest considering the recently highlighted importance of the internodal region to nerve conduction (Barrett and Barrett, 1982; Blight, 1985; Blight and Someya, 1985; Baker *et al.* 1987; Barrett *et al.* 1988; Bostock *et al.* 1991 a, b; David *et al.* 1992).

In the present chapter myelinated frog sciatic nerve axons have been perfused with a high concentration of potassium ions while action potential conduction velocity has been monitored. This technique allows the time course of the action of potassium ions upon nerve conduction to be studied. The potassium channel blocker tetraethylammonium (TEA) has been employed to assess the role played by nodal and internodal potassium channels to the conduction slowing produced by high potassium. This makes use of a peculiarity of frog axons, that they have a significant TEA insensitive potassium conductance located within the internodal axolemma that is absent in the nodal axolemma (Grissmer, 1986). In addition, perfusion with other ionic solutions has been used to assess the contribution made to the results by diffusion barriers between the axons and the perfusate.

The methodology employed involves an isolated frog sciatic nerve preparation in which the majority of the nerve fibres and connective tissues have been removed over the perfused length (see methods). This procedure was performed to minimise diffusion barriers around the remaining axons.

Membrane potential changes following high potassium perfusion have been studied on a number of occasions in the frog myelinated axon (Huxley and Stämpfli, 1951 b; Ulbricht, 1981, 1983). The current methodology is of a somewhat different form. Thus, axon function has been monitored in largely intact axons. It was hoped that this approach would allow the functional consequences of high extracellular potassium ion concentration to be examined in a preparation where the morphological integrity of the nodal and internodal regions of the axon is assured.

6. b. RESULTS

6. b. 1. *High potassium perfusion*

Following initial experiments a standard high potassium solution was selected

containing sodium, chloride and calcium ions in the amounts found in normal Ringer and 12 mM of potassium ion, compared to 2.5 mM in normal Ringer. Application of this test solution (all solutions had the same osmolarity) to the nerve always resulted in slowing of action potential conduction in the action potentials studied ($n=75$), with 96% ($n=72$) of these axons being perfused to the point of conduction failure. The average survival time of these action potentials in high potassium Ringer solution was 15.5 minutes (\pm SE=3.1) (range >30 seconds - 140 minutes).

Figure 25 shows a typical sequence of record of two action potentials recorded from a peripheral nerve branch during high potassium perfusion. The series of records are shown in chronological order, the faster of the two action potentials in these records will be used to illustrate the results and has been marked with an arrow. This action potential had a stable conduction velocity of 23.5 m/sec during the control period. Following the initiation of high potassium perfusion conduction velocity falls over a 12.5 minute time course before conduction fails, indicated by the all or nothing disappearance of the action potential from the records. Following re-perfusion with normal Ringer conduction velocity recovers to its control value.

Application of the high potassium solution appears to result in a sudden slowing in velocity, followed by a slower drift downwards in velocity. Thus, a jump in latency is evident in the records immediately after the initiation of high potassium perfusion. Despite this, conduction block does not occur for another 12 minutes. This must indicate that slowing in velocity continues after the initial change, but at a much reduced rate.

The time course of the changes in conduction velocity calculated from these data is plotted in Figure 26. It is clear from this plot that the high potassium solution initially produces a rapid, step like, fall in conduction velocity. Following this, however, conduction velocity neither continues falling rapidly until block occurs, nor does it attain a stable plateau level. Rather, a slow drift in velocity is evident, ending in conduction block. Re-perfusion produces a complete restoration of conduction velocity.

A "Step" slowing in conduction velocity is, for the purposes of this study, defined as an initial linear fall. Thus, when the data is plotted as in Figure 26, the change in velocity between 30 minutes and 30.5 minutes clearly constitutes a step

Figure 25

2 unitary action potentials recorded from the isolated frog sciatic nerve. Time is indicated on the left in minutes. Over the period indicated by the bar the nerve is switched from perfusion with normal Ringer to perfusion with 12 mM potassium Ringer. This produces conduction velocity slowing and eventually conduction block. The potential marked with an arrow survives high potassium for 12.5 minutes, after which time it disappears from the record in an all or nothing manner. Re-perfusion with normal Ringer produces complete recovery.

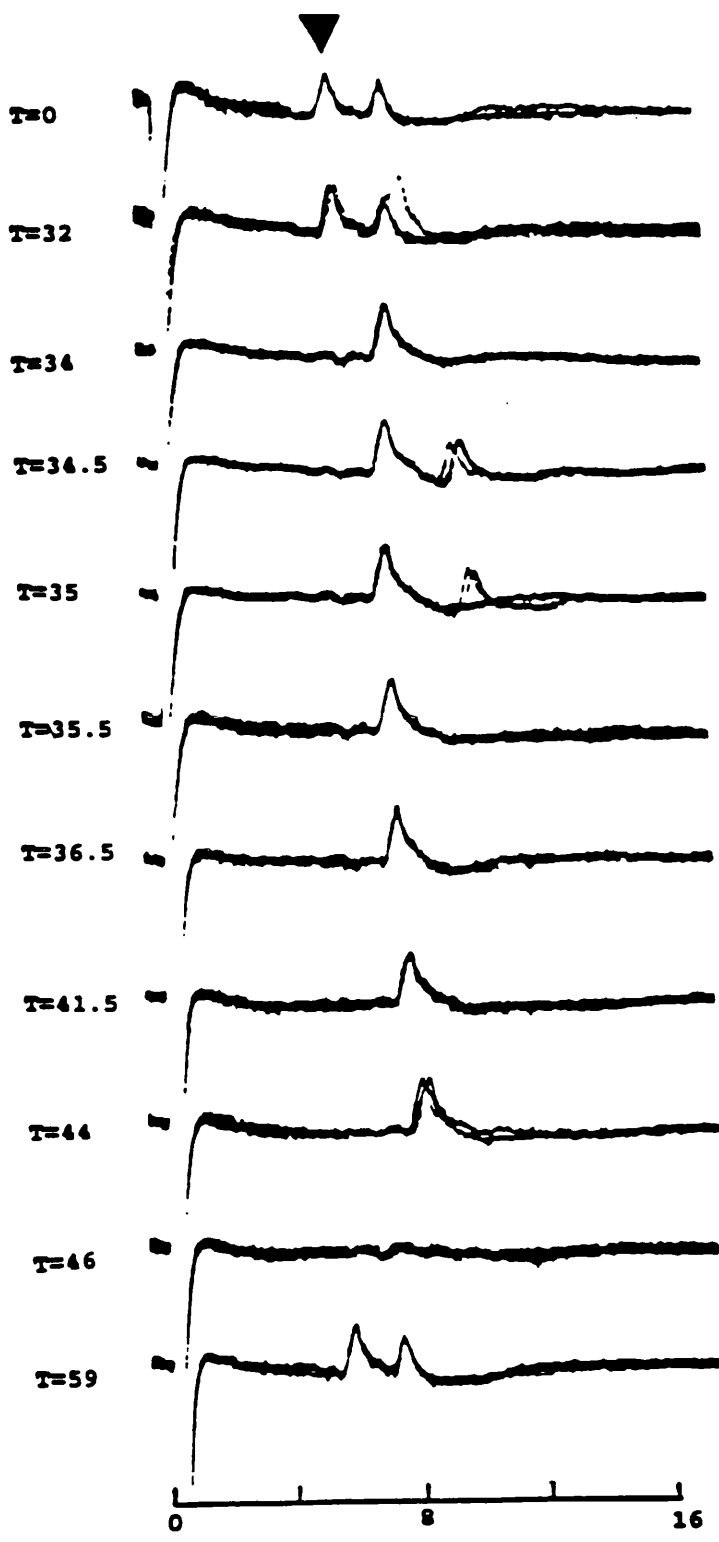

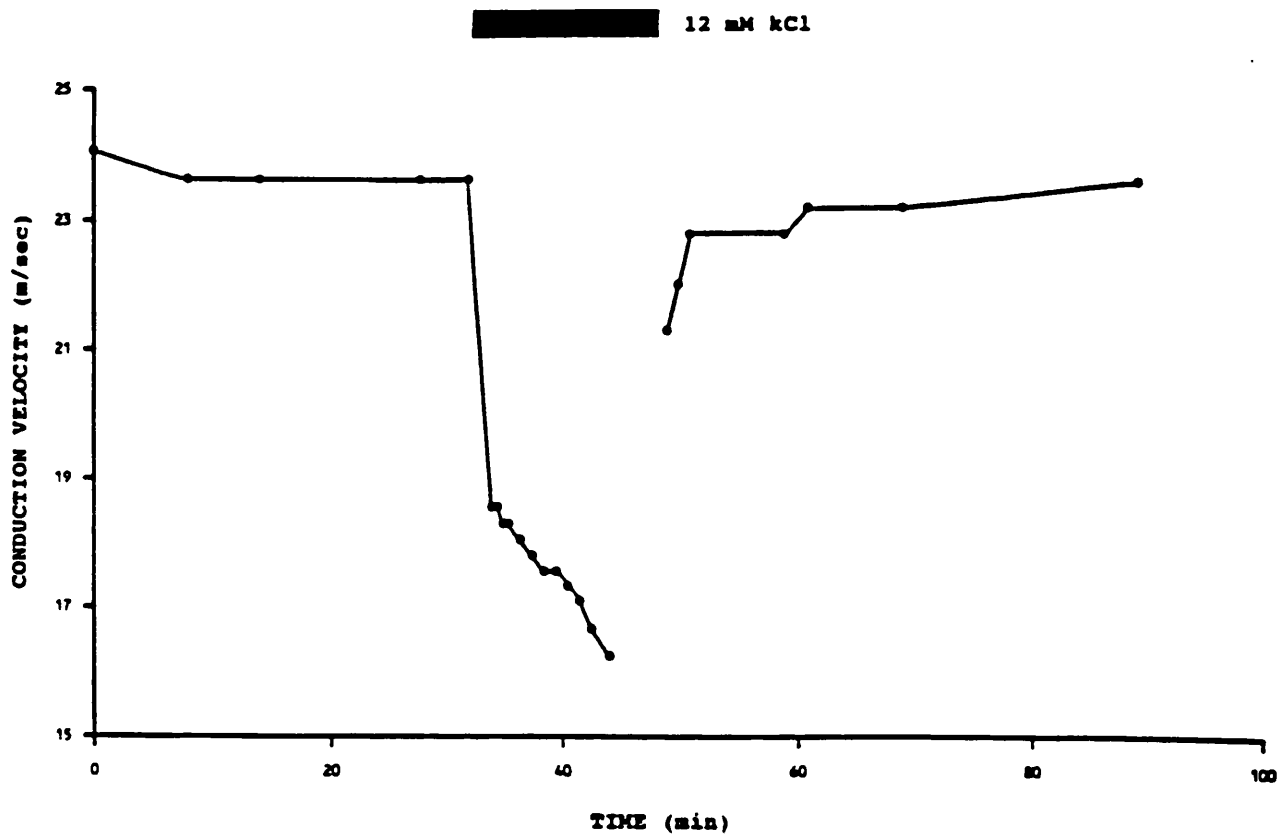

FIGURE 26

Plot of conduction velocity against time for the action potential shown in Figure 27. 12 mM potassium Ringer is applied over the time indicated by the bar. Note that conduction slowing in high potassium involves an initial rapid step-like fall followed by a slower drift, culminating in conduction block.

fall in velocity. A "drift" in velocity is defined if velocity does not continue to fall in a linear manner at the initial rate but deviates towards a slower rate of change for a minimum of three additional data points. It would have been preferable to calculate time constants of rates of change. However, velocity on no occasion achieved a rate of change allowing a meaningful estimate of an asymptote.

Of the 75 action potentials tested with high potassium Ringer 28, (37%) displayed a time course of conduction slowing exhibiting these two components, the fast step drop and the slow drift. However, the majority of action potentials (n=47, 63%), had only a single step fall in velocity, with action potential conduction failing before any later phase of conduction slowing could be seen. On no occasion was a step slowing in conduction velocity followed by a stable level, nor at any time did a drift in velocity approach a plateau level, even in those axons which survived high potassium perfusion for up to 140 minutes.

6. b. 2. *Effect of TEA*

Figure 27; a, b, c, are examples of data collected from the same nerve branch during a protocol designed to investigate the effects of 5 mM TEA perfusion upon potassium induced conduction slowing. Figure 27 a, shows records containing several action potentials; the slowest potential (marked with an arrow) will be used to illustrate these experiments as it is both clear and, having a slow conduction velocity, undergoes large changes in latency.

Figure 27 a shows that 12 mM potassium perfusion produces conduction slowing and block of this action potential and that re-perfusion leads to complete recovery of conduction. These data, and those from Figures 27 b, and 27 c, are plotted in Figure 28 with conduction velocity against time. It can be seen from Figure 28 that the action potential undergoes a rapid step fall in conduction velocity in the high potassium solution, ending in conduction block. There is no second, slow, phase of conduction velocity slowing present in this axon.

Figure 27 b, shows the effects of the same procedure, 12 mM potassium perfusion, upon the same axon, but in this case the nerve has been pre-perfused with 5 mM TEA for 50 minutes. 5 mM TEA is also present in the high potassium solution

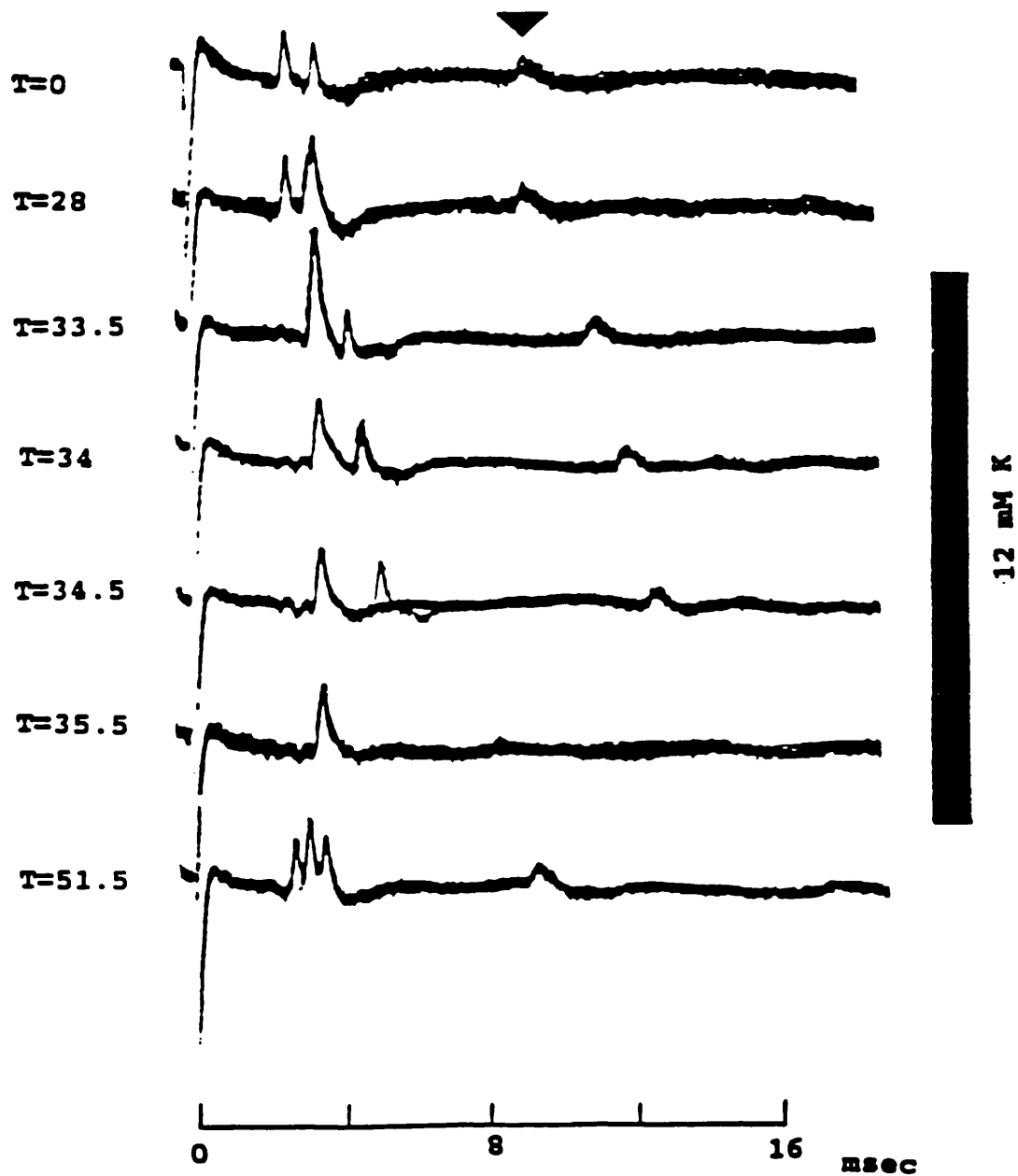

Figure 27 a

A number of action potentials are present in this nerve branch, the slowest of these (marked with an arrow) is used to illustrate the effects of high potassium. The same action potential is shown in Figure 27 b, and 27 c. Time is shown on the left in minutes and high potassium is indicated by the bar.

Figure 27 b

The same action potential shown in Figures 27 a, and 27 c. Over the time shown in these records the nerve is perfused with 5 mM TEA and high potassium perfusion is performed, indicated by the bar.

5mM TEA&12mM K

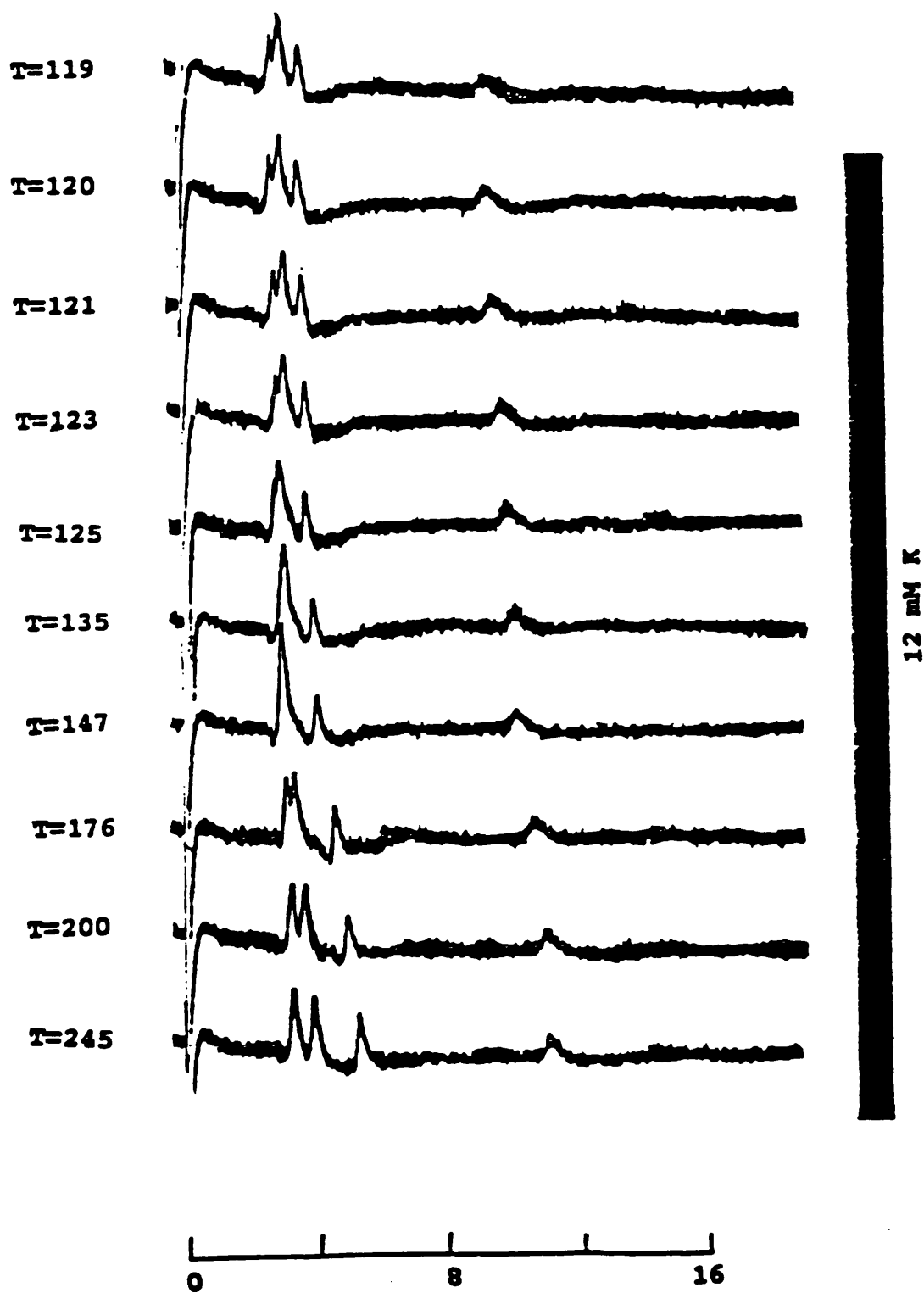

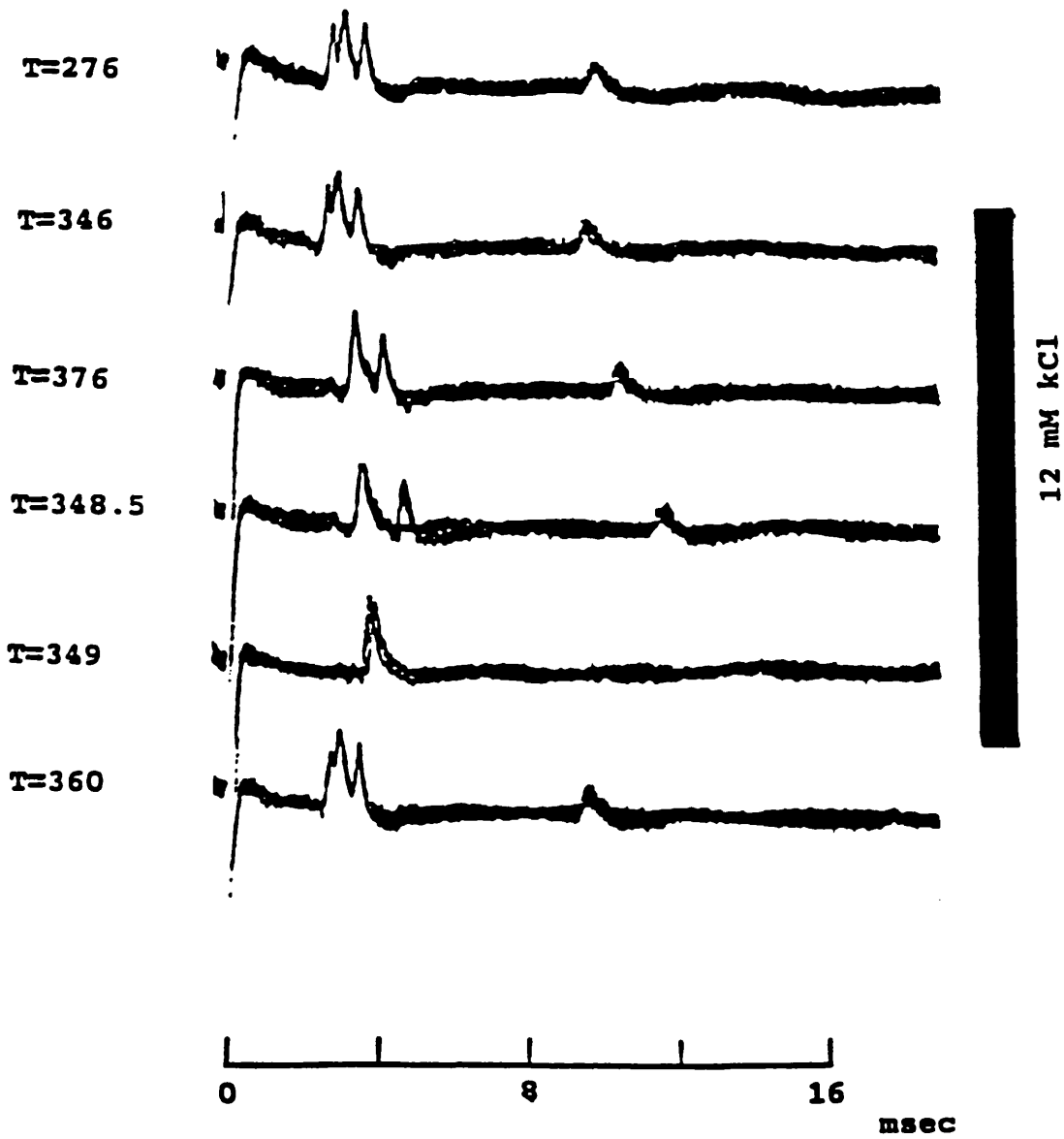

Figure 27 c

As in Figure 27 a, and 27 b, but over this period the nerve is re-perfused with high potassium (indicated by the bar) after TEA has been removed. No slow phase of conduction velocity slowing is present.

and it can be seen that this prolongs the survival time of the action potential in high potassium from 2 minutes to in excess of 126 minutes. In a total of 37 such action potentials subjected to this protocol 5 mM TEA extended survival time by an average of 600%, from 9.4 minutes (\pm SE=2.4) to 56.7 minutes (\pm SE=8), with 7 axons not blocking at all even after between 126-151 minutes of high potassium perfusion. This increase in survival time is statistically meaningful (t-test, $P < 0.001$).

The alteration in the time course of effect of high potassium which results in the extension in survival time by TEA can be observed in Figure 28. High potassium still induces a rapid step fall in velocity in this axon in the presence of TEA, but by a smaller amount than in the absence of the drug. In the presence of TEA the initial fall is not sufficient to produce conduction block. This reduction in the step phase of conduction slowing unmasks a slow drift phase. This change extends the time before action potential conduction fails, in this case to beyond the period of high potassium perfusion.

Such a change in the time course of conduction slowing in high potassium Ringer was found in most of the axons tested in TEA. Thus, the number of action potentials displaying a clear slow drift phase in conduction slowing during high potassium was much increased by TEA perfusion, with 33 out of 37 axons (89%) showing a clear drift in conduction velocity. Only 4 axons (11%) underwent conduction block before a clear slow drift phase could be observed, which compares to 63% in the absence of TEA. As in the absence of TEA conduction velocity did not attain a plateau level in the high potassium solution (in axons which did not fail), even after up to 151 minutes.

Figure 27 c, shows the effects of high potassium upon the same action potential shown in 27 a and b, 60 minutes after 5 mM TEA was washed off the nerve. The high potassium produced block in only 1.5 minutes and it can be seen from Figure 28 that no slow drift phase was present. It was a common observation that the high potassium solution had a more rapid effect after TEA was washed out, with the average survival time being 2.5 minutes (compared to 9.4 minutes prior to TEA treatment).

Figures 30 and 31 are examples of data plots taken from an axon in which TEA effectively abolished the initial step-phase of conduction slowing. Figure 29 shows a typical example of a step and slow drift time course of conduction velocity slowing in

figure: 27

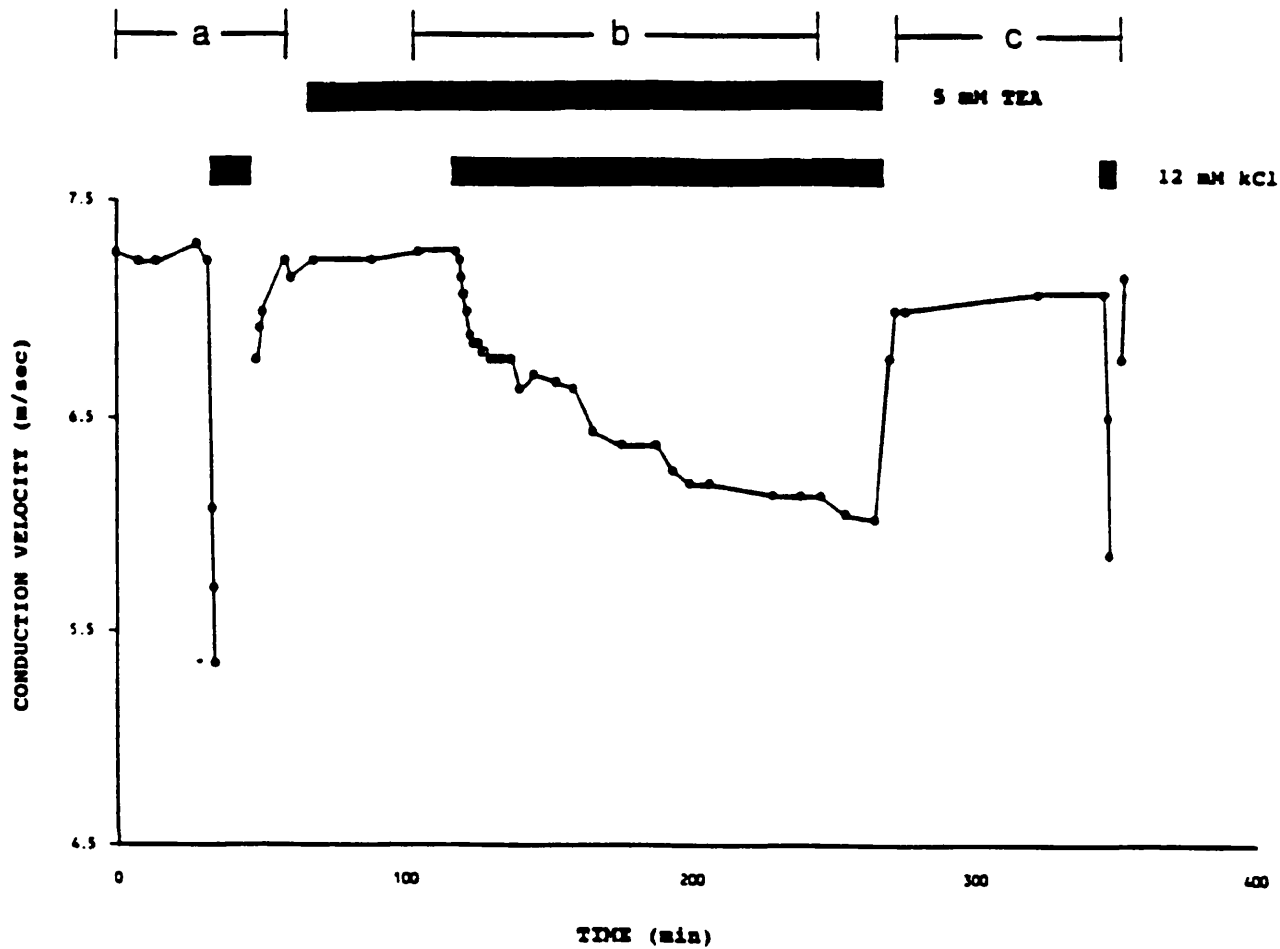

Figure 28

Plot of conduction velocity against time for the action potential shown in Figures 27; a, b, c. Note that TEA perfusion reduced the initial step fall in conduction velocity during high potassium, unmasking a slow drift phase. The periods shown in Figure 27 are indicated at the top and solutions were applied during the bars.

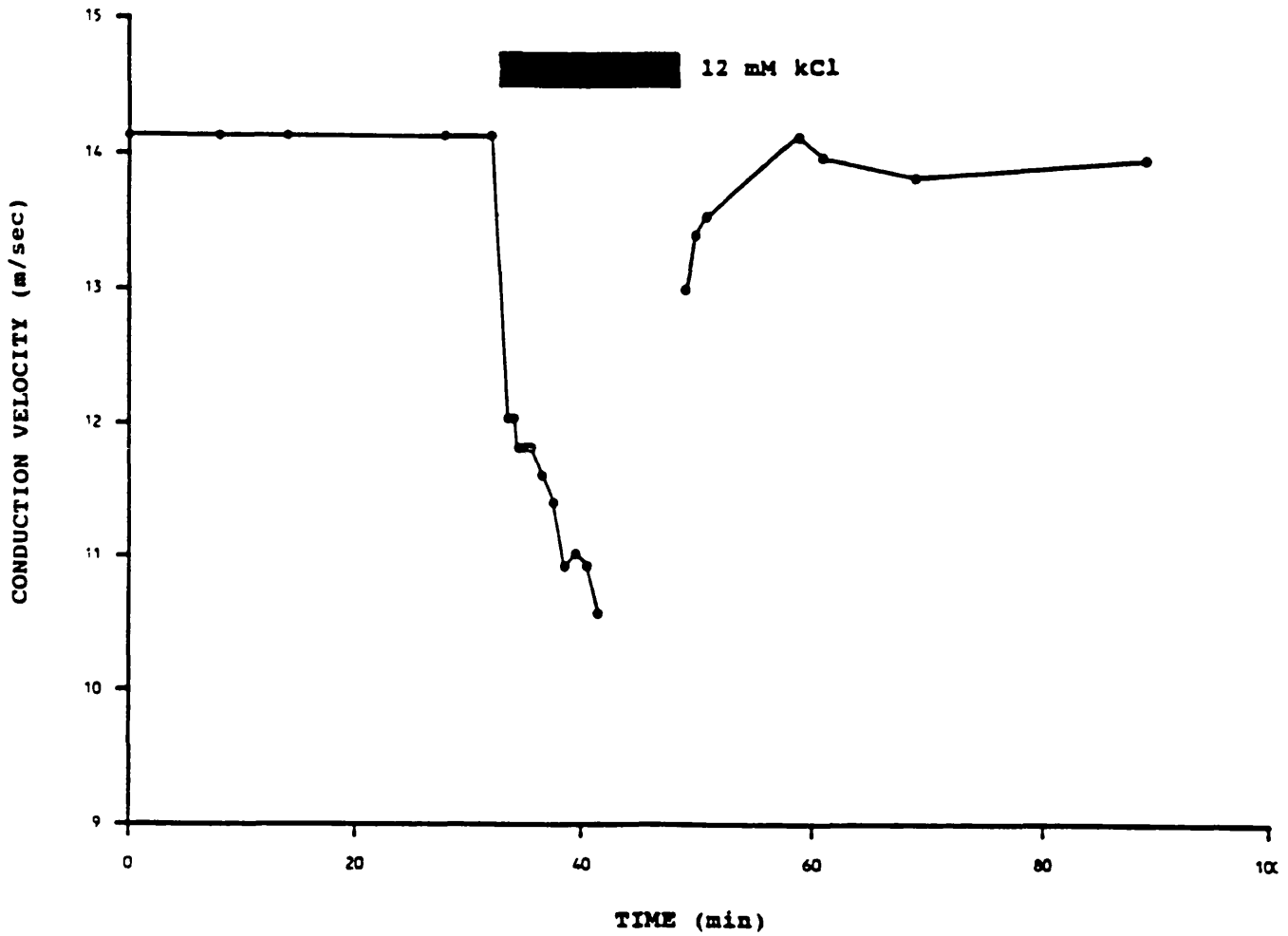

Figure 29

Plot of conduction velocity against time for an axon prior to, during and after 12 mM potassium perfusion (indicated by the bar). A clear step fall and slow drift in velocity can be seen.

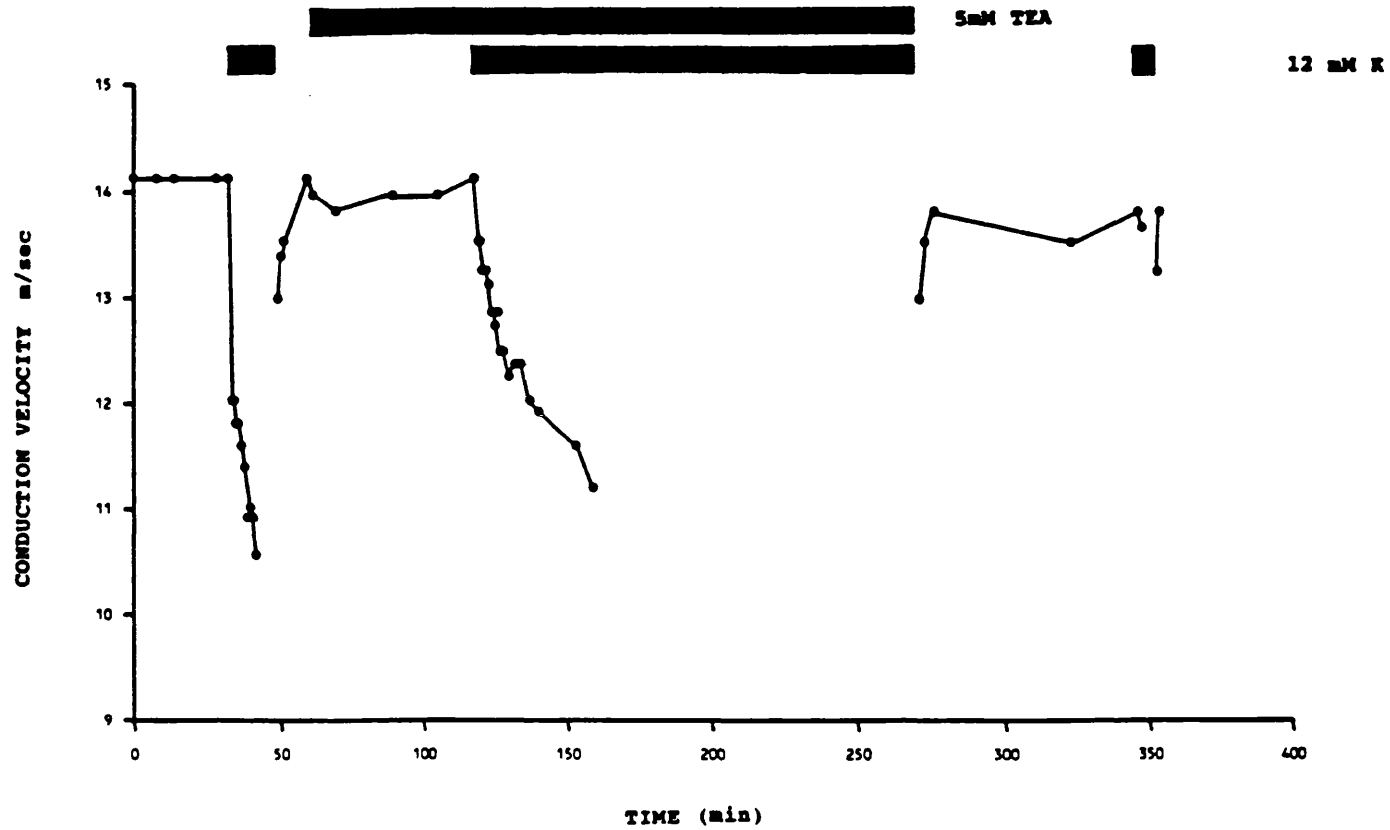

Figure 30

Plot of conduction velocity against time showing the same data as in Figure 31 but with a longer time scale including the effect of TEA upon potassium induced conduction slowing. Solutions are indicated by the bars. In TEA high potassium appears to produce only a small, or no, initial step-fall in velocity but does produce a slow, possibly exponential fall in velocity.

high potassium Ringer. Figure 30 shows the same data over a longer time scale to include the effect of high potassium during TEA perfusion. Survival time is increased by the TEA from 14 minutes to 50 minutes in this axon and only a small, or no, step like fall in velocity is observed.

6. b. 3. *Effects of prolonged TEA perfusion*

As has been shown, pre-perfusion with 5 mM TEA Ringer for 50 minutes was found to affect the time course of conduction slowing produced by high potassium. In a separate series of experiments nerves were perfused for between 250-300 minutes with 5 mM TEA prior to being tested with high potassium. A typical example of the time course of conduction slowing induced by high potassium during this protocol is illustrated in Figure 31.

Of the 25 axons studied in this manner only 1 was found to exhibit a step fall in velocity ending in conduction block, while 24 axons (96%) exhibited drift in conduction velocity. High potassium survival time in these axons was 35.8 minutes (+/- SE=8 minutes).

6. b. 4. *Spontaneous activity following prolonged TEA perfusion*

Spontaneous activity was observed in 4 peripheral branches in nerves perfused for prolonged periods with 5 mM TEA. Figure 32 shows continuous records from two of these nerve branches containing examples of the spontaneous bursts of activity that typified this phenomenon. Bursts of action potentials could also be initiated by a single nerve stimulus (Figure 32, bottom) in at least two nerve branches. Spontaneous activity was not found in all nerve branches in the extended TEA perfusion protocol, in fact only 4 examples, out of 12 branches, displayed clear bursting activity. Under no other circumstance in any of the frog nerve experiments in this thesis was similar spontaneous activity observed.

6. b. 5. *High calcium Ringer and low sodium Ringer perfusion*

It is possible that the slow time course of conduction slowing produced by high potassium in some axons might result from the presence of a remaining diffusion barrier surrounding the axons. Thus, despite efforts to minimise the distance between the

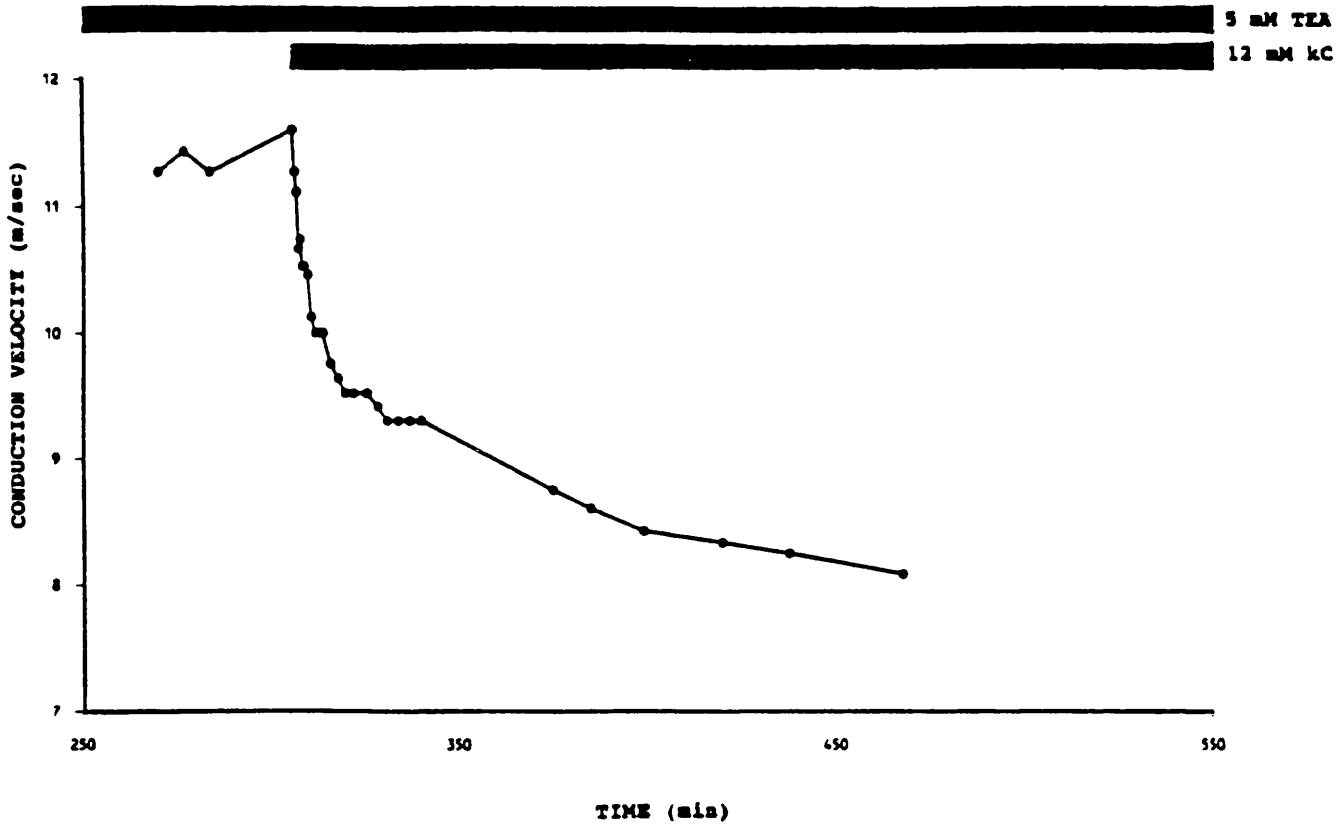

Figure 31

The time course of conduction slowing of an axon recorded from a nerve perfused in 5 mM TEA for 275 minutes. A small step phase is followed by a prolonged drift in velocity.

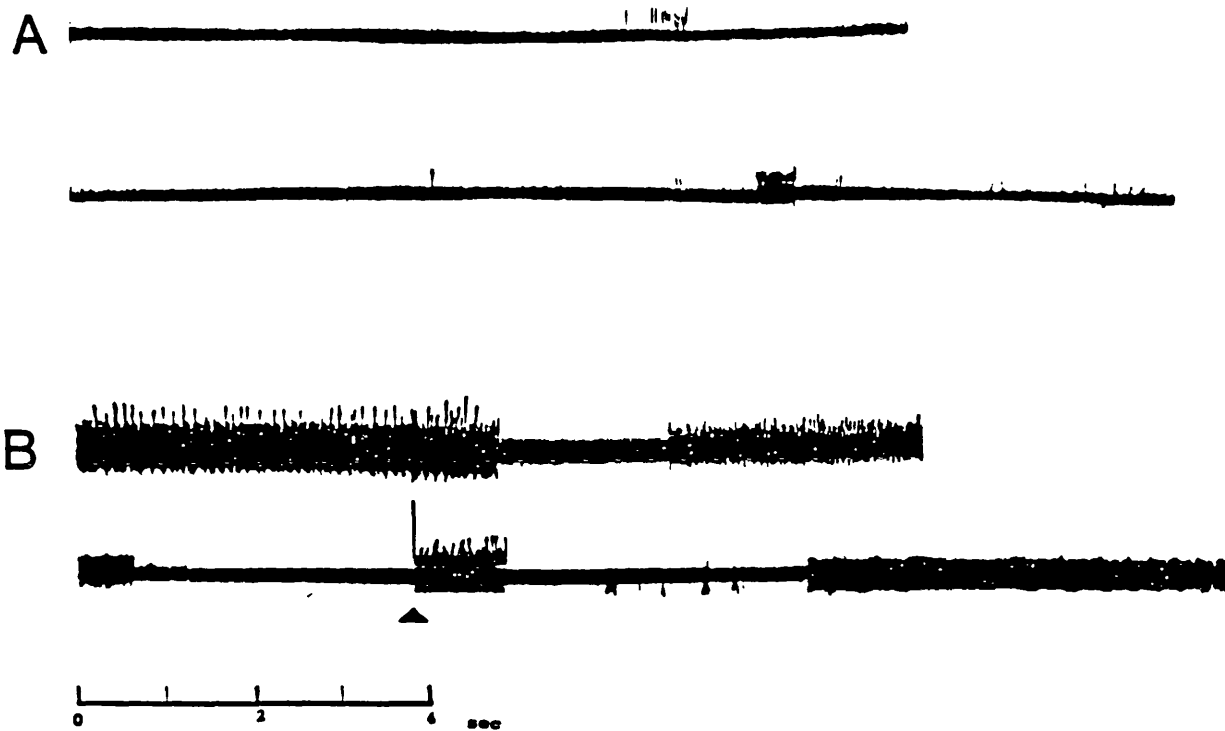

Figure 32

Examples of spontaneous discharges found in nerves that had been soaked in 5mM TEA for between 250-300 minutes. Both the top two traces (A) and the bottom two traces (B) are continuous. In (A) the nerve branch displays a low level of spontaneous activity while in (B) long periods of activity are present. In (B) a voltage stimuli applied to the nerve (at the arrow) elicit a burst of activity. Note the slow time scale.

perfusing medium and the nerve fibres, a diffusion barrier might cause a slow penetration of perfusate into the extracellular space immediately adjacent to the axons.

Evidence that diffusion barriers surrounding the axons are not important is provided by observations made during experiments involving perfusion with low sodium and high calcium solutions. Figure 33 (top), is a plot of conduction velocity against time for an action potential prior to, during and after perfusion with Ringer solution containing only 25% (28 mM) of the normal sodium ion concentration. Reducing the sodium ion concentration to this level produces a rapid stepwise fall in conduction velocity. Likewise, re-perfusion with normal Ringer produces an immediate step recovery in conduction. Similar results were observed in 93 other action potentials tested in this way (most of this data is shown in chapter 7).

In the example shown in Figure 33 there is a very slow drift in velocity with time, independent of perfusing medium. Such a slow change in velocity is probably due to the preparation ageing and was only encountered when nerves had been mounted within the perfusion chamber for long periods, as this nerve had been. The data are included, however, because this axon was earlier tested with high potassium which was found to induce both a step and drift in conduction velocity. Thus, low sodium induces a step in velocity even in axons which have previously show an extended drift in high potassium.

Figure 33 (bottom), is a similar plot but in this case the nerve was switched to perfusion with Ringer solution containing 8 mM of calcium ion (which compares to 2 mM in normal Ringer). This also produced a rapid fall in conduction velocity and re-perfusion with normal Ringer restores conduction close to normal. A similar result was found in 10 other action potentials tested in this manner.

6. b. 6. *Effect of high potassium when $[K]^*[Cl]$ is constant*

When the $[K][Cl]$ product is not constant between the normal and test solutions the depolarisation produced by high extracellular potassium will cause a re-distribution of chloride ions across the axon membrane. If the membrane potential is sensitive to chloride ion concentration this will have additional effects upon nerve conduction. Experiments were performed, therefore, in which chloride ions were substituted with sulphate ions in the 12 mM potassium Ringer solution, to maintain a constant $[K][Cl]$

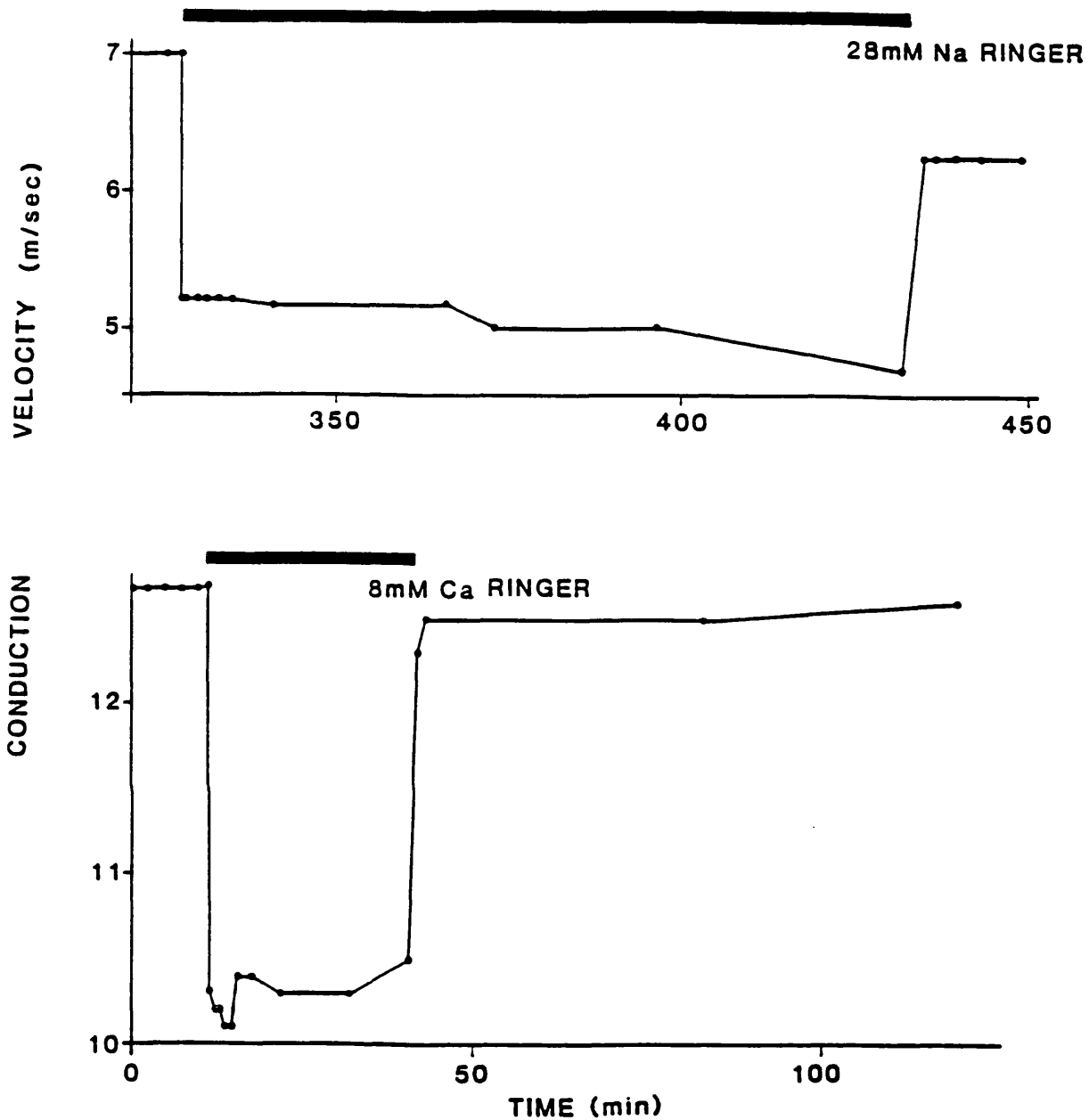

Figure 33

Plots of conduction velocity against time for two action potentials before, during and after perfusion with low sodium (28 mM) Ringer (top) and high calcium (8 mM) Ringer (bottom) solutions, indicated by the bars. In both cases conduction velocity changes in an approximately stepwise fashion.

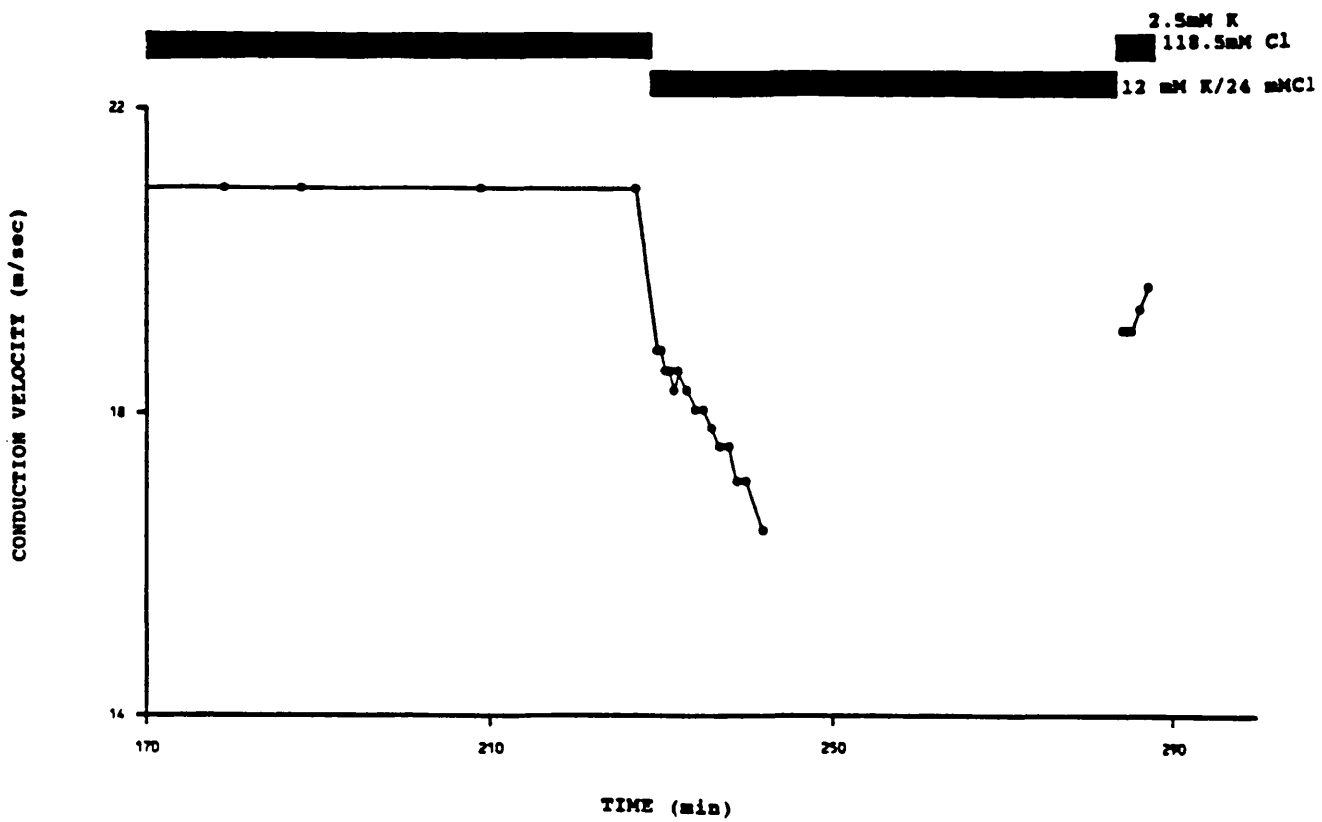

Figure 34

Plot of conduction velocity against time for an action potential perfused with solutions with a constant $[K][Cl]$ product. Solutions are indicated by the bars. Note that the high potassium Ringer produces conducting slowing with an initial step followed by a slow drift.

product between normal and test conditions. Typical results during this protocol are shown in Figure 34.

The data in Figure 34 show how this action potential underwent an initial step fall in conduction velocity in the high potassium, followed by an additional slow drift. Of 13 action potentials recorded during this protocol 57% displayed similar conduction velocity changes and 43% displayed only a step fall, followed by block. On no occasion was a plateau conduction velocity reached in the high potassium solution.

6. b. 7. *Analysis of any differential effects*

One of the initial stimuli for the experiments in this chapter was the proposal that extracellular potassium accumulation might underlie the conduction block encountered during ischaemia. This proposal was based upon a number of theoretical and experimental considerations, which are consistent with the observations found in chapter 4 that ischaemia has a differential effect upon slow conducting myelinated axons. It is therefore of interest to investigate whether high potassium has a differential action upon axons of different diameter.

In Figure 35 the survival time of the 75 action potentials tested with 12 mM potassium Ringer is plotted against initial conduction velocity. A best fit line (method of least squares error) is fitted to this data and it is clear that no statistically meaningful differential effect is found.

Figure 36 is a plot of survival time in 12 mM potassium against initial conduction velocity for the 62 axons pre-perfused with TEA (the plot includes the data for both 50 minute and 250-300 minute TEA perfusion protocols). Once again it is clear from the linear regression analysis that no meaningful differential effect is found.

6. c. DISCUSSION

The results indicate that high extracellular potassium ion concentration, of an order commonly encountered by axons both pathologically and physiologically, has more complex actions upon action potential conduction than previously imagined. Thus, slowing of action potential conduction velocity in high extracellular potassium was often found to occur over a long and complex time course.

A large majority (63%) of axons displayed a monotonic decline in conduction

velocity following high potassium perfusion, with a rapid linear fall in velocity ending in conduction block. A significant minority (37%) of axons, however, survived this initial step fall in velocity. It was found that conduction velocity did not settle to a stable plateau level in these axons. Rather, a slow decline in velocity was noted to follow the initial step fall, with velocity eventually reaching a point which could not maintain conduction in most axons. This diphasic time course of conduction slowing in high potassium probably indicates two sites of action, rather than two separate effects at a single site, for high potassium solutions.

With reference to the observed occurrence of rapid and slow components of conduction slowing, during the various protocols employed, table 2 summarises the results before a detailed discussion is presented.

TABLE 2

| | <i>12 mM K</i> | <i>12 mM K + 12 mM Cl</i> | <i>12mM K + 5 mM TEA</i> | <i>12 mM K + Long TEA</i> |
|----------------------|-----------------------|-------------------------------|------------------------------|-------------------------------|
| <i>STEP ONLY</i> | <i>n=47 (63%)</i> | <i>n=6 (43%)</i> | <i>n=4 (11%)</i> | <i>n=1 (4%)</i> |
| <i>DRIFT</i> | <i>n=28 (37%)</i> | <i>n=8 (57%)</i> | <i>n=31 (88%)</i> | <i>n=24 (96%)</i> |

6. c. 1. *Depolarisation due to high potassium*

According to Boyle and Conway (1941), the membrane potential is a Donnan equilibrium potential dependant upon the trans-membrane concentration gradients of permeant ions (in nerve; sodium, chloride and potassium). Membrane potential, therefore, is dependant upon the reversal potentials for these ion species, thus;

$$(1) \quad E_K = RT/F \log_e [K]_o/[K]_i$$

$$(2) \quad E_{Cl} = RT/F \log_e [Cl]_o/[Cl]_i$$

$$(3) \quad E_{Na} = RT/F \log_e [Na]_o/[Na]_i$$

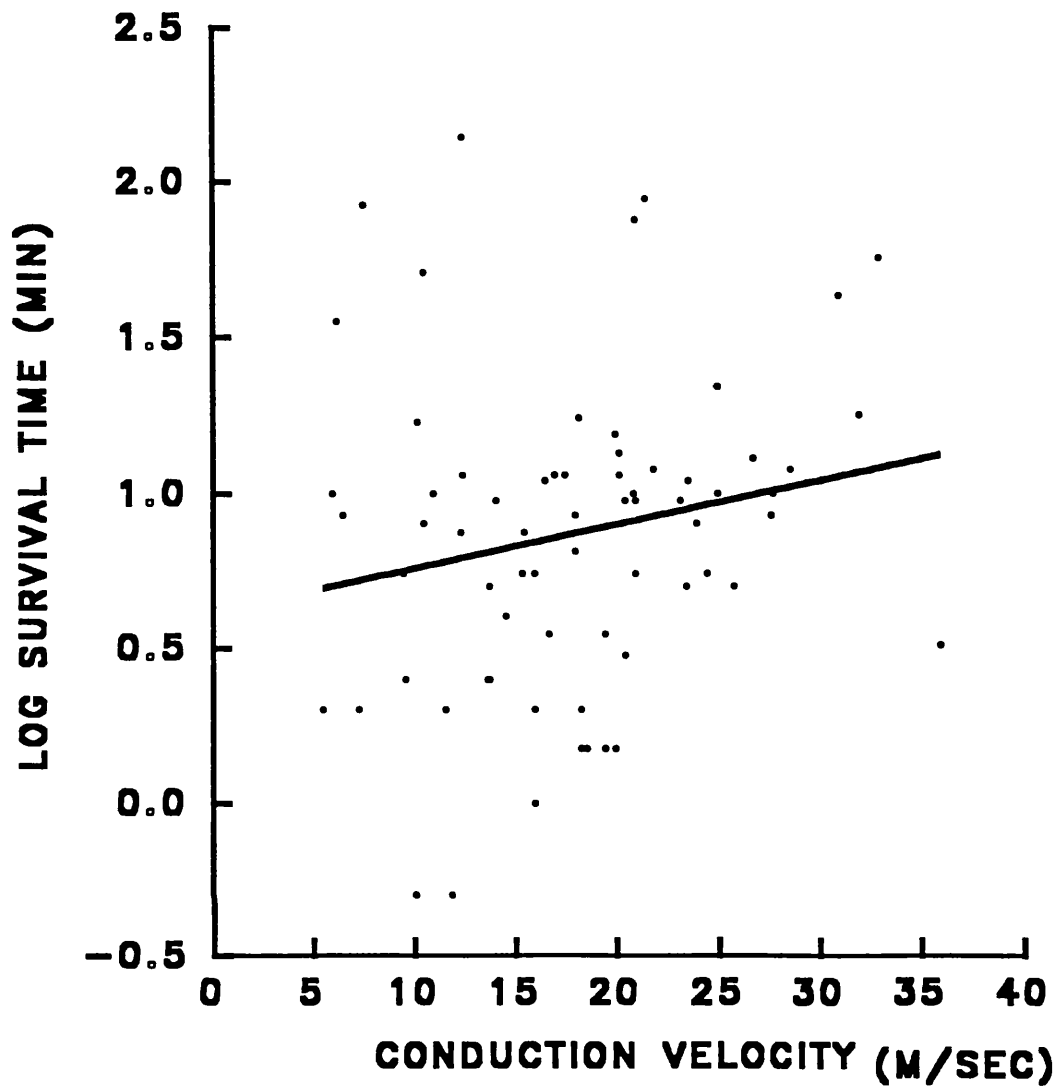

Figure 35

Plot of log survival time in 12 mM potassium Ringer against initial conduction velocity for 75 action potentials. A linear regression line has been fitted to the data and no statistically meaningful correlation is found ($r=0.17$, $P=0.15$).

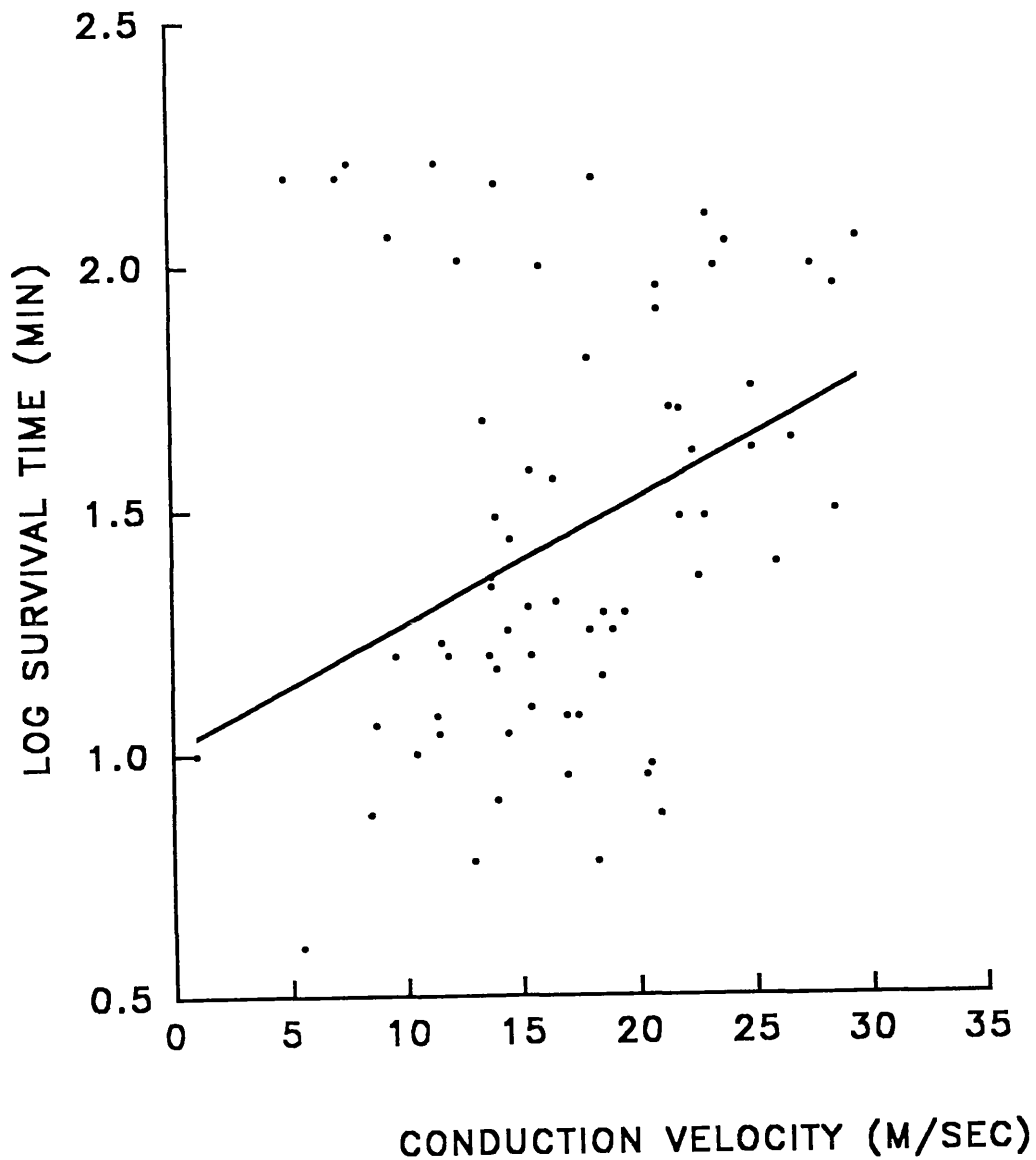

Figure 36

Plot of survival time in 12 mM potassium Ringer against initial conduction velocity for 67 axons pre-perfused with 5 mM TEA. A linear regression line has been fitted to the data and no significant correlation at the $P \leq 0.05$ level is found ($r=0.22$, $P=0.07$).

The contribution made to the membrane potential by the various species of ion will depend upon their relative membrane permeabilities. As chloride ions are passively distributed across the membrane, and as resting sodium permeability is low, resting membrane potential approximates to E_k and;

$$(4) \quad E_k = E_{Cl}$$

In myelinated frog axons the membrane potential is, to a large extent, dependant upon the extracellular potassium ion concentration as predicted by this hypothesis. Thus, Huxley and Stämpfli (1951 b) showed that changing the extracellular potassium concentration from 2.5 mM to 119 mM (isotonic with axoplasm) systematically reduced the membrane potential to zero. In the voltage clamped node of Ranvier, however, slow changes in membrane potential can be observed following perfusion with high potassium solutions (Stämpfli 1959), this being due to the presence of unclamped potassium channels presumably situated away from the node (Stämpfli 1983). Such changes will not occur in the unclamped axon.

The experimental findings of Huxley and Stämpfli (1951 b) are not completely consistent with the potassium reversal potential hypothesis of membrane potential, particularly over small changes in extracellular potassium concentration from the normal. Thus, stepping from 2.5 to 12 mM extracellular potassium will depolarise frog myelinated axons by approximately 18 mV (from Huxley and Stämpfli, 1951 b: Figure 3), which deviates approximately -11 mV from the depolarisation predicted from equation 1.

Similar negative deviations from the potassium reversal potential hypothesis of resting membrane potential have been found in frog muscle (Hodgkin and Horowicz, 1959; Conway, 1957). This deviation is usually ascribed to the contribution made to the membrane potential by ionic conductances other than potassium. Thus, it has been suggested that the frog axon membrane has a large leak conductance and a small potassium conductance at resting potential (Stämpfli and Hille, 1976). More recently, however, Baker *et al.* (1987) have clarified a number of inconsistencies with regard to the importance of leak conductance in myelinated axons. These authors advance the alternative model that the resting potential is mainly set by the internode, and is

conducted to the node via the electrotonic pathway described by Barrett and Barrett (1982). This model adequately describes all the phenomena associated with the ohmic leak behaviour of the node while requires no ohmic leak channels.

6. c. 2. *Slow changes in conduction velocity can not be accounted for by any known effect at the nodal axolemma*

Depolarisation of the axolemma, resulting from the change in potassium ion concentration, will have clear consequences for conduction velocity. Thus, the inward sodium current which underlies the rising phase of the action potential will be affected in two ways. 1) The driving force for sodium ion entry will be reduced and 2) the level of sodium channel inactivation will be increased (Dodge and Frankenhaeuser, 1958; Frankenhaeuser, 1959; Frankenhaeuser, 1963 c; Frankenhaeuser and Huxley, 1964).

Sodium channel inactivation will be the more important of these two factors. Thus, the data of Huxley and Stämpfli (1951 b), indicate an 18 mV depolarisation in the frog myelinated axon when potassium concentration is increased from 2.5 to 12 mM. As a result the proportion of sodium channels available to carry the inward sodium current will fall from approximately 80% to only 35% (Dodge and Frankenhaeuser, 1958). In addition to this inactivation of the sodium conductance the driving force (electromotive force (emf)) for sodium ion entry will fall from 125 mV to 107 mV. These changes in sodium channel inactivation and emf for sodium ion entry will be virtually simultaneous with membrane depolarisation (Dodge and Frankenhaeuser, 1958; Frankenhaeuser, 1959; Frankenhaeuser, 1963 c).

In addition to these fast changes in membrane conductance several forms of slow conductance changes will occur. Thus, "ultra-slow sodium inactivation", and a similar ultra-slow inactivation of the potassium conductance, will follow depolarisation (Fox, 1976). These ultra-slow changes will be complete within 4 minutes, however, and can not account for the very slow changes in conduction velocity observed in the results. In addition, the potassium dependant slow sodium inactivation may co-exist with these other slow events, but will be complete within a second (Adelman and Palti, 1969; Peganov, Khodorov, Shishkova, 1973). The time course of these events will therefore be far faster than the slow changes in conduction velocity observed here.

Thus, slow changes in membrane conductances following a rapid membrane depolarisation are unlikely to underlie the slow changes in conduction velocity found in the results. Is a slow drift in membrane potential an alternative explanation? As has been mentioned, changes in extracellular potassium have a great influence upon membrane potential, but membrane potential can also be influenced by the transmembrane concentrations of other ion species. In addition, as chloride ions are passively distributed across the membrane, an equilibrium must be re-established to satisfy equation (4) following high potassium perfusion. This will involve a redistribution of chloride ions which can in itself produce a slow change in membrane potential in some types of cell.

In frog muscle fibres a rapid step depolarisation of 35 mV is followed by a further slow depolarisation of 8 mV over a 40 minute period, subsequent to 10 mM potassium perfusion (Hodgkin and Horowicz, 1959: Figure 7). This is a consequence of chloride ion re-distribution. The similarity in time course of this change in membrane depolarisation to the slow changes in conduction velocity noted in the current experiments may indicate a similar event in the frog axolemma. However, as it has been shown that the frog nodal membrane potential is not significantly influenced by changes in chloride ion concentration (Frankenhaeuser, 1962; Århem, Frankenhaeuser and Moore, 1973), this can not be the case. Indeed, neuronal membranes generally have a much lower chloride conductance compared to muscle membranes (Hille, 1992). Thus, Huxley and Stämpfli (1951 b) found no slow change in resting membrane potential in frog myelinated axons in high potassium solutions. In fact, rapid step changes in potential were observed which contained no consistent slow drift, particularly at potassium concentrations below 40 mM.

The slow changes in membrane potential observed by Hodgkin and Horowicz (1959) in frog muscle did not occur if $[K][Cl]$ product was maintained as a constant. In the current experiments similar changes in conduction velocity were found following high potassium perfusion whether $[K][Cl]$ product was constant or not. Thus, on both experimental and theoretical grounds, slow changes in membrane potential arising at the node of Ranvier can not account for the slow changes in conduction velocity observed in the results.

It will be argued later in the discussion that the slow changes in conduction

velocity are in fact due to a slow depolarisation of the internodal axolemma, affecting the nodal membrane potential by electrotonic spread of charge. This, however, does not contradict Huxley and Stämpfli's (1951 b) findings. Thus, as has been pointed out by Barrett and Barrett (1982), recording methods which electrically isolate the internode, such as those used by Huxley and Stämpfli (1951 b), will greatly inhibit current flow from internode to node.

6. c. 3. *Possible double site of action of high potassium solutions*

As has been mentioned, the time course of conduction slowing during high potassium perfusion was found to contain two components, provided action potential conduction did not fail before the second phase of conduction slowing could be observed. One possibility is that this is the result of there being two sites of action of the high potassium solution, which are not equally accessible to potassium ions. Morphological considerations lend support to this possibility, suggesting that these two sites may be the node of Ranvier, which should be highly accessible to potassium ions, and the periaxonal space, which should be less accessible.

6. c. 4. *Initial step fall in velocity*

Studies of serial reconstructions from electron micrographs have revealed details of the fine structure of the axon. This kind of study has generally concentrated upon the node of Ranvier and the para-nodal regions. Nodes of Ranvier have been shown to have a relatively small opening to the extracellular matrix, being less than 1μ wide in the cat (Rydmark and Berthold, 1983). Despite this, it appears that potassium lost from the axon during activity is not retained within the perinodal space. Thus, it has been calculated that the perinodal space is so small that potassium lost from the axon during a single action potential would cause conduction block, if it did not quickly escape into the extracellular matrix (Rydmark and Berthold, 1983).

The reverse must also be true, that potassium ions will rapidly enter the node from the extracellular medium during high potassium perfusion, as has in fact been shown by the rapid fall in membrane potential observed following high potassium perfusion in frog myelinated axons (Huxley and Stämpfli, 1951 b; Ulbricht, 1981, 1983). The more recent work (Ulbricht, 1981, 1983) monitored the time course of

potential changes following high potassium perfusion with great precision and concluded that potassium reaches equilibrium at the nodal membrane surface with a half time of only 18 msec. Thus, it therefore seems reasonable to attribute the initial step fall in conduction velocity in the high potassium solution to such an event. In 63 % of the axons studied this phenomenon was sufficient to produce conduction block in 12 mM potassium.

6. c. 5. *Slow drift in velocity - a second site of action for potassium*

As there is no evidence that potassium has any slow effect upon membrane conductances (ie. over many minutes), and as a slow change in potential arising at the node of Ranvier has been ruled out, the slow secondary change in velocity must result from an action at some other site in the axon.

Although other possible second sites of action for high potassium solutions exist (such as the Schwann cell) the most probable second site is the periaxonal space. This compartment exists under the myelin sheath, being a gap some 2-20 nm wide in the cat axon (Berthold, 1978). Large molecules such as horseradish peroxidase can penetrate into this compartment (although slowly) (Krishnan and Singer, 1973), as can small charged molecules such as TEA, which takes longer than 10-20 minutes to equilibrate into the periaxonal space of lizard axons (Barrett *et al.* 1988).

In the frog myelinated axon, Chui (1982) has shown that changes in leak conductance occur with a two component time course following a rapid increase in extracellular potassium. Thus, leak conductance changes took some 20-30 minutes to be complete. Chui (1982) and Barrett *et al.* (1988) have argued that this is the result of slow diffusion of potassium ions into the periaxonal space. All of this evidence suggests that the periaxonal space of the frog axon is accessible to high potassium solutions.

That the periaxonal space might be an important element in action potential conduction was first indicated by the work of Barrett and Barrett (1982). These workers suggested that the electrical resistance via the route: node of Ranvier --> paranodal seal --> periaxonal space, is low enough for considerable amounts of current to flow along it during the action potential. This hypothesis has been supported up by a substantial body of evidence (Blight, 1985; Blight and Someya, 1985; Baker *et al.*

1987; Barrett *et al.* 1988; Bostock *et al.* 1991 a, b; David *et al.* 1992), which confirms Barrett and Barrett's (1982) original postulation that this pathway is the functional correlate of the depolarising after-potential.

The nodal and internodal axolemma are continuous and are, therefore, electrotonically coupled. The degree of coupling will depend upon the resistance of the periaxonal space-perinodal space pathway, compared to the resistance of the periaxonal space-extracellular space pathway (ie. transversely across the myelin sheath) (Barrett and Barrett, 1982; Chui and Ritchie, 1984). Values of 9 M Ω cm and 29 M Ω cm respectively have been estimated for these current pathways (Barrett and Barrett, 1982). Potential changes across the internodal axolemma can therefore be expected to have distinct consequences for the nodal membrane potential (Chui and Ritchie, 1984).

The presence of a potassium conductance in the internodal axolemma in the frog (Chui and Ritchie, 1982; Grissmer, 1986), will make the internodal membrane potential sensitive to the potassium ion concentration in the periaxonal space. It can be concluded, therefore, that potassium diffusion into the periaxonal compartment in the frog will generate a depolarisation of the nodal membrane additional to that resulting from the initial influx of potassium into the node of Ranvier.

6. c. 6. *Slow time course of action at second site, compared to recovery.*

If the slow component of conduction slowing in high potassium is due to potassium diffusion into the periaxonal space, it is surprising that the rate at which this occurs is so slow. Thus, on no occasion did conduction velocity reach a stable level in high potassium even after 150 minutes of perfusion. This suggests that potassium concentration within the periaxonal space does not equilibrate with the extracellular potassium within this period.

It was also noticeable in the current experiments that recovery of conduction following re-perfusion with normal Ringer was rapid, containing no consistent slow component. This could be most clearly seen in the TEA perfusion experiments. In Figure 28, for example, a long slow drift in velocity recovers virtually back to normal within a minute of re-perfusion. Both of these observations, the peculiarly slow rate of the second phase of conduction slowing, and the rapid recovery, would be explained if potassium ion concentration within the periaxonal compartment is under some form

of effective regulation.

That this may be so is indicated by the work of David *et al.* (1992), who have shown that a potassium concentration of between 20-100 mM is cleared from the periaxonal space of the lizard axon in under 30 seconds. How this is achieved is unknown, but is presumably dependant upon activity of sodium potassium ATPase. Bostock *et al.* (1991 a, b) have found evidence that a high potassium concentration within the periaxonal space generates increased levels of sodium pumping in the internodal axolemma. Thus, spontaneous discharge of post-ischaemic axons apparently requires an increased electrogenic sodium pump current in the internode, a probable consequence of ischaemic potassium accumulation.

If potassium ions are being continually removed from the periaxonal space then the periaxonal potassium concentration will rise more slowly than if this were not the case. That conduction velocity slowing apparently resulting from potassium influx into the periaxonal space is so slow, indicates that the rate of removal of potassium ions is high, compared to the rate of potassium diffusion into the space. It can also be predicted that the rise in periaxonal potassium, following raised extracellular potassium, will equilibrate to a lower level than if no such regulating mechanism existed.

Chui (1982) reported changes in leak conductance in the voltage clamped frog axon occurring over a 20-30 minute time course following high potassium perfusion. This suggests a significantly faster rate of increase in periaxonal potassium than in the current findings. Two possible reasons for the discrepancy exist. 1) Disturbance of the paranodal architecture during micro-dissection leaves the periaxonal space more open to the perinodal space than in non-micro-dissected axons. 2) The low temperatures employed during single node voltage clamp experiments (3°C, Dodge and Frankenhaeuser, 1958) inhibit the active clearance of potassium from the periaxonal space.

6. c. 7. *The effect of TEA*

Conduction velocity slowing in high potassium can be explained in terms of membrane depolarisation following the change in E_K . However, in frog myelinated axons, 12 mM potassium is less effective, by some 38%, at generating depolarisation than equation (1) predicts (Huxley and Stämpfli, 1951 b: figure 3). This is presumably

due to the presence of a large contribution to the total membrane conductance from ionic conductances other than potassium at this membrane potential (Stämpfli and Hille, 1976).

In all probability the protective effect of TEA against 12 mM potassium (extending survival time by 360%) can be explained in terms of a reduced dependence of membrane potential upon E_K . As TEA blocks potassium channels (Hille, 1967), and will reduce the proportion of membrane conductance attributed to potassium ions, such a result is to be expected. Thus, 5 mM TEA will block the steady state frog nodal membrane potassium conductance by 90% (Hille, 1967), while having no significant effect upon sodium conductance.

The results indicate, however, that it is the initial step fall in velocity which is primarily effected by 5 mM TEA. Thus, the initial step was on some occasions effectively abolished by the TEA, leaving distinct drift phases of slowing. This ablation of the early phase of slowing by TEA results in an decrease in the number of axons which fail during an initial step from 63% to 12% following TEA treatment, while on no occasion was TEA observed to inhibit a slow drift phase of conduction slowing.

Grissmer (1986) has demonstrated the presence of a TEA insensitive potassium current in the internode of frog myelinated axon. Thus, 11% of the potassium current across the internodal axolemma could not be blocked even by 110 mM TEA. That there is a significant TEA insensitive potassium conductance in the internodal axolemma, and that TEA appears to have its most significant effects upon the initial step fall in velocity, is thus consistent with the two site hypothesis for the action of high potassium solutions presented above.

The block of nodal potassium channels following TEA perfusion will result in an increased nodal membrane resistance (as total nodal membrane conductance will be reduced). This will potentiate the effect any depolarisation spreading from the internode has upon the node (Chui and Ritchie, 1984). This may explain why the drifts in conduction velocity were so marked following TEA perfusion, if the slow drift results from an internodal depolarisation.

6. c. 8. *Spontaneous discharge in TEA*

No consistent increase in conduction velocity accompanied the application of 5

mM TEA (eg. Figures 29 b, 30, 32), indicating that no great change in membrane potential is produced by this drug. This is consistent with previous observations that TEA produces a depolarisation of only a few millivolts in frog axons (Stämpfli and Hille, 1976). Membrane depolarisation resulting from TEA perfusion does not, therefore, underlie the bursts of action potentials observed following the prolonged application of TEA in some nerves.

Similar spontaneous activity to that found in the current results can be induced in frog axons by TEA if axon excitability is first raised by reducing the extracellular calcium ion concentration (Bergman, Nonner and Stämpfli, 1968). In the rat, block of potassium channels with TEA has been shown to reduce accommodation and potentiate the transmission of trains of action potentials (Baker *et al.* 1987; Kocsis, Eng, Gordon and Waxman, 1987). Possibly, in axons perfused for long periods with TEA, a general depolarisation due to the preparation ageing is imposed upon the block of a similar TEA sensitive conductance. Such a combination may explain the bursts of action potential observed under these conditions.

6. c. 9. *Effects of high calcium and low sodium solutions*

Both low sodium and high calcium solutions were found to induce a stepwise fall in conduction velocity in all axons tested. Hydrated calcium ions are considerably larger than either hydrated sodium or hydrated potassium ions (Hille, 1992), and are known for their ability to bind to various proteins. Both of these characteristics suggest that if a diffusion barrier is responsible for the slow effect of high potassium ion solutions then calcium ions should also have a slow action upon nerve fibres. That both high calcium and low sodium produce rapid effects must indicate, therefore, that diffusion barriers do not significantly restrict ionic diffusion onto axons in this preparation.

High potassium, low sodium and high calcium perfusion will induce conduction slowing via completely different mechanisms. Lowering the extracellular sodium will reduce the electromotive force for sodium ion entry ($E_m - E_{Na}$) as a result of the reduced E_{Na} predicted by equation (3), resulting in a smaller inward current during the rising phase of the action potential. Raising the extracellular calcium concentration will affect a shift in the voltage dependence of the sodium conductance in the hyperpolarising direction (Frankenhaeuser and Hodgkin, 1957), which can be significant enough to

produce conduction block in the frog, if high calcium concentrations are used (Fern and Harrison, 1988).

Thus, neither low sodium or high calcium have their effects upon nerve conduction via a membrane depolarisation. The results indicate that, although all three solutions presumably diffuse into the periaxonal space, only high potassium, which does have its effects via membrane depolarisation, elicits a slow drift in conduction velocity following the initial step fall.

6. c. 10. *Lack of differential effects*

Unlike the results in Section I of this thesis the primary aim of these experiments was to investigate how conduction velocity changed under the test condition, rather than to investigate a relationship between initial conduction velocity and survival time. To this end far fewer action potentials were recorded from each nerve branch, minimising interference in the action potential monitoring process. One consequence of this is that the analysis of differential effects attempted in the results contained only a limited number of data.

In chapter 7, data is presented which suggests that the slowest conducting myelinated axons have a low safety factor for nerve conduction, which corroborates the theoretical predictions of Chiu and Ritchie (1984). If this is true, it might be expected that high potassium should have a similar effect, especially as potassium accumulation within the periaxonal space should have an additional differential action upon small axons (see chapter 4). However, the current data is not as suitable for this kind of analysis as that used in chapter 7, and meaningful conclusions regarding differential effects of high potassium solutions can not be drawn.

6. c. 11. *Are slow changes in conduction velocity important during pathological and physiological high potassium?*

The blocking concentration of extracellular potassium has previously been reported to be in the range 10-20 mM (Huxley and Stämpfli, 1951 b; Heinemann and Lux, 1977; Grossman and Gutnick, 1981; Kocsis, Malenka and Waxman, 1983;

Bostock *et al.* 1991 b). The results of the current chapter indicate that the blocking concentration of potassium will in fact be time dependant. Thus, although only 37 % of axons had failed after a 5 minute exposure to 12 mM potassium, 97% of axons did eventually fail after up to 140 minutes. Even in axons which survived 12 mM potassium for long periods no stabilisation of conduction velocity was observed. Although no estimate of the steady state blocking concentration of potassium can be made from the current findings the upper limit for frog axons must be in the region of 12 mM.

Extracellular potassium concentration within the central nervous system often reaches a level similar to that employed in the current chapter. During periods of intense activity potassium can reach as high as 6-9 mM in the cat sensory motor cortex (Heinemann and Lux, 1975), the cat thalamus (Gutnick, Heinemann and Lux, 1979), the cat spinal cord (Krnjević and Morris, 1973; Kříž, Syková and Vyklický, 1975), the cat cerebral cortex (Heinemann and Lux, 1977), and the frog spinal cord (Syková, Shirayev, Kříž and Vyklický, 1976; Syková and Orklan, 1980; Grafe, Reddy, Emmert and Bruggencate, 1983). Stronger electrical or chemical stimulation can raise the potassium concentration to 9-12 mM in these tissues, but not beyond that point (Hansen, 1985; Dietzel and Heinemann, 1986).

It appears, therefore, that extracellular potassium concentration can reach values which are likely to block action potential conduction in axons running within regions of high electrical activity. The literature indicates, however, that potassium very rarely exceeds 9 mM, a level which the current findings suggest will only block action potential conduction if it is maintained for a significant length of time. Thus, two conditions must be met before CNS axons are likely to fail due to physiologically high potassium. Potassium must reach the extreme of its physiological range and must stay at that level for a long period of time.

Under pathological conditions, such as during spreading depression or anoxia, extracellular potassium often exceeded 12 mM, rising to levels in excess of 30-40 mM (Vyskočil, Kříž and Bureš, 1972; Kraig and Nicholson, 1978; Reddy and Bureš, 1980, Walz and Hertz, 1983; Hansen, 1985). It is clear from the current findings that such levels of potassium will rapidly block action potentials in axons, an event that will therefore be associated with the general loss of excitability in these conditions. That the current experiments have shown that recovery from high potassium block is rapid,

indicates that slow recovery from axon conduction block resulting from the high potassium will not complicate recovery of function in these pathological situations.

CHAPTER 7

THE EFFECTS OF LOW SODIUM PERFUSION UPON NERVE
CONDUCTION

7. a. INTRODUCTION

An important question in the physiology of nerve fibres relates to the possible existence of a relationship between conduction velocity and safety factor. Safety factor can be defined as the current generated during an action potential divided by the current threshold for action potential activation (Rushton, 1937; Tasaki, 1959). In functional terms it relates to the tendency of axons to conduction failure. Thus, an axon with a low safety factor will easily block under conditions which inhibit action potential conduction.

In this chapter action potentials have been recorded from myelinated frog axons in which perfusion with normal Ringer was switched to perfusion with low sodium Ringer. Reducing the extracellular sodium concentration in this manner will result in a reduction in the emf driving sodium ion entry during the rising phase of the action potential. Action potential conduction is thus inhibited under this condition.

The sodium ion concentration used (28 mM) was selected such that action potential conduction was inhibited to the point of failure in only a minority of axons. These axons must be those most predisposed to conduction failure, ie. those axons with the lowest safety factor. The majority of axons survived the low sodium perfusion but experienced slowing of action potential conduction. By monitoring the degree of conduction slowing that occurs in these action potentials, axons with a low safety factor, but which survive low sodium perfusion, can also be identified.

7. b. RESULTS

Figure 37 shows a unitary action potential recorded from the isolated frog sciatic nerve before, during and after perfusion with Ringer solution containing only 25% (28 mM) of the normal sodium ion concentration. The action potential has a stable conduction velocity prior to low sodium perfusion but rapidly falls to a lower level after the solutions are changed. Recovery of conduction velocity back to control levels follows re-perfusion with normal Ringer.

The conduction velocity of the action potential shown in Figure 37 is plotted against time in Figure 38. It can be seen from this that the low sodium solution

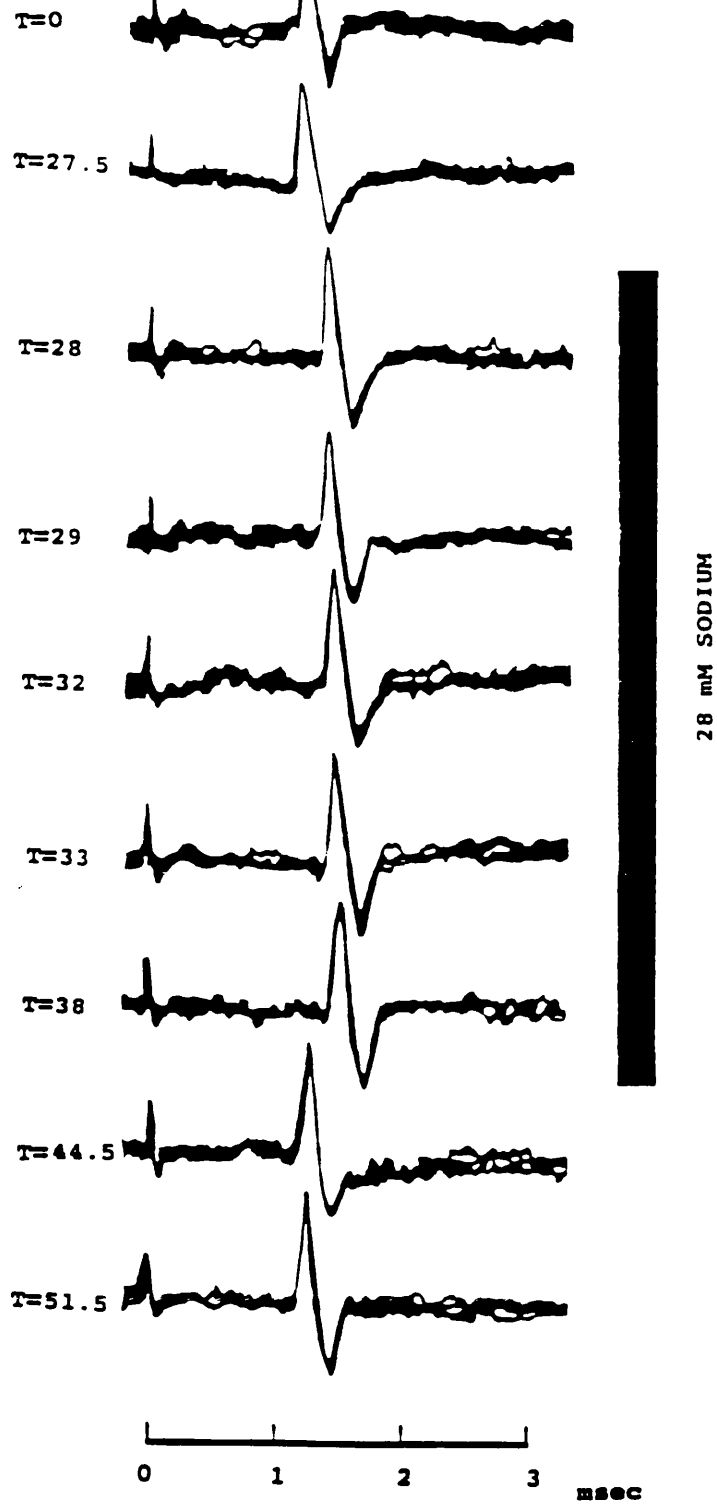

Figure 37

An action potential recorded from the isolated frog sciatic nerve. Conduction velocity is stable during perfusion with normal Ringer but rapidly falls when low sodium (28 mM) perfusion is initiated, indicated by the bar. Conduction velocity returns to normal following re-perfusion with normal Ringer (retouched).

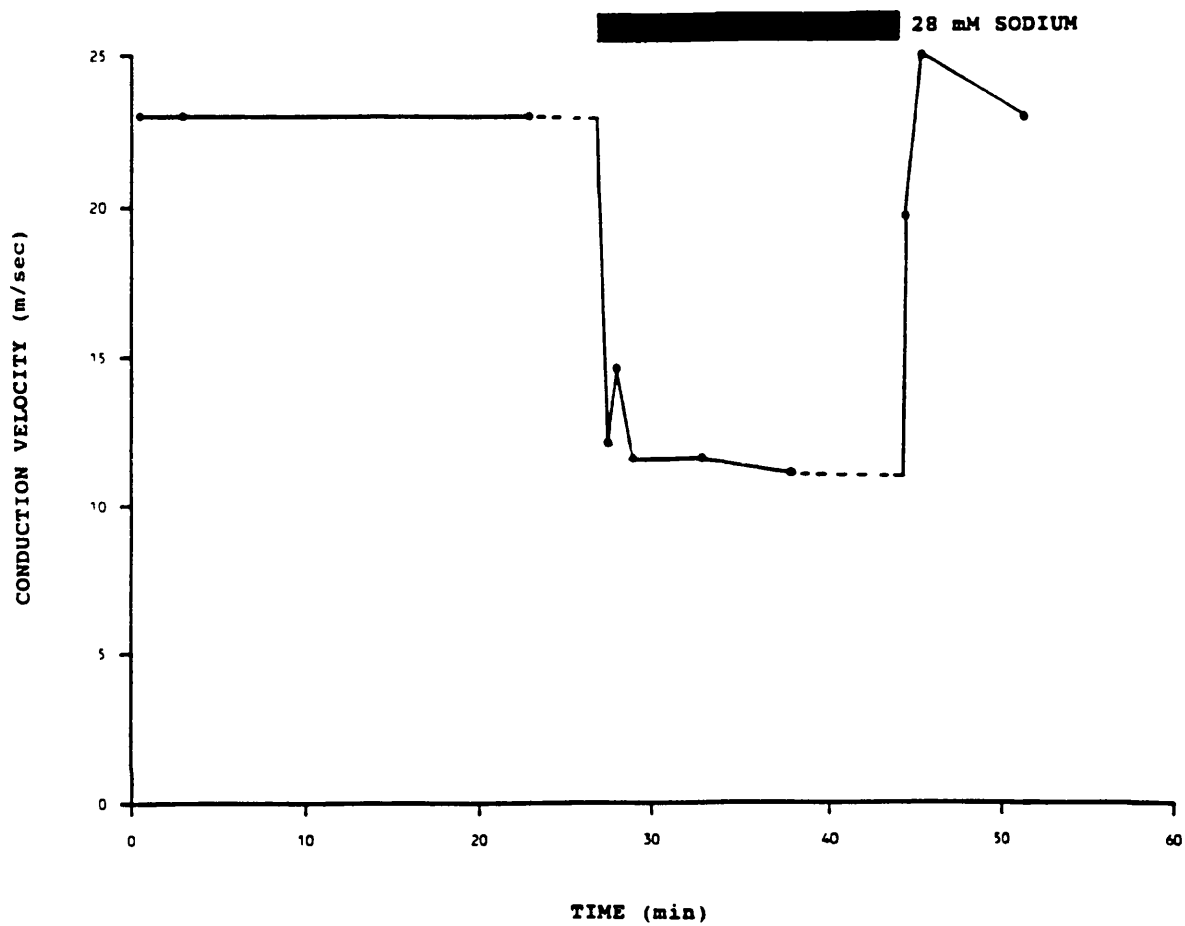

Figure 38

Plot of conduction velocity against time for the action potential shown in Figure 37. Low sodium perfusion is indicated by the bar and induces a stepwise change in velocity. Broken lines have been extrapolated from the data.

produces a step fall in conduction velocity, from 23 to 11 m/sec (a 52.2% drop). In a total of 78 action potentials recorded under these conditions, and which did not suffer conduction block, conduction velocity fell by an average of 60.1% (\pm SE=1.2).

In Figure 39 the fall in conduction velocity of these action potentials is correlated against their initial conduction velocity. Conduction velocity has been grouped into 5 m/sec bins and the average conduction slowing within each decade is shown. A line has been drawn by eye to fit the data and it appears that the slowest action potentials, with conduction velocities below 10 m/sec, suffer the largest degree of conduction slowing in the low sodium solution. Conduction velocity is slowed by an average of 69.1% (\pm SE=2.8) in the slowest group of axons ($n=11$), which compares to average slowing of 58.3% (\pm SE=1.2) in axons conducting faster than 10 m/sec ($n=67$). These values are significantly different ($P<0.001$, t-test).

It appears from Figure 39 that fast conducting axons may also have a low average survival time. A statistical analysis reveals that although this may be true, the fast axons are only effected to a marginally greater degree than the rest of the axon population. Thus, axons conducting between 25-30 m/sec have an average survival time of 62.7 min and those conducting between 30-35 m/sec have an average survival time of 65.4 min. The survival time for axons conducting between 25-30 m/sec is significantly different from that of the rest of the axons (t-test, $P=0.04$).

The action potential shown in Figure 37 does not fail in the low sodium solution, but this was not always the case. 8% of action potentials recorded in this study failed in the 28 mM sodium Ringer. The tendency for action potentials to fail was also found to be correlated with initial conduction velocity. Figure 40 is a histogram showing the initial conduction velocity of surviving and failing action potentials. It can be seen that 5 out of 16 (31%) of action potentials with a conduction velocity less than 10 m/sec failed in the low sodium, while only 6 out of 72 (12%) of action potentials with a higher initial conduction velocity failed. It is notable that two of these latter six action potentials have high conduction velocities. This is possibly indicative of a somewhat lower than average safety factor in the very largest axons, as may also be indicated by Figure 39.

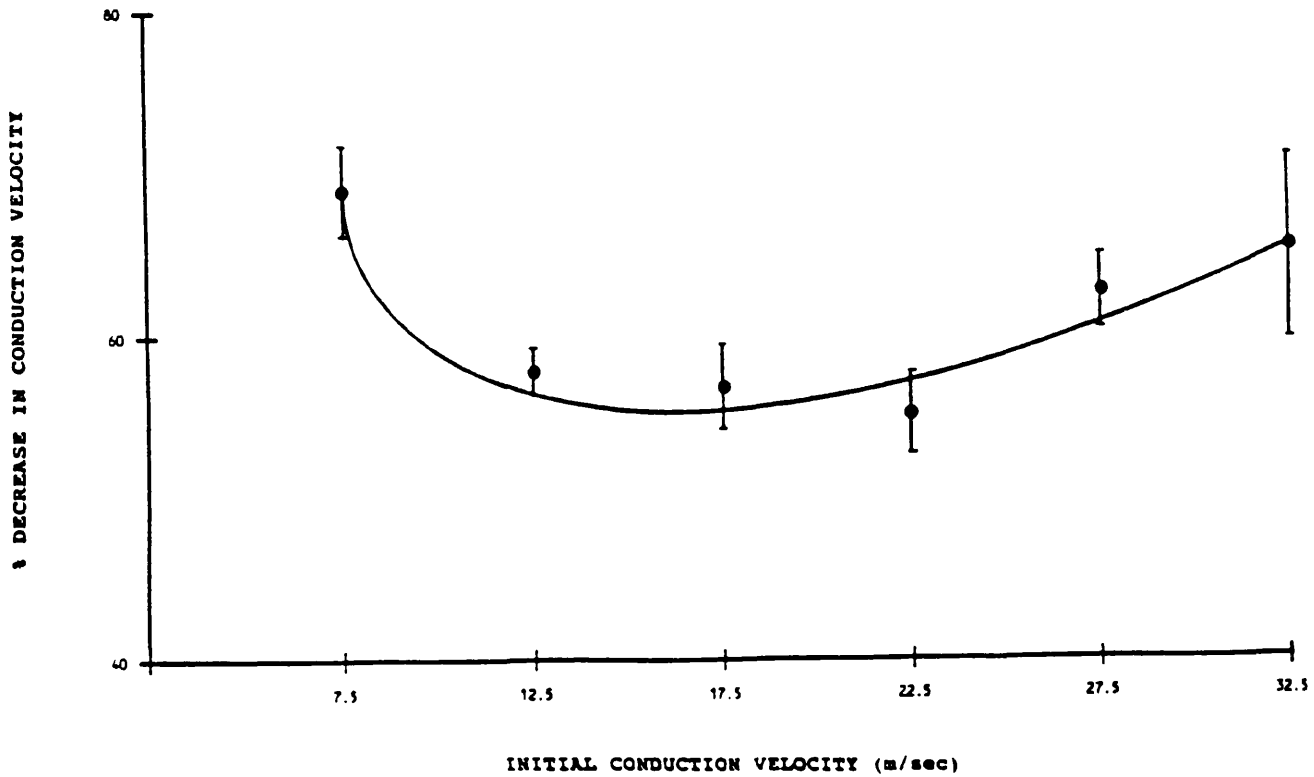

Figure 39

Plot of the average % decrease in conduction velocity of action potentials brought about by 28 mM sodium perfusion against initial conduction velocity, in 5 minute bins (the mid-point of each bin is indicated). Bars indicate Standard error. Note that the slower action potentials suffer the greatest average fall in conduction velocity.

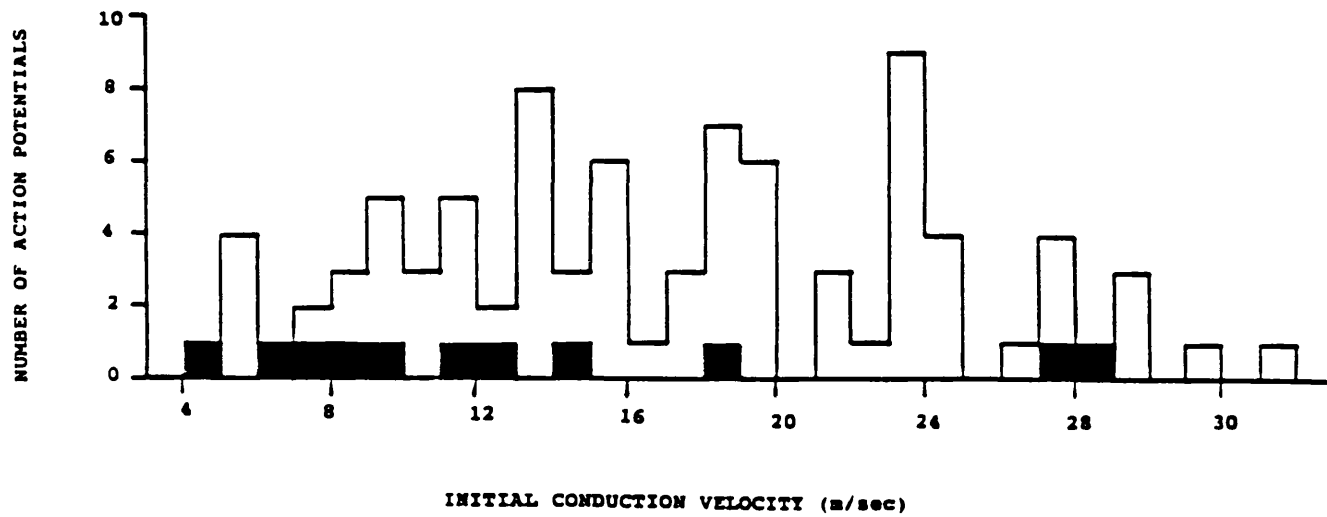

Figure 40

Histogram of action potential conduction velocity of potentials which failed (filled blocks) and those which survived (open blocks) low sodium perfusion. A total of 88 data are shown.

7. c. DISCUSSION

Perfusion with Ringer solution containing 25% of the normal sodium ion concentration produced conduction slowing or conduction block in all action potentials recorded (n=88). Action potentials with a conduction velocity of less than 10 m/sec were slowed by a significantly greater amount than faster conducting axons. In addition, 31% of action potentials conducting below 10 m/sec were blocked during 25% sodium perfusion while only 12% of potentials conducting faster than 10 m/sec failed in these conditions.

Hardy (1973 a, b) has investigated the relationship between extracellular sodium concentration and conduction velocity in myelinated frog axons (*Rana pipiens*). His experimental findings show a nearly square root dependence of conduction velocity upon extracellular sodium (Hardy, 1973 a) thus;

$$\ln(\theta_1/\theta_2)=0.524 \ln ([Na^+]_1/[Na^+]_2)+0.003$$

where θ is conduction velocity at sodium concentrations 1 and 2. Using this equation conduction velocity can be predicted to fall by 53% when sodium concentration is changed from 118 mM to 28 mM. This is in fair agreement with the value of 60.1% observed in the current results, considering possible species differences and the sampling bias towards faster conducting axons recognised by Hardy. Thus, only 5% of the axons recorded by Hardy had a conduction velocity less than 10 m/sec, compared to 18% in the current data set.

There have previously been relatively few experimental studies of the dependence of safety factor upon conduction velocity. The only study based upon recording distinct action potentials is that of Uehara (1958), where the specific blocking concentration of low sodium ion was related to axon diameter. This analysis indicated, as does the current investigation, that small, slow conducting, myelinated axons are not well equipped to survive low sodium conditions. It was concluded that small myelinated axons have a low factor.

However, due to the difficulty of the experimental technique adopted by Uehara

(1958), and the notorious problems of recording from single small diameter axons, her conclusions were based upon only a very small data sample (only 3 small diameter axons). Similar conclusion to Uehara's (1958) were drawn by Nathan and Sears (1962), also following low sodium perfusion. This study, however, was based upon compound action potential recordings, which can produce problematical results (see chapter 8).

The contribution made by the current chapter is to apply the unitary potential recording technique which allows the collection of a significant amount of data from axons of all diameters, while avoiding the problems associated with compound action potential recording. The current study has the additional advantage of allowing two assessments of the relationship between safety factor and initial conduction velocity, ie. the tendency to both conduction slowing and conduction block has been analyzed.

7. c. 1. *Low sodium perfusion is a good method of investigating safety factor.*

Safety factor can be defined as the current generated by an action potential divided by the current threshold for action potential activation (Rushton, 1937; Tasaki, 1959). Taking into account the cable properties of the internodal region, it is the potential that *arrives* at the node of Ranvier neighbouring the active node that is important, relative to threshold.

Lowering the extracellular sodium concentration will result in a lower emf for sodium ion entry ($E_m - E_{Na}$), following a reduction in sodium reversal potential (equation 3). The inward sodium current which underlies the rising phase of the action potential will therefore be reduced under these conditions as;

$$(5) \quad I_{Na} = G_{Na} \cdot (E_m - E_{Na})$$

(Hodgkin and Huxley, 1952 a) where; I_{Na} = sodium current, G_{Na} = sodium conductance, E_m = membrane potential: and action potential amplitude will be reduced as a result. This will only have a greater effect upon a particular group of axons if they have a low safety factor. Thus, axons with a low nodal membrane sodium conductance, low membrane potential or high intracellular sodium ion concentration will not be well equipped for action potential conduction in a low sodium ion environment. In addition, axons that have a low safety factor for other reasons, eg. inappropriate internodal cable

properties, will be susceptible to the reduction in action potential amplitude produced by low sodium perfusion. This technique of investigating safety factor has been used previously by Nathan and Sears (1962).

7. c. 2. The results agree with a theoretical account

A theoretical account of low safety factor in peripheral myelinated axons has been propounded by Chui and Ritchie (1984). These authors amended the dimensional analysis of Rushton (1951), to account for the observation that Schwann cells have a minimum average length (Ritchie, 1982), and that scaling between diameter and internodal distance therefore breaks down in small axons. With this amendment, a dimensional analysis predicts that axons with a diameter of less than 4μ will have a low safety factor. In frog axons the relationship between diameter and conduction velocity is less steep than in mammalian axons, and a diameter of 4 microns corresponds to a conduction velocity of slightly less than 10 m/sec (Hutchinson *et al.* 1970). The theoretical considerations of Chui and Ritchie (1984) therefore correspond well with the current results.

7. c. 3. Relevance of current findings

It is surprising that the relationship between axon conduction velocity and safety factor has not attracted more attention previously. As has been pointed out by Chiu and Ritchie (1984), a low safety factor in small myelinated axons, as they predicted and as has been found in the current chapter, is significant as it may account for the analgesic properties of local anaesthetics.

Local anaesthetics inhibit sodium conductance (Hille, 1966) and, therefore, will have a differential effect upon axons with a low safety factor (Nathan and Sears, 1961). As small myelinated axons are important in pain mediation (Landau and Bishop, 1953; Collins, Nulsen and Randt, 1960; Torebjörk and Hallin, 1973; Mackenzie, Burke, Skuse and Lethlean, 1975) and have a low safety factor, amelioration of pain following application of local anaesthetics, with continuity of non-nociceptive sensation, can be explained.

CHAPTER 8

**CHANGES IN COMPOUND ACTION POTENTIAL SHAPE DURING NERVE
CONDUCTION BLOCK**

8. 1. INTRODUCTION

The majority of the results in this thesis have been obtained by recording unitary action potentials. Thus, distinct action potentials have been recorded which exhibit all or none recruitment as the stimulus voltage was varied. Such unitary action potentials correspond to electrical activity in single nerve fibres and, therefore, represent only a tiny fraction of the total nerve fibre population, which number over 1,000 myelinated axons in the amphibian sciatic nerve (Gasser and Erlanger, 1927; Egar and Singer, 1971).

In Section I of this thesis the distribution of conduction block within the nerve fibre population was assessed by recording a small number of unitary action potentials in a large number of experiments. An alternative technique would be to record compound action potentials, rather than unitary action potentials. This technique was in fact used to verify some of the results obtained in section I.

Compound action potentials result from the synchronous discharge of individual action potentials in a large number of nerve fibres (Gasser and Erlanger, 1927; Gasser and Grundfest, 1939; Buchthal and Resenfalck, 1966; Cummins, Perkel and Dorfman, 1979; Olson and Bement, 1981; Stegeman and De Weerd, 1982 a, b; Dorfman, 1984). The different groups of nerve fibres (eg. A α , A β , etc) have different diameters and generate peaks at distinct locations in the compound action potential recording (Gasser and Erlanger, 1927). The amplitude of these peaks can be monitored and relative changes between them have been used to indicate the specific block of a group of axons (Gasser and Erlanger, 1929).

This approach represents a simple method for assessing conduction changes within peripheral nerve. A number of studies, many of them recent, have therefore employed compound action potential recording to examine differential conduction block (eg. Gissen, Covino and Gregus, 1980, 1982; Ford, Raj, Singh, Regan and Ohlweiler, 1984; Eickhorn, Haverkamp and Antoni, 1886; Dahlin *et al.* 1989).

As some of these studies have significant clinical implications, and as some compound action potentials have been used in this thesis, an experimental evaluation of the usefulness of compound action potential recording for the examination of differential nerve block is appropriate.

In the current chapter, changes in compound action potentials have been produced by either cooling, anaesthetizing or compressing the isolated frog sciatic nerve. These changes have then been compared to the known effects of cold, local anaesthetic and pressure as determined by previous unitary action potential recordings. This analysis indicates that changes in compound action potentials are useful for qualitative examination of differential nerve block, eg. for comparing two experimental conditions. However, the results highlight the difficulties in extrapolating from changes in compound action potential shape to detect conduction block of a specific group of axons. These difficulties might be avoided by using appropriate control experiments, as have been lacking in the past.

8. 2. RESULTS.

It was found in chapter 3 that the order of conduction block brought about by compression of frog nerve is dependant upon the degree of compression applied. Thus, a high degree of compression has a greater effect upon slow myelinated axons while a lower degree of compression has a greater effect upon faster axons. The changes in the compound action potential brought about by both high and low compression are illustrated in Figure 41 (the same as Figure 12, chapter 3).

On the left of Figure 41 are two series of compound action potentials. At time zero in both cases the fast A alpha and slower A beta components of the potentials are clear. Following the onset of compression the potentials become progressively smaller as the underlying action potentials are subject to conduction slowing and conduction block.

The extent of differential changes in the compound action potential, in terms of the amplitude of the two components, is illustrated on the right of Figure 41 for a total of five experiments. The ratio of the amplitude of the alpha and beta components is plotted against the fall in the amplitude of the alpha component. Thus, the negative slope found in the data for low compression indicates a differential suppression of the alpha component, as would be expected from the unitary action potential data presented in chapter 3. Conversely, high compression is found to differentially affect the beta component, as is also predicted from chapter 3.

Figure 41

Same as Figure 12. On the left are two series of compound action potentials recorded from the isolated frog sciatic nerve during compression, on the far left during 100 mmHg pressure to the right during 300 mmHg pressure. The two sets of records are superimposed at the bottom. On the far right, the ratio of the height of the alpha component divided by the height of the beta component is plotted against the fall in height of the alpha component. Data for low (broken line, $n=2$) and high (solid line, $n=3$) compression is shown.

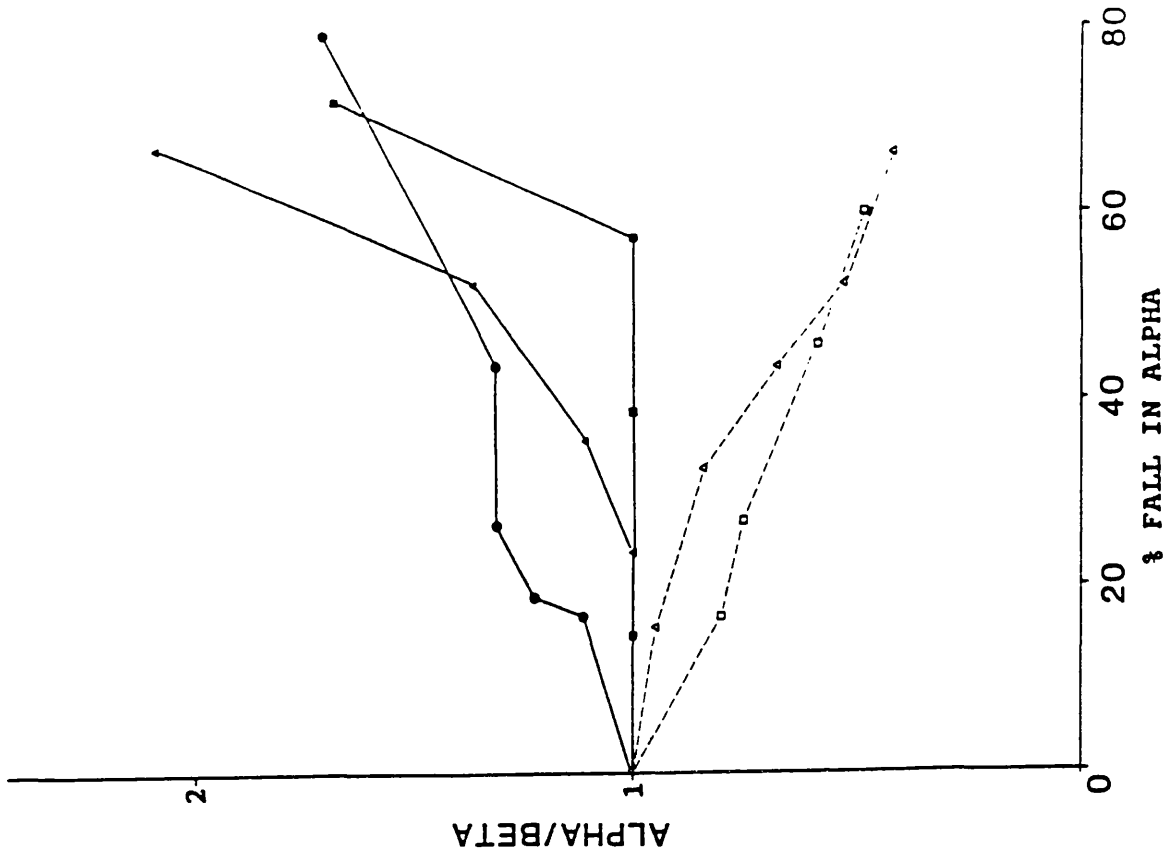
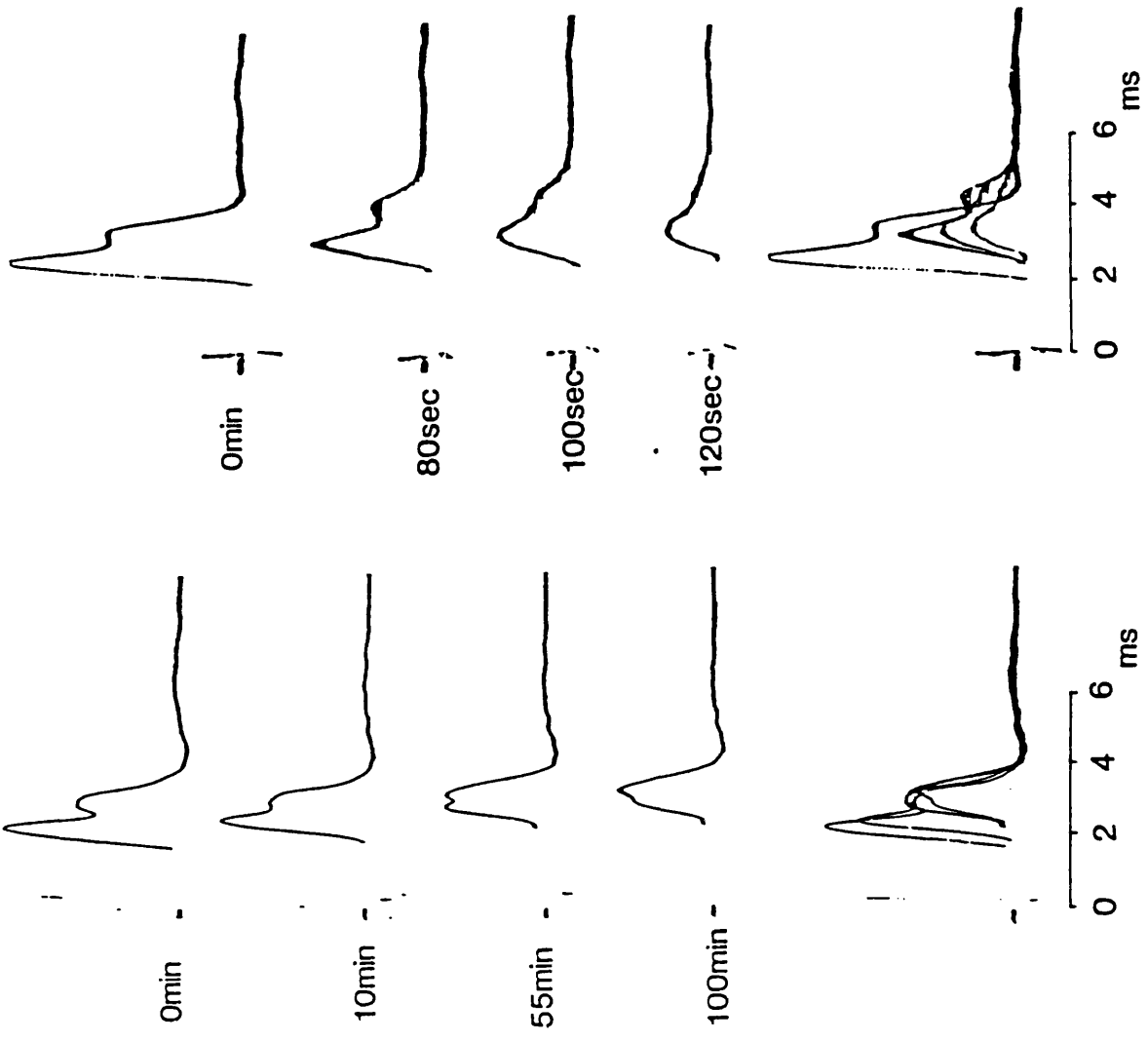

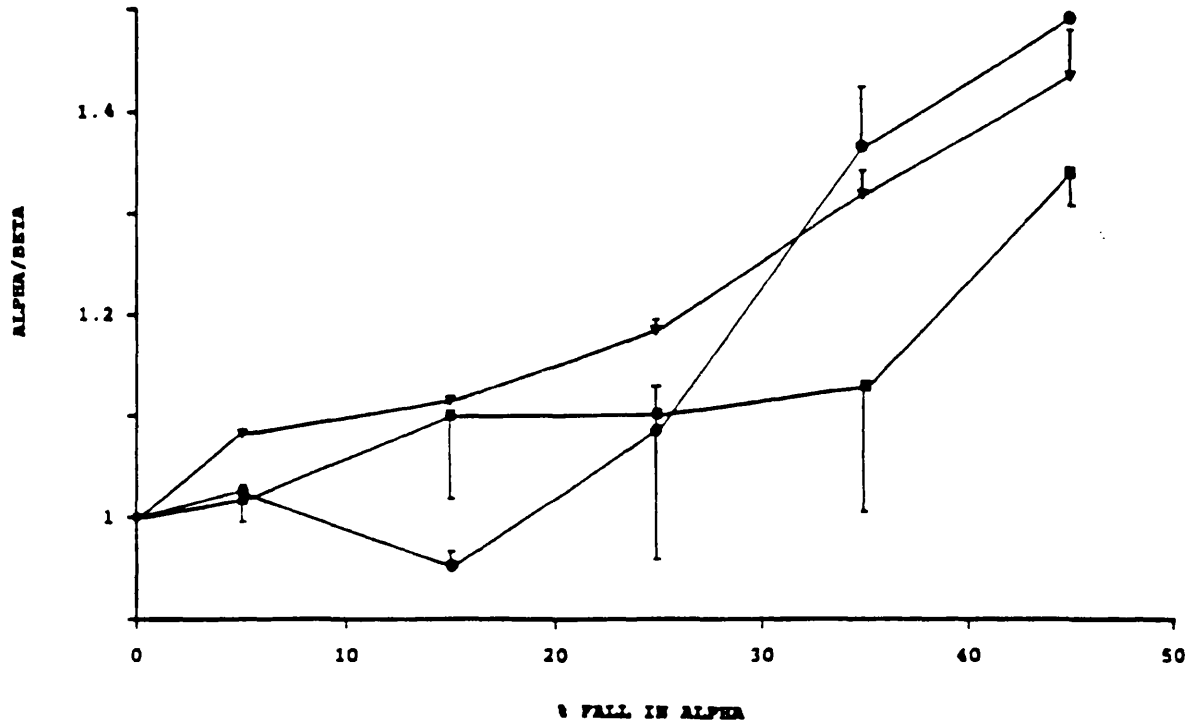

Figure 42

A plot of the ratio of alpha amplitude / beta amplitude against the fall in alpha amplitude during 1 % procaine Ringer (circles, n=6) and cooled Ringer (triangles, n=10) perfusion. The data from high compression experiments is also included (squares, n=3). Error bars = +/-SEM. Note that all three conditions produce a similar affect.

Figure 42 is a similar plot for data taken from 10 experiments in which frog sciatic nerves were cooled and 6 in which the nerve was perfused with 1% procaine Ringer solution (average changes are shown). Procaine perfusion is known to have a specific action upon slow myelinated axons (Franz and Iggo, 1968) and suppresses the slow component of the compound action potential more than the fast component. Cooling, however, has no differential actions upon myelinated axons (Paintal, 1965; Franz and Perry, 1973), yet has a distinctly differential effect upon the beta component of the compound action potential. The average data from the high compression experiment is also included in Figure 42. All three conditions appear to produce very similar responses.

8. 3. DISCUSSION

During the rising phase of an action potential current flows from the extracellular space into the axon. Electrodes on the surface of a nerve branch can register this current, if it is large compared to the conductance of the matrix surrounding the axon. Thus, the extracellular resistance must be high for a small current to produce a recordable potential change. As a result single action potentials can be recorded from small nerve branches where only a small amount of tissue surrounds the axon and the extracellular resistance is correspondingly high.

In nerve trunks with a large cross sectional area a large amount of current must flow into the inter-axonal compartment for a potential change to be recorded from the trunk surface. As a result single action potentials cannot be recorded well from large nerve trunks. However, when the rising phase of a number of action potentials occurs concurrently in a nerve trunk the total amount of current flowing into axons becomes significant and a potential change can be recorded. This is the compound action potential.

Thus, compound action potentials arise when a large number of nerve fibres discharge action potentials synchronously (Gasser and Erlanger, 1927; Gasser and Grundfest, 1939; Buchthal and Rosenfalck, 1966; Cummins, *et al.* 1979; Olson and Bement, 1981; Stegeman and De Weerd, 1982 a; Dorfman, 1984). That the action potentials are synchronous is critical to the amplitude of the compound action potential,

and the amplitude falls when the underlying action potentials become dispersed, for example by increasing the conduction distance (Gasser and Erlanger, 1927: Figure 11; Stegeman and De Weerd, 1982 a; Olney and Miller, 1983; Wiechers and Fatehi, 1983; Olney, Budingen and Miller, 1987).

It can be predicted that block of a particular group of axons will simply eliminate the corresponding peak of the compound action potential. However, with the exception of a point transection of an axon (axonotmesis) conduction block is always preceded by a degree of conduction slowing. The amount of slowing will scale with the length of nerve being blocked and will, in itself, produce changes in the compound action potential due to the dispersion of the underlying single action potentials.

The results appear to suggest that changes in the compound action potential accurately reflect conduction block of either fast or slow myelinated axons. Thus, both procaine perfusion and relatively severe compression of the nerve trunk had a greater effect upon the slower of the two compound action potential components, while unitary action potential studies have shown that these two conditions actually have specific actions upon slower conducting myelinated axons (current chapter 3; Franz and Perry, 1973; Fern and Harrison, 1991 a). Less severe compression, known to have a greater effect upon faster axons (current chapter 3; Fern and Harrison, 1991 a), had the opposite effect, suppressing the fast component of the compound action potential to the greater degree.

Such changes in the compound action potential are, however, of a qualitative nature only and could not be used to *determine* the effects of a previously untested condition. For example, a difference between high and low compression is clearly demonstrated by the results but cannot be taken to mean that low compression blocks fast axons and high compression blocks slow axons on the basis of compound action potential experiments alone. This conclusion must be drawn because cooling, which has no differential actions upon nerve fibres of different diameter, had the same effect as high compression, ie. a specific action upon the beta component.

A similar observation regarding nerve cooling was made by Paintal (1965). In his experiments it was demonstrated that individual cat myelinated axons were all equally effected by cooling, yet the A delta component of the compound action potential was lost more quickly during cooling than faster compound action potential components,

as also noted by Douglas and Malcolm (1955). Paintal attributed this to the greater dispersion of slow action potentials which will accompany conduction block. Thus, slowly conducting action potentials undergo a larger increase in conduction latency during a given amount of conduction slowing, compared to fast action potentials. A barrage of slow action potentials will therefore be disrupted to a greater extent, and the amplitude of the corresponding compound action potential peak suppressed more, than in a corresponding barrage of fast action potentials, during conduction block.

It also follows that the differential effect of procaine upon the slow compound action potential component cannot be taken to indicate a specific block of slow axons, as the effects of procaine and cooling cannot be distinguished. This would be explained if procaine only has a differential action upon the very slowest myelinated axons, as may be the case (Franz and Perry, 1973: Figure 4; Chiu and Ritchie, 1984; current chapter 7). As the slowest myelinated axons do not contribute to the alpha and beta components of the compound action potential, the differential action of procaine upon the slow component may be artefactual, as it must be during cooling.

A reasonable conclusion is that the rapid decline of the beta component of the compound action potential during three out of the four types of conduction block employed in this chapter does not result from block of conduction of A beta action potentials, but represents the normal behaviour of the compound action potential under conditions which slow nerve conduction. Only low compression was found to have the opposite effect and differentially suppress the alpha component. This must indicate that high compression can overcome the compound action potentials apparent natural bias towards loss of the beta component. That the relationship between conduction velocity and survival time is relatively steep during high compression, and corresponds to the full range of conduction velocities, may explain this.

Recent studies of differential nerve block that have relied upon compound action potentials can be separated into those that have reported qualitative changes, for example assessing relative differences in the actions of various local anaesthetics (Gissen, *et al.* 1982; Ford *et al.* 1984) and those reporting quantitative results, for example demonstrating a reputedly specific block of a group of axons (Gissen, *et al.* 1980; Eickhorn, *et al.* 1986; Dahlin, *et al.* 1989).

It must be concluded from the current results that while qualitative assessments

of differential effects using compound action potentials may be useful, quantitative conclusions cannot be drawn from such data. This shortcoming could be removed if a significantly greater effect than that produced simply by the uniform dispersion of action potentials could be demonstrated.

CONCLUSION TO SECTION II

In the introduction to this section it was suggested that the complex structure and membrane organisation of the axon will have consequences for the axons response to changes in ionic environment. The results are consistent with this view.

It was found that changing the concentration of ions which have little influence upon the membrane potential produces simple, stepwise, changes in action potential conduction velocity. Raising the potassium ion concentration, however, engendered a more complex response, often involving fast and slow components. Extracellular potassium ion concentration has a great influence upon membrane potential and it appears that high potassium induces potential changes over different time courses in different regions of the axon.

Depolarisation of the nodal axolemma is rapid following high potassium perfusion and results in a rapid fall in conduction velocity. The internodal region, however, apparently exhibits a very slow depolarisation in high potassium. Despite the slow time course of this affect it can result in profound changes in action potential conduction.

A consequence of the slow rate at which potassium accumulates beneath the myelin sheath is that axons will continue to function for long periods within regions of high potassium concentration. Taken with other recent findings the current results suggest that potassium ion homeostasis beneath the myelin sheath is an important event in axons.

Low extracellular sodium does not depolarise the axolemma and has its actions upon conduction velocity by reducing current flow through sodium channels. Action potential amplitude is reduced as a result and the ratio between action potential amplitude and action potential threshold falls. Low sodium therefore brings about a simple reduction in safety factor and axons found to be greatly influenced by this must be considered to have a low security of conduction.

It was found that the very slowest myelinated axons, ie. those with a conduction velocity below 10 m/sec, are most affected by low sodium and must therefore be the axons with the lowest safety factor. This result confirms an earlier theoretical proposal and may explain why small myelinated axons, known to be nociceptive in function,

are so easily blocked by local anaesthetics.

These results describing conduction velocity changes were achieved by recording single action potentials. There are, in fact, three techniques that allow the study of peripheral nerve conduction block: 1) the functional consequence of block can be examined, for example using clinical tests; 2) the potential generated by discharge of a large number of axons can be recorded during block or; 3) the response of individual axons can be monitored during block. The majority of the results in this thesis are of the third type, which is free from many of the variables which complicate the interpretation of results obtained with the other two techniques.

However, the second type of assessment, compound action potential recording, is technically simpler than recording single axon responses and is widely used for the kind of study reported in this thesis. It was found in the results that compound action potentials can produce useful results when employed to examine the differences between two conditions. However, compound action potentials might indicate a specific block of slow axons even when no such event is occurring. The compound action potential technique, therefore, must be considered as inappropriate for detecting the differential block of axons.

APPENDIX I.

SUMMARY OF IONIC CHANNEL DISTRIBUTIONS IN THE FROG
MYELINATED AXON AND COMPARISON TO THE MAMMALIAN
MYELINATED AXON.

The distribution of the various ionic channels identified in the frog myelinated axon are summarised in table 3. Potassium channel density is about 20 times higher in the node compared to the internode, and a significant TEA insensitive slow potassium conductance is present within the internode, but not the node (Grissmer,1986). The highest density of the sodium channels is in the node, with only 0.2% of the nodal density occurring in the internode (Grissmer,1986).

TABLE 3

| CHANNEL | NODE | INTERNODE | REFERENCE |
|----------|------|-----------|-----------------------------|
| G_{KF} | 80% | ----- | DUBOIS (1981) |
| | 85% | 67% | GRISSMER (1986) |
| G_{KS} | 20% | ----- | DUBOIS (1981) |
| | 15% | 33% | GRISSMER (1986) |
| IR | | MAJORITY | BOSTOCK and GRAFE (1986) |

(G_{KF} =fast potassium channels (both G_{KF1} and G_{KF2}), G_{KS} =slow potassium channels, IR=inward rectifier).

A dissimilar arrangement of similar conductances has been found in mammalian axons. Potassium conductance is small in the mammalian node and early reports often failed to find it at all (Horackova, Nonner and Stämpfli, 1968; Chiu, Ritchie, Rogart and Stagg, 1979; Brismar, 1980). However, Chui and Ritchie (1981; 1982) identified potassium channels in the internode, which have since been shown to have a functional role (Baker *et al.* 1987).

Binah and Palti (1982) and Brismar and Schwarz (1985) did find potassium channels in the node which Röper and Schwarz (1989) have since distinguished into fast

and slow channels. Slow potassium channels form 75% of the nodal potassium conductance and less than 5% in the internode, while fast potassium channels were found in greatest density in the paranodal region. Röper and Schwarz (1989) also found evidence that the fast potassium conductance could be dissociated into two components, as in the frog.

Baker *et al.* (1987) and Eng *et al.* (1990) have found an inward rectifying potassium conductance in mammalian axons. The mammalian inward rectifier is both TEA and 4-AP insensitive, while the slow and fast mammalian potassium currents have a very similar pharmacology to the corresponding currents in the frog (Baker *et al.* 1987; Black *et al.* 1989; Röper and Schwarz, 1989).

Thus, ionic channel types are very similar in frog and mammalian myelinated axons, but are distributed differently. In particular, slow potassium channels form the majority of the mammalian axon potassium conductance but only a minority in that of the frog, while slow channels are in their highest density within the internode of the frog but are mainly restricted to the nodes of mammalian axons.

The precise behaviour of mammalian axons during changes in ionic environment is therefore unlikely to be identical to those reported in this thesis for the frog. However, a significant potassium conductance is present within the internodal region of the mammalian myelinated axon (Baker *et al.* 1987; Röper and Schwarz, 1989), and qualitatively similar findings to those found during high potassium perfusion should thus be expected.

REFERENCES

- ADELMAN, W.J. & PALTÍ, Y. (1969). The influence of external potassium on the inactivation of sodium currents in the giant axon of the squid, *Loligo pealei*. *Journal of General Physiology* **53**, 685-703.
- ADRIAN, E.D. & ZOTTERMAN, Y. (1926). The impulses produced by sensory nerve endings. II. The response of a single end organ. *Journal of Physiology* **61**, 151-171.
- AGUAYO, A., NAIR, C.P.V., & MIDGLEY, R. (1971). Experimental progressive compression neuropathy in the rabbit. *Archives of Neurology* **24**, 358-365.
- AHO, K., SAINO, K., CHIANTA, M. & VARPANEN, E. (1983). Pneumatic tourniquet paralysis. *Journal of Bone and Joint Surgery* **65**, 441-443.
- AIDLEY, D.J. (1978). *The Physiology of Excitable Cells*. 2nd edition. Cambridge University Press, Cambridge.
- ALDINI, G. (1794). *De animalí electricitate dissertationes duae*. Bologna. In Brazier (1984).
- ANDERSON, M.H., FULLERTON, P.M., GILLIATT, R.W. & HERN, J.E. (1970). Changes in the forearm associated with median nerve compression at the wrist in the guinea-pig. *Journal of Neurology, Neurosurgery, and Psychiatry* **33**, 70-79.
- ÅRHEM, P., FRANKENHAEUSER, B. & MOORE, L.E. (1973). Ionic currents at resting potential in nerve fibres from *Xenopus laevis*. Potential clamp experiments. *Acta Physiologica Scandinavica* **88**, 446-454.
- BAKER, M., BOSTOCK, H., GRAFE, P. & MARTIUS, P. (1987). Function and distribution of three types of rectifying channel in rat spinal root myelinated axons. *Journal of Physiology* **383**, 45-67.

BARRETT, E.L. & BARRETT, J.N. (1982). Intracellular recording from vertebrate myelinated axons: mechanism of the depolarizing afterpotential. *Journal of Physiology* **323**, 117-144.

BARRETT, E.L., MORITA, K. & SCAPPATICCI, K.A. (1988). Effects of Tetraethylammonium on the depolarising afterpotential and passive properties of lizard myelinated axons. *Journal of Physiology* **402**, 65-78.

BELL, M.A. & WEDDELL, A.G.M. (1984 a). A morphometric study of intrafascicular vessels of mammalian sciatic nerve. *Muscle and Nerve* **7**, 524-534.

BELL, M.A. & WEDDELL, A.G.M. (1984 b). A descriptive study of the blood vessels of the sciatic nerve in the rat, man and other mammals. *Brain* **7**, 871-898.

BENTLEY, F.H. & SCHLAPP, W. (1943 a). Experiments on the blood supply of nerve. *Journal of Physiology* **102**, 62-71.

BENTLEY, F.H. & SCHLAPP, W. (1943 b). The effects of pressure on conduction in peripheral nerve. *Journal of Physiology* **102**, 72-82.

BERGMAN, C., NONNER, W. & STÄMPFLI, R. (1968). Sustained spontaneous activity of ranvier nodes induced by the combined actions of TEA and lack of calcium. *Pflügers Archive* **302**, 24-37.

BERNSTEIN, J. (1902). Untersuchungen zur Thermodynamik der bioelektrischen Ströme. *Pfluegers Archive* **92**, 521-562. In Tasaki (1982).

BERNSTEIN, J. (1912). *Elektrophysiologie*. Brunschweig. In Brazier (1988).

BERTHOLD, C.H. (1978). Morphology of normal peripheral axons. In *Physiology and Pathobiology of Axons*, ed. Waxman, S.G. Raven Press, New York.

BINSTOCK, L. & GOLDMAN, L. (1969). Current and voltage clamped studies of *myxicola* giant axons. *Journal of General Physiology* **54**, 730-739.

BLACK, J.A., KOCSIS, J.D. & WAXMAN, S.G. (1990). Ion channel organisation of the myelinated fibre. *Trends in Neuroscience* **13**, 48-54.

BLIGHT, A.R. (1985). Computer simulation of action potentials and afterpotentials in mammalian myelinated axons: the case for a lower resistance myelin sheath. *Neuroscience* **15**, 13-31.

BLIGHT, A.R. & SOMEYA, S. (1985). Depolarising afterpotential in myelinated axons of the mammalian spinal cord. *Neuroscience* **15**, 1-12.

BLUNT, M.J. (1960). Ischaemic degeneration of nerve fibres. *Archives of Neurology* **2**, 528-536.

BLUNT, M.J. & STRATTON, K. (1956). The immediate effects of ligature of the vasa nervorum. *Journal of Anatomy* **90**, 204-216.

BOSTOCK, H., BAKER, M., GRAFE, P. & REID, G. (1991 a). Changes in excitability and accommodation of human motor axons following periods of ischaemia. *Journal of Physiology* **441**, 513-535.

BOSTOCK, H., BAKER, M. & REID, G. (1991 b). Changes in excitability of human motor axons underlying post-ischaemic fasciculations: Evidence for two stable states. *Journal of Physiology* **441**, 537-557.

BOYD, I.A. & DAVEY, M.R. (1968). *Composition of peripheral nerves*. E & S Livingstone Ltd, London.

BOYLE, P.J. & CONWAY, E.J. (1941). Potassium accumulation in muscle and associated changes. *Journal of Physiology* **100**, 1-63.

BRAZIER, M.A.B. (1984). A History of Neurophysiology in the 17th and 18th Centuries. Raven Press, New York.

BRAZIER, M.A.B. (1988). A History of Neurophysiology in the 19th Century. Raven Press, New York.

BRUNER, J.M. (1951). Safety factors in the use of the pneumatic tourniquet of the hand. *Journal of Bone and Joint Surgery* **33A**, 221-224.

BUCHTHAL, F. & ROSENFALCK, A. (1966). Evoked action potentials and conduction velocity in human sensory nerves. *Brain Research* **3**, 1-122.

BURKE, J. (1978). *Connections*. Macmillan, London.

BURKE, W., BURNE, J.A. & MARTIN, P.R. (1985). Selective block of Y optic nerve fibres in the cat and the occurrence of inhibition in the lateral geniculate nucleus. *Journal of Physiology* **364**, 81-92

BURKE, W., COTTEE, L. J., GARVEY, J., KUMARASINGHE, R. & KYRIACOU, C. (1986). Selective degeneration of optic nerve fibres in the cat produced by a pressure block. *Journal of Physiology* **376**, 461-476.

CAUSEY, G. (1948). The effects of pressure on nerve fibres. *Journal of Anatomy* **82**, 262-269.

CAUSEY, G. & PALMER, E. (1949). The effects of pressure on nerve conduction and nerve fibre size. *Journal of Physiology* **109**, 220-231.

CHIU S.Y. (1982). Resting potential of a frog myelinated axon: the role of the internode. *Society for Neuroscience Abstracts* **8**, 253.

CHIU, S.Y. & RITCHIE, J. M. (1981). Evidence for the presence of potassium channels in the paranodal region of acutely demyelinated mammalian myelinated nerve fibres. *Journal of Physiology* **313**, 415-437.

CHIU, S.Y. & RITCHIE, J. M. (1982). Evidence for the presence of potassium channels in the internode of frog myelinated nerve fibres. *Journal of Physiology* **322**, 485-501.

CHIU, S.Y. & RITCHIE, J.M. (1984). On the physiological role of internodal potassium channels and the security of conduction in myelinated nerve fibres. *Proceedings of the Royal Society* **220**, 415-422.

CODY, F.W.J., GOODWIN, C.N. & RICHARDSON, H.C. (1987). Effects of ischaemia upon reflex electromyographic responses evoked by stretch and vibration in human wrist flexors. *Journal of Physiology* **391**, 589-609.

COLE, K.S. & CURTIS, H.J. (1939). Electrical impedance of the squid giant axon during activity. *Journal of General Physiology* **22**, 649-670.

COLLINS, W.F., NULSEN, F.E. & RANDT, C.T. (1960). Relation of peripheral nerve fibre size and sensation in man. *Archives of Neurology* **3**, 381-385.

CONWAY, E.J. (1957). Nature and significance of concentration relations of potassium and sodium in skeletal muscle. *Physiological Reviews* **37**, 84-132.

CRENSHAW, A.G., HARGENS, A.R., GERSHUNI, D.H. & RYDEVIK, B. (1988). Wide tourniquet cuffs: More effective deep tissue compression and loss of arterial pulse at lower inflation pressure. *Acta Orthopædica Scandinavica*

CUMMINS, K.L., PERKEL, D.H. & DORFMAN, L.J. (1979). Nerve fibre conduction-velocity distributions. 1. Estimation based on the single-fibre and compound action potentials. *Electroencephalography and Clinical Neurophysiology* **46**, 634-646.

CURTIS, H.L. & COLE, K.S. (1942). Membrane resting and action potentials in giant fibres of squid nerve. *Journal of Cellular and Comparative Physiology* **19**, 135-144.

DAHLIN, L.B., SHYU, B.C., DANIELSEN, N. & ANDERSSON, S.A. (1989). Effect of nerve compression or ischaemia on conduction properties of myelinated and non-myelinated nerve fibres. An experimental study in the rabbit common peroneal nerve. *Acta Physiologica Scandinavica* **136**, 97-105.

DAVID, G. BARRETT, J.N. & BARRETT, E.F. (1992). Evidence that action potentials activate an internodal potassium conductance in lizard myelinated axons. *Journal of Physiology* **445**, 277-301.

DAVIES, T.W. (1987). Relationship between the stretch reflexes of abductor digiti minimi and flexor carpi ulnaris in man. *Journal of Physiology* **384**, 35P.

DENNY-BROWN, D. & BRENNER, C. (1944 a). Paralysis of nerve induced by direct pressure and by tourniquet. *Archives of Neurology and Psychiatry* **51**, 1-26

DENNY-BROWN, D. & BRENNER, C. (1944 b) Lesion in peripheral nerve resulting from compression by spring clip. *Archives of Neurology and Psychiatry* **52**, 1-19

DIETZEL, I. & HEINEMANN, U. (1986). Dynamic variations of the brain cell microenvironment in relation to neuronal hyperactivity. *Annals of the New York Academy of Sciences* **481**, 72-84.

DODGE, F.A. & FRANKENHAEUSER, B. (1958). Membrane currents in isolated frog nerve fibre under voltage clamp conditions. *Journal of Physiology* **143**, 76-90.

DODGE, F.A. & FRANKENHAEUSER, B. (1959). Sodium currents in the myelinated nerve fibre of *Xenopus laevis* investigated with the voltage clamp technique. *Journal of Physiology* **148**, 188-200.

DORFMAN, L.J. (1984). The distribution of conduction velocities (DVC) in peripheral nerves: a review. *Muscle and Nerve* **7**, 2-11.

DUBOIS, J.M. (1981). Evidence for the existence of three types of potassium channels in the frog Ranvier node membrane. *Journal of Physiology* **318**, 297-316.

DU BOIS RAYMOND, E. (1848). Untersuchungen über thierische Electricität Reimer, 1848-1884. In Brazier (1988).

DOUGLAS, W.W. & MALCOLM, J.L. (1955). The effect of localized cooling on conduction in cat nerves. *Journal of Physiology* **130**, 53-71.

EAMES, R.A & LANGE, L.S. (1967). Clinical and pathological study of ischaemic neuropathy. *Journal of Neurology, Neurosurgery, and Psychiatry* **30**, 215-226.

EDWARDS, D.J. & CATTELL, M. (1928). Further observations on decrement in nerve conduction. *American Journal of Physiology* **87**, 359-367.

EGAR, M. & SINGER, M. (1971). A quantitative electron microscope analysis of peripheral nerve in the urodele amphibian in relation to limb regenerative capacity. *Journal of Morphology* **133**, 387-398.

EICKHORN, R., HAVERKAMPF, K. & ANTONI, H. (1986). Disturbances of neural conduction in isolated frog nerve following exposure to strong electric fields. *Muscle and Nerve* **9**, 313-318.

ELLIOTT, F. A. (1971). *Clinical Neurology*. W.B. Saunders Company; Philadelphia.

ENG, D., GORDON, T.R., KOCSIS, J.D. & WAXMAN, S.G. (1990). Current-clamp analysis of a time-dependent rectification in rat optic nerve. *Journal of Physiology* **421**, 185-202.

ERLANGER, J. and GASSER, H.S. (1924). The compound nature of the action current of nerve as disclosed by the cathode ray oscillograph. *American Journal of Physiology* **70**, 624-666.

ESLER, M., JENNINGS, G., LEONARD, P., SACHARIAS, N., BURKE, F., JOHNS, J. & BLOMBERY, P. (1984). Contribution of individual organs to total noradrenaline release in humans. *Acta Physiologica Scandinavica*, Supplement **527**, 11-16.

FERN, R. & HARRISON, P.J. (1988). Conduction slowing and conduction block induced by a high extracellular calcium concentration in isolated myelinated nerves of the frog (*Rana temporaria*). *Journal of Physiology* **406**, 77P.

FERN, R. & HARRISON, P.J. (1989). The sequence of pressure-induced conduction failure of myelinated fibres in the isolated frog sciatic nerve (*Rana temporaria*) is dependant upon the pressure applied. *Journal of Physiology* **418**, 77P.

FERN, R. & HARRISON, P.J. (1990 a). The contribution of ischaemia and axon deformation to conduction block induced by compression in the sciatic nerve of the anaesthetized cat. *Journal of Physiology* **426**, 44P.

FERN, R. & HARRISON, P.J. (1990 b). Ischaemic conduction block in relation to diameter and function. *Neuroscience Letters supplement* **38**, S33.

FERN, R. & HARRISON, P.J. (1991 a). The effect of compression upon conduction in myelinated axons of the isolated frog sciatic nerve. *Journal of Physiology* **432**, 111-122.

FERN, R. & HARRISON, P.J. (1991 b). The slow time course of conduction slowing in myelinated axons of the isolated frog sciatic nerve perfused with a high concentration of potassium ions. *Journal of Physiology* **434**, 50P.

FERTZIGER, A.P. & RANCK, J.B. (1970). Potassium accumulation in interstitial space during epileptiform seizures. *Experimental Neurology* **26**, 571-585.

FLATT, A. (1972). Tourniquet time in hand surgery. *Archives of Surgery* **104**, 190-192.

FOWLER, T.L., DANTA, G. & GILLIATT R.W. (1972). Recovery of nerve conduction after a pneumatic tourniquet: observations on the hind limb of the baboon. *Journal of Neurology, Neurosurgery, and Psychiatry* **35**, 638-647.

FORD, D.J., RAJ, P.P., SINGH, P., REGAN, K.M. & OHLWEILER, D. (1984). Differential peripheral nerve block by local anaesthetics in the cat. *Anesthesiology* **60**, 28-33.

FOX, J.M. (1976). Ultra-slow inactivation of the ionic currents through the membrane of myelinated nerve. *Biochemica et Biophysica Acta* **426**, 232-244.

FOX, L.J. & KENMORE, P.I. (1967). The effects of ischaemia on nerve conduction. *Experimental Neurology* **17**, 403-419.

FRANKENHAEUSER, B. (1949). Ischaemic paralysis of a uniform nerve. *Acta Physiologica Scandinavica* **18**, 75-98.

FRANKENHAEUSER, B. (1959). Steady state inactivation of sodium permeability in myelinated nerve fibres of *Xenopus laevis*. *Journal of Physiology* **148**, 671-676.

FRANKENHAEUSER, B. (1962). Potassium permeability in myelinated nerve fibres of *Xenopus laevis*. *Journal of Physiology* **160**, 54-61.

FRANKENHAEUSER, B. (1963 a). A quantitative description of potassium currents in myelinated nerve fibres of *Xenopus laevis*. *Journal of Physiology* **169**, 424-430.

FRANKENHAEUSER, B. (1963 b). The effect of temperature on the sodium and potassium currents permeability changes in myelinated nerve fibres of *Xenopus laevis*. *Journal of Physiology* **169**, 431-437.

FRANKENHAEUSER, B. (1963 c). Inactivation of the sodium-carrying mechanism in myelinated nerve fibres of *Xenopus laevis*. Voltage clamp experiments. *Journal of Physiology* **169**, 438-444.

FRANKENHAEUSER, B. (1964). Computed action potential in nerve from *Xenopus laevis*. *Journal of Physiology* **180**, 780-787.

FRANKENHAEUSER, B. & HODGKIN, A.L. (1957). The actions of calcium on the electrical properties of squid axons. *Journal of Physiology* **137**, 218-244.

FRANKENHAEUSER, B. & MOORE, L. E. (1963). The specificity of the initial current in myelinated nerve fibres of *Xenopus laevis*. Voltage clamp experiments. *Journal of Physiology* **169**, 438-444.

FRANKENHAEUSER, B. & HUXLEY, A.F. (1964). The action potential in the myelinated nerve fibres of *Xenopus laevis* as computed on the basis of voltage clamp data. *Journal of Physiology* **171**, 302-315.

FRANZ, D.N. & IGGO, A. (1968). Conduction failure in myelinated and non-myelinated axons at low temperature. *Journal of Physiology* **199**, 319-345.

FRANZ, D.N. & PERRY, R.S. (1974). Mechanisms for differential block among single myelinated and non-myelinated axons by procaine. *Journal of Physiology* **236**, 193-210.

FULLERTON, P.M. & GILLIATT, R.W. (1967 a). Pressure neuropathy in the hind foot of the guinea-pig. *Journal of Neurology, Neurosurgery, and Psychiatry* **30**, 18-25

FULLERTON, P.M. & GILLIATT, R.W. (1967 b). Medial and ulnar neuropathy in the guinea-pig. *Journal of Neurology, Neurosurgery, and Psychiatry* **30**, 393-402.

GALVANI, L. (1791). *Aloysii Galvani de veribus electricitatis in motu musculari. Commentarius. De veribus electricitatis artificialis in motu musculari. De Bononiensi Scientiarum et Artium Instituto atque Acedemia*, **7**, 363-418. In Brazier (1984).

GASSER, H.S. & ERLANGER, J. (1927). The role played by the sizes of the constituent fibres of a nerve trunk in determining the form of its action potential wave. *American Journal of Physiology* **80**, 522-547.

GASSER, H.S. & ERLANGER, J. (1929). The role of fibre size in the establishment of a nerve block by pressure of cocaine. *American Journal of Physiology* **88**, 581-591.

GASSER, H.S. (1943). Pain producing impulses in peripheral nerves. *Research Publications of the Association for Research into Nerve and Mental Diseases* **23**, 44-62.

GASSER, H.S. & GRUNDFEST, H. (1939). Axon diameters in relation to the spike dimensions and the conduction velocity in mammalian A fibres. *American Journal of Physiology* **127**, 393-414.

GELBERMAN, R.H., HERGENROEDER, P.T., HARGENS, A.R., LUNDBORG, G.N. & AKESON, W.H. (1981). The carpal tunnel syndrome. A study of carpal canal pressures. *Journal of Bone and Joint Surgery* **63**, 380-383.

GELBERMAN, R.H., SZABO, R.M., WILLIAMSON, R.V., HARGENS, A.R., YARU, N.C. & MINTEER-CONVERY, M.A. (1983). Tissue pressure threshold for peripheral nerve viability. *Clinical Orthopaedics and Related Research* **178**, 285-291.

GELFAN, S. & TARLOV, I.M. (1956). Physiology of spinal cord, nerve root and peripheral nerve compression. *American Journal of Physiology* **185**, 217-229.

GILBERT, S.G. (1965). Pictorial anatomy of the frog. University of Washington Press.

GILLIATT, R.W. (1980 a). Acute compression block. In *The Physiology of Peripheral Nerve*, Ed A.J. Sumner. W.B. Saunders Company, Philadelphia.

GILLIATT, R.W. (1980 b). Chronic nerve compression and entrapment. *The Physiology of Peripheral Nerve*, Ed A.J. Sumner. 316-339. W.B. Saunders Company, Philadelphia.

GILLIATT, R.W. (1981). Physical injury to peripheral nerves. Physiological and electrodiagnostic aspects. *Mayo Clinics Proceedings* **56**, 361-370.

GILLIATT, R.W. & THOMAS, P.K. (1960). Changes in nerve conduction with ulnar lesions at the elbow. *Journal of Neurology, Neurosurgery, and Psychiatry* **23**, 312-320.

GISSEN, A.J., COVINO, B.G. & GREGUS, J. (1980). Differential sensitivity of mammalian nerve fibres to local anaesthetic agents. *Anaesthesiology* **53**, 467-474.

GISSEN, A.J., COVINO, B.G. GREGUS, J. (1982). Differential sensitivity of fast and slow fibres in mammalian nerve. III. Effect of etidocaine and bupivacaine on fast/slow fibres. *Anaesthesia and Analgesia* **61**, 570-575.

GOTTLIEB, G.L., AGARWAL, G.C. & JAEGER, R.J. (1983). Response to sudden torques about ankle in man: V. Effect of peripheral ischaemia. *Journal of Neurophysiology* **50**, 297-312.

GRAFE, P., REDDY, M.M., EMMERT, H. & BRUGGENCATE, G.T. (1983). Effects of lithium on electrical activity and potassium ion distribution in the vertebrate central nervous system. *Brain Research* **279**, 65-76.

GRISSMER, S. (1986). Properties of potassium and sodium channels in the frog internode. *Journal of Physiology* **381**, 119-134.

GROSSMAN, Y. & GUTNICK, M.J. (1981). Extracellular potassium activity during frequency-dependant conduction block of giant axons in the metathoracic ganglion of the cockroach. *Brain Research* **211**, 196-201.

GRUNDFEST, H. (1936). Effects of hydrostatic pressures upon the excitability, the recovery and the potential sequence of frog nerve. *Cold Spring Harbour Symposia on quantitative biology* **4**, 179-187.

GRUNDFEST, H. & KARTELL, M. (1935). Some effects of hydrostatic pressure on nerve action potential. *American Journal of Physiology* **113**, 56-57.

GUTNICK, M.J., HEINEMANN, U. & LUX, H.D. (1979). Stimulus induced and seizure related changes in extracellular potassium concentration in cat thalamus. *Electroencephalography and Clinical Neurophysiology* **47**, 329-344.

HANSEN, A.K. (1985). Effect of anoxia of ion distribution in the brain. *Physiological Reviews* **65**, 101-148.

HARDY, W.L. (1973 a). Propagation speed in myelinated nerve. I. Experimental dependence on external Na⁺ and on temperature. *Biophysical Journal* **13**, 1054-1070.

HARDY, W.L. (1973 b). Propagation speed in myelinated nerve. II. Theoretical dependence on external Na⁺ and on temperature. *Biophysical Journal* **13**, 1071-1089.

HARGENS, A.R., ROMINE, J.S., SIPE, J.C., EVANS, K.L., MUBARAK, S.J. & AKESON, W.H. (1979). Peripheral nerve conduction block by high muscle-compartment pressure. *Journal of Bone and Joint Surgery* **61**, 192-200.

HARGENS, A.R., SKYHAR, M.J., McCLURE, A.G., O'HARA, R.C., LEIBER, R.L., GERSHUNI, D.H. & AKESON, W.H. (1987). Local compression patterns beneath pneumatic tourniquets applied to arms and thighs of human cadavera. *Journal of Orthopaedic Research* **5**, 247-252.

HARRIMAN, D.G.F. (1977). Ischaemia of peripheral nerve and muscle. *Journal of Clinical Pathology* **11**, 94-104.

HAWKSBEER, F. (1705). Some experiments made of the attraction of bodies in vacuo. *Philosophical Transaction of the Royal Society* **24**, 2165-2175. In Brazier (1984).

HAYASHI, R. BECKER, W.J. WHITE, D.G. & LEE, R.G. (1987). Effects of ischaemic nerve block on the early and late components of the stretch reflex in the human forearm. *Brain Research* **404**, 341-344.

HEINEMANN, U. & LUX, H.D. (1975). Undershoots following stimulus induced rises of extracellular potassium concentration in the cerebral cortex of cat. *Brain Research* **93**, 63-76.

HEINEMANN, U. & LUX, H.D. (1977). Ceiling of stimulus induced rises in extracellular potassium concentration in the cerebral cortex of cat. *Brain Research* **120**, 231-249.

HEINEMANN, U., LUX, H.D. & GUTNICK, M.J. (1977). Extracellular free calcium and potassium during paroxysmal activity in the cerebral cortex of the cat. *Experimental Brain Research* **27**, 237-243.

HERSHEY, W.N. & WAGMAN, I.H. (1966). Effects of ischaemia on range of conduction velocities and on facilitation in human motor nerves. *Transactions of the American Neurological Association* **91**, 246-248.

HESS, K., EAMES, R.A., DARVENIZA, P. & GILLIATT, R.W. (1979). Acute ischaemic neuropathy in the rabbit. *Journal of the Neurological Sciences* **44**, 19-43.

HILLE, B. (1966). Common mode of action of three agents that decrease the transient change in sodium permeability in nerves. *Nature* **210**, 1220-1222.

HILLE, B. (1967). The delayed inhibition of delayed potassium currents in nerve by tetraethylammonium ion. *Journal of General Physiology* **50**, 1287-1302.

HILLE, B. (1992). *Ionic channels of excitable membranes* (2nd edition). Sinauer Associates, Massachusetts.

HODGKIN, A. L. & HUXLEY, A. F. (1939). Action potentials recorded from inside a nerve fibre. *Nature* **140**, 710-711.

HODGKIN, A. L. & HUXLEY, A. F. (1945). Resting and action potentials in single nerve fibres. *Journal of Physiology* **104**, 176-195.

HODGKIN, A.L. & KATZ, B. (1949). The effect of sodium ions on the electrical activity of the giant axon of the squid. *Journal of Physiology* **108**, 37-77.

HODGKIN, A.L. & HOROWICZ, P. (1959). The influence of potassium and chloride ions on the membrane potential of single muscle fibres. *Journal of Physiology* **148**, 127-160.

HODGKIN, A. L. HUXLEY, A. F. & KATZ, B. (1952). Measurement of current voltage relations in the membrane of the giant axon of *Loligo*. *Journal of Physiology* **116**, 424-448.

HODGKIN, A. L. & HUXLEY, A. F. (1952 a). Current carried by sodium and potassium ions through the membrane of the giant axon of *Loligo*. *Journal of Physiology* **116**, 449-472.

HODGKIN, A. L. & HUXLEY, A. F. (1952 b). The components of membrane conductance in the giant axon of *Loligo*. *Journal of Physiology* **116**, 473-496.

HODGKIN, A. L. & HUXLEY, A. F. (1952 c). The dual effects of membrane potential on sodium conductance in the giant axon of *Loligo*. *Journal of Physiology* **116**, 497-506.

HODGKIN, A. L. & HUXLEY, A. F. (1952 d). A quantitative description of membrane current and its application to conduction and excitation in nerve. *Journal of Physiology* **117**, 500-544.

HOPPE, D., CHVATAL, A., KETTENMANN, H., ORKLAND, R.K. & RANSOM, B.R. (1991). Characteristics of activity-dependent potassium accumulation in mammalian peripheral nerve *in vitro*. *Brain Research* **552**, 106-112.

HUMBOLDT, F.A. (1797). Versuche über die gereizte Muskel und Nervenfasser. Rottmann, Posen and Decker, Berlin. In Brazier (1984).

HURSH, J.B. (1939). Conduction velocity and diameter of nerve fibres. *American Journal of Physiology* **127**, 131-139.

HUTCHINSON, N.A., KOLES, Z.J. & SMITH, R.S. (1970). Conduction velocity in myelinated nerve fibres of *Xenopus laevis*. *Journal of Physiology* **208**, 279-289.

HUXLEY, A.F. & STÄMPFLI, R. (1949). Evidence for saltatory conduction in peripheral myelinated nerve fibres. *Journal of Physiology* **108**, 315-339.

HUXLEY, A.F. & STÄMPFLI, R. (1951 a). Direct determination of membrane resting potential and action potential in single myelinated nerve fibres. *Journal of Physiology* **112**, 476-495.

HUXLEY, A.F. & STÄMPFLI, R. (1951 b). Effect of potassium and sodium on resting and action potentials of single myelinated nerve fibres. *Journal of Physiology* **112**, 496-508.

JACK, J.J.B., NOBLE, D. & TSIEN, R.W. (1975). Electric current flow in excitable cells. Clarendon Press, Oxford.

JAEGER, R.J., GOTTLIEB, G.L., AGARWAL, G.C. & TAHMOUSH, A.J. (1982). Afferent contributions to stretch-evoked myoelectric responses. *Journal of Neurophysiology* **48**, 403-418.

KALICHMAN, M.W. & MYERS, R.R. (1991). Transperineurial vessel constriction in an edematous neuropathy. *Journal of Neuropathology and Experimental Neurology* **50**, 408-418.

KATZ, B. (1966). *Nerve, Muscle and Synapse*. McGraw-Hill, New York.

KOCSIS, J.D., MALENKA, R.C. & WAXMAN, S.G. (1983). Effects of extracellular potassium concentration on the excitability of the parallel fibres of the rat cerebellar cortex. *Journal of Physiology* **334**, 225-244.

KOCSIS, J.D., ENG, D.L., GORDON, T.R. & WAXMAN, S.G. (1987). Functional differences between 4-aminopyridine and tetraethylammonium-sensitive potassium channels in myelinated axons. *Neuroscience Letters* **75**, 193-198.

KORTHALS, J.K. & WIŚNIEWSKI, H.M. (1975). Peripheral nerve ischaemia. Part I. Experimental model. *Journal of Neurological Sciences* **24**, 65-76.

KRAIG, R.P. & NICHOLSON, C. (1978) Extracellular ionic variations during spreading depression. *Neuroscience* **3**, 1045-1059.

KRISHNAN, N. & SINGER, M (1973). Penetration of peroxidase into peripheral nerve fibres. *American Journal of Anatomy* **136**, 1-14.

KRÍZ, N., SYKOVÁ, E. & VYKLIČKY, L. (1975). Extracellular potassium changes in the spinal cord of the cat and relation to the slow potentials, active transport and impulse transmission. *Journal of Physiology* **249**, 167-182.

KRNJEVIĆ, K. (1954). The connective tissue of the frog sciatic nerve. *Quarterly Journal of Experimental Physiology* **39**, 55-71.

KRNJEVIĆ, K. & MORRIS, M.E. (1973). Extracellular potassium ion activity and slow potential changes in spinal cord and medulla. *Canadian Journal of Physiology and Pharmacology* **50**, 1214-1217.

LACHANCE, D.H. & DAUBE, J.R. (1991). Acute peripheral arterial occlusion: Electrophysiologic study of 32 cases. *Muscle and Nerve* **14**, 633-639.

LANDON, D. N. (1982). The structure of the nerve fibre. In *Abnormal nerves and muscles as impulse generators*. Ed. Culp, W.J. & Ochoa, J. Oxford University Press, Oxford.

LANDAU, W. & BISHOP, G.H. (1953). Pain from dermal, periosteal and fascial endings and from inflammation. *Archives of Neurology and Psychiatry* **69**, 490-504.

LEHMANN, J.E. (1937). The effects of asphyxia on mammalian A nerve fibres. *American Journal of Physiology* **119**, 111-120.

LEWIS, T., PICKERING, G.W. & ROTHSCHILD, P. (1931). Centripetal paralysis arising out of arrested blood flow to the limb. *Heart* **16**, 1-32.

LUNDBORG, G. (1970). Ischaemic nerve injury. *Scandinavian Journal of Plastic and Reconstructive Surgery, Supplement 6*, 1-112.

LUNDBORG, G. (1975). Structure and function of the intraneural microvessels as related to trauma, edema formation, and nerve function. *Journal of Bone and Joint Surgery* **57A**, 938-948.

LUNDBORG, G. (1988). *Nerve injury and Repair*. Churchill Livingstone, Edinburgh.

LUNDBORG, G. & RYDEVIK, B. (1973). Effects of stretching the tibial nerve of the rabbit. A preliminary study of the intraneural circulation and the barrier function of the perineurium. *Journal of Bone and Joint Surgery* **55**, 390-401.

LUNDBORG, G., GELBERMAN, R.H., MINTEER-CONVERY, M., LEE, Y.F. & HARGENS, A.R. (1982). Median nerve compression in the carpal tunnel-functional response to experimentally induced controlled pressure. *Journal of Hand Surgery* **7**, 252-259.

LUTTGES, M.W. (1973). Studies of parameters relating to spinal disfunction. In *Biomechanics Conference on the Spine*. Ed. Suh, C.H. University of Colorado.

MACKENZIE, R.A., BURKE, D., SKUSE, N.F. & LETHLEAN, A.K. (1975). Fibre function and perception during cutaneous nerve block. *Journal of Neurology, Neurosurgery, and Psychiatry* **38**, 865-873.

MACGREGOR, R.J., SHARPLES, S.K. & LUTTGES, M.W. (1975). A pressure vessel model for nerve compression. *Journal of Neurological Sciences* **24**, 299-304.

MAGLADERY, J.W., McDOUGAL, D.B. & STOLL, J. (1950). Electrophysiological studies of nerve and reflex activity in normal man. II. The effects of peripheral ischaemia. *Bulletin of the Johns Hopkins Hospital* **86**, 291-312.

MAROTTE, L.R. (1974). An electron microscope study of chronic median nerve compression in the guinea-pig. *Acta Neuropathologica* **27**, 69-75.

MATSUMONTO, N. (1983). An experimental study on compression neuropathy-measurement of blood flow with hydrogen wash-out technique. *Journal of Japanese Orthopaedic Association* **57**, 805-816.

MIDDLETON, R.W.D. & VARIAN, J.P. (1974). Tourniquet paralysis. *Australian and New Zealand Journal of Surgery* **44**, 124-128.

MODDEL, G., BEST, B. & ASHBY, P. (1977). Effect of differential nerve block on inhibition of the monosynaptic reflex by vibration in man. *Journal of Neurology, Neurosurgery, and Psychiatry* **40**, 1066-1071.

MOODY, W.J.Jr., FUTAMACHI, K.J. & PRINCE, D.A. (1974). Extracellular potassium activity during epileptogenesis. *Experimental Neurology* **42**, 248-263.

MOORE, M.R., GARTIN, S.R. & HARGENS, A.R. (1987). Wide tourniquets eliminate blood flow at low inflation pressures. *Journal of Hand surgery* **12A**, 1006-1011.

MORRIS, H.H. & PETERS, B.H. (1976). Pronator syndrome: clinical and electrophysiological features of seven cases. *Journal of Neurology, Neurosurgery, and Psychiatry* **39**, 461-464.

MUIRHEAD, A. & NEWMAN, R.J. (1986). A low pressure tourniquet system for the lower limb. *Injury* **17**, 53-54.

MUKHERJEE, D.J. (1977). Tourniquet paralysis. *Journal of the International Medical Association* **69**, 130-132.

MYERS, R.R., MURAKAMI, H. & POWEL, H.C. (1986). Reduced nerve blood flow in edematous neuropathies - a biomechanical mechanism. *Microvascular Research* **32**, 145-151.

NATHAN, P.W. & SEARS, T.A. (1962). Differential nerve block by sodium-free and sodium deficient solutions. *Journal of Physiology* **164**, 375-394.

NOLLET, J.A. (1746). Memoires de l'Academie Royale des Sciences. 1-25. In Brazier (1984).

NUKADA, H. & DYCK, P.J. (1984). Microsphere embolism of nerve capillaries and fibre degeneration. *American Journal of Pathology* **115**, 275-287.

OCHOA, J. (1980). Nerve fibre pathology in acute and chronic compression. In *Management of peripheral nerve problems*. Ed. Omer, G.E. and Spinner, M., W.B. Saunders, Philadelphia.

OCHOA, J., FOWLER, T.L. & GILLIATT, R.W. (1971). Nature of the nerve lesion caused by a pneumatic tourniquet. *Nature* **233**, 265-266.

OCHOA, J., FOWLER, T.L. & GILLIATT, R.W. (1972). Anatomical changes in peripheral nerves compressed by pneumatic tourniquet. *Journal of Anatomy* **113**, 433-455.

OCHOA, J. & MAROTTE, L. (1973). The nature of the nerve lesion caused by chronic entrapment in the guinea-pig. *Journal of the Neurological Sciences* **19**, 491-499.

OGATA, K. & NAITO, M. (1986). Blood flow of peripheral nerve. Effects of dissection, stretching and compression. *Journal of Hand Surgery* **11B**, 10-14.

OKADA, Y. & McDOUGAL, Jr., B.D. (1971). Physiological and biochemical changes in frog sciatic nerve during anoxia and recovery. *Journal of Neurochemistry* **18**, 2335-2353.

OLMARKER, K. (1990). Spinal nerve root compression. Ph.D thesis, University of Göteborg, Sweden.

OLNEY, R.K. and MILLER, R.G. (1983). Pseudo conduction block in normal nerves. *Muscle and Nerve* **6**, 530.

OLNEY, R.K., BUDINGEN, H.J. & MILLER, R.G. (1987). The effect of temporal dispersion on compound action potential area in human peripheral nerve. *Muscle and Nerve* **10**, 728-733.

OLSON, W.H. & BEMENT, S.L. (1981). Compound action potential reconstruction and predicted fibre diameter distributions. *Progress in Clinical and Biological Research* **52**, 57-84.

OSTWALD, W. (1890). Elektrische Eigenschaften halbdurchlässiger Scheidewände. *Z. Phys. Chem.* **6**, 71-82. In Tasaki (1982).

PAINTAL, A.S. (1965). Block of conduction in mammalian myelinated nerve fibres by low temperatures. *Journal of Physiology* **180**, 1-19.

PARRY, G.J. & BROWN, M.J. (1982). Selective fibre vulnerability in acute ischaemic neuropathy. *Annals of Neurology* **11**, 147-154.

PEGANOV, E.M., KHODOROV, B.I. & SHISHKOVA, L.D. (1973). Slow sodium inactivation related to external potassium in membrane of ranvier node - role of external K. *Biulleten Eksperimentalnoi Biologii I Meditsiny* **76**, 15-24.

POWELL, H.C. & MYERS, R.R. (1986). Pathology of experimental nerve compression. *Laboratory Investigations* **55**, 91-100.

RANSOM, B.R., WALZ, W., DAVIES, P.K. & CARLINI, R. Anoxia-induced changes in extracellular K⁺ and pH in mammalian central white matter. Submitted 1991.

RAYMOND, S.A. (1979). Effects of nerve impulses on threshold of frog sciatic nerve fibres. *Journal of Physiology* **290**, 273-303.

RECHTHAND, E. & RAPOPORT, S.I. (1987). Regulation of the microenvironment of peripheral nerve: Role of the blood-nerve barrier. *Progress in Neurobiology* **28**, 303-343.

REDDY, M.M. & BURES, J. (1980). Cortical (K⁺)_o and the stimulation induced blockade of spreading depression in the rat cerebral cortex. *Neuroscience Letters* **17**, 243-247.

REID, K.H., MARRANNES, R. & WAUQUIR, A. (1988). Spreading depression and central nervous system pharmacology. *Journal of Pharmacological Methods* **19**, 1-21.

RITCHIE, J.M. (1967). The oxygen consumption of mammalian non-myelinated nerve fibres at rest and during activity. *Journal of Physiology* **188**, 309-330.

RITCHIE, J.M. (1982). On the relation between fibre diameter and conduction velocity in myelinated nerve fibres. *Proceedings of the Royal Society* **B217**, 29-35.

RITCHIE, J.M. (1985). A note on the mechanism of resistance to anoxia and ischaemia in pathophysiological mammalian myelinated nerve. *Journal of Neurology, Neurosurgery, and Psychiatry* **48**, 274-277.

ROBERTS, J.T. (1948). The effect of occlusive arterial diseases of the extremity on the blood supply of nerves. Experimental and clinical studies on the role of the vasa nervorum. *American Heart Journal* **35**, 369-392.

RÖPER, J. & SCHWARZ, J. (1989). Heterogeneous distribution of fast and slow potassium channels in myelinated rat nerve fibres. *Journal of Physiology* **416**, 93-110.

RUDGE, R., OCHOA, J. & GILLIATT, R.W. (1974). Acute peripheral nerve compression in the baboon. *Journal of the Neurological Sciences* **23**, 403-420.

RUSHTON, W.A.H. (1937). Initiation of the propagated disturbance. *Proceedings of the Royal Society* **B115**, 210.

RUSHTON, W.A.H. (1951). A theory of the effects of fibre size in medullated nerve. *Journal of Physiology* **115**, 101-122.

RYDEVIK, B. & LUNDBORG, G. (1977). Permeability of intraneural microvessels and perineurium following acute, graded experimental nerve compression. *Scandinavian Journal of Plastic and Reconstructive Surgery* **11**, 179-187.

RYDEVIK, B. & NORDBORG, C. (1980). Changes in nerve function and nerve fibre structure induced by acute, graded compression. *Journal of Neurology, Neurosurgery, and Psychiatry* **43**, 1070-1082.

RYDEVIK, B., LUNDBORG, G. & BAGGE, U. (1981). Effects of graded compression on intraneural blood flow. *Journal of Hand Surgery* **6**, 3-12.

RYDEVIK, B., LUNDBORG, G. & SHALAK, R. (1987). Biomechanics of Peripheral nerve. In Frankel, W.H. & Nordin, M. *Basic biomechanics of the skeletal system*. Lea and Febiger, Philadelphia.

RYDMARK, M. & BERTHOLD, C-H. (1983). Electron microscopic serial section analysis of nodes of Ranvier in lumbar spinal roots of the cat: a morphometric study of nodal compartments in fibres of different sizes. *Journal of Neurocytology* **12**, 537-565.

SHANES, A.M. (1951). Factors in nerve functioning. *Federation Proceedings* **10**, 611-621.

SMITH, K.S. & SCHAUF, C.L. (1981). Size-dependant variation of nodal properties in myelinated nerve. *Nature* **293**, 297-299.

SPINNER, M. & SPENCER, P.S. (1974). Nerve compression lesions of the upper extremity. A clinical and experimental review. *Clinical and Orthopaedic Related Research* **104**, 46-67.

STÄMPFLI, R. (1959). Is the resting potential of Ranvier nodes a potassium potentials? *Annals of the New York Academy of Sciences* **81**, 265-284.

STÄMPFLI, R. & HILLE, B. (1976). Electrophysiology of the peripheral myelinated nerve. In *Frog Neurobiology*. Ed. Llinás, R. & Precht, W. Springer-Verlag, New York.

STEGEMAN, D.F. & DE WEERD, J.P.C. (1982 a). Modelling compound action potentials of peripheral nerves *in situ*. I. Model description; Evidence for a non-linear relation between fibre diameter and velocity. *Electroencephalography and Clinical Neurophysiology* **54**, 436-448.

STEGEMAN, D.F. & DE WEERD, J.P.C. (1982 b). Modelling compound action potentials of peripheral nerves *in situ*. II. A study of the influence of temperature. *Electroencephalography and Clinical Neurophysiology* **54**, 516-529.

SUNDERLAND, S. (1976). The nerve lesion in the carpal tunnel syndrome. *Journal of Neurology, Neurosurgery, and Psychiatry* **39**, 615-626.

SUNDERLAND, S. (1978). *Nerve and nerve injury* (2nd Edition). Churchill Livingstone, Edinburgh.

SUNDERLAND, S. & BRADLEY, K.C. (1949). The cross sectional area of nerve trunks devoted to nerve fibres. *Brain* **72**, 428-449.

SYKOVÁ, E., SHIRAYEV, B., KRÍŽ, N. & VYKLICKÝ, L. (1976). Accumulation of extracellular potassium in the spinal cord of the frog. *Brain Research* **106**, 413-417.

SYKOVÁ, E. & ORKLAN, R.K. (1980). Extracellular potassium accumulation and transmission in frog spinal cord. *Neuroscience* **5**, 1421-1428.

SZABO, R., GELBERMAN, R., WILLIAMSON, R. & HARGENS, A. (1983). Effects of increased systemic blood pressure on the tissue fluid pressure. Threshold of peripheral nerve. *Journal of Orthopaedic Research* **1**, 172-178.

TASAKI, I. (1939). The strength-duration relationship of the normal, polarized and narcotized nerve fibre. *American Journal of Physiology* **125**, 367-379.

TASAKI, I. (1955). New measurements of the capacity and the resistance of the myelin sheath and the nodal membrane of the isolated frog nerve fibre. *American Journal of Physiology* **181**, 639-650.

TASAKI, I. (1959). Conduction of the nerve impulse. In *Handbook of Physiology*, section 1. Ed. Field, J. American Physiological Society, Washington D.C.

TASAKI, I. (1968). *Nerve excitation*. Charles, C. Thomas. Springfield, Illinois.

TASAKI, I. (1982). *Physiology and electrochemistry of nerve fibres*. In the series "Biophysics and Bioengineering", Ed. Noordergraak, A. Academic Press, New York.

TASAKI, I. & TAKEUCHI, T. (1941). Der am Ranvierschen Knoten entstehende Aktionsstrom und seine Bedeutung für die Erregungsleitung. *Pflügers Archive* **244**, 696-711.

TASAKI, I. & TAKEUCHI, T. (1942). Weitere Studien über den Aktionsstrom der markhaltigen Nervenfasern und über die elektrolytische Übertragung des Nervenimpulses. *Pflügers Archive* **245**, 764-782.

TASAKI, I. ISHII, K. & ITO, H. (1943). On the relation between the conduction rate, the fibre diameter and the internodal distance of the medullated nerve fibre. *Japanese Journal of Medical Science and Biophysics* **9**, 189-199.

TOREBJÖRK, H.E. & HALLIN, R.G. (1973). Perceptual changes accompanying controlled preferential blocking of A and C fibre responses in intact skin nerves. *Experimental Brain Research* **16**, 321-332.

TROJABORG, W. (1970). Rate of recovery in motor and sensory fibres of the radial nerve: clinical and electrophysiological aspects. *Journal of Neurology, Neurosurgery, and Psychiatry* **33**, 625-638.

UEHARA, Y. (1958). Conduction of nervous impulses in NaCl-deficient media. *Japanese Journal of Physiology* **8**, 282-291.

ULBRICHT, W. (1981). Kinetics of drug action and equilibrium at the node of Ranvier. *Physiological Reviews* **61**, 785-828.

ULBRICHT, W. (1983). Rates of drug action at the node of Ranvier. *Experientia* **39**, 942-946.

VOLTA, A. (1792). Memoria prima sull'elettricità animale. *Giornale fisico-medico* **1**, 146-187. In Brazier (1984).

Von HELMHOLTZ, H. (1850). Über die Fortpflanzungsgeschwindigkeit der Nervenreizung. *Archive of Anatomy, Physiology and Medicine* 71-73. In Brazier (1988).

VYSKOČIL, F., KRÍZ, N. & BUREŠ, J. (1972). Potassium selective microelectrodes used for measuring the extracellular brain potassium during spreading depression and anoxic depolarisation in rats. *Brain Research* **39**, 255-259.

WALZ, W. & HERTZ, L. (1983). Functional interactions between neurones and astrocytes. II. Potassium homeostasis as the cellular level. *Progress in Neurobiology* **20**, 133-183.

WIECHERS, D. & FATEHI, M. (1983). Change in the evoked potential area of normal median nerves with computer techniques. *Muscle and Nerve* **6**, 532.

WEISS, P. & HISCOE, H.H. (1948). Experiments on the mechanism of nerve growth. *Journal of Experimental Zoology* **107**, 315-393.

WRIGHT, E.B. (1946). A comparative study of the effects of oxygen lack on peripheral nerve. *American Journal of Physiology* **147**, 78-89.

YATES, S.K., HURST, L.N. & BROWN, W.F. (1981). The pathogenesis of pneumatic tourniquet paralysis in man. *Journal of Neurology, Neurosurgery, and Psychiatry* **44**, 759-767.

YARNITSKY, D. & OCHOA, J.L. (1989). Sensations conducted by large and small myelinated afferent fibres are lost simultaneously under compression-ischaemia block. *Acta Physiologica Scandinavica* **137**, 319.

YOUNG, J. Z. (1936). The giant nerve fibres and epistellar body of cephalopods. *Quarterly Journal of Microscopic Science* **78**, 367-386.

YOUNG, W., KOREH, I., YEN, V. & LINDSAY, A. (1982). Effect of sympathectomy on extracellular potassium activity and blood flow in experimental spinal cord contusion. *Brain Research* **253**, 115-125.

YOUNG, W. & KOREH, I. (1986). Potassium and calcium changes in injured spinal cords. *Brain Research* **365**, 42-53.

Conduction slowing and conduction block induced by high extracellular calcium concentration in isolated myelinated nerve fibres of the frog, *Rana temporaria*

BY R. FERN and P. J. HARRISON. *Department of Physiology, University College London, Gower St, London WC1E 6BT*

Increasing extracellular calcium concentration shifts the voltage dependence of the ionic conductances in the hyperpolarizing direction (Hille, 1968; Brismar & Frankenhaeuser, 1972). Such a shift is expected to result in conduction velocity slowing and/or conduction failure. The aim of the present investigation is to examine this possibility for calcium solutions of higher concentration than in normal plasma.

The sciatic nerve was dissected, desheathed and placed in a bath that allowed external perfusion of the middle portion of the nerve. Peripheral branches of the nerve were stimulated electrically and single-unit responses were recorded from teased filaments of the central end. Typically, the middle portion of the nerve was perfused with Ringer's solution containing 32 mM-calcium, and action-potential conduction time was continuously monitored. Velocities of axonal conduction over the perfused length of nerve were calculated.

Conduction velocities fell in an exponential manner. Semilogarithmic plots revealed that the time constant of conduction velocity slowing was similar for different fibres (range 25–130 min), and independent of initial conduction velocity (and hence presumably of axon diameter). The long time constant is presumably due to the presence of diffusion barriers in the nerve trunk, even though the nerve had been desheathed. Conduction velocity slowing was often followed by conduction failure. However, the tendency to fail was also unrelated to initial conduction velocity (and hence also to axon diameter).

These actions of high calcium are similar to those found in nerve-cooling experiments (Paintal, 1965; Franz & Iggo, 1968). Thus, for both high calcium and cooling there is no obvious correlation between initial conduction velocity and either conduction slowing or time to block. This contrasts with the action of anaesthetic solutions which appear to exert a differential action on fibres of different diameter (Franz & Perry, 1974).

REFERENCES

- BRISMAR, T. & FRANKENHAEUSER, B. (1972). *Acta physiol. scand.* **85**, 237–241.
FRANZ, D. N. & IGGO, A. (1968). *J. Physiol.* **199**, 319–345.
FRANZ, D. N. & PERRY, R. S. (1974). *J. Physiol.* **236**, 193–210.
HILLE, B. (1968). *J. gen. Physiol.* **51**, 221–236.
PAINTAL, A. S. (1965). *J. Physiol.* **180**, 1–19.

The sequence of pressure-induced conduction failure of myelinated fibres in the isolated sciatic frog nerve (*Rana temporaria*) is dependent upon the pressure applied

By ROBERT FERN and P. J. HARRISON. *Department of Physiology, University College London, Gower Street, London WC1E 6BT*

The original work of Gasser & Erlanger (1929) described the susceptibility of fibres of different diameters to nerve compression. They monitored the compound action potential of amphibian nerve subjected to pressure and reported that the fast components of the potential were depressed before the slower components. On the basis of this, they concluded that larger-diameter axons are more susceptible to nerve compression than smaller axons. However, assessments of conduction block on the basis of compound action potentials can be misleading, since conduction slowing often precedes conduction failure. We have therefore repeated the work of Gasser & Erlanger using both compound action potentials and, more importantly, single-unit recordings.

The sciatic nerve was dissected and mounted in a paraffin bath. The bath incorporated a device designed to allow pressure to be applied to a 24 mm length of the nerve, pneumatically, through a compliant rubber sleeve. For single unit recording, central branches of the nerve were stimulated electrically and between five and twelve single unit responses could be distinguished from fine peripheral nerve branches. The rubber sleeve was then inflated to 250 mmHg and the behaviour of single-unit action-potential conduction was monitored.

In five such experiments, sequential failure of single units was characterized by the fastest units failing first. In other experiments recording the compound action potential, the earliest component of the potential was depressed first. These results are in accordance with those of Gasser and Erlanger.

However, during a further series of single-unit experiments in which the nerve was subjected to greater pressure (around 800 mmHg) the order of block was reversed. In these experiments the sequential block started with the slowest units. Similar results were also obtained with recordings of compound action potentials. This reversal in the order of block is surprising and suggests that small myelinated axons are more susceptible to large pressures.

Amphibian nerve can maintain viability for several hours without an oxygen supply. Our findings therefore reveal the actions of compression alone upon axons. Whether similar results would be found in mammalian nerve, with concomitant anoxia, has yet to be examined.

REFERENCE

GASSER, H. S. & ERLANGER, J. (1929). *Am. J. Physiol.* **88**, 581-591.

The contribution of ischaemia and axon deformation to conduction block induced by compression in the sciatic nerve of the anaesthetized cat

BY ROBERT FERN and P. J. HARRISON. *Department of Physiology, University College London, Gower Street, London WC1E 6BT*

It is uncertain whether compression-induced conduction failure in mammalian nerve results from the direct mechanical deformation of nerve fibres or from nerve ischaemia following obstruction of the blood supply. We have recently performed two series of experiments that now allow us to examine this matter. In the first series, we investigated the effect of direct mechanical deformation of nerve fibres using the isolated frog sciatic nerve, a preparation which remains viable for long periods despite the absence of a blood supply. Results revealed that modest compression leads to conduction block initially in the fast-conducting, large-diameter, myelinated axons (Fern & Harrison, 1989). In the second series, we demonstrated that ischaemic conduction block in cat nerve is associated with a more rapid conduction failure of the smaller myelinated axons (Fern & Harrison, 1990). We have now used these contrasting actions to evaluate the importance of ischaemia and deformation in compression-induced conduction failure in a mammalian preparation *in vivo*.

Experiments were performed on cats anaesthetized with chloralose (70 mg/kg, i.v., supplemented as required), paralysed and artificially respired. Blood pressure was maintained above 110 mmHg. The sciatic nerve was exposed and an arrangement involving a rubber balloon was used such that inflation of the balloon exerted pressure evenly upon the nerve trunk. The balloon was inflated to either 70 or 250 mmHg pressure. Single unitary potentials were recorded from spinal root filaments following electrical stimulation of hindlimb peripheral nerves. Conduction in single axons was thus monitored during sciatic nerve compression.

When the pressure in the balloon was 70 mmHg, a plot of the initial conduction velocity against survival time following the onset of compression, revealed that the slower-conducting myelinated axons tend to fail before faster-conducting axons ($n = 62$; correlation coefficient $r = 0.7$, $P < 0.001$). In contrast, with a higher degree of compression (balloon pressure 250 mmHg), the faster-conducting axons tended to fail first ($n = 226$; correlation coefficient $r = -0.226$, $P < 0.001$).

That mild compression and ischaemia have similar effects indicates that ischaemia plays an important role in those nerve-compression disorders with an insidious onset and chronic time course. On the other hand, the similarity of severe compression and deformation indicates that deformation is of major importance in nerve-compression disorders with a sudden onset and acute time course. This is of interest clinically, in relation to the chronic and acute forms of compression disorders that have long been recognized.

Supported by the MRC.

REFERENCES

- FERN, R. & HARRISON, P. J. (1989). *J. Physiol.* **418**, 77P.
FERN, R. & HARRISON, P. J. (1990). *Neurosci. Lett. Suppl.* **38**, S 33.

The slow time course of conduction slowing in myelinated axons of the isolated frog sciatic nerve perfused with a high concentration of potassium ions

By ROBERT FERN and P. J. HARRISON. *Department of Physiology, University College London, Gower Street, London WC1E 6BT*

Perfusion of isolated nerve fibres with a high concentration of potassium ions produces a depolarization with a very rapid time course (Ulbright, 1983). This corresponds to the rapid diffusion of ions into the node of Ranvier. Little is known, however, about any possible longer-term actions of raised concentrations of potassium ions.

Frog sciatic nerves were dissected and desheathed. Up to three peripheral branches were separated using fine instruments under dissecting optics. Approximately 80–90% of the nerve fibres within a given branch were then carefully removed for a 2 cm length below the major bifurcation at the knee. This produced a preparation, with few diffusion barriers, in which action potential conduction could be monitored for several hours in intact myelinated axons. The nerves were mounted in a recording bath with a central chamber in which the thinned-out length of the nerve was isolated from external paraffin pools. The central chamber was then perfused with either control or test solutions, and unitary action potential responses were recorded from the peripheral end of nerve branches following electrical stimulation of the central end.

Following perfusion with Ringer's solution containing 12 mM potassium, conduction velocity of unitary potentials fell over a long time course, in excess of 80 min if action potential conduction did not fail. When plotted semi-logarithmically the time course of this conduction slowing was often found to have two components, one rapid and one slow. In comparison, perfusion with Ringer's solution containing reduced sodium ion (28 mM) or raised calcium ion (8 mM) concentration produced an approximately stepwise change in conduction velocity.

It has been speculated that the internodal axolemma of nerve fibres has a membrane potential which has significant effects upon the node of Ranvier (Chui & Ritchie, 1984). The compartment which surrounds the internodal axolemma, the periaxonal space, is probably in continuity with the node (Barrett & Barrett, 1982). Thus, perfusion with raised potassium solutions may initially and rapidly depolarize the nodal axolemma, followed by a slower depolarization of the internodal axolemma as ions diffuse into the periaxonal space. This is consistent with all our results, as neither low sodium nor high calcium solutions will produce a similar depolarization and thus can have no corresponding slow element in the time course of their effect.

REFERENCES

- BARRETT, E. F. & BARRETT, J. N. (1982). *J. Physiol.* **323**, 117–144.
 CHUI, S. Y. & RITCHIE, J. M. (1984). *Proc. R. Soc. Lond. B* **220**, 415–422.
 ULBRIGHT, W. (1983). *Experientia* **39**, 942–946.

THE EFFECTS OF COMPRESSION UPON CONDUCTION IN MYELINATED AXONS OF THE ISOLATED FROG SCIATIC NERVE

BY ROBERT FERN AND P. J. HARRISON

From the Department of Physiology, University College London, Gower Street, London WC1E 6BT

(Received 5 January 1990)

SUMMARY

1. Action potential conduction along frog sciatic nerve fibres has been monitored during compression of a mid-portion of the nerve.

2. The effects of compressing a 24 mm length of nerve with a pressure of 250 mmHg applied pneumatically were investigated by recording unitary action potentials. A plot of time before conduction failure (survival time) against initial conduction velocity revealed that the faster myelinated axons tend to fail before the slower myelinated axons. A large degree of scatter was evident in the pooled data as well as in the data from individual experiments.

3. When the compression was made more severe by increasing the applied pressure to 750 mmHg, the order of block was reversed, i.e. the slower myelinated axons tended to block first. Similar scatter in the order of conduction block was observed.

4. The average survival time of units following application of compression was considerably different between these two series of experiments. When 750 mmHg pressure was applied, units survived for, on average, 10.9 min ($n = 246$). When 250 mmHg pressure was applied units survived for, on average, 50.4 min ($n = 148$).

5. The results are discussed in relation to the underlying causes of conduction failure as a result of compression and in relation to results from previous investigations.

INTRODUCTION

When a nerve is compressed to a significant degree it loses its ability to conduct action potentials. The mechanisms underlying this conduction failure are not fully understood. Experiments using *in vivo* techniques have highlighted two important factors, namely: (i) the direct mechanical deformation of nerve fibres and (ii) the effects of ischaemia following occlusion of the nerve's blood supply (Bentley & Schlapp, 1943; Ochoa, Fowler & Gilliatt, 1972; Lundborg, Gelberman, Minter-Convery, Lee & Hargens, 1982; Powell & Myers, 1986). However, these studies have been unable to investigate these two aetiological factors separately and a coherent account of the cause of conduction block has thus not been forthcoming.

One of the earliest approaches adopted to study the effect of compression on nerve conduction was introduced by Gasser & Erlanger (1929). These workers subjected the isolated toad sciatic nerve to compression and recorded the compound action

potential. As conduction block developed, the fastest component of the compound action potential was reduced before slower components. Gasser and Erlanger concluded that compression produces a size-dependent order of conduction block, with the fast, large diameter myelinated axons failing before the slower, smaller diameter myelinated axons.

Gasser and Erlanger's approach to the study of compression block is potentially very useful since it allows basic information to be obtained about nerve conduction during the course of compression in a reduced preparation. Furthermore, since the isolated amphibian sciatic nerve is known to be highly resistant to the effects of anoxia (i.e. whole frog nerves can survive for several hours in a completely anoxic environment, Wright, 1946; Okada & McDougal, 1971), the results obtained by Gasser and Erlanger are likely to be entirely due to the result of mechanical deformation of the nerve. Thus, this preparation allows nerve compression to be studied without the involvement of ischaemia or anoxia. However, despite the passage of over 60 years, and despite the importance of Gasser and Erlanger's results to understanding the aetiology of nerve compression block, their results have neither been confirmed nor extended. In the present study we have therefore reinvestigated and extended the results of Gasser and Erlanger using unitary potential recording techniques. In particular we have compared the effects of high and low degrees of compression, an approach which has produced contrasting results. An abstract of this work has been published (Fern & Harrison, 1989).

METHODS

Rana temporaria were stunned, decapitated and pithed. The sciatic nerves were dissected and bathed in Ringer solution of the following composition (mM): NaCl, 110; KCl, 5; CaCl₂, 2; HEPES buffer, 5; pH 7.4, and bubbled with 100% O₂. Care was taken to ensure that the nerve was kept moist at all times. Gross connective tissue was removed though the nerves were not extensively desheathed. Nerves were transferred to a recording bath designed to allow compression of a mid-portion of their length. The bath contained a central chamber consisting of a compliant rubber sleeve through which the nerve was threaded and which was encased within a Perspex tube. The rubber sleeve was everted over the ends of the tube and held in place by secured rubber washers. The space between the Perspex tube and the rubber sleeve was connected to a pressure bottle and manometer via a side arm. This allowed the rubber sleeve to be inflated pneumatically, thereby compressing the nerve. The bath was filled with liquid paraffin which covered the nerve. Experiments were performed at room temperature. The experimental arrangement is shown in Fig. 1.

The central end of the nerve was mounted on a pair of bipolar silver wire electrodes and stimulated electrically using square-wave voltage pulses of 0.1 ms in duration at a rate of 1 s⁻¹. Multiunit action potential recordings were made from fine peripheral nerve branches using bipolar silver wire electrodes. Recordings were pre-amplified either 100 or 1000 times over a band width of 2 Hz to 20 Hz (using an Isleworth preamplifier Type A101) and further amplified as required using an oscilloscope. The stimulus voltage was adjusted such that a number of unitary responses were evoked in individual peripheral nerve branches. The nerve was rested between periods of stimulation which did not last in excess of 20 s and occurred approximately once every 2-5 min.

Stimulation typically evoked a number of potentials in different nerve branches. The recordings were therefore multiunit recordings from which single units could be distinguished. Nerve branches containing many action potentials were often discarded since it was often difficult to distinguish individual potentials as unitary. On the other hand, nerve branches containing only one or two unitary potentials made data collection laborious. The optimal situation was when eight or nine action potentials were present, in which case most of them were distinguishable. The unitary nature of individual potentials was assessed by observing the all-or-nothing manner in which they were

recruited as the stimulus voltage was gradually altered. It was often the case that although the slower conducting unitary potentials were well separated, the faster units tended to occur at similar conduction latencies. However, the dispersion of units that preceded conduction failure, and the all-or-none manner in which individual units blocked, allowed the failure of the majority of unitary potentials to be accurately assessed.

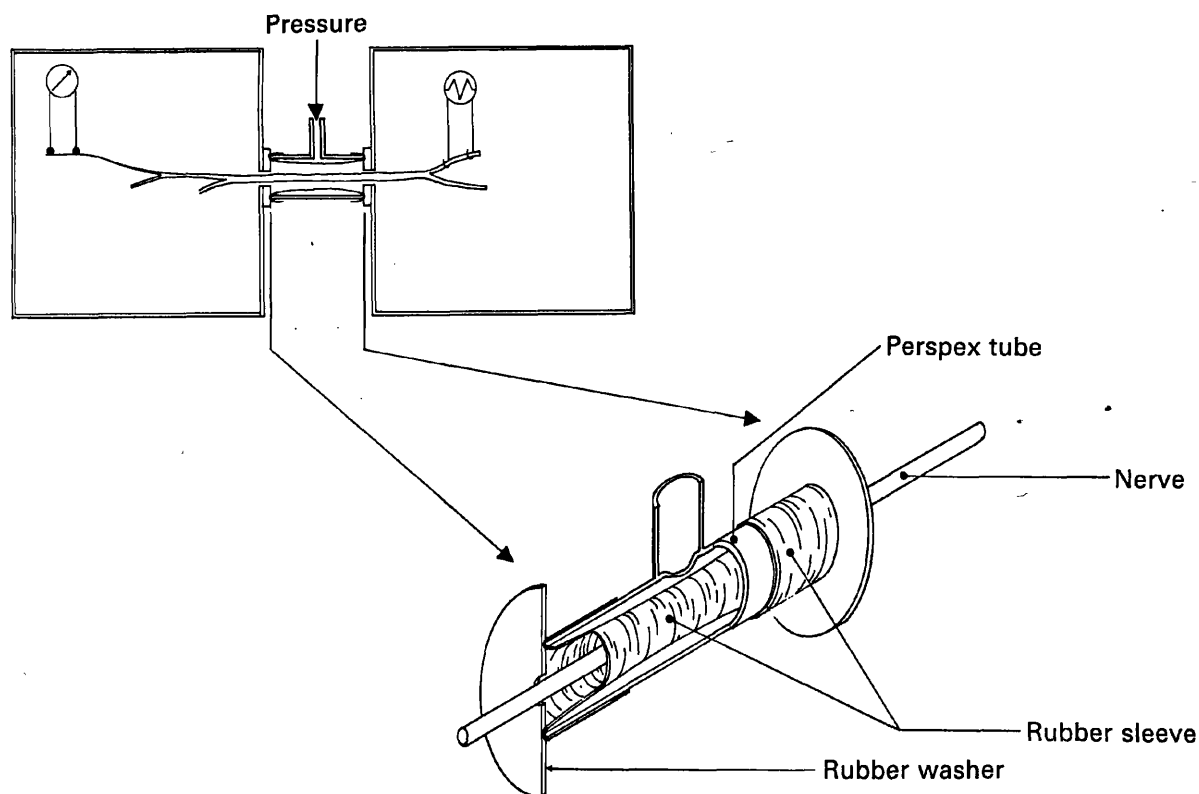

Fig. 1. The experimental arrangement. The nerve was mounted in a paraffin bath incorporating an enclosed central chamber through which the nerve was threaded. The central chamber consisted of an inflatable rubber sleeve passing through and everted over the ends of a Perspex tube. The interior of the tube was connected to a pressure bottle via a side arm. Raising the pressure in the pressure bottle inflated the sleeve, compressing the nerve within. The ends of the perspex tube were secured between two rubber washers to prevent the rubber sleeve becoming dislodged.

A pressure of either 750, 250 or 20 mmHg was applied in the compression chamber to a 24 mm length of nerve. Units with a conduction velocity of greater than 3 m s^{-1} were considered to be myelinated. No data were collected from fibres conducting below 3 m s^{-1} .

RESULTS

Recordings made during compression of 250 mmHg

Figure 2 shows a series of recordings taken during an experiment in which the nerve was subjected to 250 mmHg compression. Prior to, and at the onset of compression (time zero), a number of unitary potentials can be seen to follow the stimulus artifact. The slower conducting units are distinct and can be clearly made out while the faster units tend to arrive together in a cluster. Although it is initially difficult to determine how many units are contained within this cluster, the

dispersion of units which occurs during compression and the all-or-nothing manner in which individual units fail, allows the survival time of the majority of the units to be determined.

Thus, over the first 35 min of compression the records remain similar, although some conduction slowing is evident. At 35 min, however, the amplitude of the

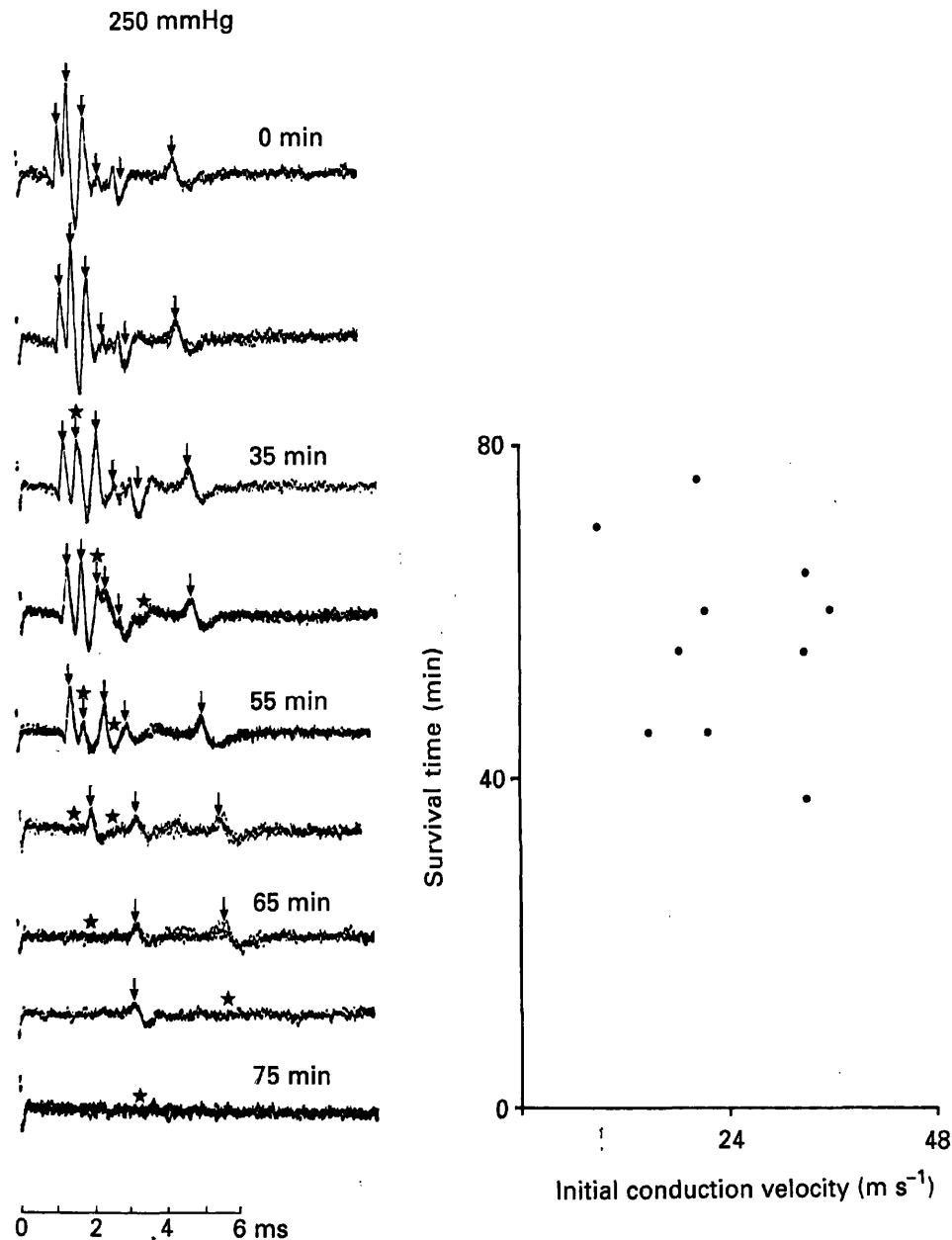

Fig. 2. On the left is a series of records taken during compression by 250 mmHg applied over a 24 mm length of nerve. Unitary potentials are marked with arrows and stars are used to indicate the failure of a unit. The latency of unitary potentials increases with duration of compression and individual units can be seen to fail at various points in time. On the right is a plot of the survival time of units following the onset of compression against initial conduction velocity.

largest spike suddenly falls to half its initial height. This is the consequence of one unit failing at this point revealing a second unit of similar conduction velocity. A star has been used to mark the conduction failure of this unit, and of subsequent units.

In the next record, the third fastest spike and the second slowest spike (which has a large negative component) also fail. Over the following minutes, the remaining unitary potentials can be seen to block until after 75 min no units are left.

On the right of the Fig. 2, the survival times of units following the onset of compression have been plotted against their initial conduction velocity. This reveals

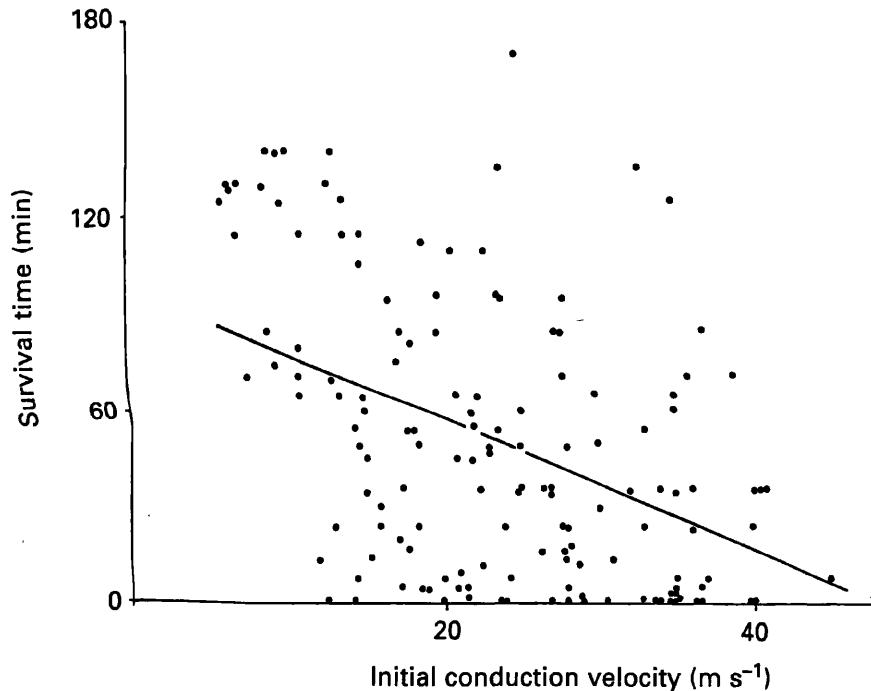

Fig. 3. Plot of the survival time against initial conduction velocity of 148 units (from eight nerves) following application of 250 mmHg compression. A linear regression line has been fitted ($r = -0.44$, $P < 0.001$). The plot reveals that the fast conducting fibres tend to block first under these conditions.

that the data is scattered and that no underlying pattern of conduction block is distinguishable (correlation coefficient $r = 0.30$; $P = 0.47$). This degree of scatter was typical in individual experiments and suggests that factors other than diameter are important in determining the susceptibility of axons to compression.

In order to reduce the effects of scatter, data from a number of experiments have been pooled in Fig. 3 (148 units from eight nerves). An underlying order of conduction failure is now clear, with the faster units tending to fail before the slower. A best fit line (method of least-squares error) has been fitted to the data (correlation coefficient $r = -0.44$; $P < 0.001$). The average survival time for the units is 50.4 min with an average conduction velocity of 23.4 m s⁻¹.

The degree of scatter observed in this size-dependent order of conduction block is of interest in relation to the compound action potential studies of Gasser & Erlanger (1929). Their studies appeared to reveal a smooth transition of conduction block, with the fast axons failing first followed by the slower axons. However, since the compound action potential is the summation of action potentials in a large number of axons, it can only be expected to give a general picture of the conduction block produced by compression. The present single unit experiments allow the conduction

block of individual axons to be assessed more directly and reveal that compression-induced conduction block is far from a smooth succession of fast axons failing before slow axons.

Recordings made during compression at 750 mmHg

In a second series of experiments, a higher degree of compression was applied. Figure 4 shows a series of recordings taken from a nerve compressed by 750 mmHg

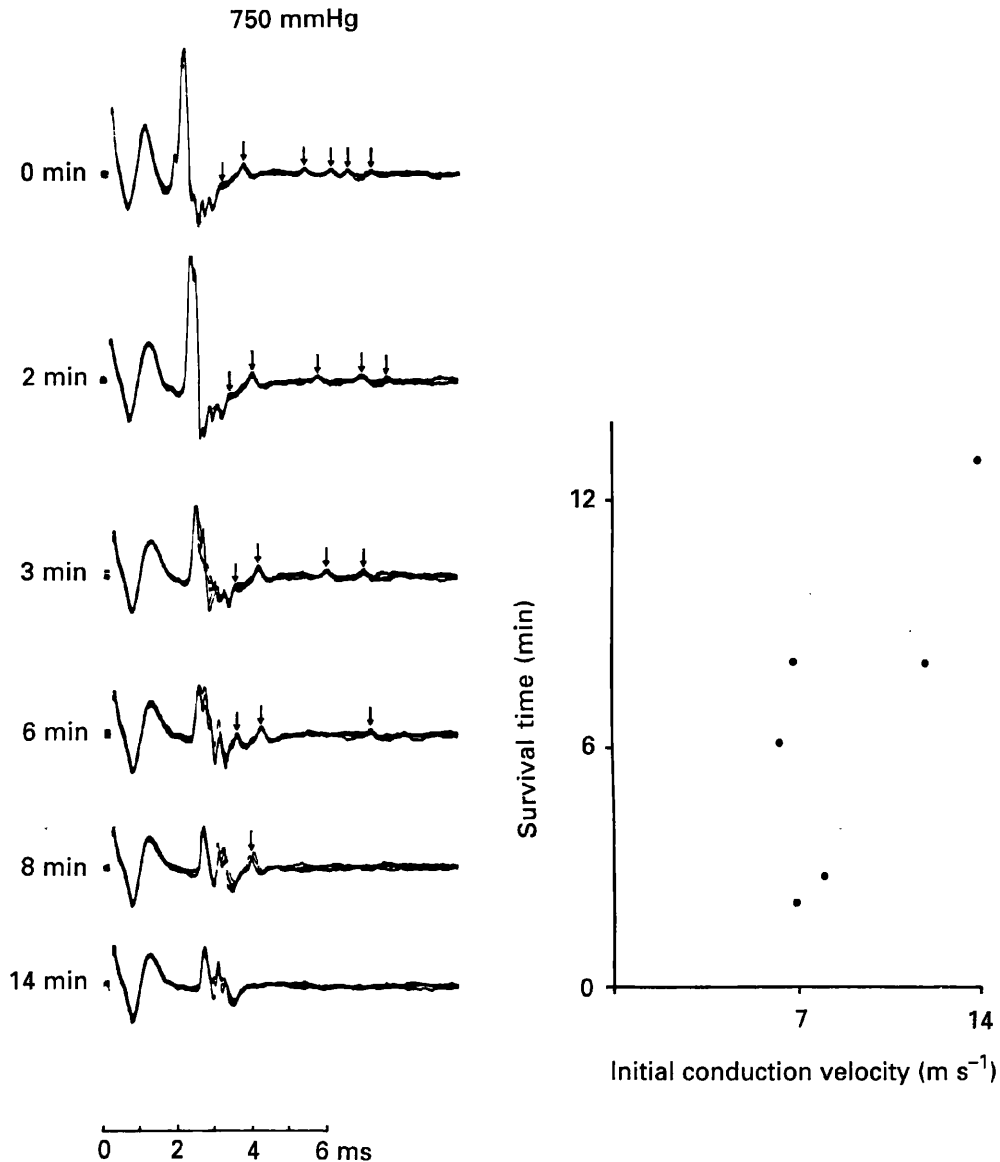

Fig. 4. On the left is a series of records taken during compression by 750 mmHg applied over a 24 mm length of nerve. Unitary potentials are indicated with arrows. The latency of units increases with duration of compression and individual units can be seen to fail to conduct at various points in time. On the right is a plot of survival time of units following the onset of compression against initial conduction velocity.

pressure. Fourteen minutes following the onset of compression many of the units recorded exhibited conduction failure. The failure of individual units was monitored as in Fig. 2, although in this case the cluster of fast conducting units is difficult to

interpret and only the six slower units could be documented. On the right of Fig. 4, the survival times of these units have been plotted against their initial conduction velocity. As was found in the lower compression experiments, scatter in the data from individual experiments did not allow any underlying pattern of conduction

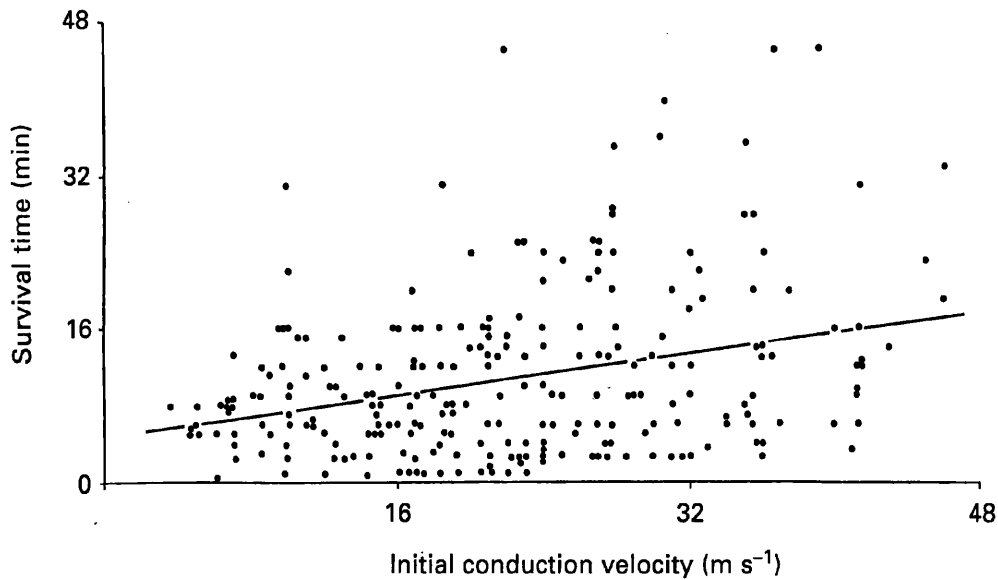

Fig. 5. Plot of the survival time against initial conduction velocity of 246 units (from seventeen nerves) following application of 750 mmHg compression. A linear regression line has been fitted ($r = 0.30$, $P < 0.001$). An order of block is apparent with the slower conducting units tending to fail first.

block to be distinguished (e.g. data of Fig. 4 has a correlation of correlation coefficient of $r = 0.76$; $P = 0.08$).

In Fig. 5, the survival time of 246 units from seventeen such experiments has been plotted against initial conduction velocity. As with compression of 250 mmHg, a great deal of scatter is evident but an underlying relationship, in this case with the slowest units blocking first, is apparent. The best fit line (method of least-squares error) and the probability of correlation ($r = 0.3$; $P < 0.001$) confirm this. The average time to block of these units is 10.9 min, with an average conduction velocity of 22.2 m s^{-1} . The average survival time at the two degrees of compression was significantly different (t test, $P < 0.001$). Thus, as expected, the time to block was much longer when a low degree of compression was applied.

Anoxia over the compressed length of nerve

The frog sciatic nerve is known to be highly resistant to the effect of anoxia (Wright, 1946; Okada & McDougal, 1971). Nevertheless, it is conceivable that in the present study, during compression, the central portion of nerve may become anoxic due to the restricted diffusion of oxygen from the paraffin bath, and that the ensuing anoxia results in conduction failure. However, if this were the case the main effect of restricted diffusion of oxygen should occur at the point when the thin walled rubber sleeve just collapses around the nerve. Thus, experiments were performed in which the pressure was increased to a point just sufficient to collapse the rubber sleeve. In order to achieve this, a pressure of 20 mmHg was used. Of fifty-seven

unitary potentials recorded under such conditions, only five units (9% of the total) had blocked after 220 min. The failure of this small number of axons can adequately be accounted for by the small degree of mechanical deformation that would have resulted from this degree of applied pressure, thereby arguing against a significant contribution of anoxia to conduction failure in these experiments.

DISCUSSION

We have presented evidence that the size-dependent order of compression-induced conduction block is dependent upon the degree of compression applied. When the nerve is compressed by 250 mmHg the order of conduction failure concurs with that deduced by Gasser & Erlanger (1929), with the faster conducting axons tending to block first. However, when the pressure applied is 750 mmHg, the order of conduction failure is reversed and the slower conducting myelinated axons tend to block first.

Underlying causes of conduction block

The study of nerve compression, and the clinical disorders which involve nerve compression, have in the past been complicated by the involvement of both nerve deformation and nerve ischaemia. Thus, *in vivo* studies have characterized the conduction block and the structural changes which follow the application of compression, but have been unable to investigate these two aetiological factors separately. The present investigation is an attempt to investigate the effects of the mechanical component of compression upon nerve conduction. In interpreting the results, we are therefore relying on the assumption that the effects we have observed are in fact due to the mechanical action of compression and unrelated to any concomitant anoxia. However, from the following considerations we believe that anoxia is playing, at most, a minor role.

In these experiments, the frog sciatic nerve is isolated and therefore has no blood supply. Any oxygen supply necessary for conduction, over the time course of these experiments, must gain access to the nerve by diffusion from the paraffin bath. When compression is applied, it is conceivable that diffusion of oxygen from the paraffin bath to the nerve is restricted and that any anoxia induced contributes to the conduction block. However, this would appear unlikely since the frog sciatic nerve is known to be highly resistant to the effects of anoxia and can survive for several hours in a completely anoxic environment (Wright, 1946; Okada & McDougal, 1971). Moreover, in the present study, when such diffusion was restricted by collapsing the thin walled rubber sleeve around the nerve using minimal pressure, only a small proportion of axons fail within 220 min. The failure of these axons can be adequately accounted for by the small degree of mechanical deformation resulting from the degree of pressure applied. Had anoxia played an important part then its contribution should have been evident most clearly when the diffusion path was restricted by collapsing the rubber tube. Increasing the pressure above that required to collapse the rubber tube (20 mmHg) would have little further effect on restricting diffusion, though obviously had dramatic effects on producing conduction failure. These considerations thus fully support the view that anoxia is not a significant

factor in the conduction block produced by compression in these experiments. Thus, the conduction block produced is almost entirely due to the result of mechanical deformation of the nerve and the discussion that follows is based upon this premise.

Mechanical mechanisms of conduction block at different degrees of compression

When a segment of nerve trunk is compressed, the axons will be subject to a pressure gradient which will develop between the compressed and non-compressed regions of the nerve. This pressure gradient results in the displacement of certain axonal material along the axon. Histologically, the damage produced by nerve compression has been characterized by Ochoa *et al.* (1972). These workers applied compression to the medial popliteal nerve of the baboon and observed that the damage that had occurred was selective towards the large fibres. Furthermore, the damage was restricted to the edges of the compressed region and was characterized by the displacement of nodes of Ranvier. This pattern was most easily explained by the actions of the pressure gradient at the edges of the compressed regions. From the duration of compression required (the tourniquets were applied for between 1 and 3 h), and the predilection of damage to large fibres, it seems reasonable to relate this type of damage to that underlying block by low compression in our experiments.

In addition to these changes, the axons are likely to undergo constriction in the region of compression and this is likely to have effects additional to those described by Ochoa *et al.* (1972). These may be negligible when the degree of compression is low, only becoming manifest as compression becomes more severe. In our high compression experiments, the slower axons tend to fail before the faster conducting axons. This must reflect greater trauma to the small axons under these conditions. The conduction block associated with the pressure gradients involves the gradual movement of viscous material along the axon. Increasing the pressure might well speed the rate of displacement, but will also constrict the nerve to a greater extent. We suggest that under severe compression, constriction produces rapid conduction block which preferentially affects the smaller axons.

The work of Edwards & Cattell (1928) supports the involvement of constriction during compression. These workers applied compression to amphibian sciatic nerve using pressures that blocked conduction in under 11 min (i.e. a rate of block comparable to our high compression experiments). They consistently found that compression of an 8 mm length of nerve produced a more rapid block than that of a 4 mm length. They deduced from this that block was predominantly due to constriction of the axons along the compressed region, affecting nerve compressed over a longer length to a greater extent.

Burke, Burne & Martin (1985) and Burke, Cottee, Garvey, Kumarasinghe & Kyriacou (1986) have described a differential block of large optic nerve axons resulting from the application of a high degree of compression over a very short length of nerve (1.5 mm). Over such a distance the nerve will still experience pressure gradients between the compressed and the non-compressed regions, though there will be only a very short length of nerve constricted. In this situation the largest axons were selectively damaged despite the high degree of compression applied. This indicates that a high degree of compression can only differentially affect small axons when there is a significant length of nerve being constricted.

Considering possible mechanisms that might account for the differential action of constriction upon smaller axons, one attractive possibility relates to the shorter length constant of small axons. A short length constant makes an axon more vulnerable to conduction block since the integrity of the axon needs to be compromised for a shorter distance before conduction fails. Thus, constriction, of a magnitude sufficient to suppress active conduction, will have a more profound influence on small axons.

That compression can block small axons differentially appears to contradict the results of Weiss & Hiscoe (1948) and of Luttges (1973). These authors showed that when model nerves, constructed from bundles of rubber tubes of varying diameters, are compressed, deformation is most prominent amongst the larger tubes. Moreover, on theoretical grounds, MacGregor, Sharples & Luttges (1975) have also concluded that the large fibres are most susceptible to compression. However, these models are dependent upon the displacement of intra-axonal material from the region of compression. Considering that axonal constituents are highly viscous, these models are inappropriate for situations where changes occur over a time course that does not allow flow of these materials.

Scatter in the order of conduction block

A consistent finding in these experiments was the large degree of scatter in the size-dependent order of conduction block during compression. There might be many factors contributing to the susceptibility of individual axons to compression, in addition to any size related factors. Amongst these, perhaps the most significant is the location of individual axons within the nerve trunk. Axons located deep within the trunk will be cushioned from compression by both connective tissue and those axons located more superficially. Evidence that the deeper axons are protected from compression in this manner comes from mechanical models (Weiss & Hiscoe, 1948; Luttges, 1973), and *in vivo* studies (Aguayo, Nair & Midgley, 1971; Spinner & Spencer, 1974; Powell & Myers, 1986). Thus, axons can be expected to have a survival time dependent upon their depth within the nerve trunk. Another factor contributing to this variation might be related to the differences in morphology between axons of similar diameter (Sunderland, 1978). Thus, even if all axons were compressed uniformly a strictly size-dependent order of block seems unlikely.

Comparison with previous findings

The results we have obtained allow deformation-induced conduction block to be divided into two distinct classes. Under low compression large axons are blocked first and axons take some time to block. Under higher compression the slower axons block first and over a more rapid time course. In light of these two categories it is useful to re-examine previous findings.

Denny-Brown & Brenner (1944) found that when compression was applied via a mercury filled bag to cat sciatic nerve *in vivo*, 760 mmHg of pressure caused conduction block within 120 s. Following release, recovery was complete within 6 min. Causey & Palmer (1949) applied 200–400 mm of direct mercury pressure over 10 mm to the rabbit gastrocnemius nerve *in vivo* and saw a conduction block with an

average time of 20 min. Rapid recovery was found, the average time taken being 17 s. These two reports, with a short time to block and rapid recovery, are consistent with the high compression block described in our preparation.

In contrast, the following studies describe conduction block consistent with the low compression block of our preparation. Bentley & Schlapp (1943) applied 130–200 mmHg over a 20–40 mm length of cat sciatic nerve and observed conduction failure after 2.5–3 h. Recovery was not apparent after a further 3 h, and the block was located at the edges of the compressed region. Gelfan & Tarlov (1956) compressed 5 mm of dog sural nerve such that complete block of the compound potential was achieved in 41–62 min. Only partial recovery was found after a further 152 min. Gasser & Erlanger (1929) compressed 12 mm of amphibian nerve and saw extensive block of the compound action potential after 30 min. The common features of these investigations were that block of conduction (and recovery) were observed over a long time course and that, on the basis of compound action potential recordings, these authors concluded that the faster fibres were blocking first.

Finally, we need to assess the importance of these two distinct classes of deformation-induced conduction block to the clinical situation. Low compression block, as has been demonstrated in animal models, is probably the most common form of compression block encountered clinically. High compression, if applied for long periods, will undoubtedly produce extensive fibre damage. However, the question remains as to whether a peripheral nerve is commonly subjected to such high compression while axon continuity remains intact. Nerve damage following low compression block is well characterized histologically and we have provided evidence that, with low compression, the order of block determined electrophysiologically confers with these studies. That a block similar to *in vivo* compression block can be caused by a purely physical deformation of fibres appears to corroborate the view that these nerve lesions are due to fibre deformation rather than ischaemia. However, further studies, in which mechanical and ischaemic factors can be studied in isolation, are required before a detailed understanding of human compression neuropathies can be achieved.

REFERENCES

- AGUAYO, A., NAIR, C. P. V. & MIDGLEY, R. (1971). Experimental progressive compression neuropathy in the rabbit. *Archives of Neurology* **24**, 358–365.
- BENTLEY, F. H. & SCHLAPP, W. (1943). The effects of pressure on conduction in peripheral nerve. *Journal of Physiology* **102**, 72–82.
- BURKE, W., BURNE, J. A. & MARTIN, P. R. (1985). Selective block of Y optic nerve fibres in the cat and the occurrence of inhibition in the lateral geniculate nucleus. *Journal of Physiology* **364**, 81–92.
- BURKE, W., COTTEE, L. J., GARVEY, J., KUMARASINGHE, R. & KYRIACOU, C. (1986). Selective degeneration of optic nerve fibres in the cat produced by a pressure block. *Journal of Physiology* **376**, 461–476.
- CAUSEY, G. & PALMER, E. (1949). The effects of pressure on nerve conduction and nerve fibre size. *Journal of Physiology* **109**, 220–231.
- DENNY-BROWN, D. & BRENNER, C. (1944). Paralysis of nerve induced by direct pressure and by tourniquet. *Archives of Neurology and Psychiatry* **51**, 1–26.
- EDWARDS, D. J. & CATTELL, M. (1928). Further observations on decrement in nerve conduction. *American Journal of Physiology* **87**, 359–367.

- FERN, R. & HARRISON, P. J. (1989). The sequence of pressure-induced conduction failure of myelinated fibres in the isolated frog sciatic nerve (*Rana temporaria*) is dependent upon the pressure applied. *Journal of Physiology* **418**, 77P.
- GASSER, H. S. & ERLANGER, J. (1929). The role of fibre size in the establishment of a nerve block by pressure of cocaine. *American Journal of Physiology* **88**, 581-591.
- GELFAN, S. & TARLOW, I. M. (1956). Physiology of spinal cord, nerve root and peripheral nerve compression. *American Journal of Physiology* **185**, 217-229.
- LUNDBORG, G., GELBERMAN, R. H., MINTTEER-CONVERY, M., LEE, Y. F. & HARGENS, A. R. (1982). Median nerve compression in the carpal tunnel-functional response to experimentally induced controlled pressure. *Journal of Hand Surgery* **7**, 252-259.
- LUTTGES, M. W. (1973). Studies on parameters relating to spinal disfunction. In *Biomechanics Conference on the Spine*, ed. SUH, C. H., pp. 1-55. University of Colorado Press, Boulder, CO, USA.
- MACGREGOR, R. J., SHARPLES, S. K. & LUTTGES, M. W. (1975). A pressure vessel model for nerve compression. *Journal of Neurological Sciences* **24**, 299-304.
- OCHOA, J., FOWLER, T. L. & GILLIATT, R. W. (1972). Anatomical changes in peripheral nerves compressed by a pneumatic tourniquet. *Journal of Anatomy* **113**, 433-455.
- OKADA, Y. & MCDUGAL, B. D. JR (1971). Physiological and biochemical changes in frog sciatic nerve during anoxia and recovery. *Journal of Neurochemistry* **18**, 2335-2353.
- POWELL, H. C. & MYERS, R. R. (1986). Pathology of experimental nerve compression. *Laboratory Investigations* **55**, 91-100.
- SPINNER, M. & SPENCER, P. S. (1974). Nerve compression lesions of the upper extremity. A clinical and experimental review. *Clinical and Orthopaedic Related Research* **104**, 46-67.
- SUNDERLAND, S. (1978). *Nerve and Nerve Injury*, 2nd edn. Churchill Livingstone, Edinburgh.
- WEISS, P. & HISCOE, H. H. (1948). Experiments on the mechanism of nerve growth. *Journal of Experimental Zoology* **107**, 315-393.
- WRIGHT, E. B. (1946). A comparative study of the effects of oxygen lack on peripheral nerve. *American Journal of Physiology* **147**, 78-89.

ISCHAEMIC CONDUCTION BLOCK IN RELATION TO AXON DIAMETER AND FUNCTION

ROBERT FERN & P J HARRISON. Department of Physiology, University College London, Gower Street., London WC1E 6BT.

Damage to nerve produced by chronic compression may conceivably be due to ischaemia and/or to mechanical deformation of axons. A common feature of chronic compression is a loss of sensory transmission with relative sparing of motor function. While recordings of compound action potentials indicate that smaller myelinated axons tend to have the shortest survival times during ischaemia, nothing is known about the relative sensitivity of sensory and motor axons. Furthermore, compound action potentials are known to produce misleading results under some conditions. We have therefore performed a study of the effects of ischaemia (following circulatory arrest) upon single unitary potentials recorded from spinal roots in the cat. Our results indicate that axons block within 6-37 min (mean=18.7 minutes), of the onset of ischaemia and that smaller, slower conducting myelinated axons tend to fail first (n=204). When results from ventral and dorsal roots are considered separately, it is found that while average conduction velocity was not significantly different, average survival time was (t-test $p > 0.001$). As dorsal roots carry sensory axons and ventral roots carry motor axons, we conclude that sensory axons are more sensitive to ischaemia than are motor axons. This is a pattern similar to that found in chronic compression neuropathies, and appears to corroborate the view that ischaemia plays an important role in the development of these disorders.