

AN EXAMINATION OF MIDDLE BRONZE AGE II TYPOLOGY AND  
SEQUENCE DATING IN PALESTINE, WITH PARTICULAR  
REFERENCE TO THE TOMBS OF JERICHO AND FARA (SOUTH).

VOLUME TWO

by

David Price Williams

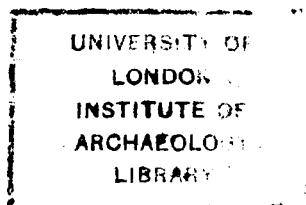

Submitted to the Faculty of Arts in fulfillment of the  
requirements for the degree of DOCTOR OF PHILOSOPHY at  
the Institute of Archaeology, University of London, 1975



## **IMAGING SERVICES NORTH**

Boston Spa, Wetherby  
West Yorkshire, LS23 7BQ  
[www.bl.uk](http://www.bl.uk)

**BEST COPY AVAILABLE.**

**VARIABLE PRINT QUALITY**

CONTENTS	VOLUME II	<u>Page</u>
Title Page .....		471
Contents.....		472
List of Tables .....		473
List of Figures .....		474
Tables .....		478
Figures .....		480

## LIST OF TABLES

1. Quantitative analyses of selected bronze objects



## LIST OF FIGURES

1.           A) Table of Similarity indexes  
              B) Schematically described lenticular occurrence
2.           Numeration of regrouped Jericho traits
3.           Presence/absence matrix of Jericho tombs
4.           Matrix of Jericho similarity indexes
5.           Two dimensional array of Ansim Jericho
6.           One dimensional array of Ansim Jericho
7.           Fig. 5 showing number of objects per tomb
8.           Two dimensional array of Jericho Normtest 1
9.           One dimensional array of Jericho Normtest 1
10.          Projection of Two dimensional to one dimensional array
11.          Two dimensional array of Jericho Normtest 2
12.          One dimensional array of Jericho Normtest 2
13.          Two dimensional array of Jericho Realrun 1
14.          Interlinked two dimensional array of Jericho Realrun I
15.          One dimensional array of Jericho Realrun I
16.          Second trial of Two dimensional array of Realrun 1
17.          Plan of Tell Fara MBII 500 Cemetery
18.          F545 Plan
19.          A) F545 Pottery   B) F545 Scarabs and Bronze
20.          F550 Plan
21.          F550 Pottery
22.          F550 Pottery
23.          A) F550 Scarabs   B) F550 Bronze, faience and bone
24.          F551 Plan
25.          F551 Pottery
26.          F551 Pottery

27. A) F551 Scarabs B) F551 Bronze and Bone
28. F554 Plan B) F554 Pottery
29. A) F554 Scarabs B) F554 Bronze and bone
30. F555 Plan
31. F555 Pottery
32. A) F555 Scarabs B) F555 Bronze and faience
33. F556 Plan
34. F556 Pottery
35. A) F556 Scarabs B) F556 Bronze and faience
36. F557 Pottery
37. A) F558 Plan B) F558 Pottery C) Scarabs & Bronze
38. F559 Plan
39. F559 Pottery
40. F559 Pottery cont.
41. A) F559 Scarabs B) F559 Bronze
42. F561 Pottery
43. A) F563 Plan B) F563 Pottery C) F563 Scarabs
44. F564 Pottery
45. F564 Scarabs B) F564 Bronze, bone and alabaster
46. F565 Plan
47. F565 Pottery
48. A) F565 Scarabs B) F565 Faience & bone
49. F566 Plan
50. F566 Pottery
51. F567 Plan
52. A) F567 Pottery B) F567 Scarabs C) F567 Bronze
53. F569 Plan
54. F569 Pottery
55. A) F569 Pottery cont. B) F569 Scarabs C) F569 Bronze  
bone and alabaster.

56. A) F570 Plan B) F570 Pottery
57. A) F570 Scarabs B) F570 Bronze and bone
58. A) F571 Plan B) F571 Pottery
59. A) F574 Plan B) F574 Scarab
60. A) F575 Plan B) F575 Pottery
61. F576 Plan
62. A) F577 Plan B) F577 Pottery
63. F578 Plan
64. F578 Pottery
65. A) F579 Plan B) F579 Pottery
66. A) F581 Plan B) F581 Pottery
67. F582 Plan
68. A) F582 Pottery B) F582 Scarabs C) F582 Faience  
and bone.
69. F583 Pottery
70. A) F584 Plan B) F584 Pottery
71. A) F584 Scarabs B) F584 Faience
72. A) F586 Plan B) F586 Pottery
73. A) F587 Plan B) F587 Pottery C) F587 Scarab
74. A) F590 Plan B) F590 Pottery
75. F590 Scarabs
76. F593 Plan
77. A) F583 Pottery B) F593 Scarabs and bronze
78. A) F594 Plan B) F594 Pottery
79. A) F595 Plan B) F595 Pottery
80. F596 Plan
81. A) F596 Pottery B) F596 Scarabs C) F596 Bronze  
and flint fragments.

82.            Tabulation of Tomb type 1

The remaining four figures are on large sheets and are to be found in the back of this volume

83.            Tabulation of Tomb type 2

84.            Tabulation of Tomb type 3

85.            Tabulation of Tomb type 4

86.            Tabulation of Tomb type 5

**TABLES**

TABLE 1

## Quantitative Analysis

	Cu	Pb	Sn	Ag	Fe	Sb	Ni	Co	As	Zn	Bi
1.	99.0	0.07	0.02	0.02	0.75	n.d.	0.2	0.04	2.0	n.d.	n.d.
2.	93.0	0.14	tr	0.02	0.67	n.d.	0.06	n.d.	0.4	n.d.	n.d.
3.	93.0	0.32	0.46	0.02	1.20	0.05	0.04	.005	3.3	tr	n.d.
4.	97.5	0.41	tr	0.02	0.17	n.d.	0.03	n.d.	2.3	n.d.	0.05
5.	92.8	0.30	5.7	0.16	0.16	n.d.	0.15	n.d.	0.3	n.d.	n.d.
6.	85.4	0.25	8.8	0.05	0.20	n.d.	0.15	n.d.	3.5	0.03	n.d.
7.	91.0	1.70	4.6	0.03	0.20	n.d.	0.08	n.d.	tr	n.d.	n.d.
8.	96.5	0.02	tr	0.01	0.07	n.d.	0.04	n.d.	1.3	n.d.	n.d.
9.	98.8	0.07	0.02	0.09	0.64	n.d.	n.d.	n.d.	tr	n.d.	n.d.
10.	93.0	0.50	6.2	0.06	0.30	n.d.	0.08	n.d.	1.0	n.d.	n.d.
11.	84.8	0.24	4.3	0.01	0.16	n.d.	0.07	.003	0.2	11.2	n.d.
12.	85.4	0.33	7.0	0.03	0.14	n.d.	0.05	.007	0.7	tr	n.d.
13.	93.5	n.d.	0.4	0.01	1.05	n.d.	0.01	n.d.	1.7	tr	n.d.
14.	85.6	0.41	7.6	0.01	0.17	n.d.	0.10	.006	0.3	tr	n.d.
15.	90.3	0.72	8.6	0.02	0.10	n.d.	0.15	.005	0.1	tr	n.d.
16.	92.6	0.02	0.3	0.02	1.50	n.d.	0.07	.005	2.4	0.02	n.d.
17.	95.4	0.19	0.3	0.03	0.85	0.03	0.03	.003	2.1	0.01	n.d.

## Semi-quantitative

	Cu	Pb	Sn	As
18.	75	0.05	2.3	0.1
19.	71	0.08	7.6	0.2
20.	61	0.4	5.6	0.3
21.	50	0.9	2.6	0.1
22.	75	1.1	7.0	0.1
23.	81	0.3	5.7	0.2

n.d. = not detected

tr. = Present below 0.01%

**FIGURES**

	I	II	III	IV	V	VI	VII
I		6	5	4	3	2	1
II	6		6	5	4	3	2
III	5	6		6	5	4	3
IV	4	5	6		6	5	4
V	3	4	5	6		6	5
VI	2	3	4	5	6		6
VII	1	2	3	4	5	6	

A

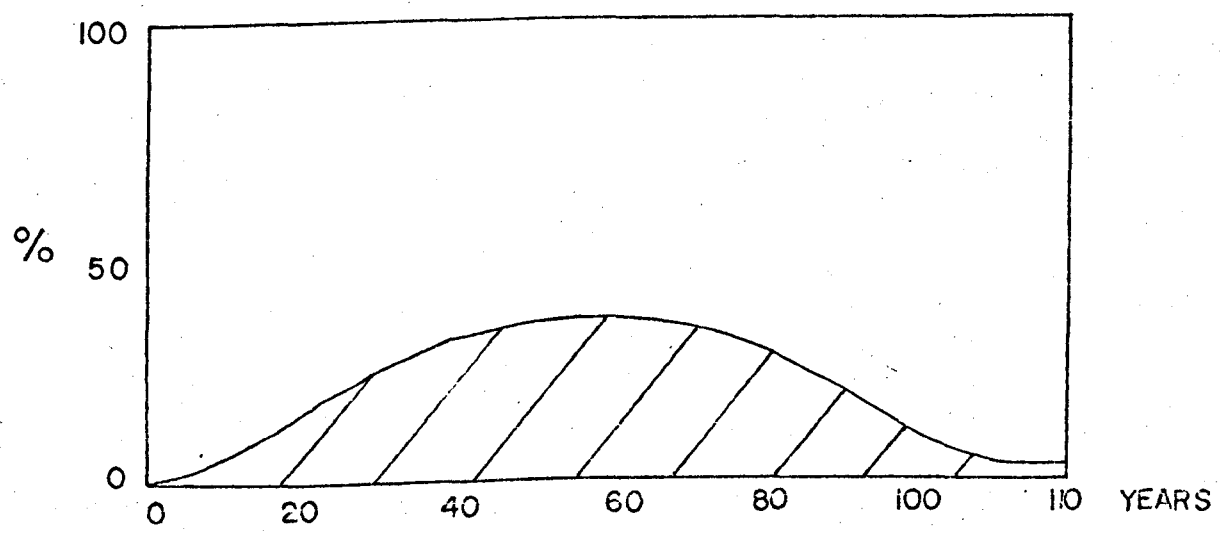

FIG. 1 B



Trait No.	Object	Trait No.	Object
1	Bowls A1	31	Lamps A-D
2	Bowls A2	32	Lamps E/F
3	Bowls A3	33	Lamps G-J
4	Bowls B1	34	Storage Jars
5	Bowls B2	35	Alabastra A1
6	Bowls B3	36	Alabastra A2
7	Bowls B5	37	Alabastra A4/5
8	Bowls B6	38	Alabastra B/C
9	Bowls B7	39	Alabastra D1/4
10	Bowls C1	40	Alabastra D3
11	Bowls D1-3	41	Alabastra E
12	Bowls D4	42	Faience A
13	Bowls F1	43	Toggle pins A/B
14	Bowls F2/3	44	Toggle pins C-E
15	Bowls F4/7	45	Toggle pins F/G
16	Bowls G	46	Combs
17	Bowls H	47	Wooden Bowls
18	Ped. vases A	48	Wooden tables
19	Ped. vases B	49	Wooden stool/bed
20	Ped. vases C	50	Dagger
21	Piriform Ala/b/2b	51	Scarabs
22	Piriform Bla	52	Baskets
23	Piriform Cla/2a/E1a <sup>E2a</sup>	53	Bone inlay (edging)
24	Piriform Fla/2a	54	Bone inlay (centre)
25	Piri. Flb/2b/E1b/2b	55	Beads
26	Piri. Fld/2d/E1d/2d	56	Bone buttons/whorls
27	Piriform Gla/2a	57	Bowls J
28	Cylindrical A	58	Piriform H
29	Cylindrical B	59	Ostrich Eggs
30	Dippers	60	Knives

FIG.2

1 2 3 4 5 6 7 8 9 10 11 12 13 14 15 16 17 18 19 20 21 22 23 24 25 26 27 28 29 30 31 32 33 34 35 36 37 38 39 40 41 42 43 44 45 46 47 48 49 50 51 52 53 54 55 56 57 58 59 60

```

P23F 1 0 1 0 0 1 0 0 0 0 1 1 1 0 0 0 0 0 1 0 0 0 0 0 1 1 1 0 0 0 1 1 0 1 1 0 0 1 0 0 0 0 0 0 0 0 1 1 1 1 0 0 1 1 0 1 1 1 0 0 0 0
B35F 0 0 0 0 0 0 0 0 0 0 0 1 0 0 0 0 0 1 1 0 0 0 0 1 0 0 1 0 0 0 1 1 1 1 1 0 1 1 0 0 0 0 0 0 0 0 0 0 0 0 0 0 1 0 0 0 0 0 0 0 0
D22F 1 0 1 1 0 0 1 0 1 1 0 0 0 0 0 1 1 0 0 0 0 0 0 0 1 0 1 0 1 1 0 0 0 1 0 1 0 0 0 0 0 0 0 0 0 0 0 0 0 0 0 0 0 0 0 0 0 0 1 0 0 1
P17  0 0 1 0 0 1 0 0 0 0 1 0 0 1 0 0 0 1 0 0 0 1 0 0 1 1 0 1 0 1 1 0 1 0 1 0 1 0 1 0 0 0 1 0 1 0 0 0 0 0 1 1 0 1 1 0 0 1 0 0
J3   1 0 0 1 0 0 0 0 0 1 0 0 0 0 0 1 1 0 0 0 0 1 0 1 0 0 0 0 0 0 0 0 0 0 0 0 0 0 1 0 0 0 0 1 0 0 0 0 0 0 1 0 1 1 0 0 0 0 0 1 0 0 0
H18F 1 0 0 0 0 0 0 0 0 0 1 0 0 1 0 0 0 0 1 1 0 0 0 0 0 0 0 0 1 1 1 0 0 1 0 0 0 0 0 0 1 1 1 1 0 0 1 1 1 1 0 1 1 0 1 1 0 0 0 0 0
P21  0 1 1 0 0 0 0 0 0 0 0 1 1 0 1 0 0 1 1 1 0 0 0 0 0 0 0 0 1 1 1 0 1 1 0 0 0 0 0 0 0 0 0 0 0 0 0 0 0 0 0 0 1 0 0 0 1 0 1 0 0 0 1 0
G1F  0 0 1 0 0 0 0 1 0 0 0 1 0 0 1 0 0 0 0 0 0 0 0 0 0 0 0 0 0 1 1 1 1 0 1 0 1 0 0 0 1 0 0 0 0 0 0 0 0 0 0 0 0 0 0 0 0 0 0 0 0 0 0
B3F  0 0 1 0 0 0 0 1 0 0 0 0 0 0 0 0 0 0 1 0 1 0 0 0 0 1 0 0 0 0 0 0 0 0 0 0 0 0 0 0 0 0 0 0 0 0 0 0 0 0 0 0 0 1 0 0 0 0 0 0 1 0 0
J14F 0 1 0 0 1 0 0 0 1 0 0 1 0 0 0 0 1 1 1 1 0 0 0 0 0 0 0 0 1 1 1 1 1 0 1 1 0 0 1 0 0 0 0 0 1 1 0 0 0 0 0 1 0 1 0 1 0 1 0 1 0 0 0
H6F  1 1 0 0 0 1 0 0 0 0 0 1 0 1 0 0 0 1 1 1 0 0 0 0 0 0 0 0 0 1 1 0 0 1 0 0 1 0 1 1 0 0 1 0 0 1 0 1 1 0 1 0 0 1 1 0 0 0 0 0 0 0 0
H22  0 0 1 0 0 0 0 0 0 0 0 1 0 0 1 0 0 0 1 1 0 0 0 0 0 0 0 0 1 1 1 0 1 1 0 1 0 1 0 1 0 1 1 1 0 1 0 1 0 0 1 1 0 1 0 0 0 0 0 0
P19  1 0 0 0 0 0 0 0 0 0 1 1 0 1 1 0 0 1 0 1 0 0 0 1 0 0 0 0 0 1 1 0 1 1 1 0 0 0 0 0 1 0 1 0 0 1 1 1 1 0 1 1 0 1 1 1 0 0 1 1
B482r 1 0 0 0 0 0 0 0 0 0 0 0 0 0 0 0 0 0 0 0 1 1 0 1 0 0 0 0 0 0 0 0 0 0 0 0 0 0 0 0 0 0 0 0 0 0 0 0 0 0 0 0 0 0 1 0 0 0 1 0 1 0 1 0 1 0
J54F  0 0 1 0 0 0 0 0 0 0 0 0 0 0 0 0 1 0 0 0 1 0 0 1 0 0 0 0 0 1 0 0 1 1 0 0 0 0 0 0 0 0 0 0 0 0 0 0 0 0 0 0 0 0 0 0 0 0 0 0 0 0 0
J9F  0 1 0 0 1 0 0 1 0 0 0 0 0 0 0 0 0 0 0 0 1 0 0 0 0 0 0 0 0 1 1 0 1 1 1 0 0 0 0 1 0 0 0 1 1 1 0 0 0 0 0 1 0 1 0 1 0 0 0 0 0
B50EF 0 1 0 0 0 1 0 0 0 0 0 0 0 0 0 0 1 1 0 0 0 1 0 0 0 1 0 0 0 1 1 1 0 1 0 0 0 0 0 0 0 0 0 0 0 0 1 1 1 0 0 1 0 1 0 1 0 1 1 0 0
D13  0 0 1 1 1 0 0 0 0 0 1 0 1 0 0 0 1 0 0 0 0 0 0 0 0 0 0 0 0 1 1 0 0 1 0 1 0 0 0 0 0 0 0 0 0 0 0 0 0 0 0 0 0 0 0 0 0 0 0 0 0
G73F  0 1 1 0 0 0 1 1 0 0 1 1 1 0 1 0 0 0 1 1 0 0 0 0 0 0 0 0 0 1 1 1 1 0 1 0 0 0 0 0 0 0 0 0 0 0 0 0 0 0 0 0 0 0 0 0 0 0 0 0 0 0 0

```

FIG. 3

1.	2.	3.	4.	5.	6.	7.	8.	9.	10.	11.	12.	13.	14.	15.	16.	17.	18.	19.
1.	1246	851	1889	551	1969	1591	1015	772	1704	2029	1882	2325	576	690	1300	1637	1215	2164
2.	1246	556	1051	370	1049	946	658	460	1088	1141	1099	1246	286	426	802	976	774	1220
3.	851	556	706	383	757	667	498	341	789	762	793	864	241	338	563	673	568	877
4.	1889	1051	706	433	1628	1305	839	679	1485	1724	1544	1899	472	558	1136	1399	1051	1763
5.	551	370	383	433	518	370	274	194	477	510	492	590	192	210	327	456	366	521
6.	1969	1049	757	1628	518	1475	939	668	1572	1924	1829	2178	540	598	1227	1442	1054	2033
7.	1591	946	667	1305	370	1475	870	596	1449	1532	1506	1708	422	547	1111	1228	933	1741
8.	1015	658	498	839	274	939	870	403	938	963	1026	1058	226	362	718	781	655	1138
9.	772	460	341	679	194	668	596	403	663	706	683	774	177	253	515	593	467	800
10.	1704	1088	789	1485	477	1572	1449	938	663	1668	1615	1791	468	574	1296	1432	1071	1868
11.	2029	1141	762	1724	510	1924	1532	963	706	1668	1824	2177	531	619	1285	1523	1129	2026
12.	1882	1099	793	1544	492	1829	1506	1026	683	1615	1824	2035	452	614	1249	1380	1097	2017
13.	2325	1246	864	1899	590	2178	1708	1058	774	1791	2177	2035	644	719	1382	1664	1234	2288
14.	576	286	241	472	192	540	422	226	177	468	531	452	644	191	365	473	274	562
15.	690	426	338	558	210	596	547	362	253	574	619	614	719	191	440	512	410	675
16.	1300	802	563	1136	327	1227	1111	718	515	1296	1285	1249	1382	365	440	1070	793	1449
17.	1637	976	673	1399	456	1442	1228	781	593	1432	1523	1380	1664	473	512	1070	916	1675
18.	1215	774	568	1051	366	1054	933	655	467	1071	1129	1097	1234	274	410	793	916	1201
19.	2164	1220	877	1763	521	2033	1741	1138	800	1868	2026	2017	2288	562	675	1449	1675	1201



Strain = 0.015004

FIG. 5

9

3

15  
16

14  
10  
6  
12  
4  
19  
11

13  
7

17

18  
2

8

5

Strain = 0.042427

FIG.6

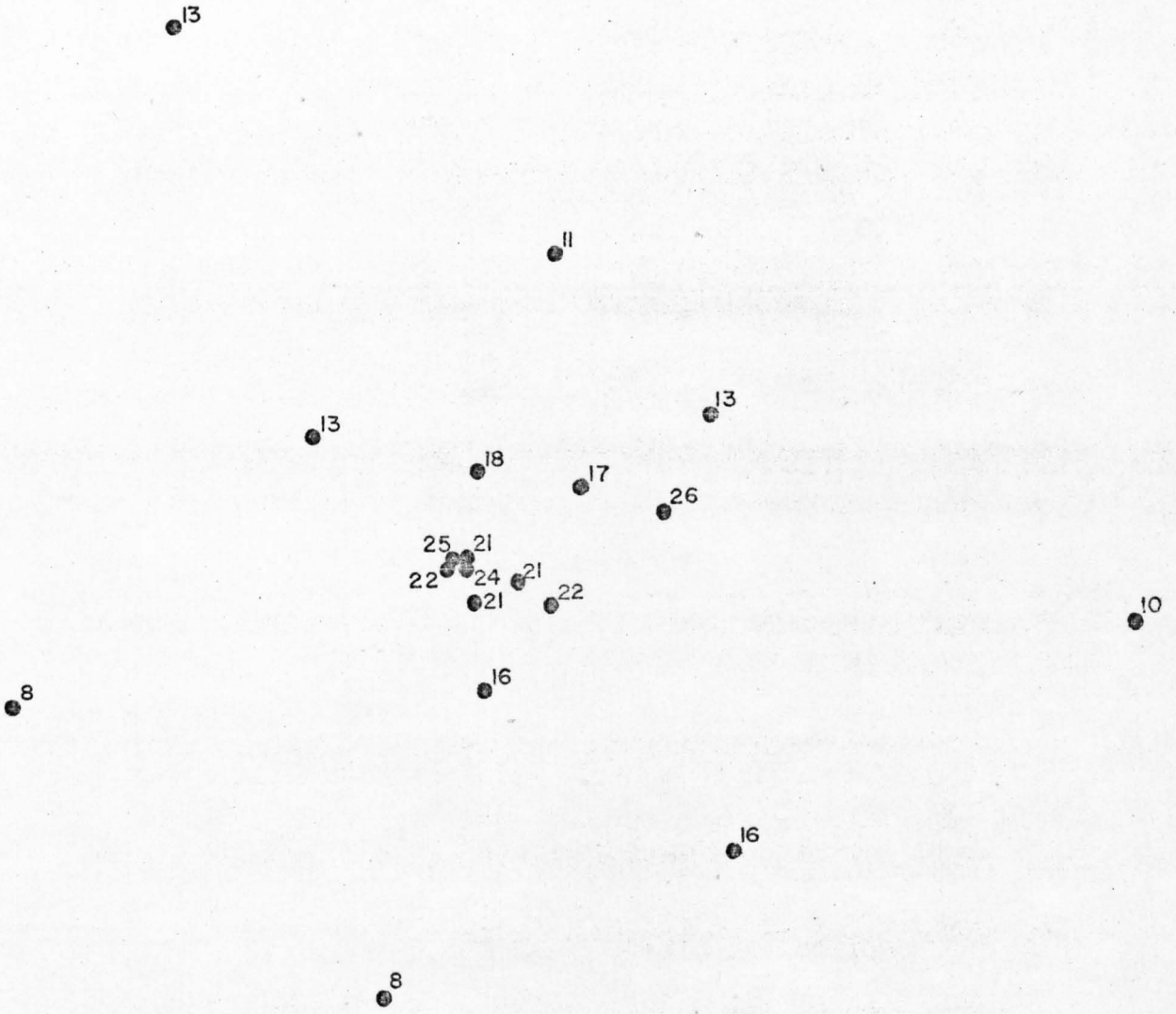

Strain = 0.015004

FIG. 7

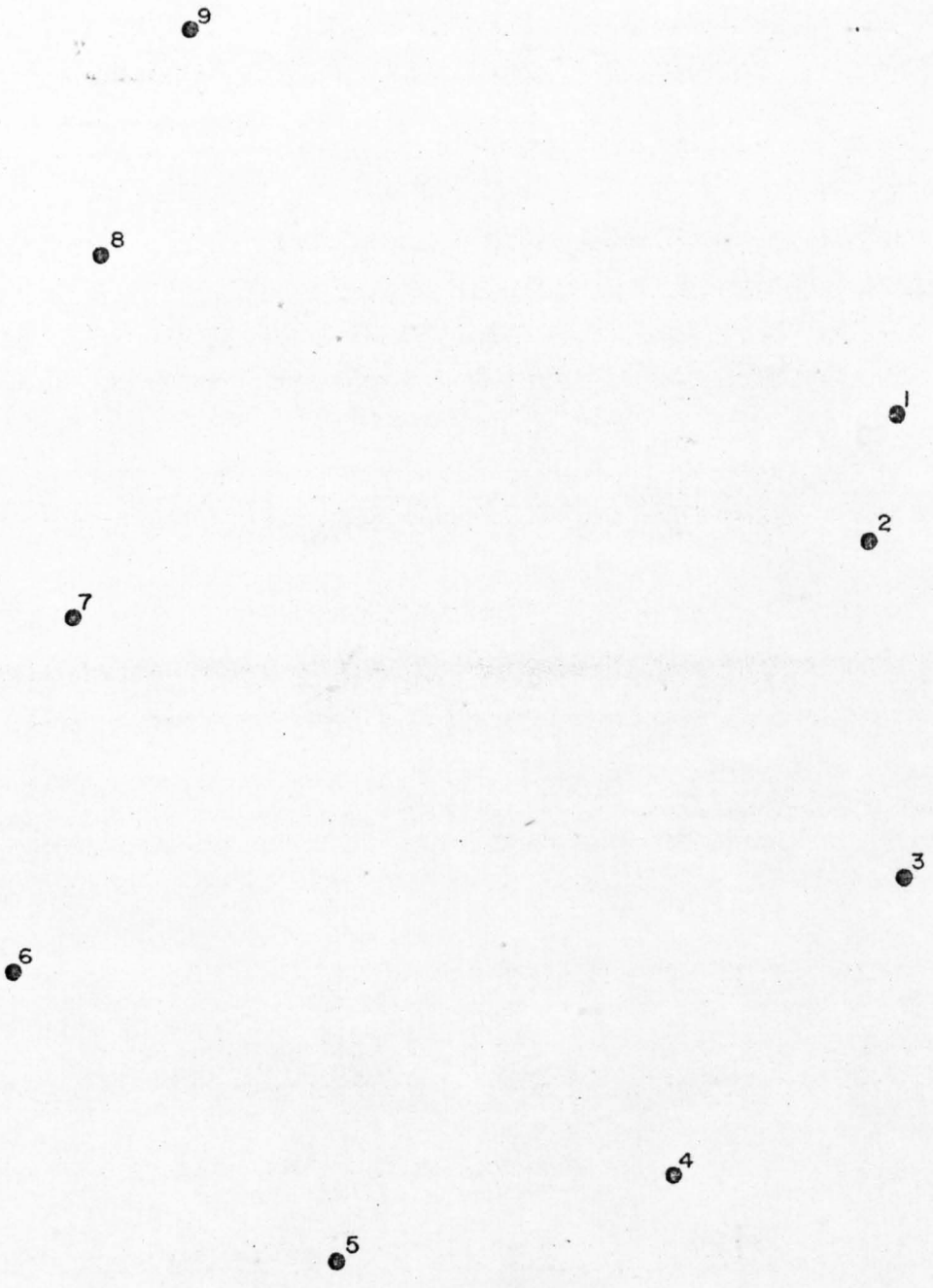

Strain = 0.000000

FIG. 8

9

8

1

2

3

7

6

5

4

Strain = 0.097164

FIG.9



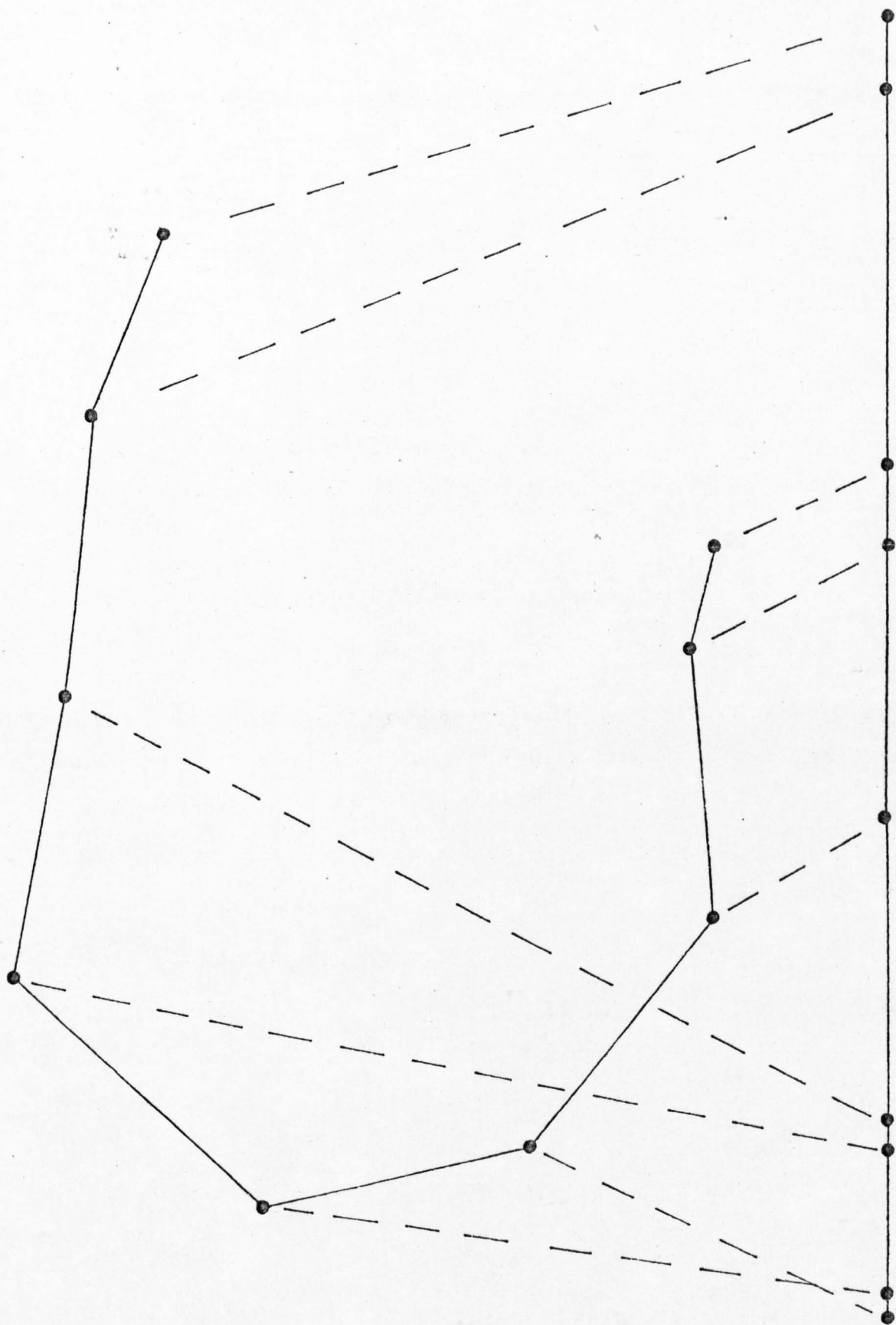
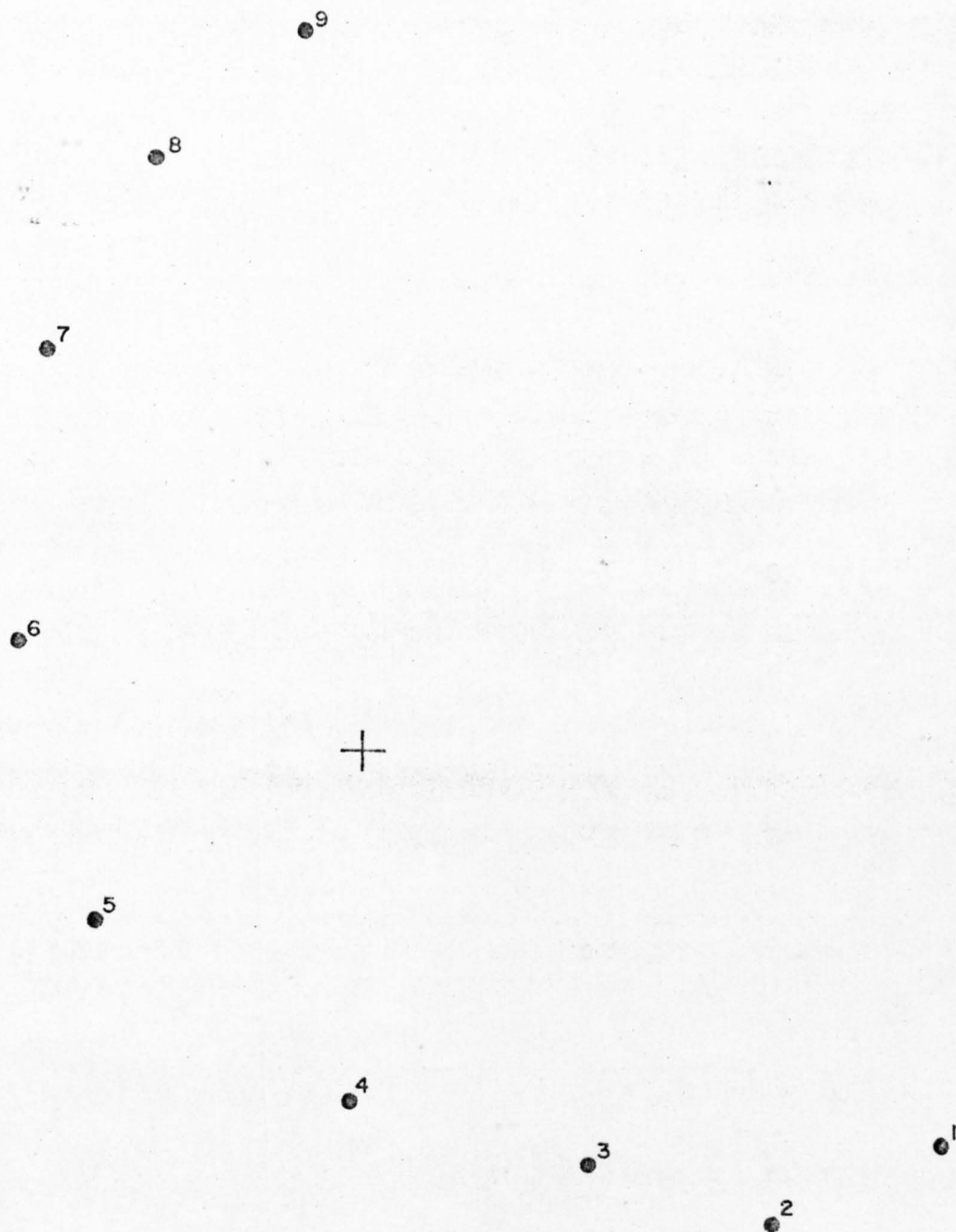

FIG.10



Strain = 0.000000

FIG.11

9

8

7

6

5

4

3

2

1

Strain = 0.000000

FIG.12

5

14

3

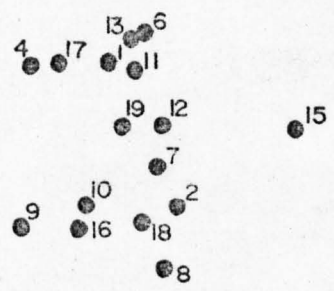

Strain = 0.009832

FIG.13

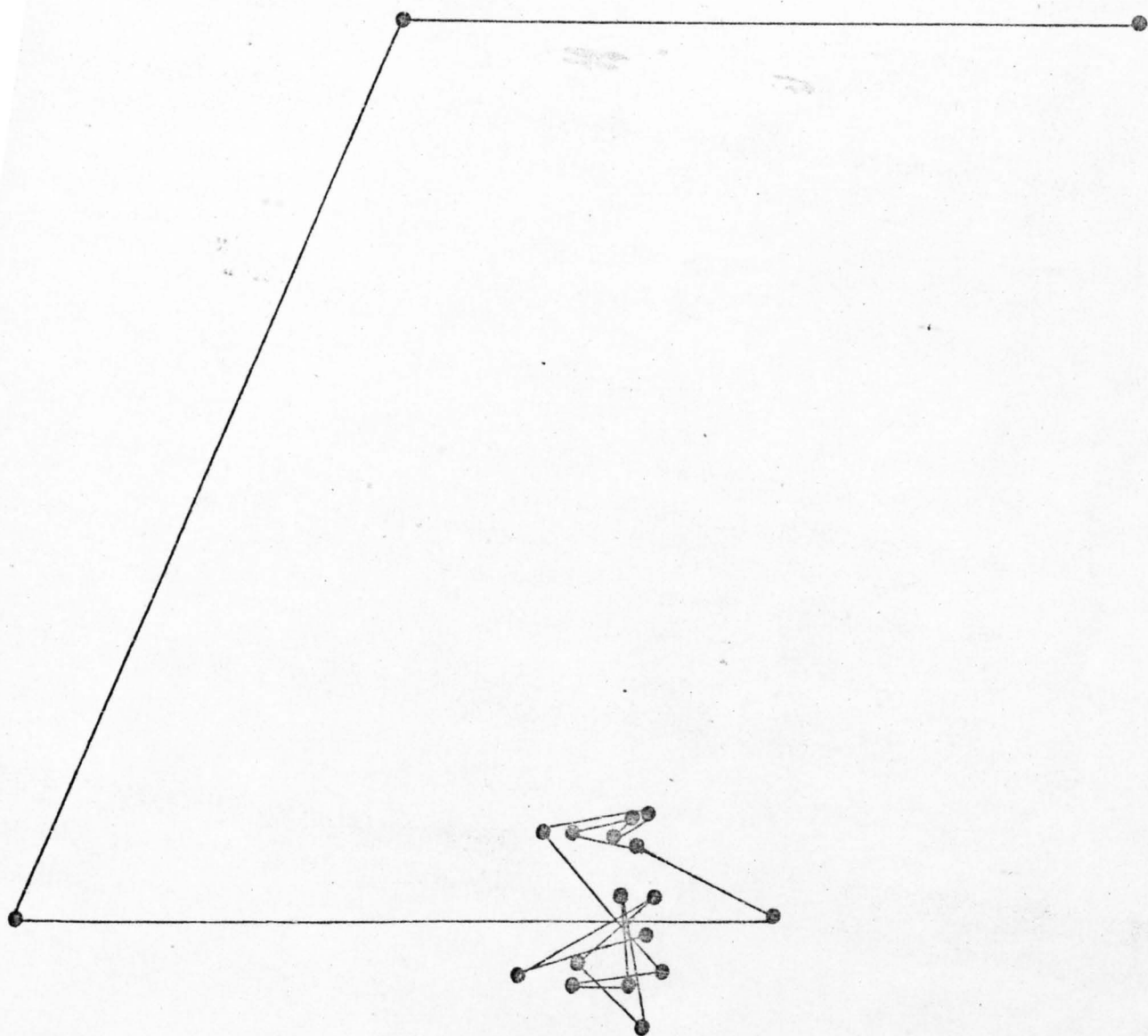

Strain = 009832

FIG.14

5

4

3

15

11

9

7

17

13

1

6

4

2

16

18

19

8

10

12

Strain = 0.013740

FIG.15



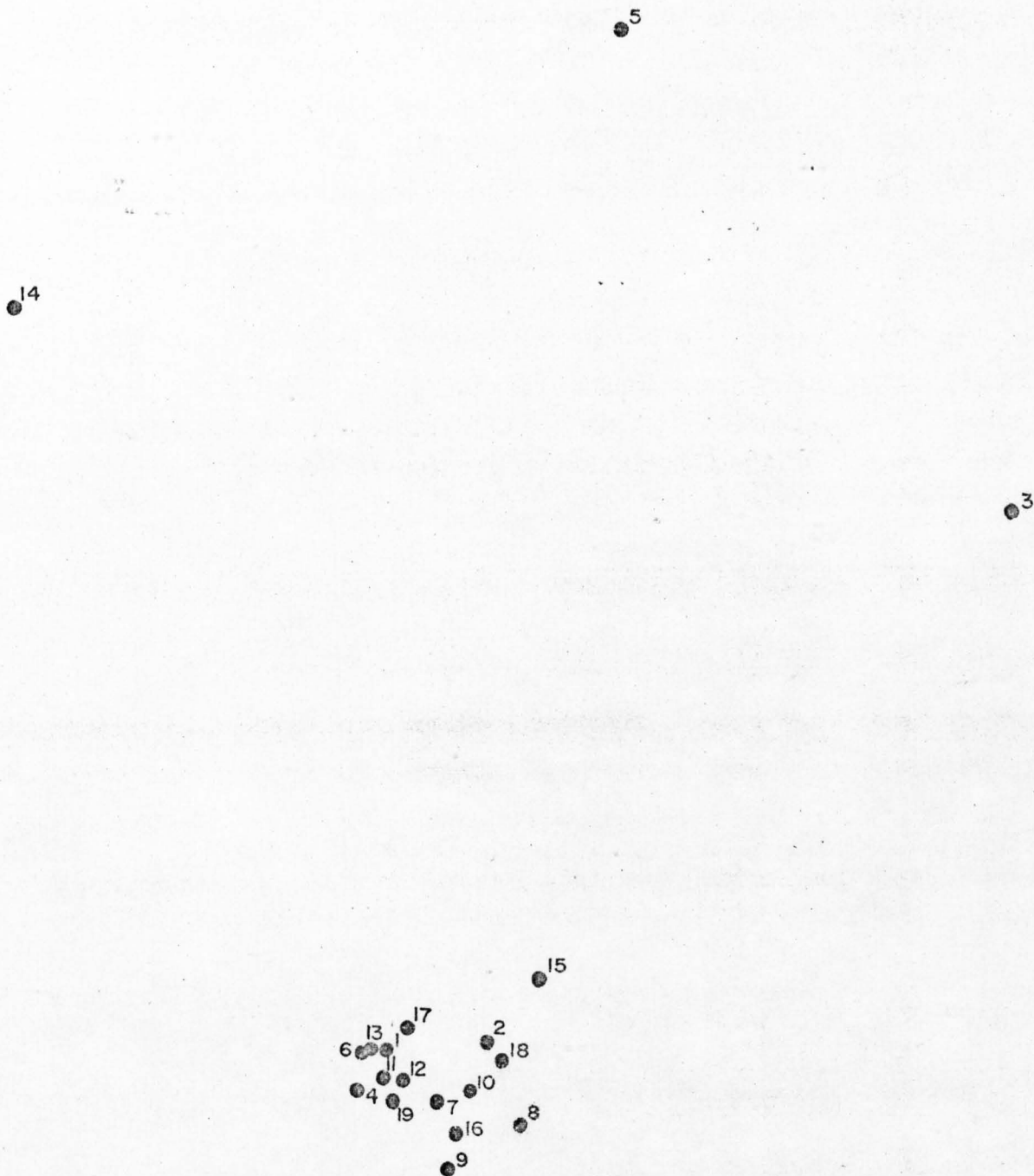

Strain = 0.004880

FIG.16

△h

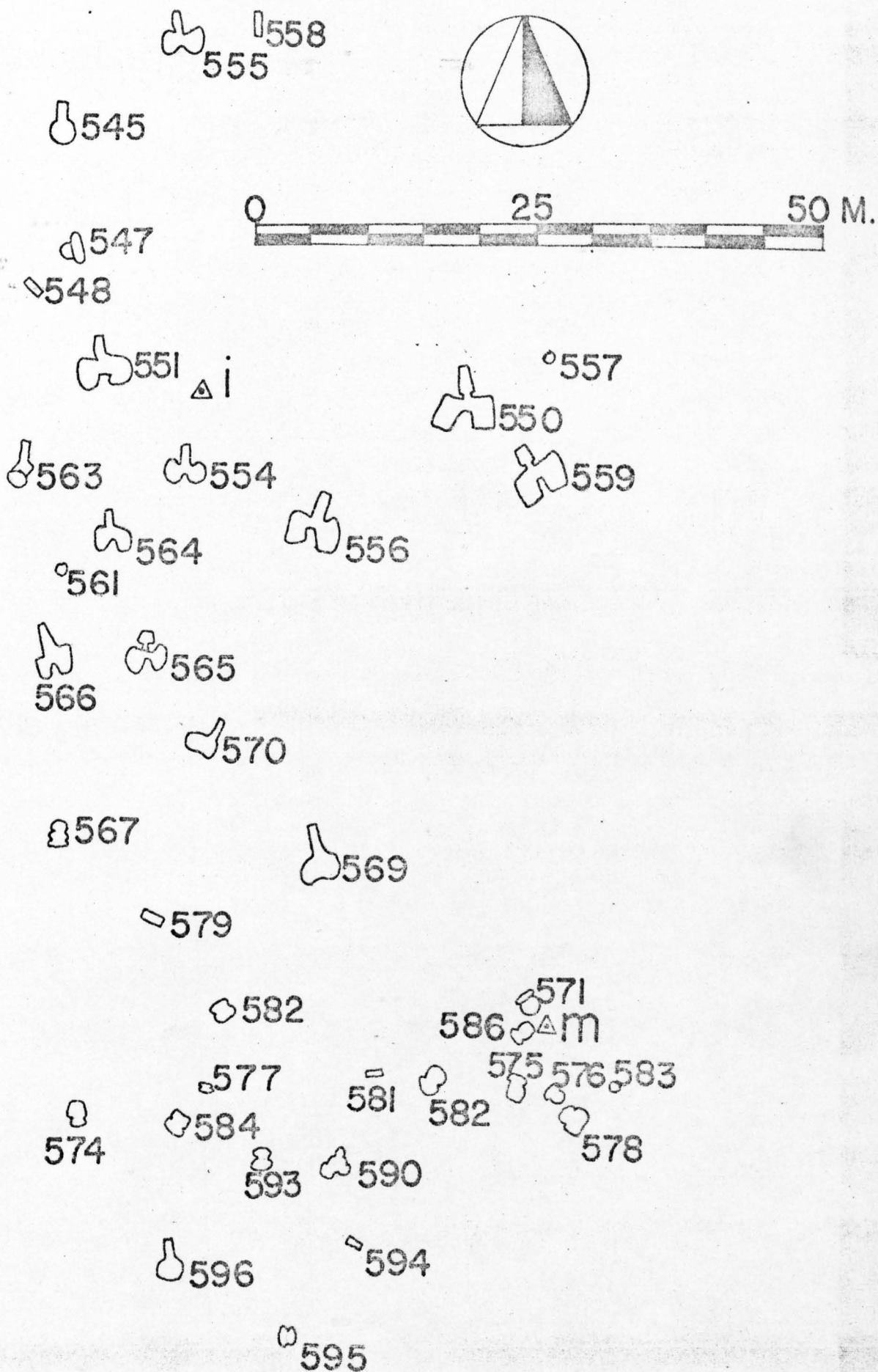
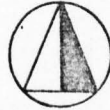
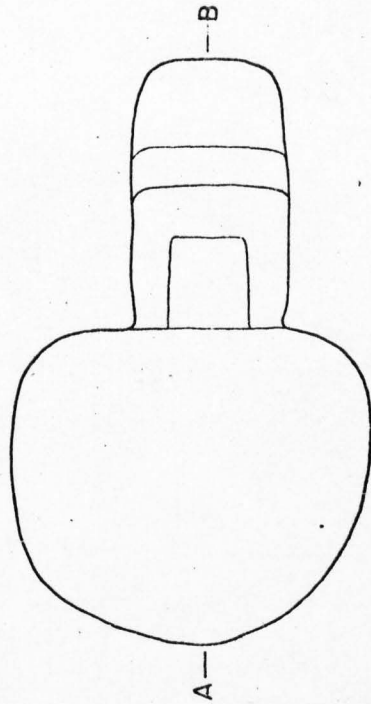

FIG.17



F545  
Plan



Section

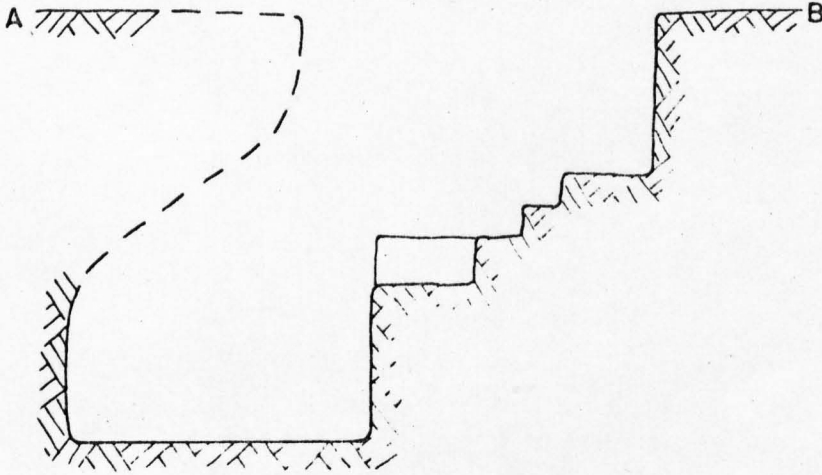
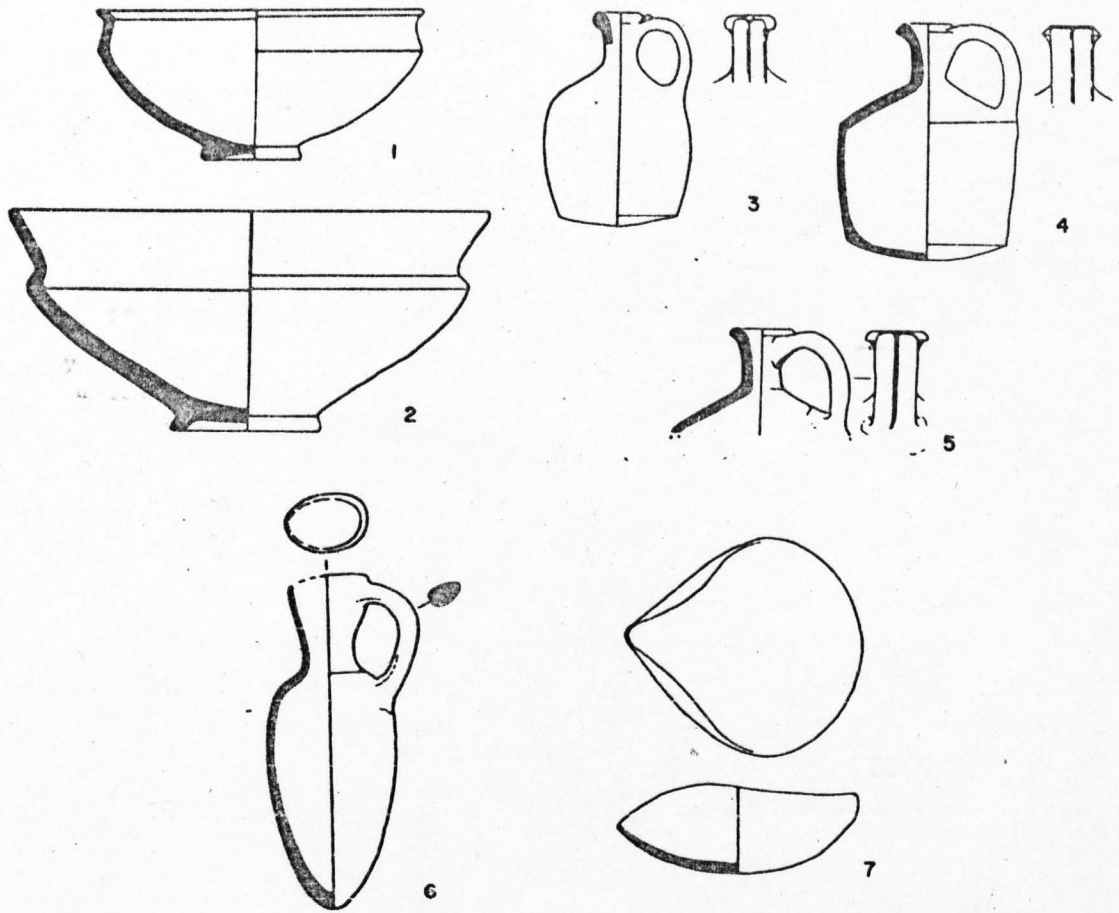
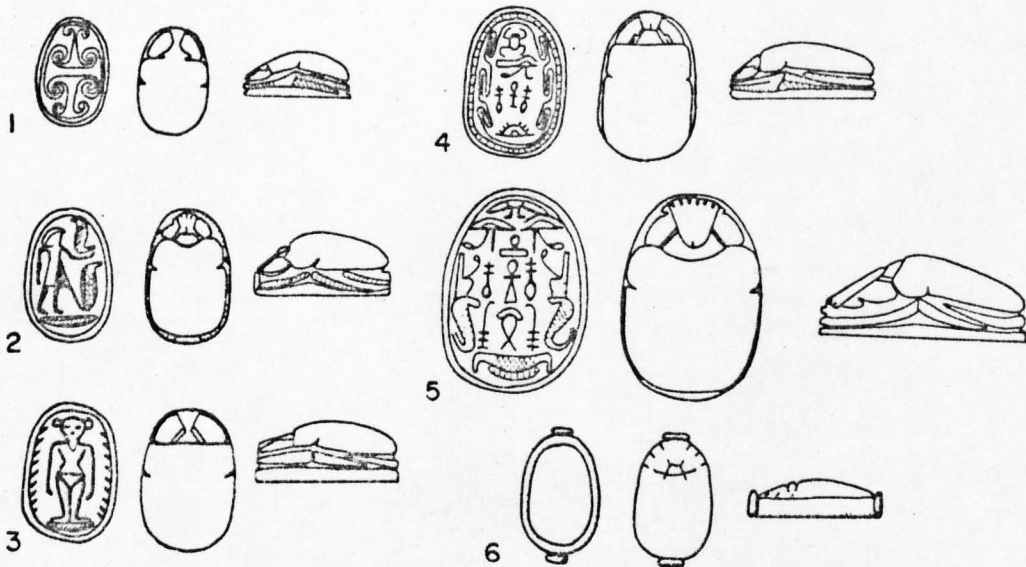

FIG.18



1/4

FIG.19A



1/1

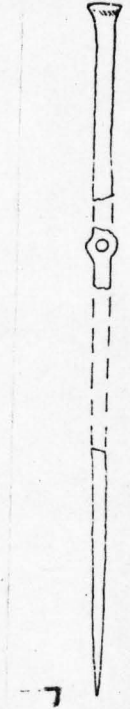

1/2

FIG.19B

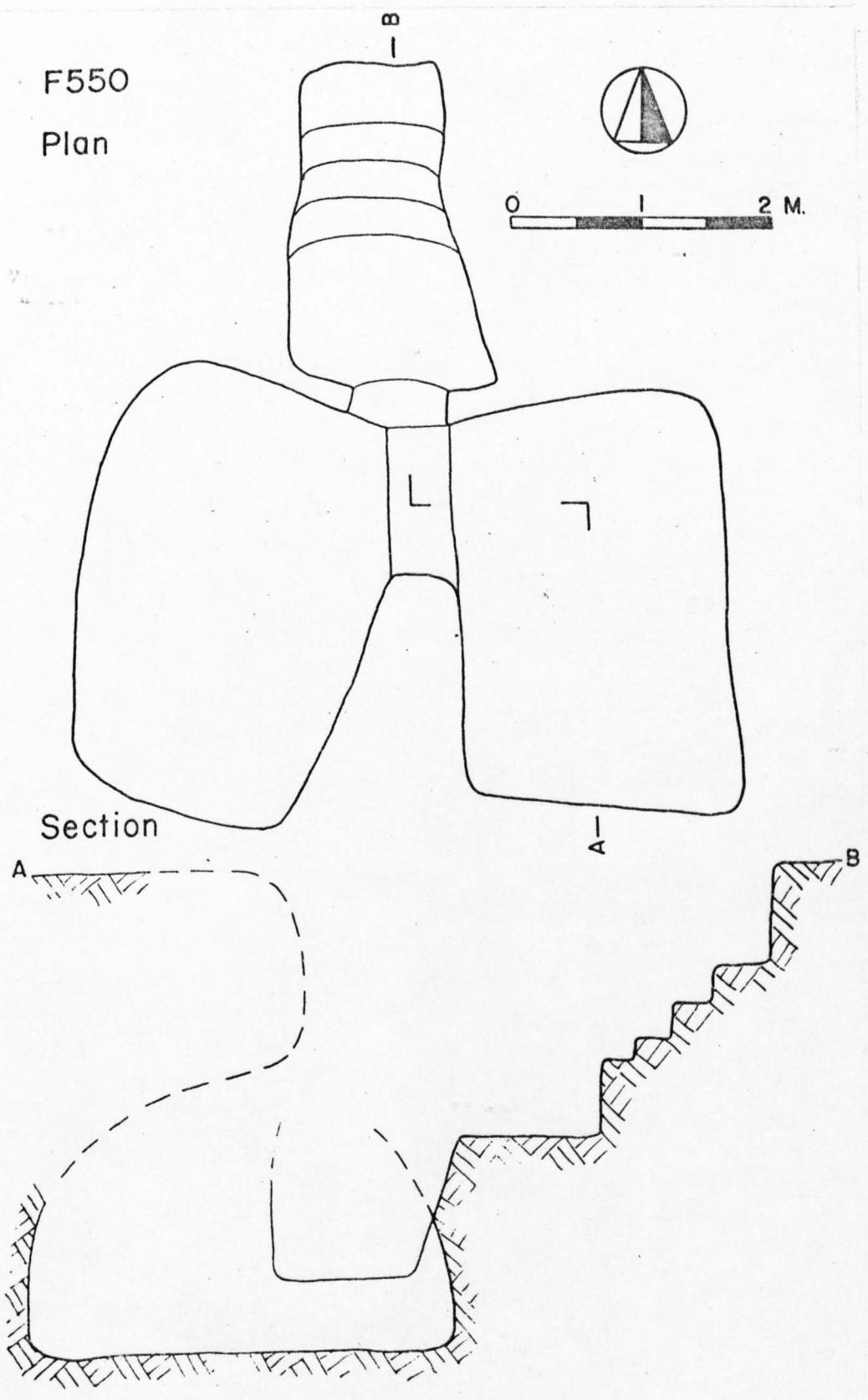
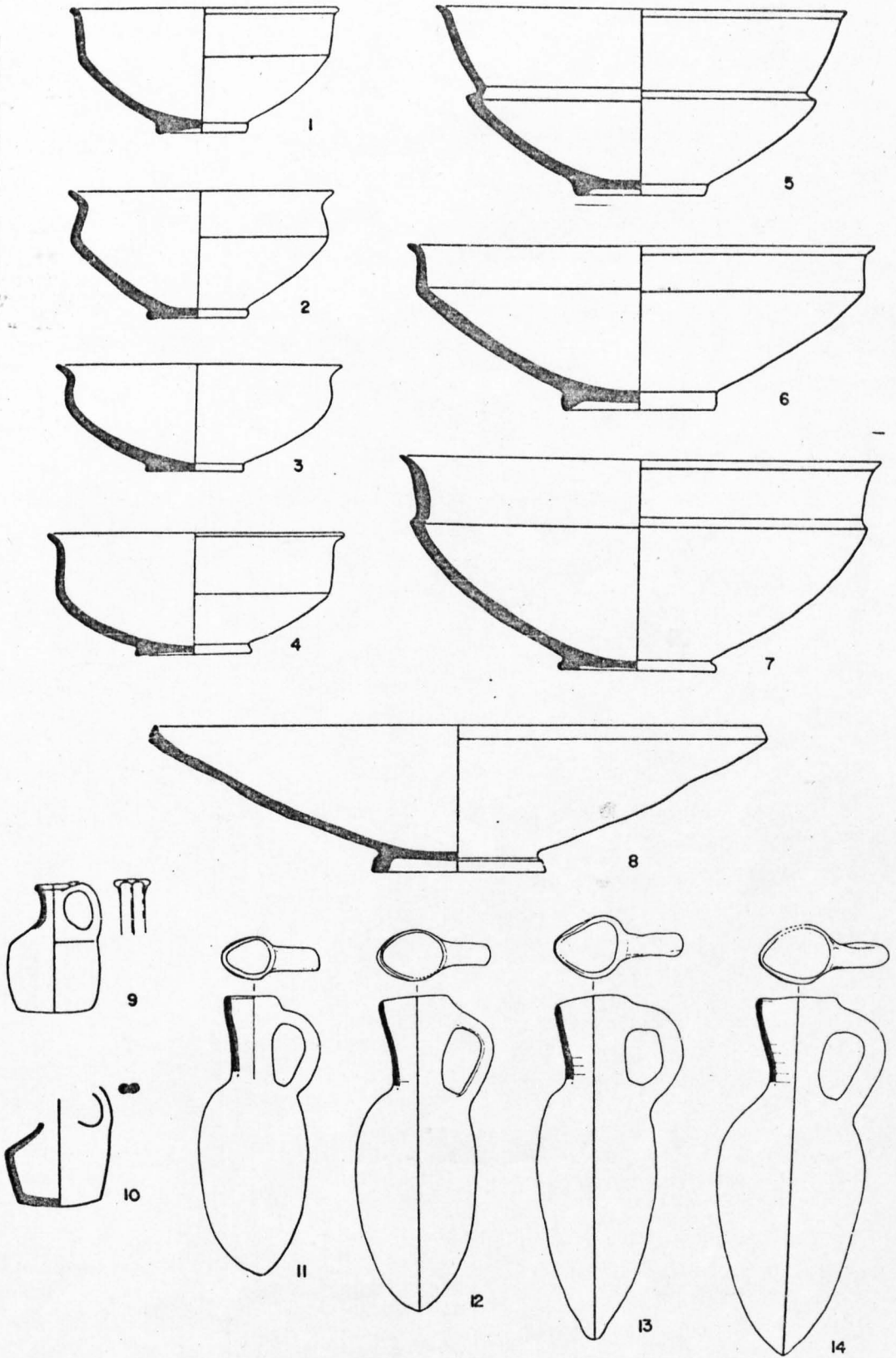

FIG. 20



1/4

FIG. 21

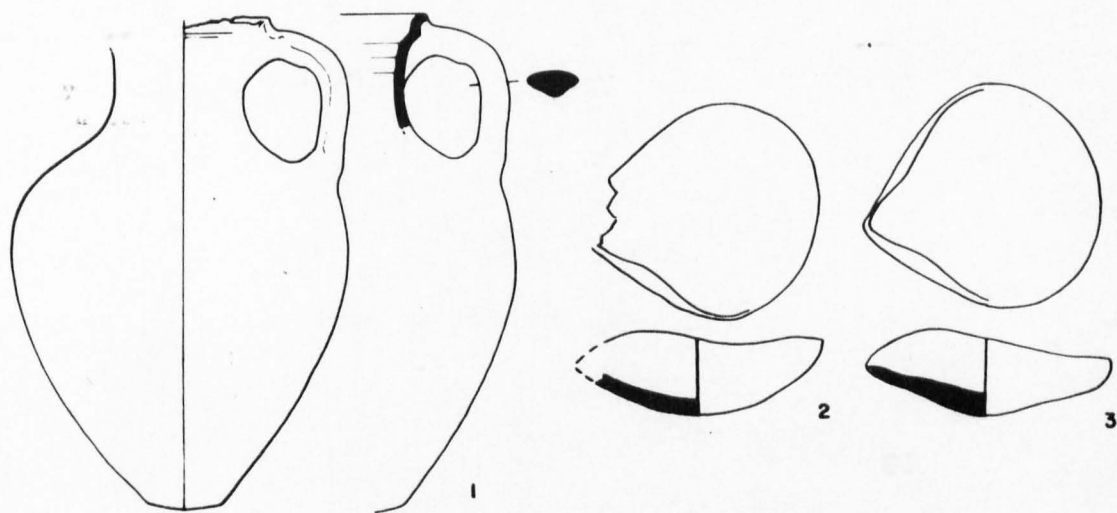
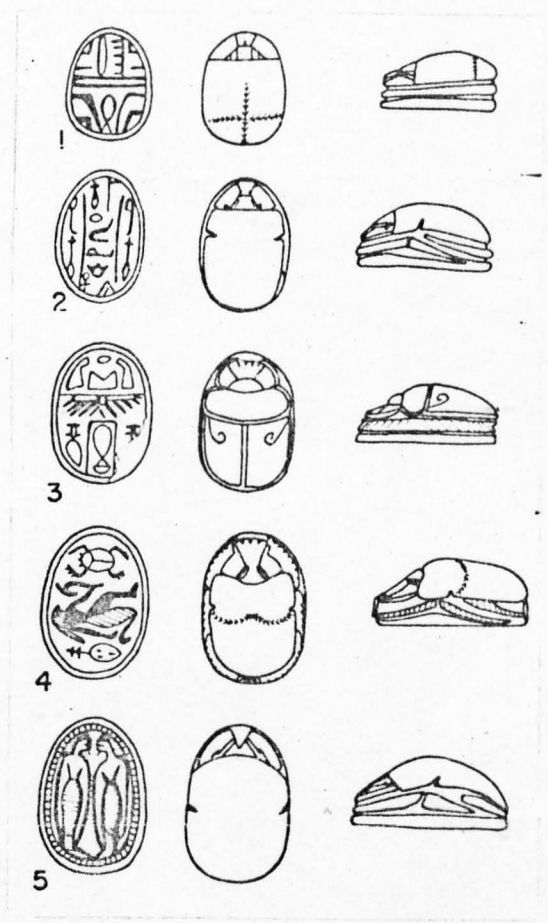
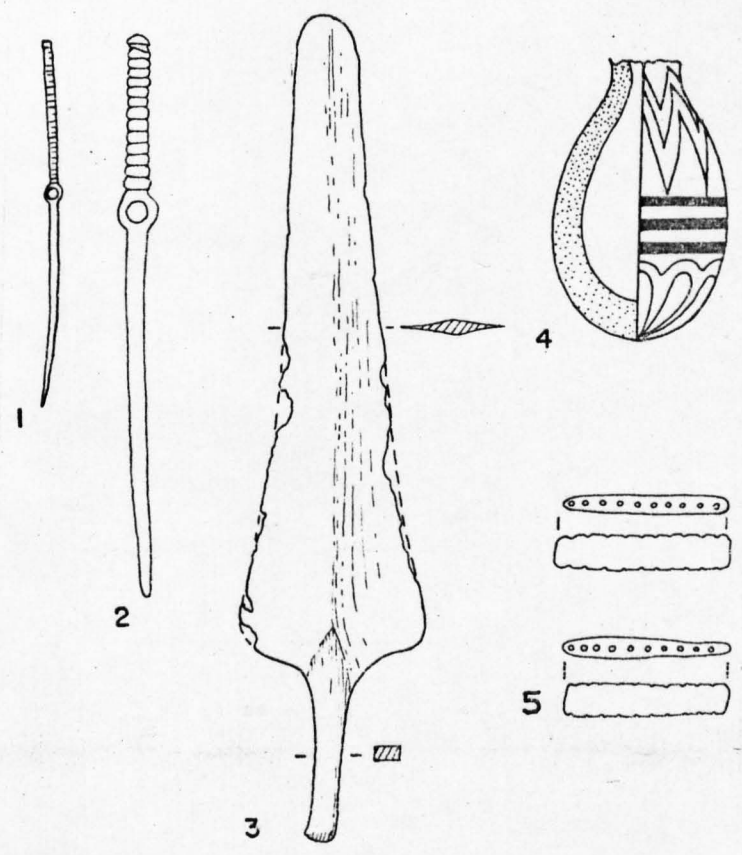

FIG. 22





1/1 FIG.23A



1/2 FIG.23B

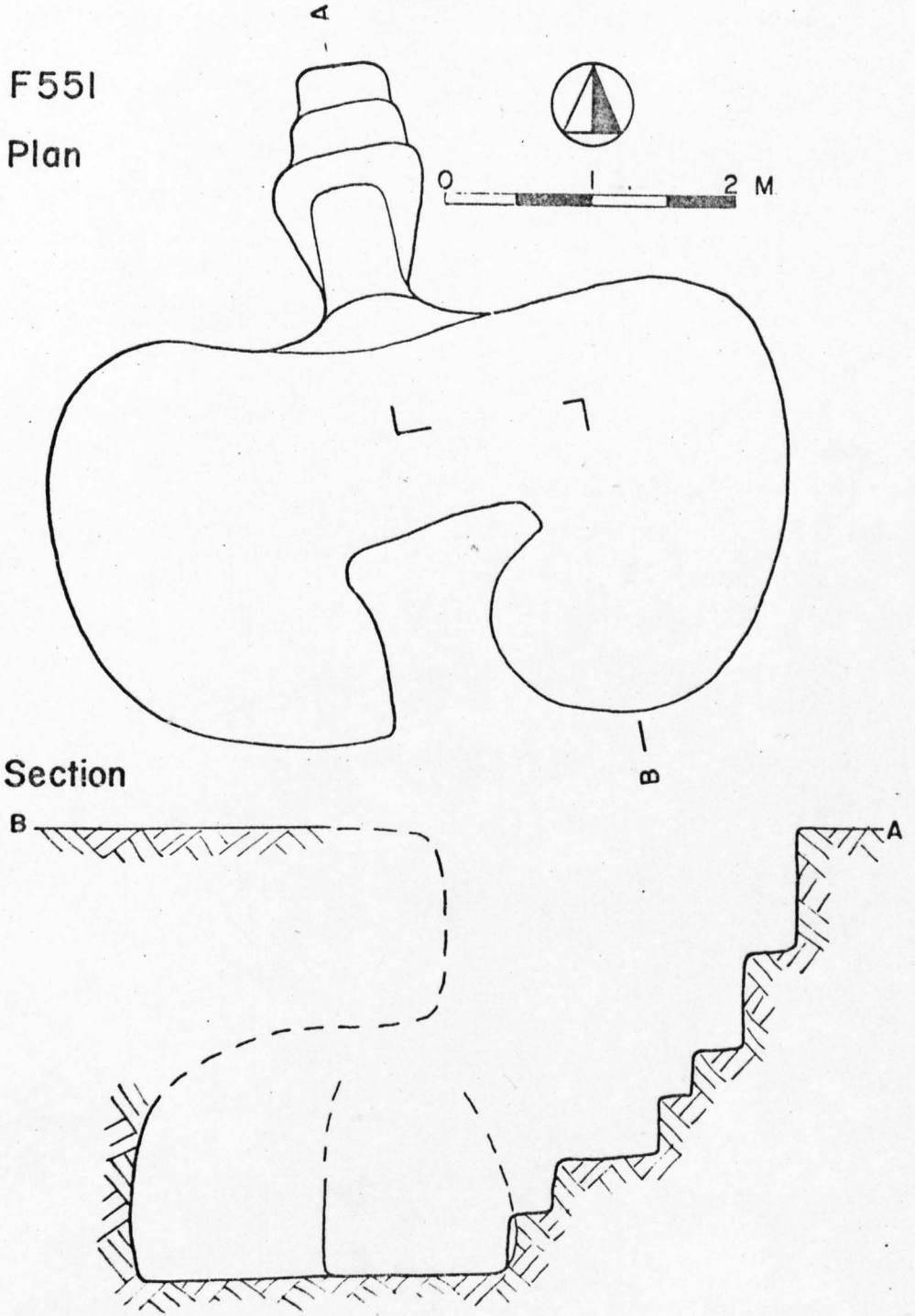
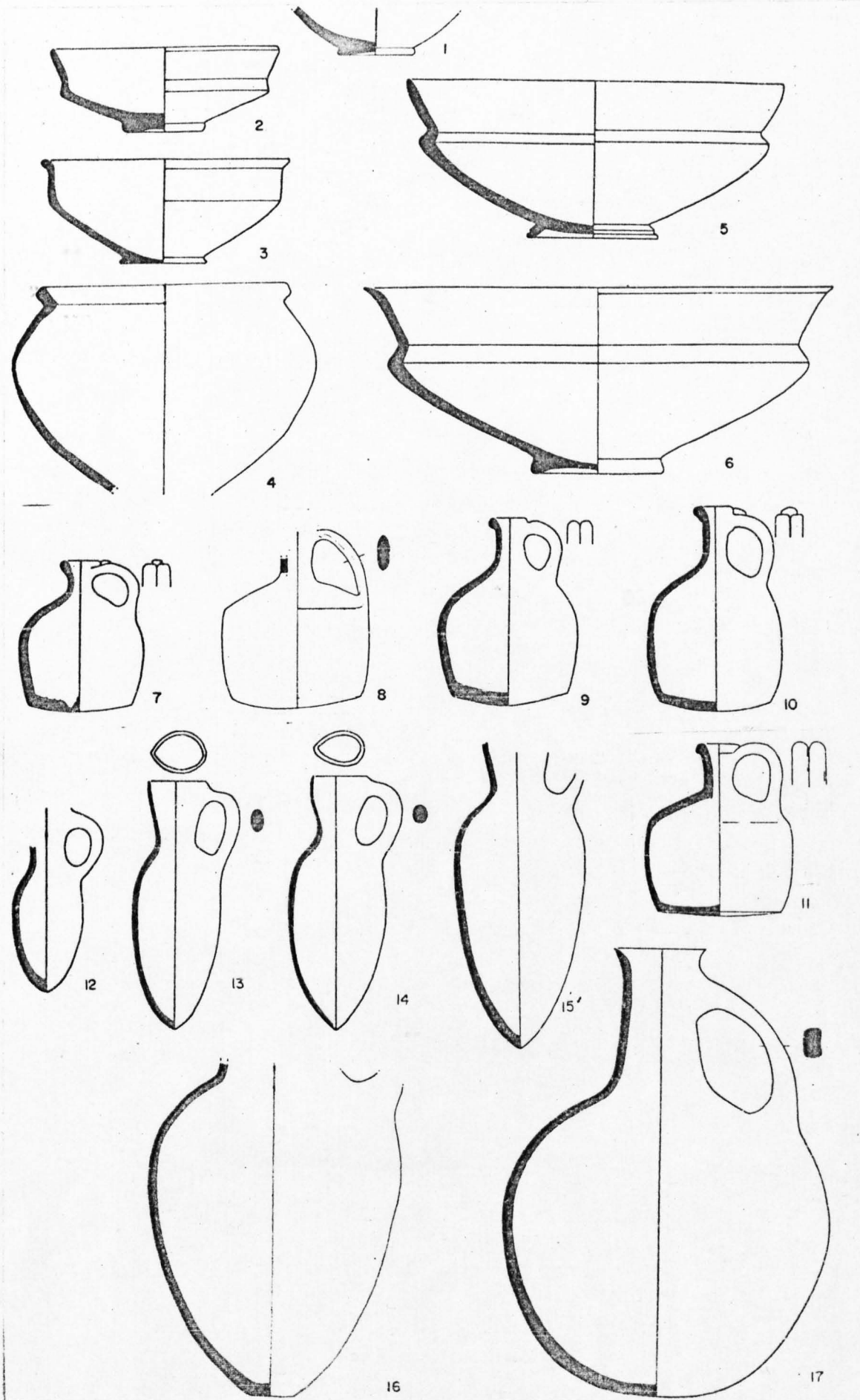

FIG. 24



1/4

FIG. 25



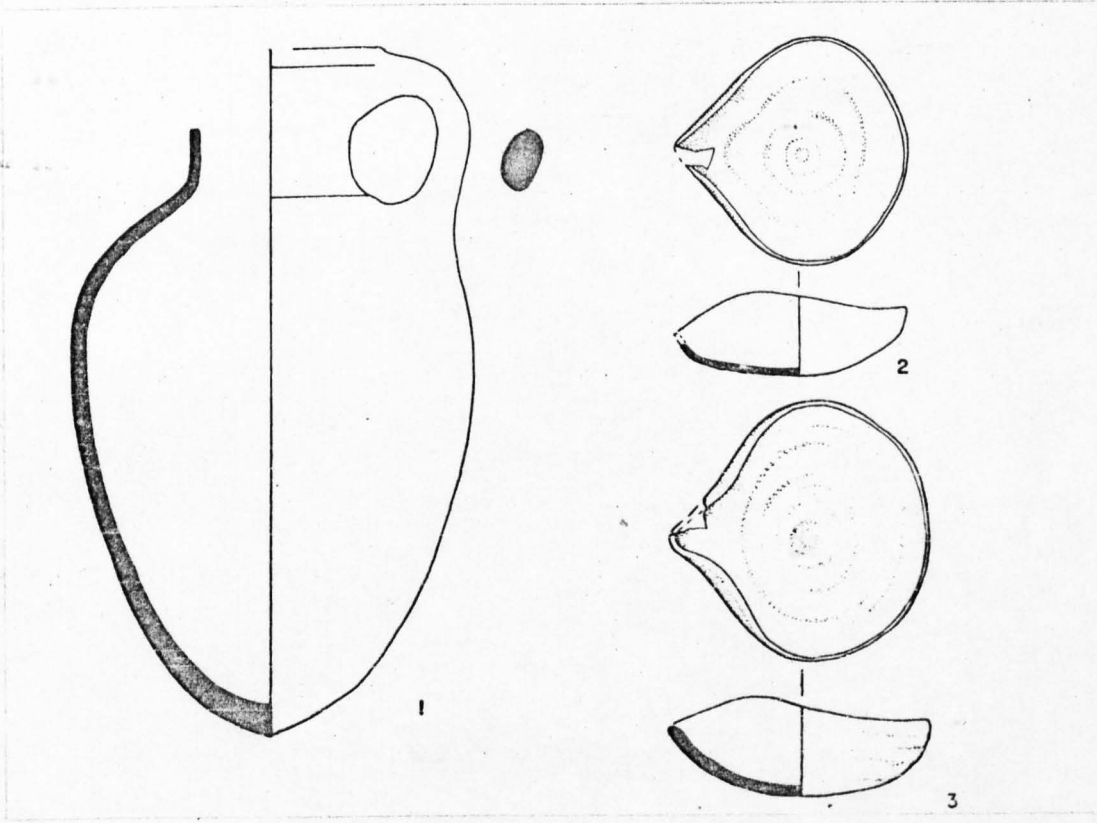

1/4

FIG. 26

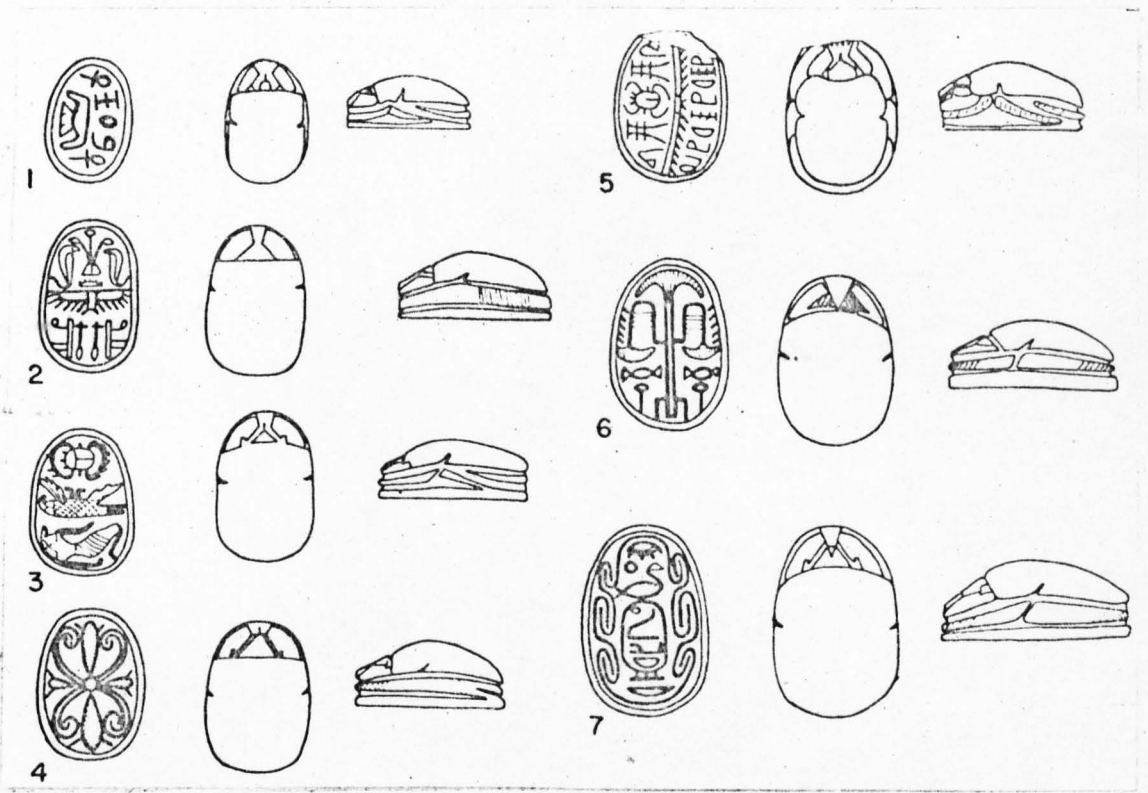

1/1

FIG. 27A

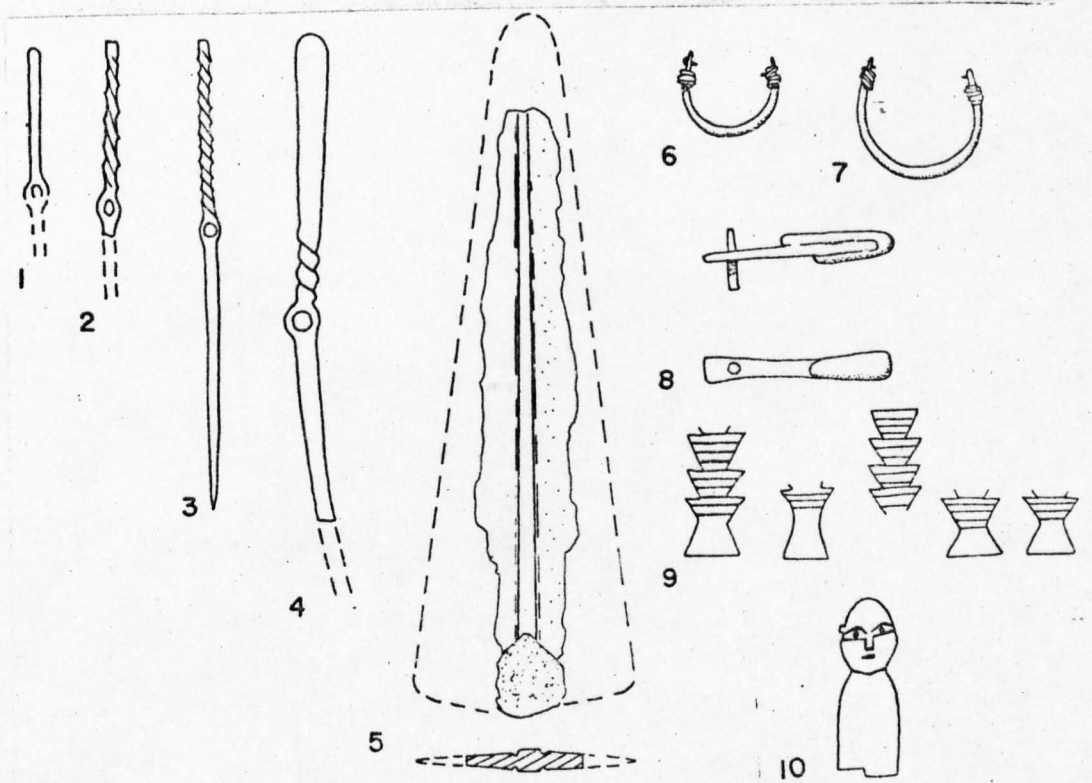

1/2

FIG. 27B

F554  
Plan

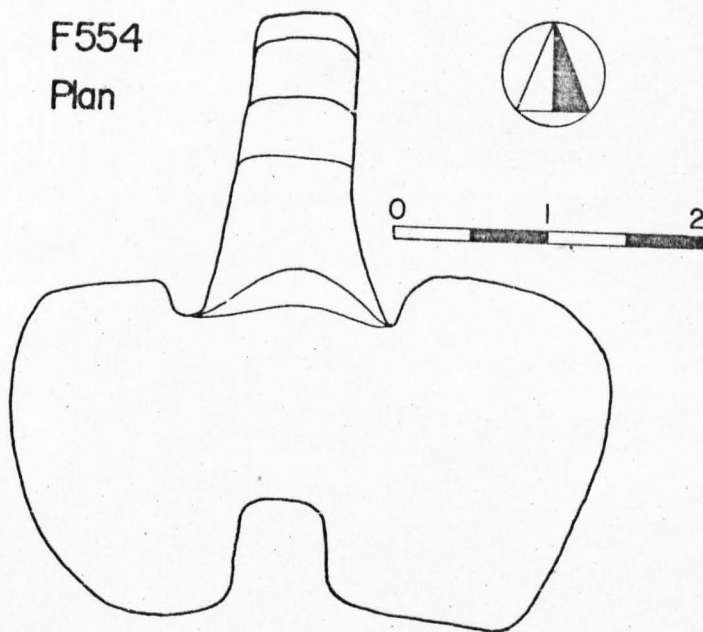
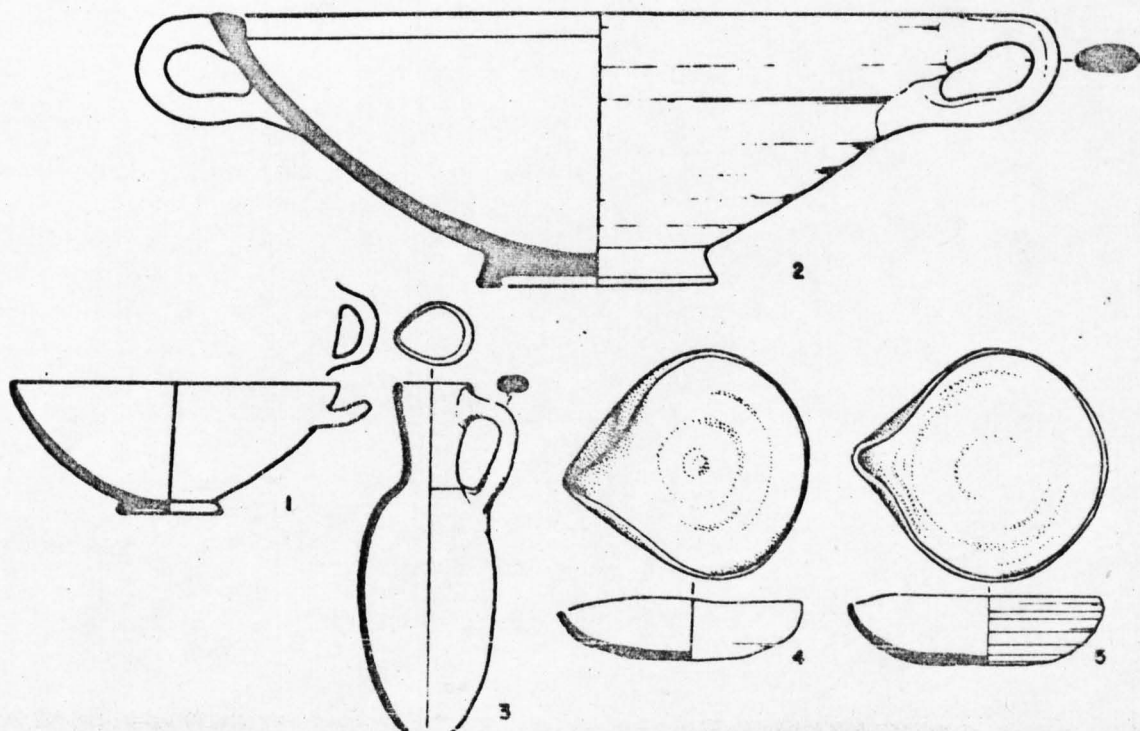
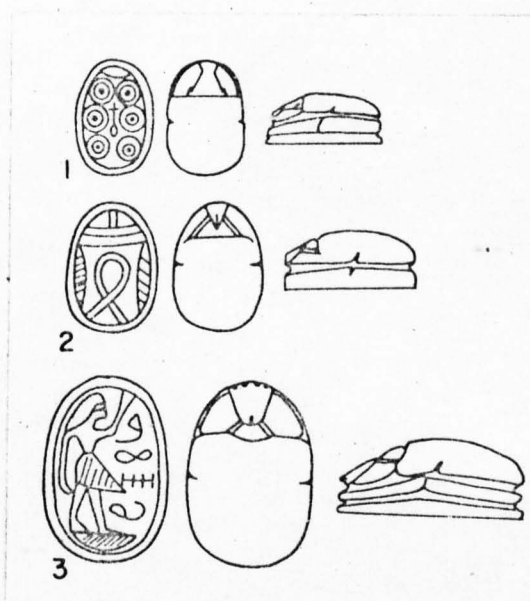

FIG.28A



1/4

FIG.28B



1/1

FIG. 29A

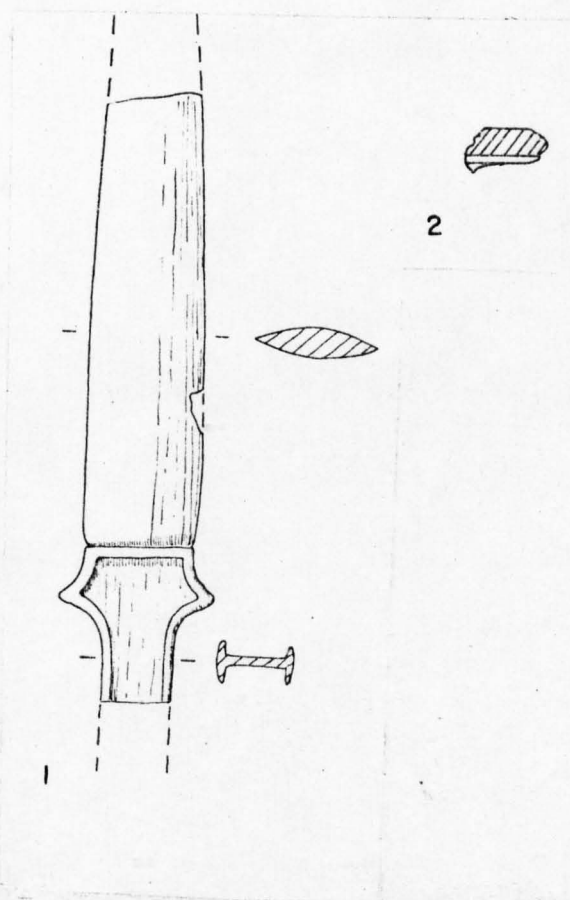

1/2

FIG. 29B

F555  
Plan

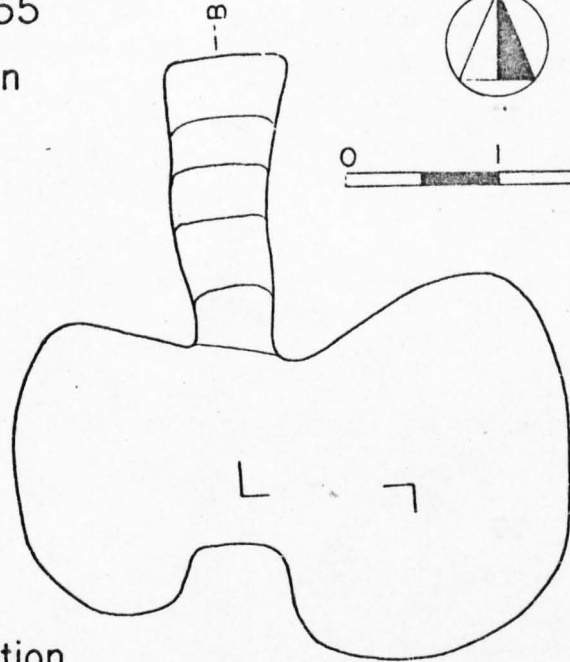

Section

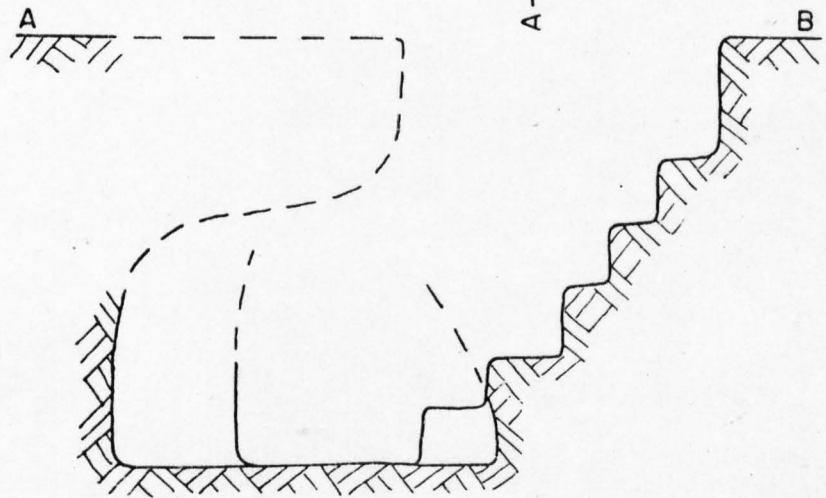
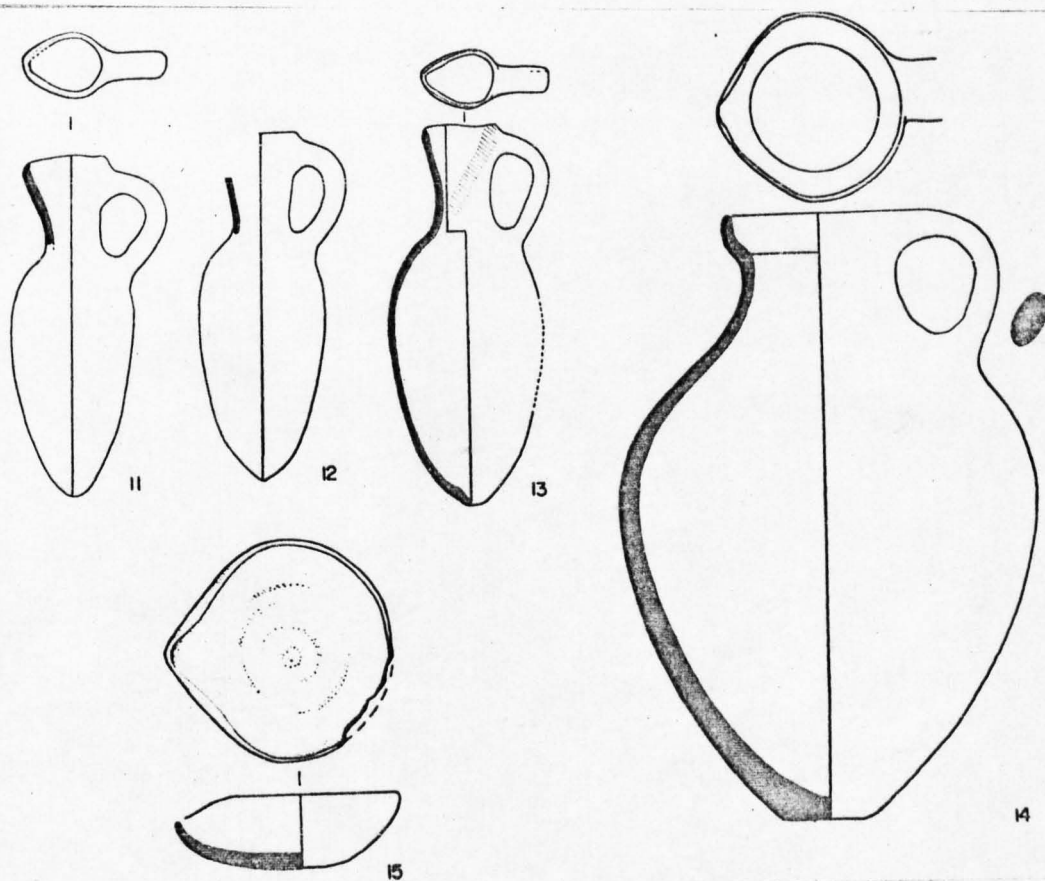
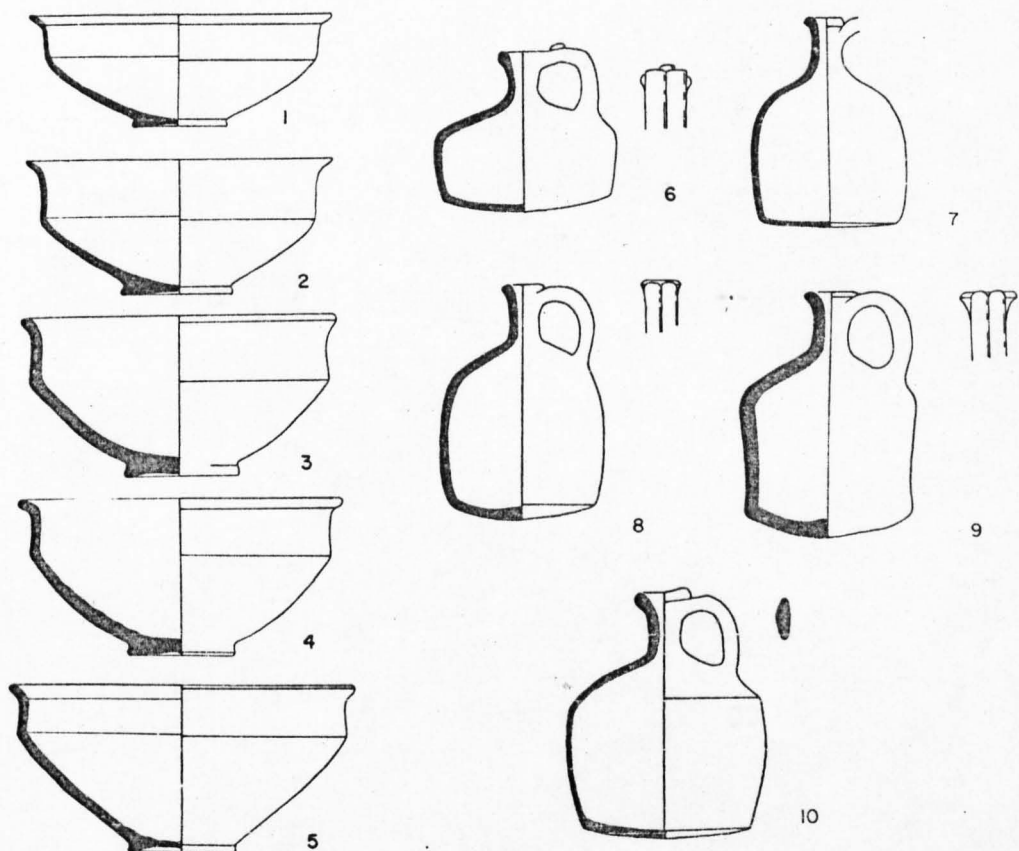

FIG. 30





1/4

FIG. 31

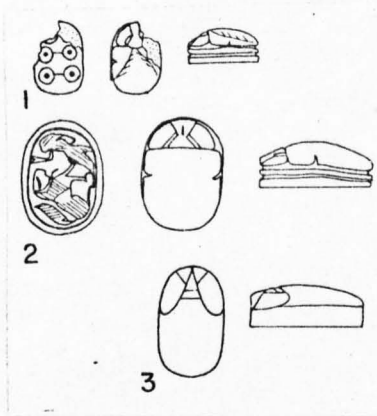

1/1  
FIG. 32A

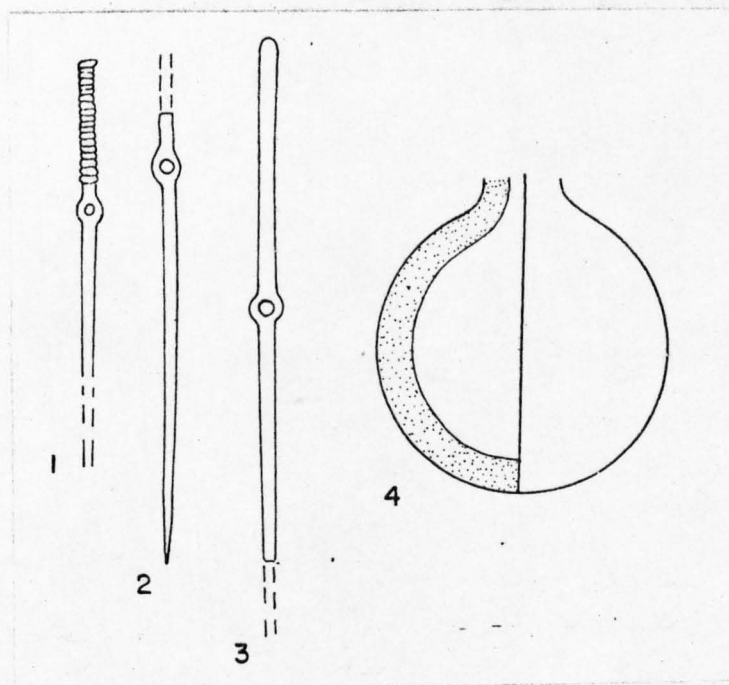

1/2

FIG. 32B

F556

Plan

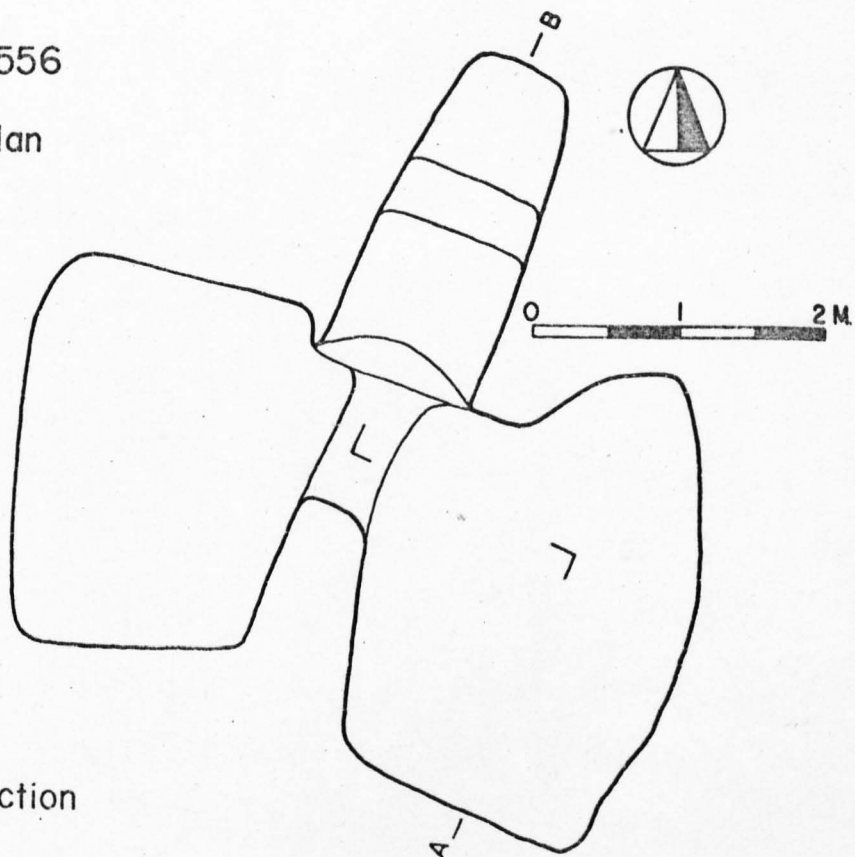

Section

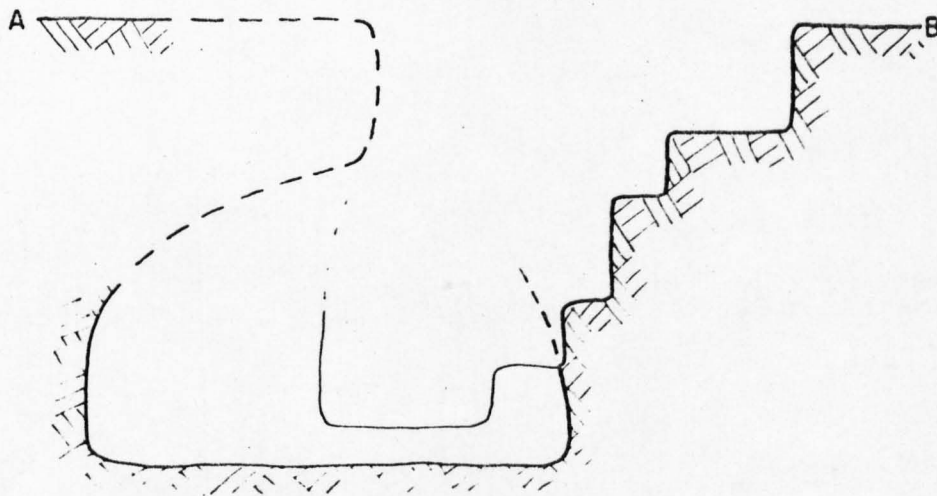
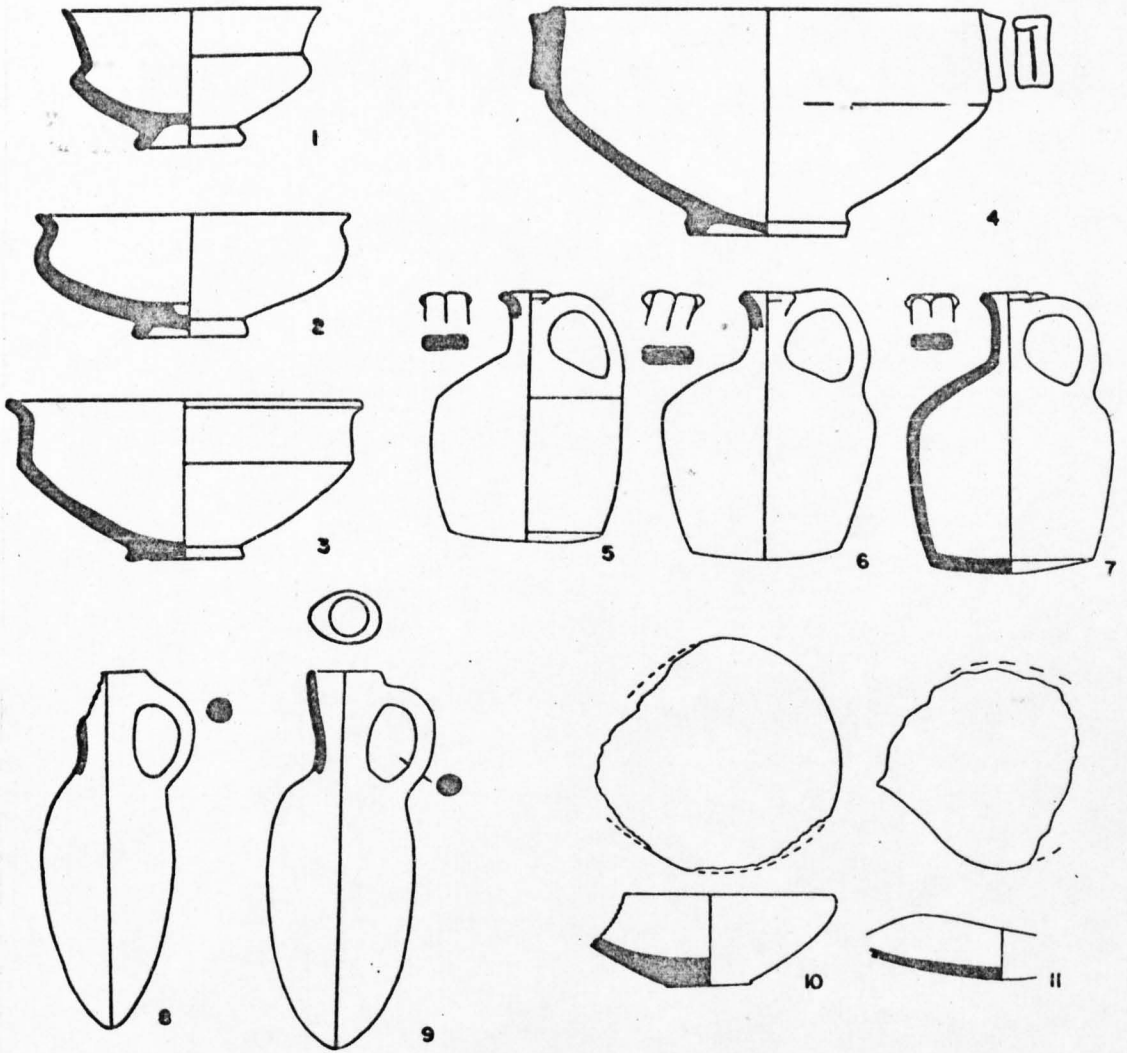

FIG. 33





1/4

FIG. 34

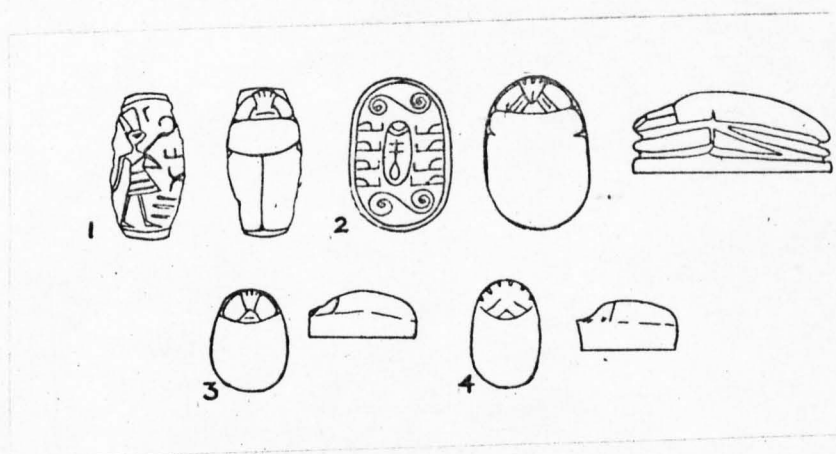

1/1

FIG. 35A

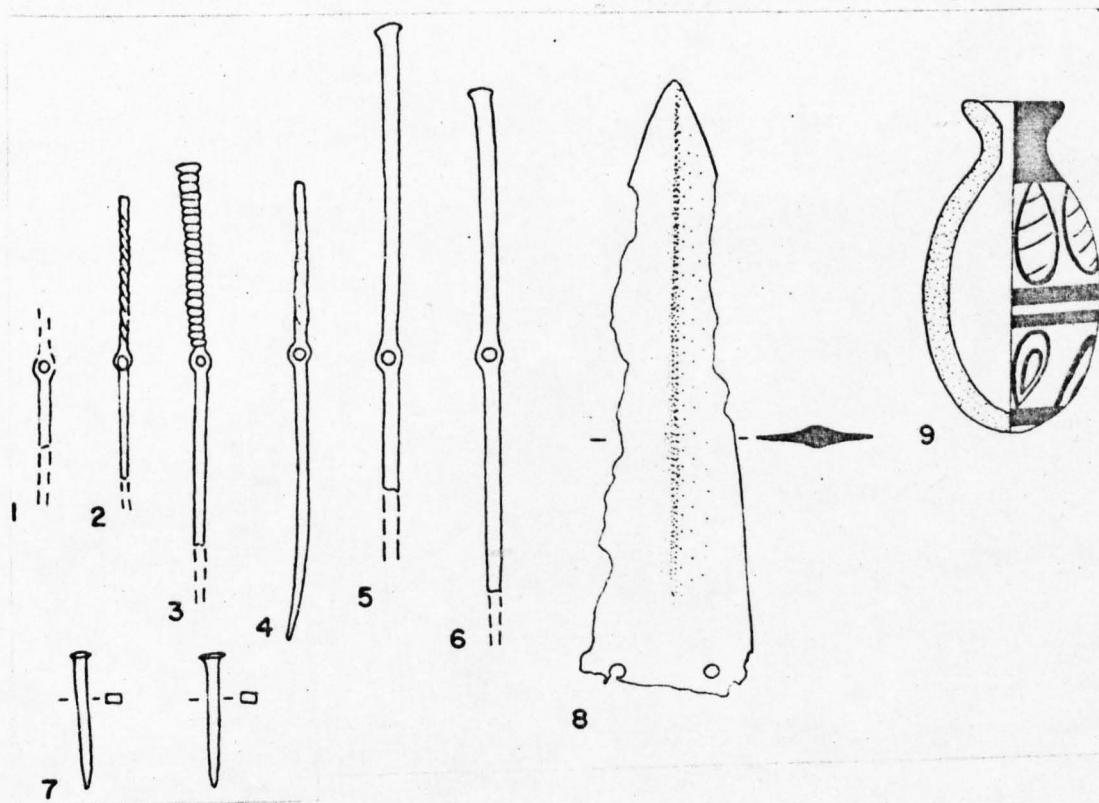

1/2

FIG. 35B

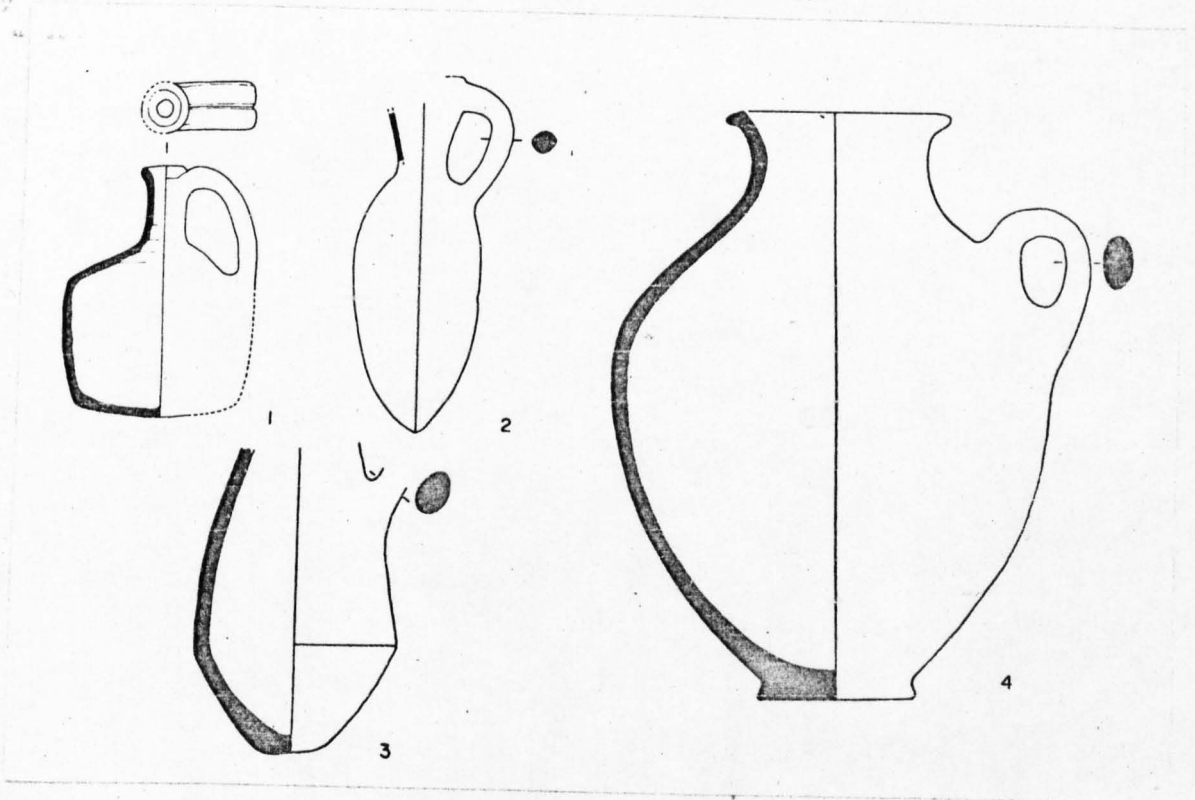

1/4

FIG. 36

F 558

Plan

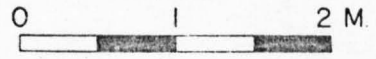
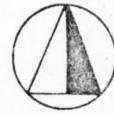
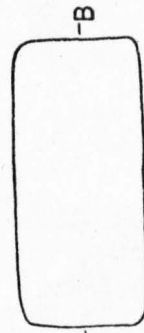

Section



FIG. 37A

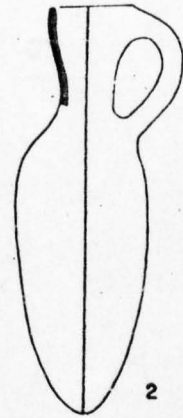
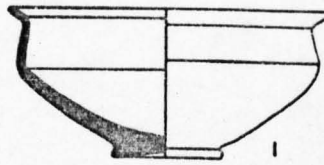

1/4 FIG. 37B

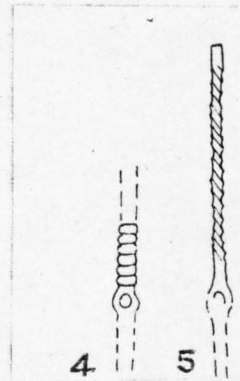
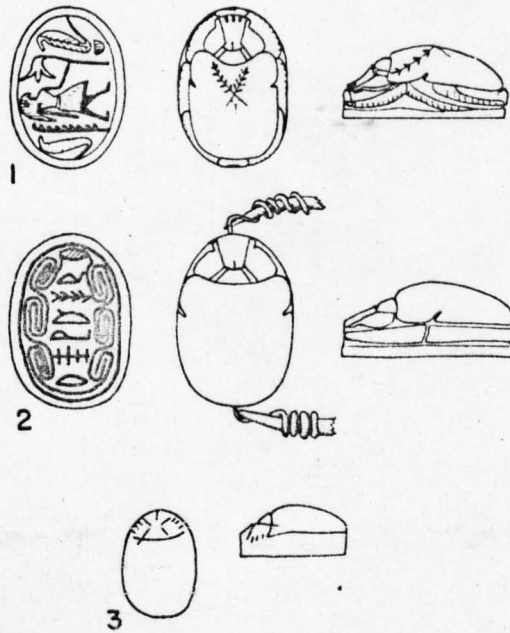

1/2

1/1

FIG. 37C

F559

Plan

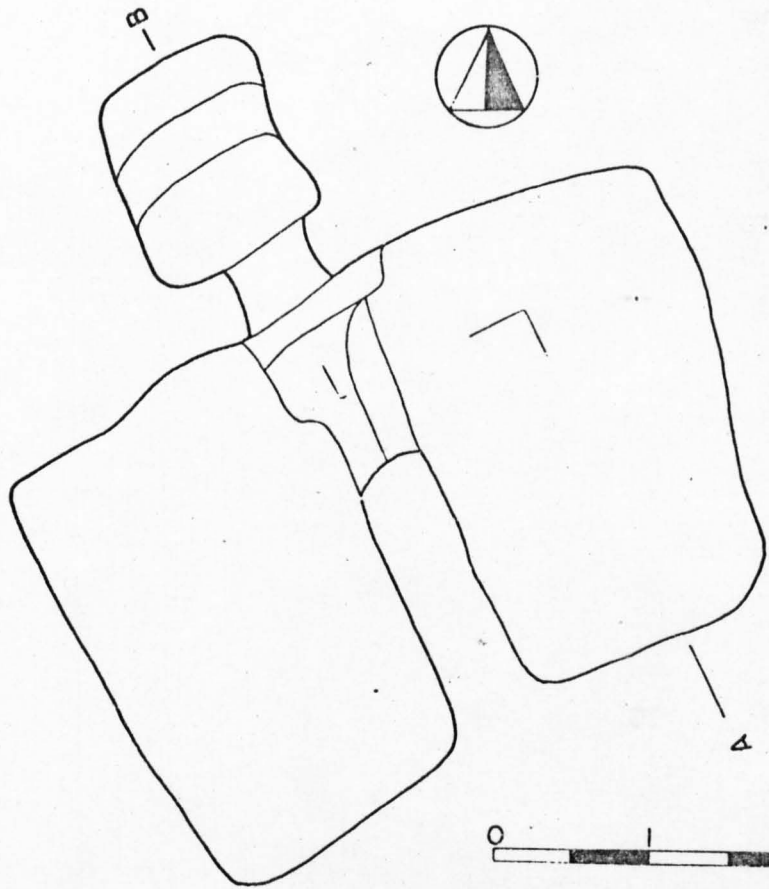

Section

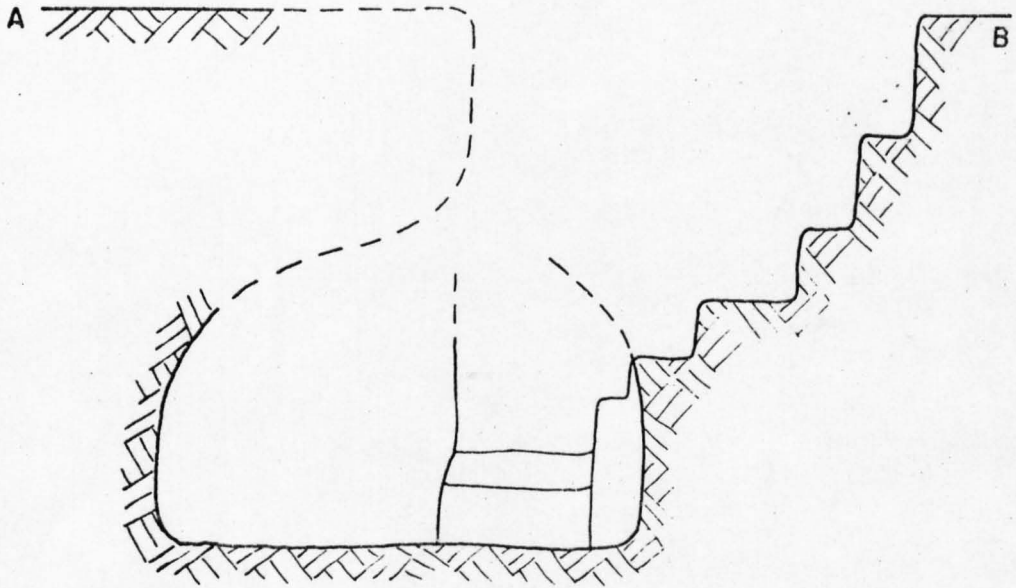
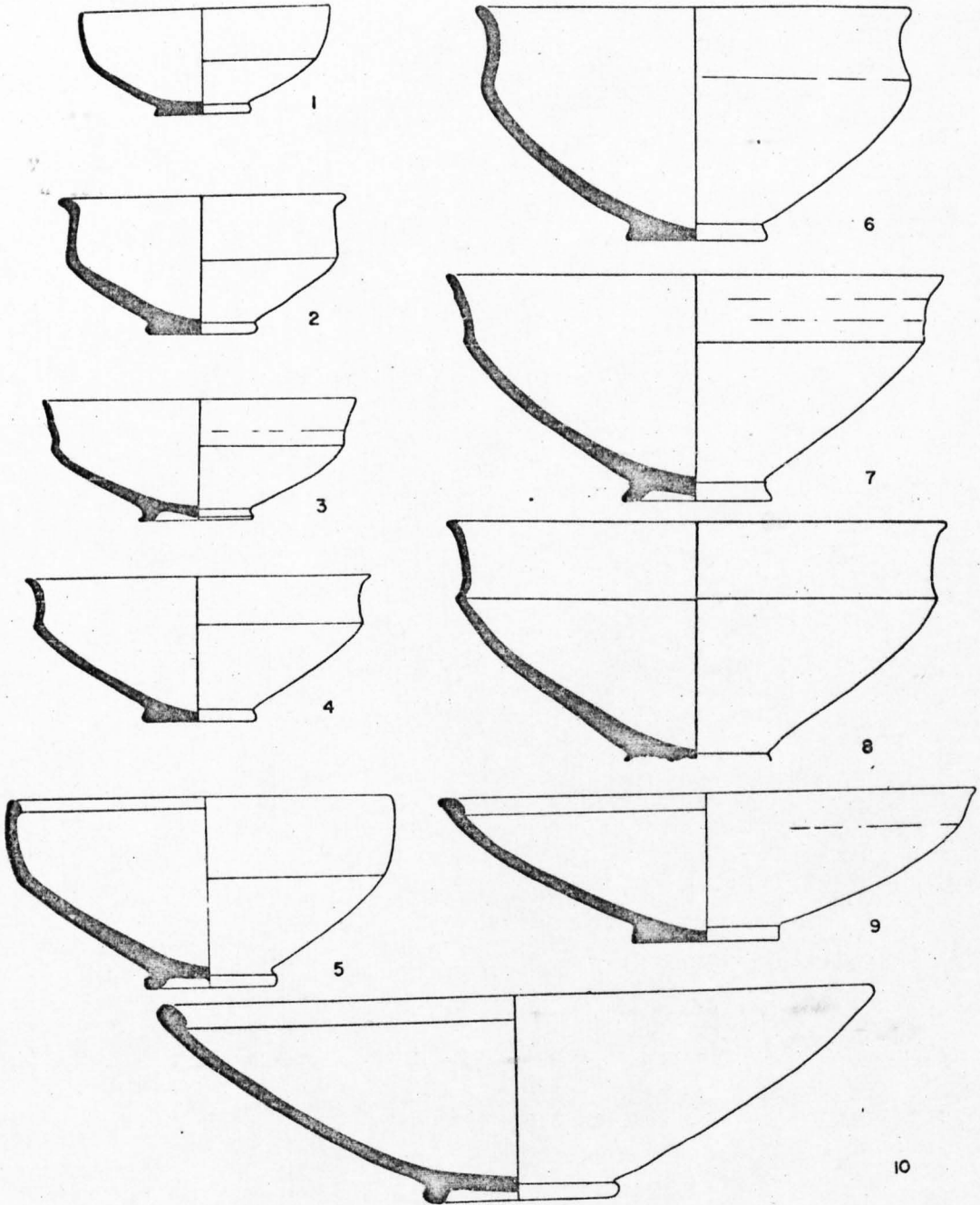

FIG. 38





1/4

FIG. 39

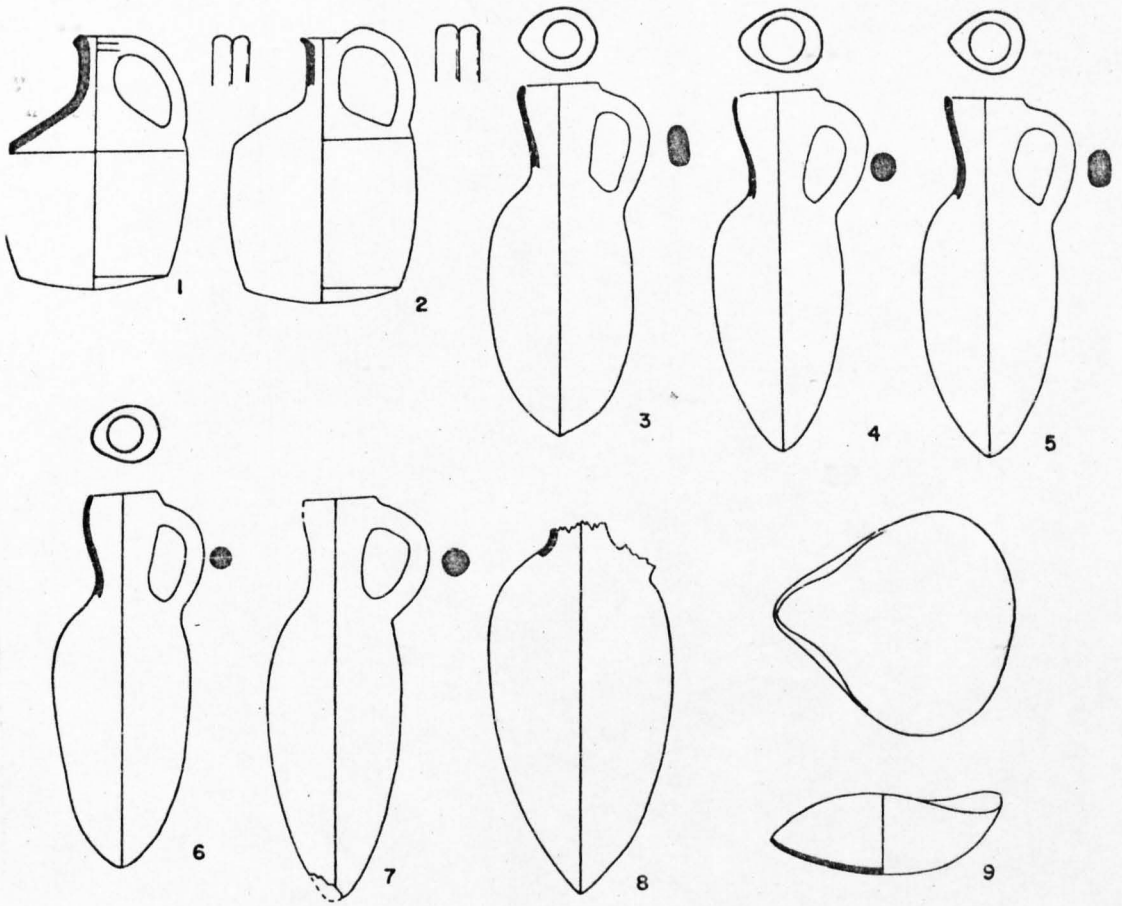

1/4

FIG.40

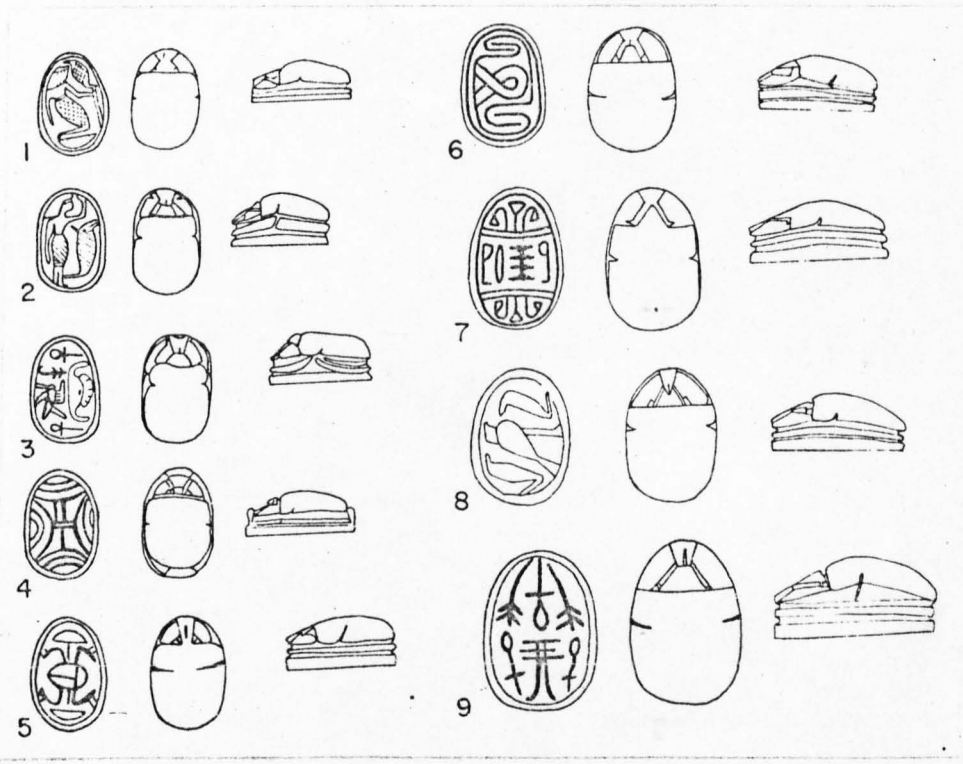

1/1

FIG. 41A

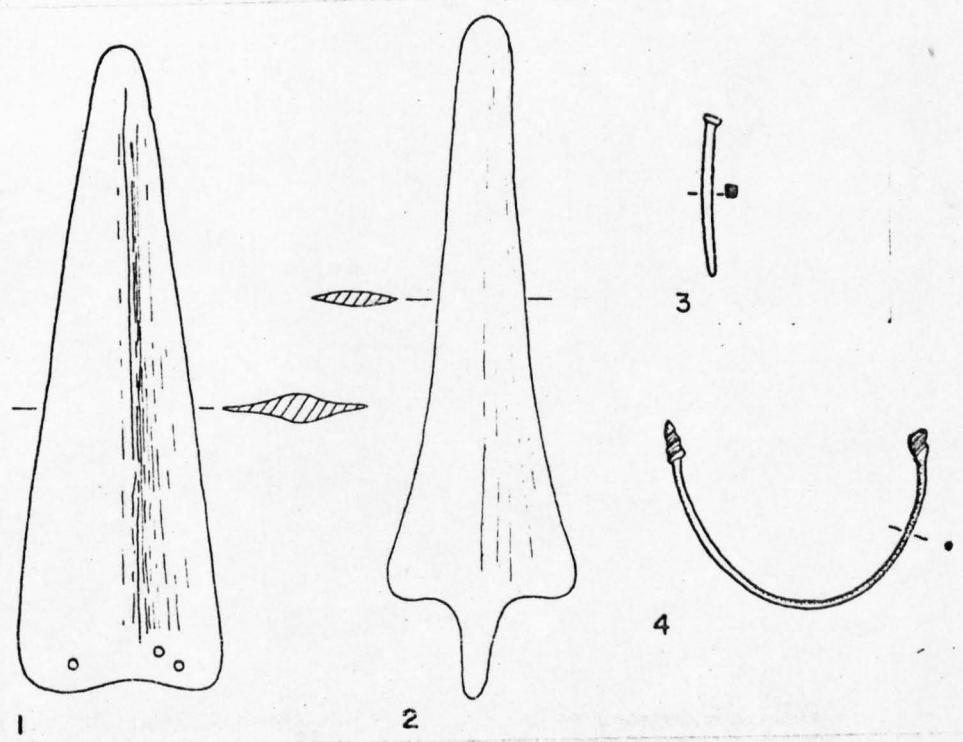

1/2

FIG. 41B



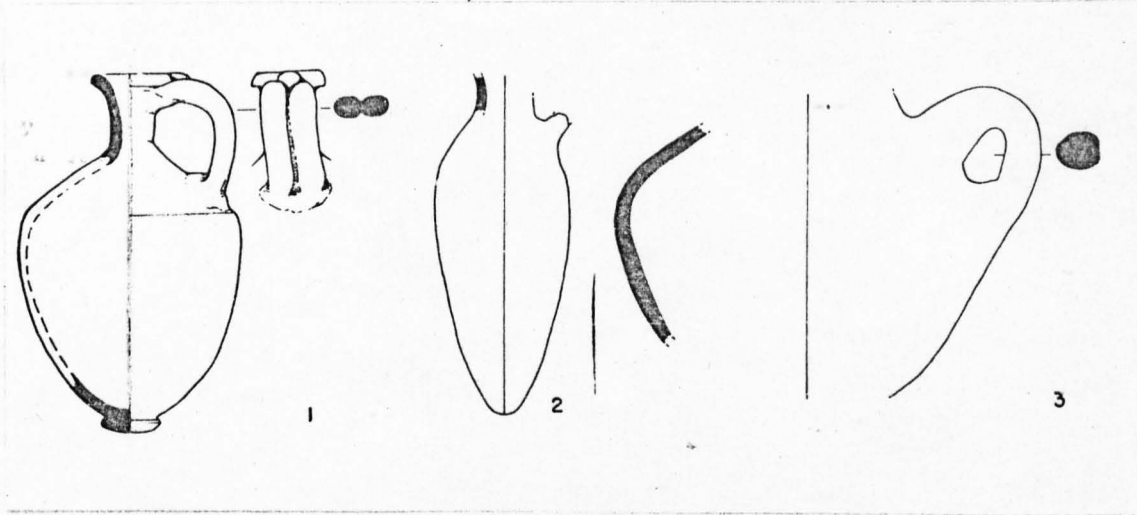
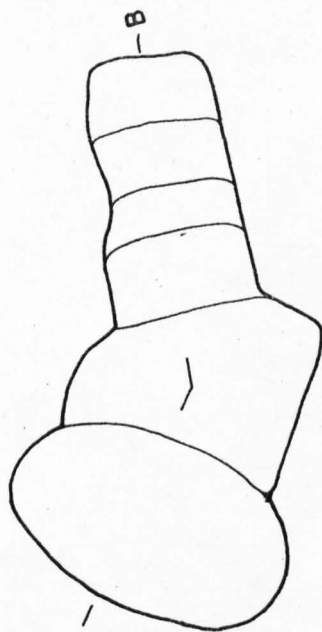

FIG. 42

F563  
Plan



Section

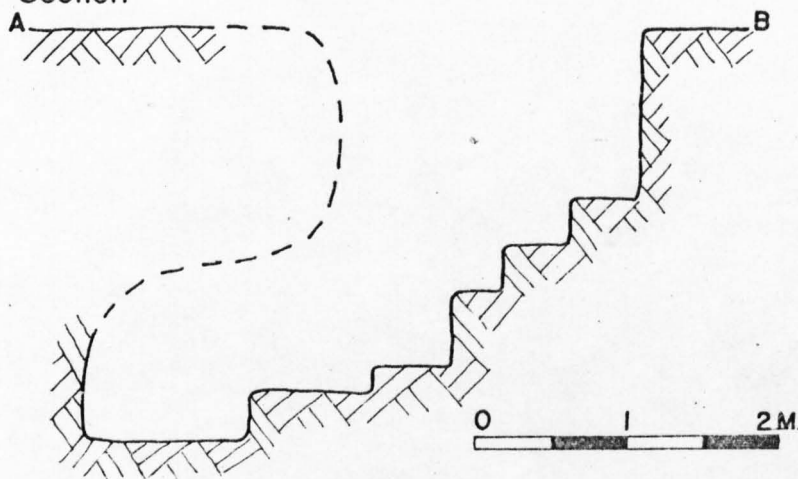
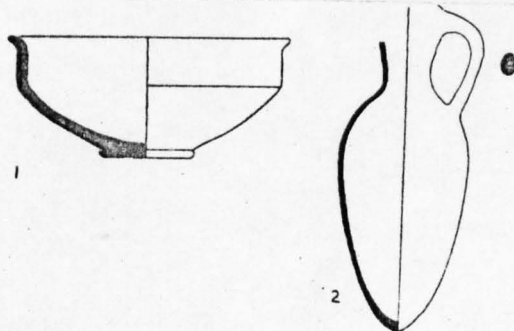
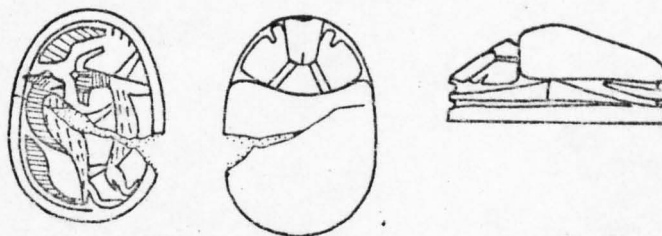

FIG. 43A



1/4

FIG. 43B



1/1

FIG. 43C

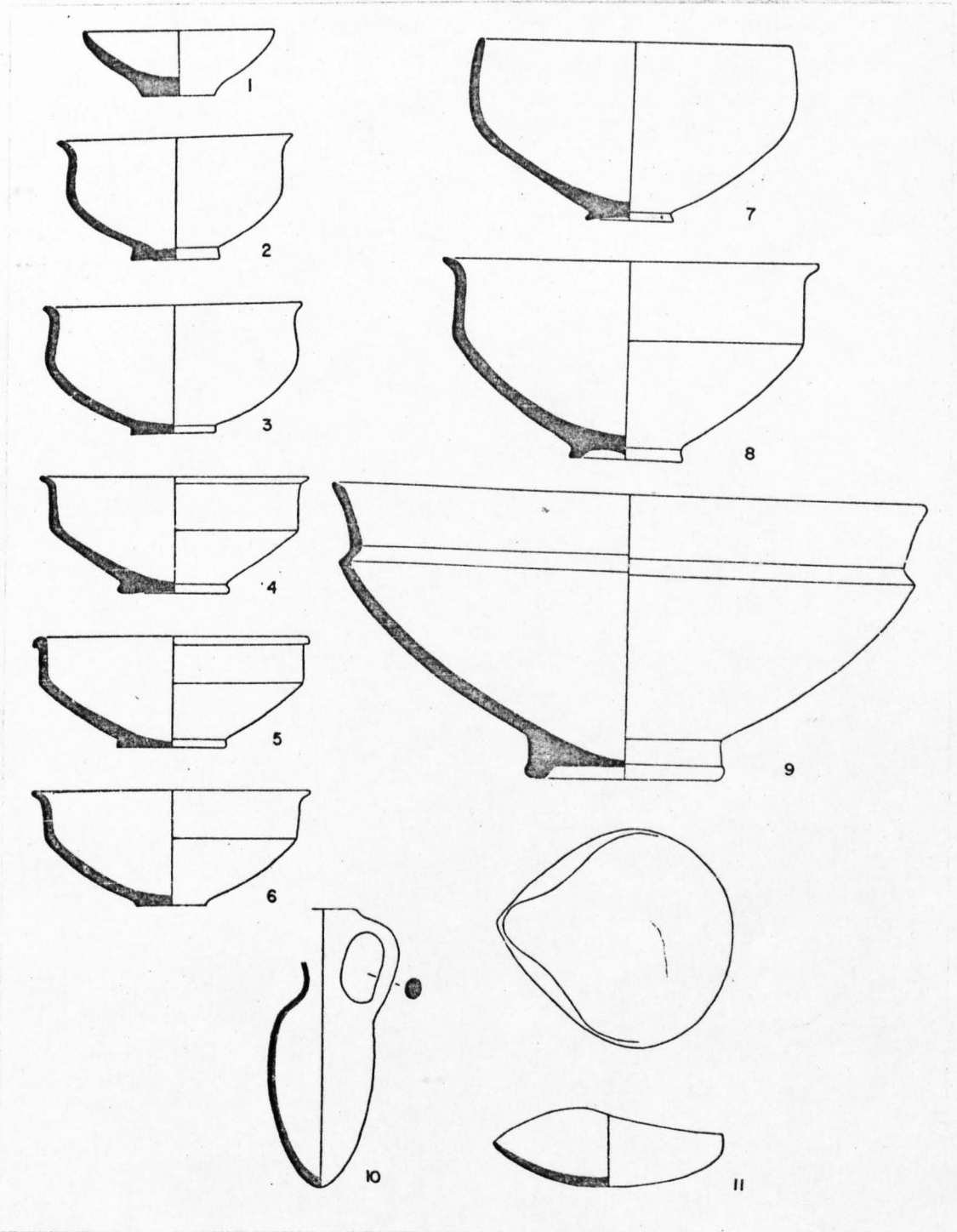

1/4

FIG. 44

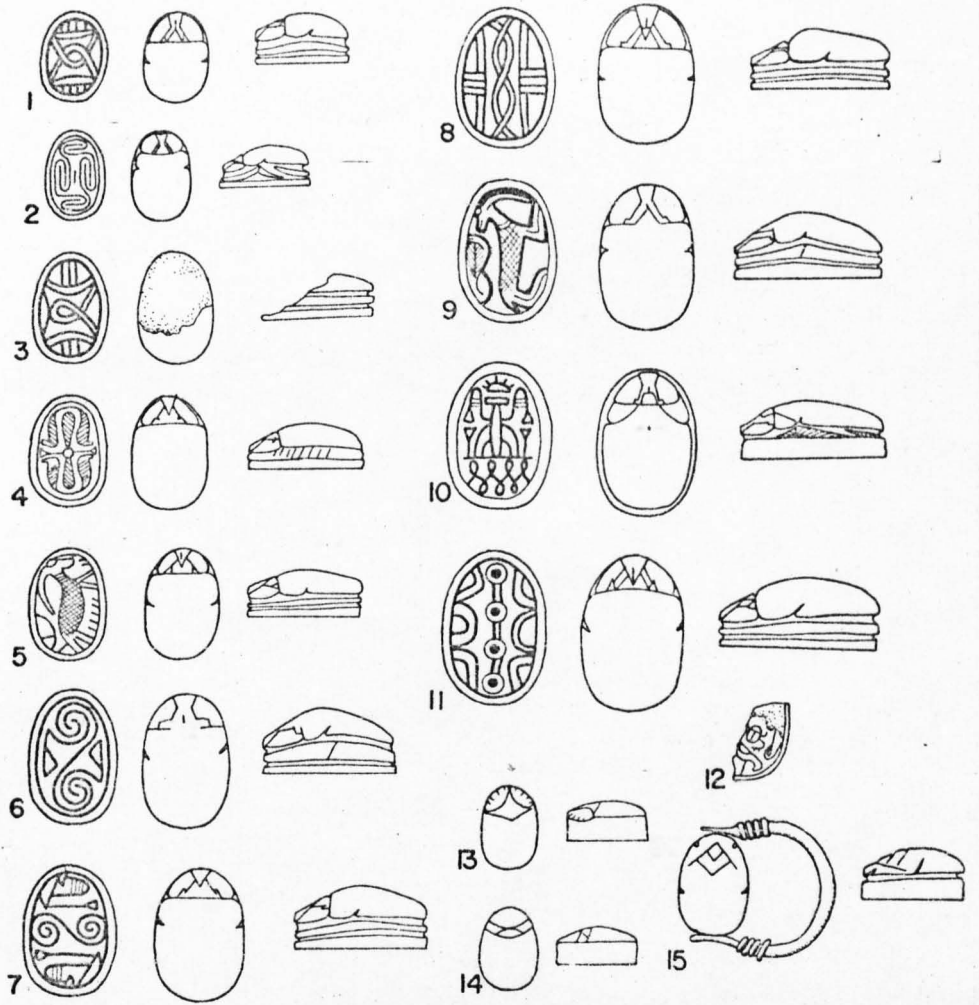

1/1

FIG. 45A

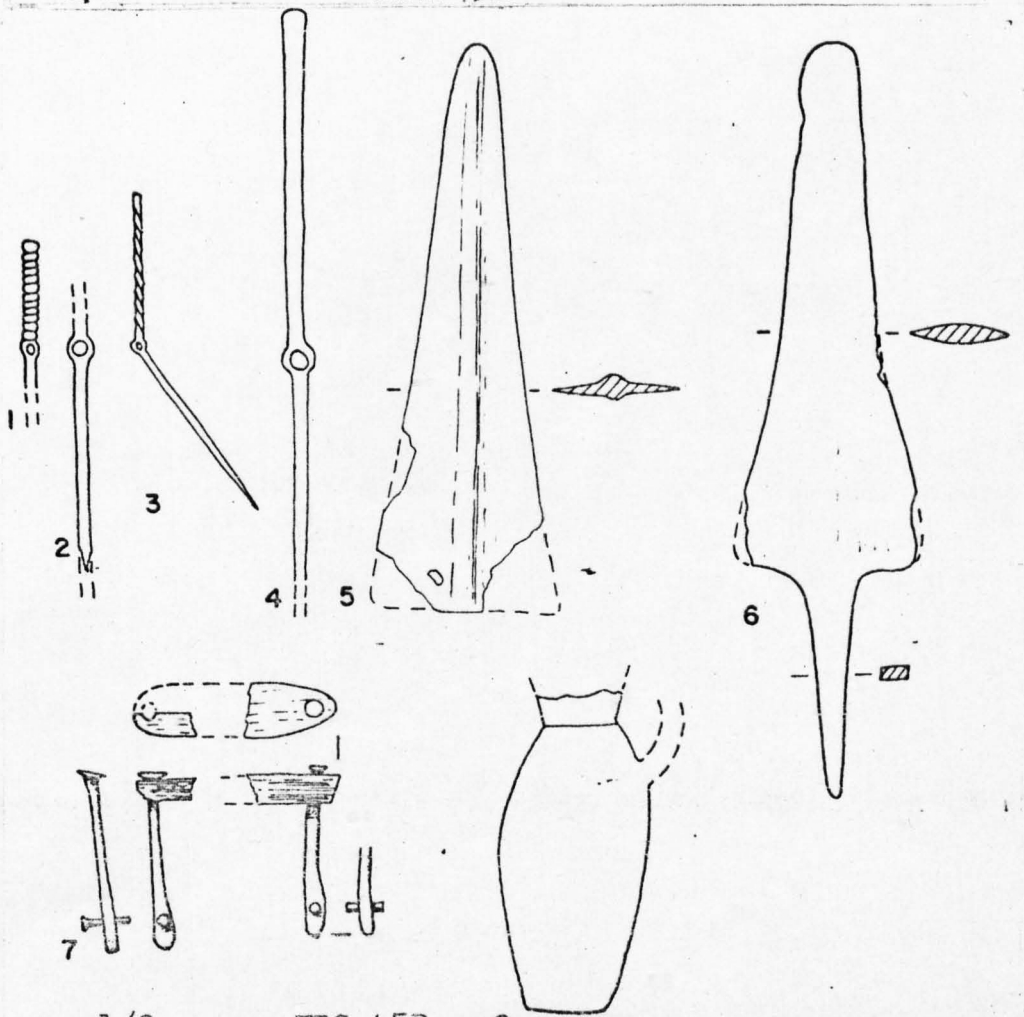

1/2

FIG. 45B

8

F565

Plan

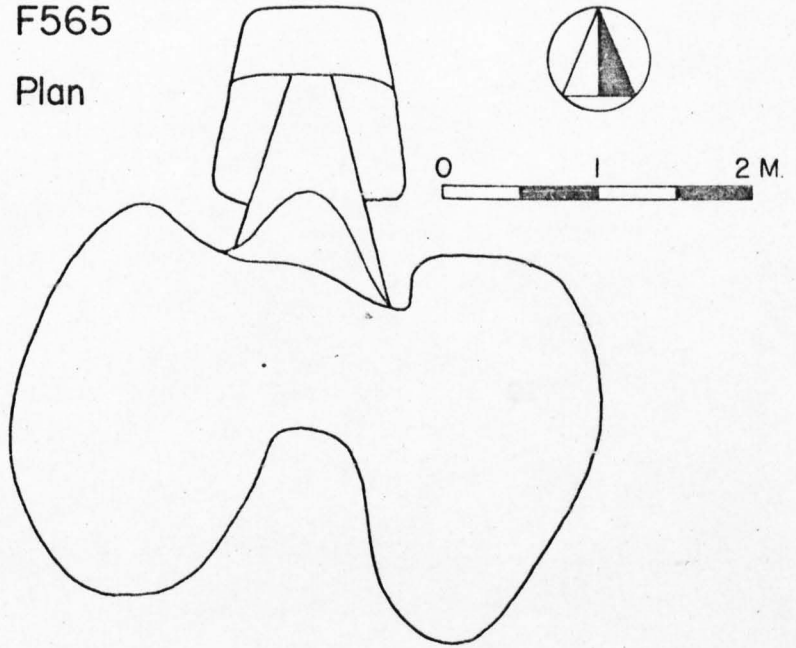

FIG. 46



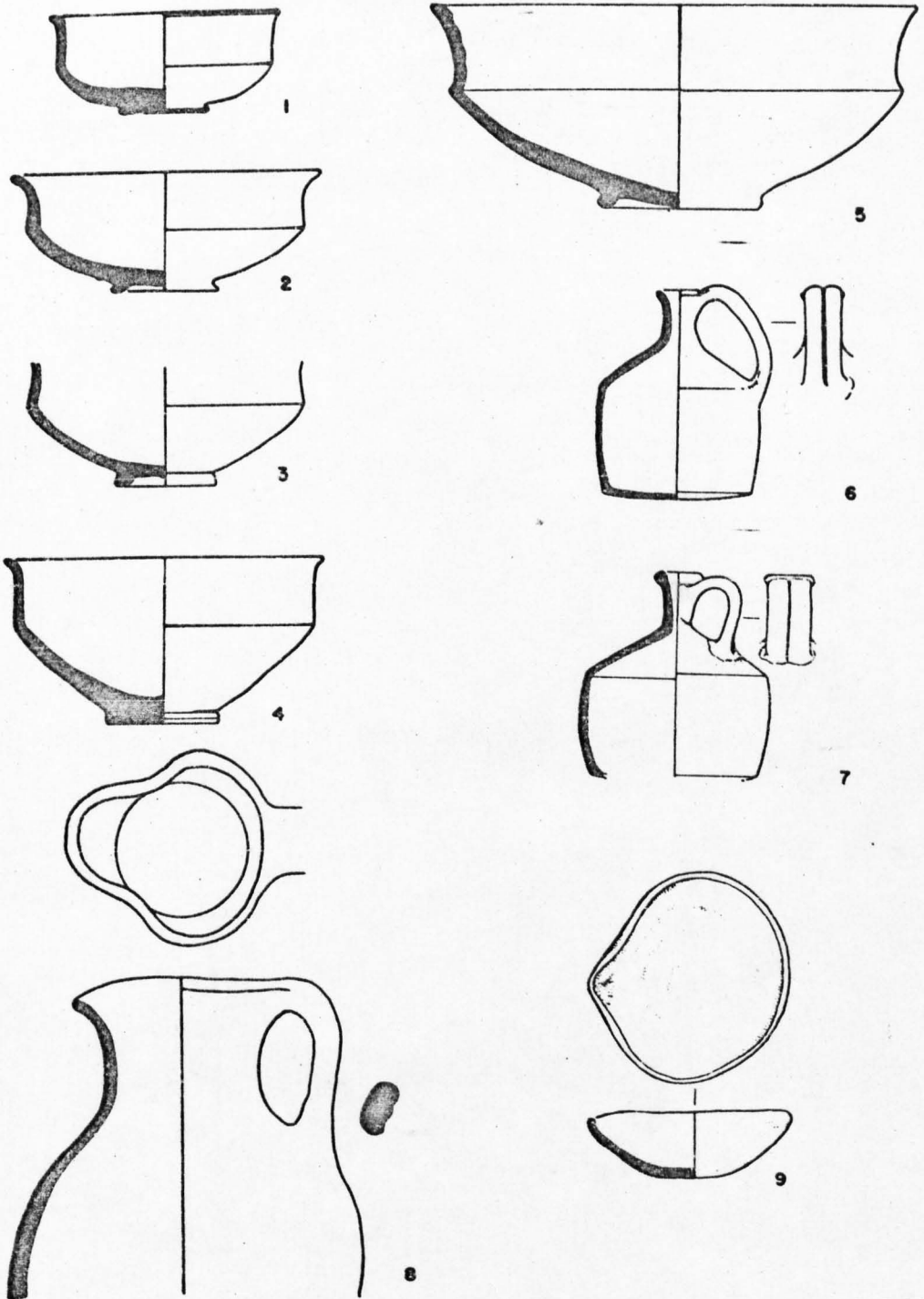
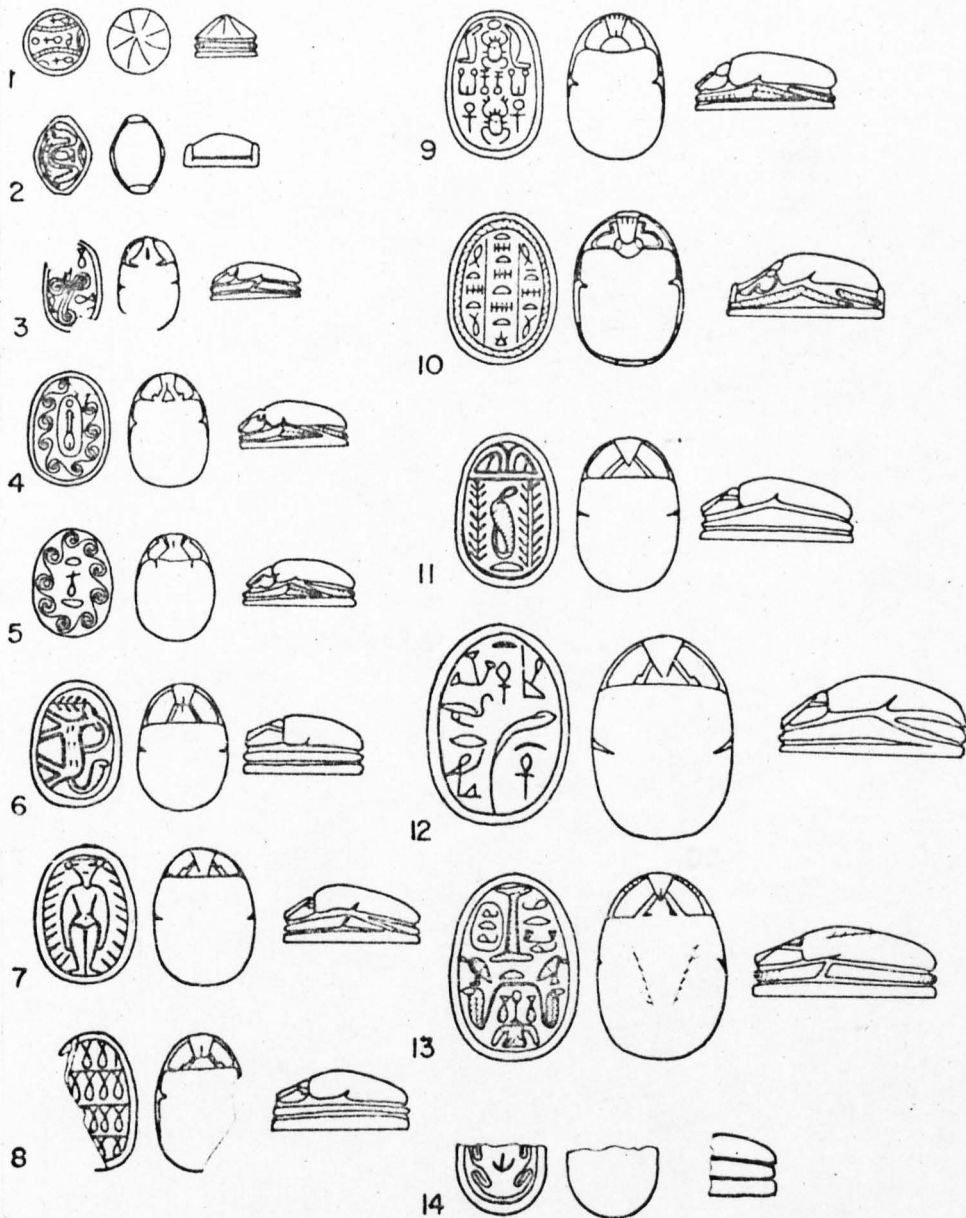
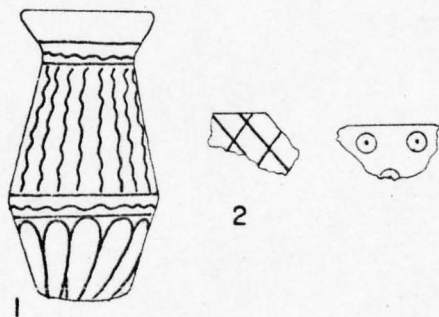

FIG. 47



1/1

FIG. 48A



1/2

FIG. 48B

F566

Plan

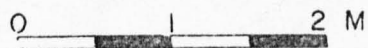
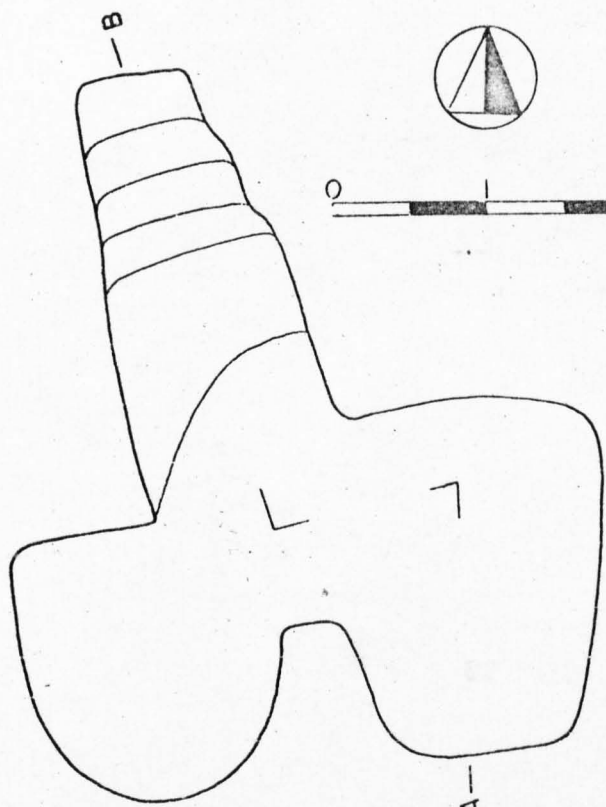

Section

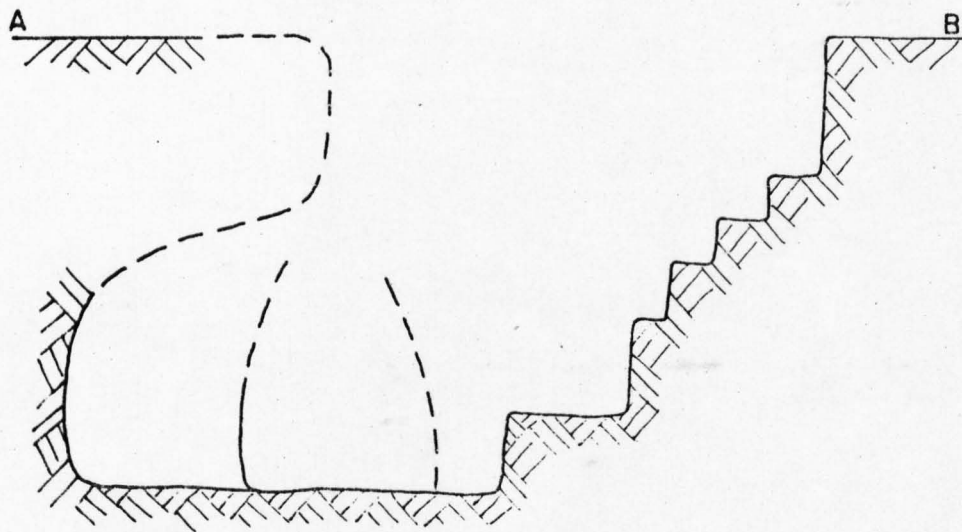
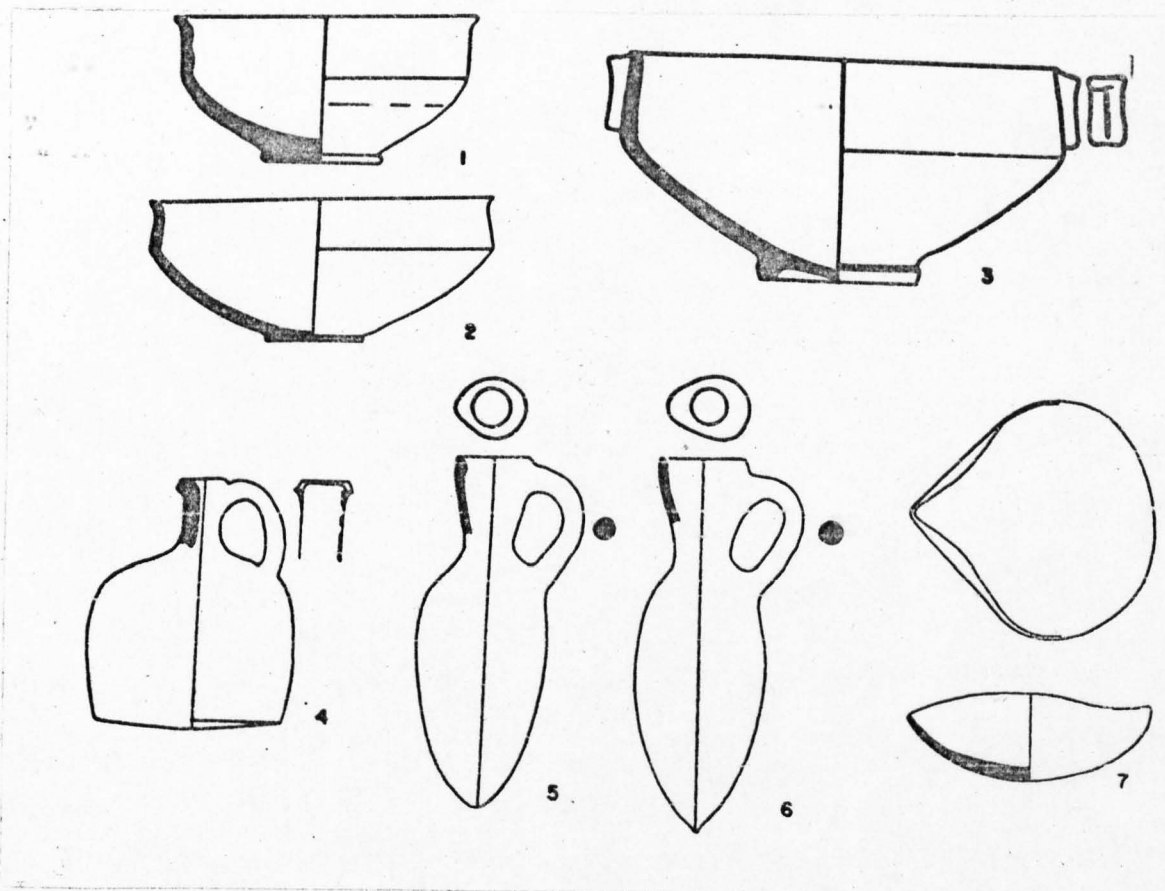

FIG. 49





1/4

FIG. 50

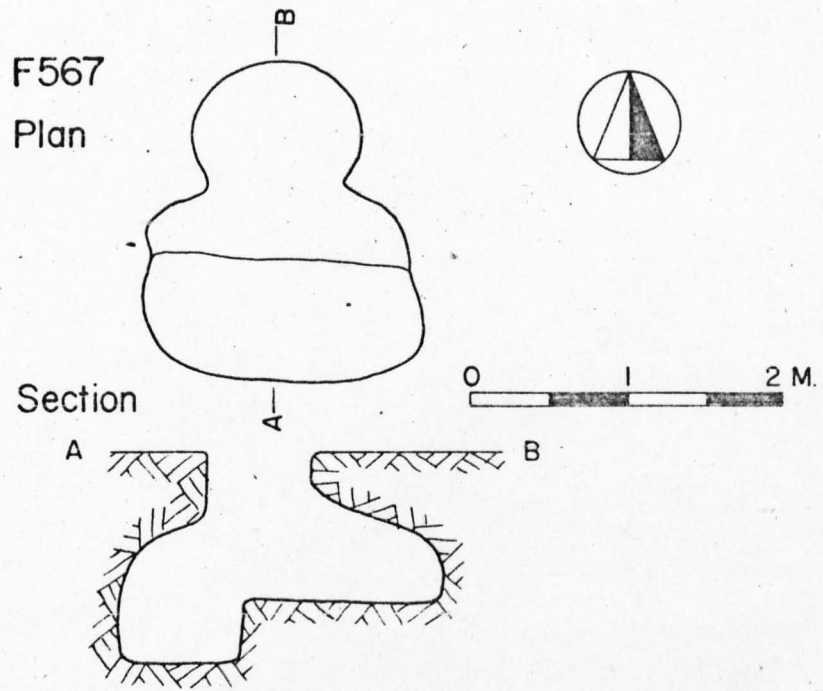
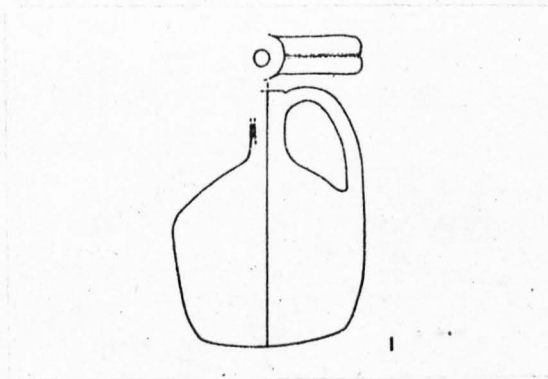
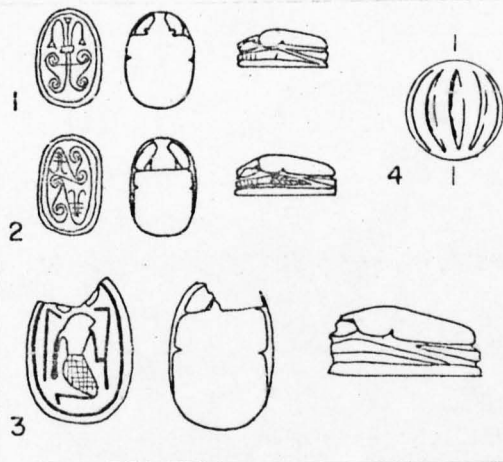

FIG. 51



1/4

FIG. 52A



1/1

FIG. 52B

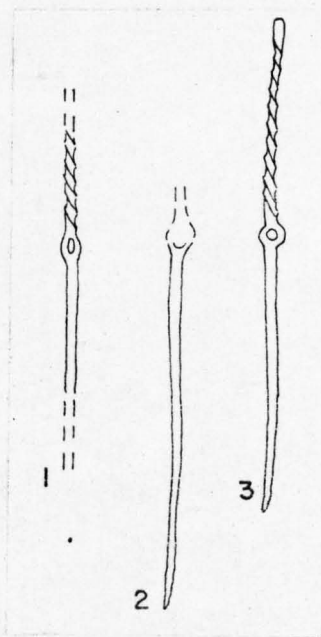

1/2

FIG. 52C

F569  
Plan

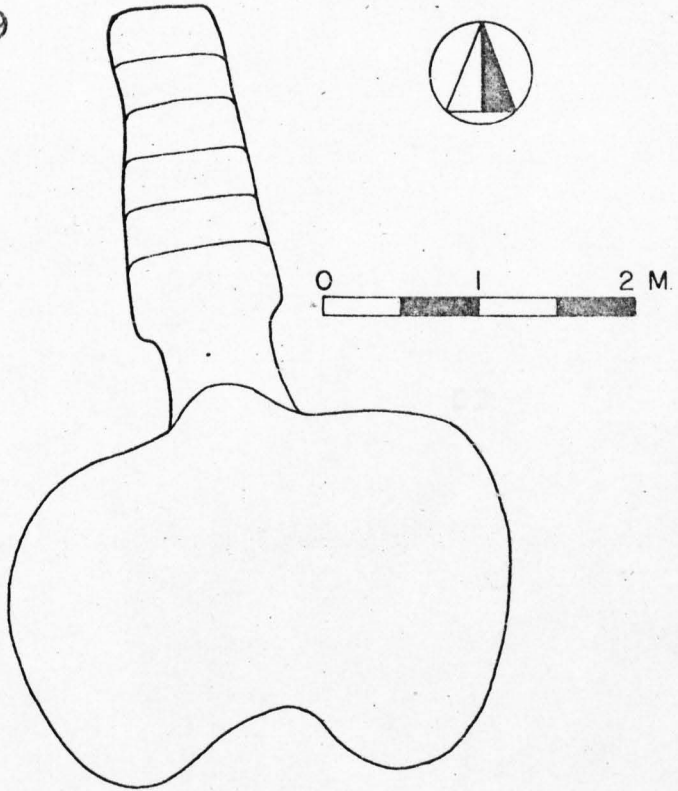
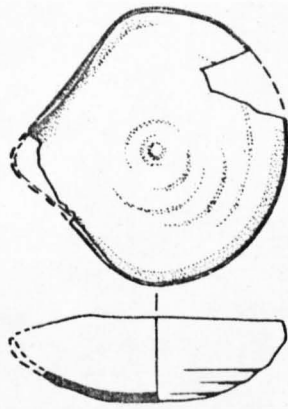
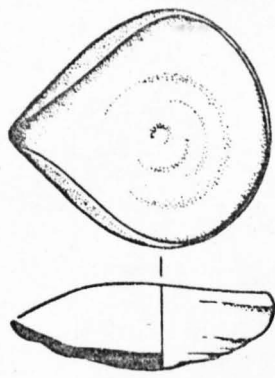
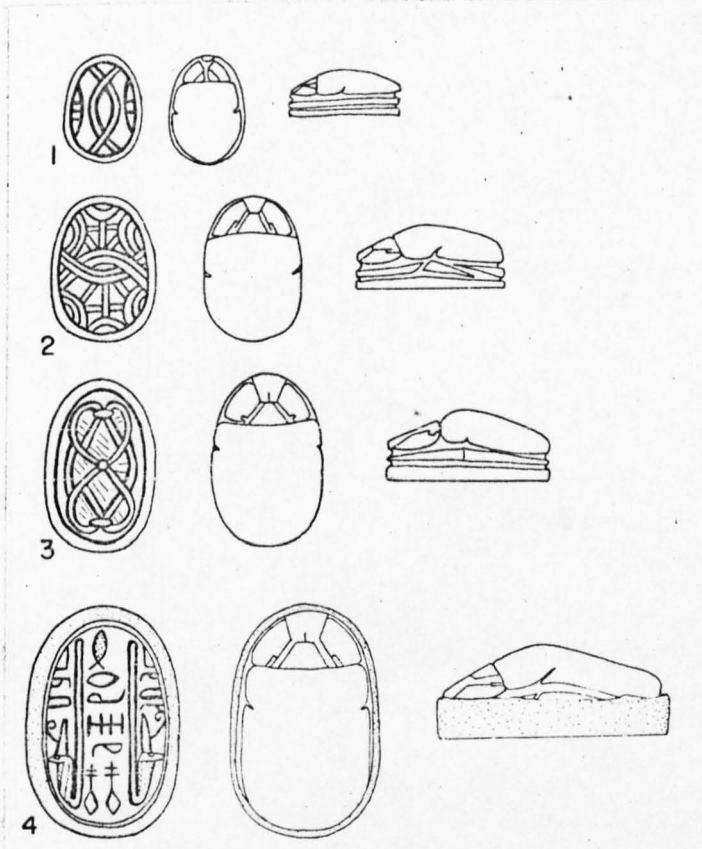

FIG. 53



1/4

FIG. 55A



1/1

FIG. 55B

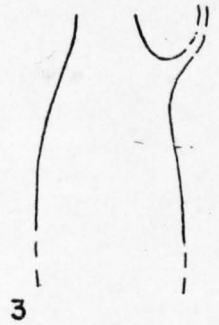
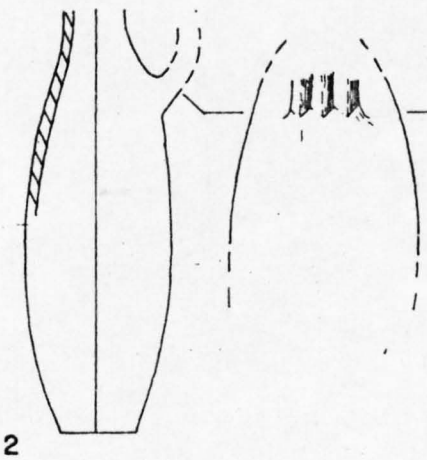
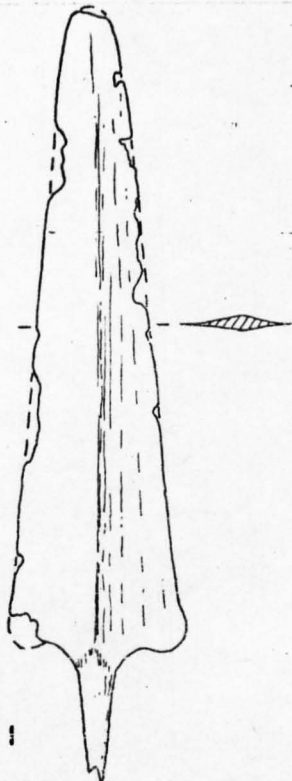

1/2

FIG. 55C



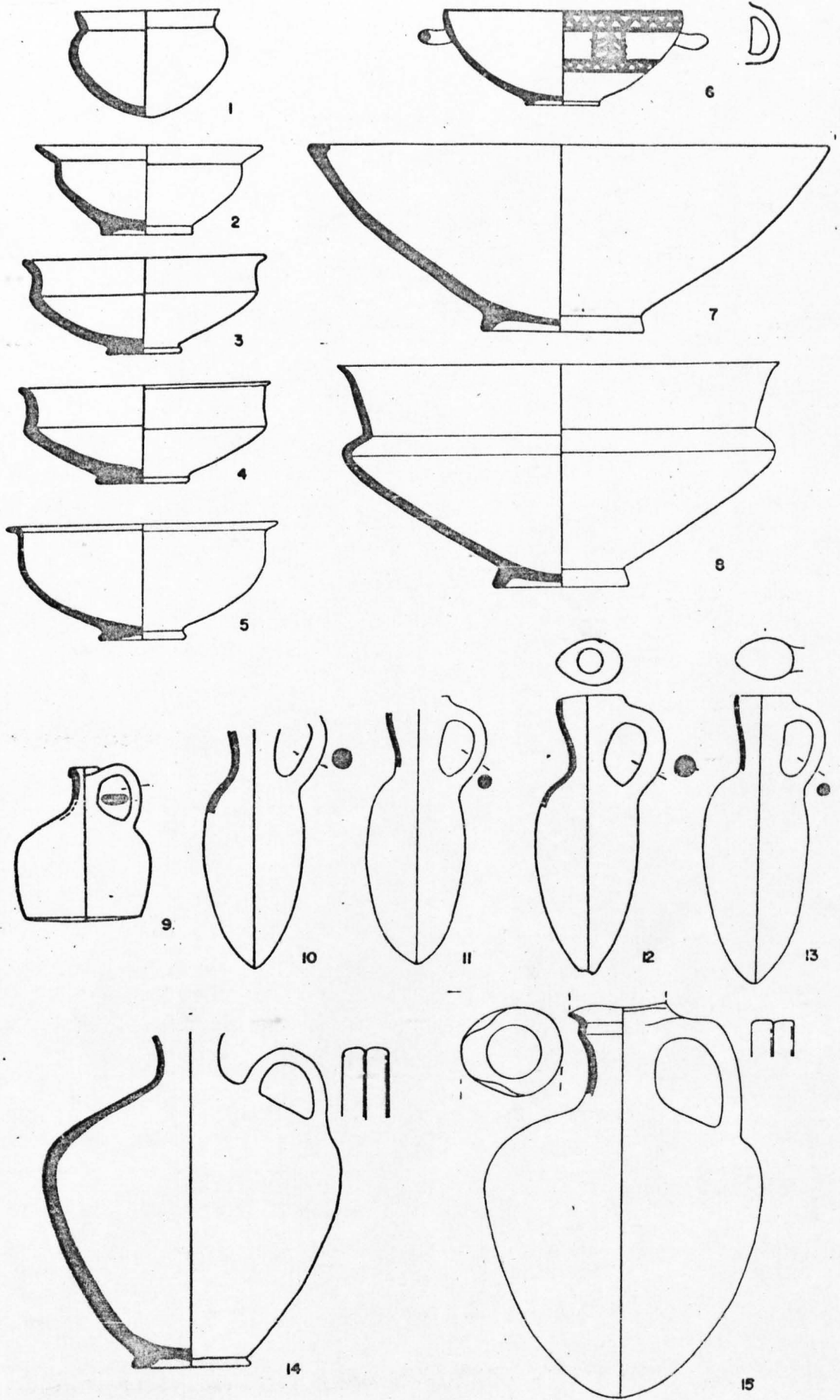

1/4

FIG. 54

F570

Plan

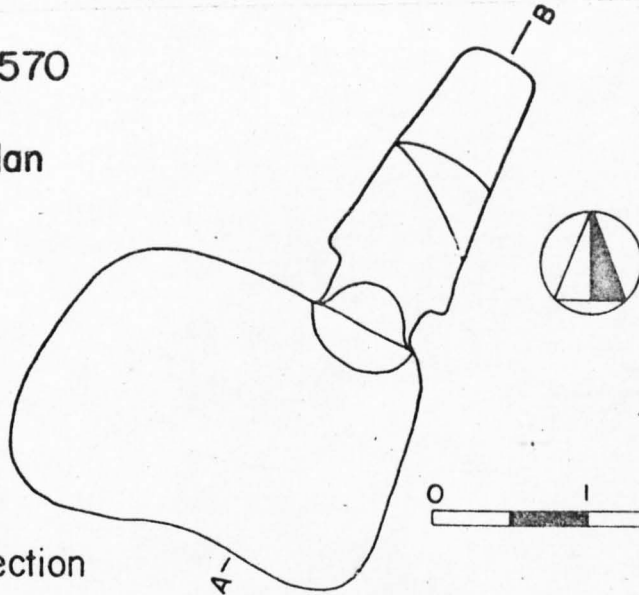

Section

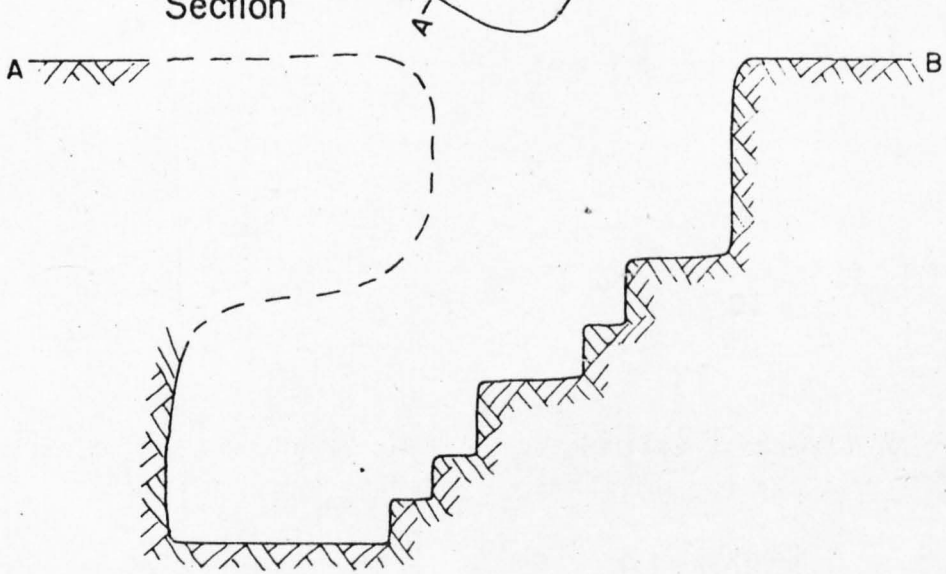

FIG. 56A

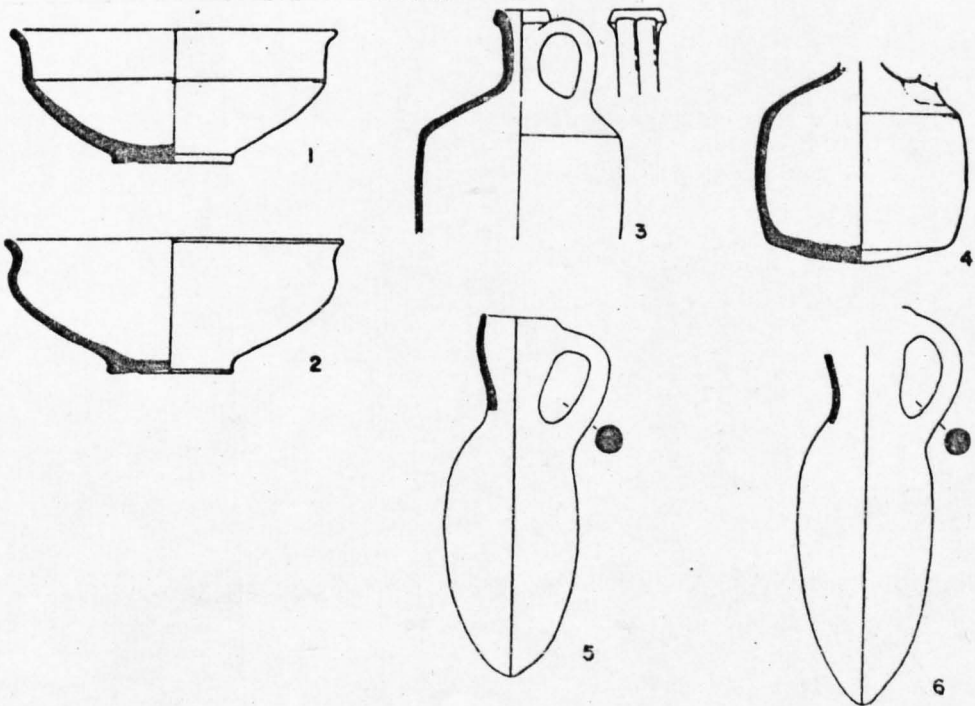
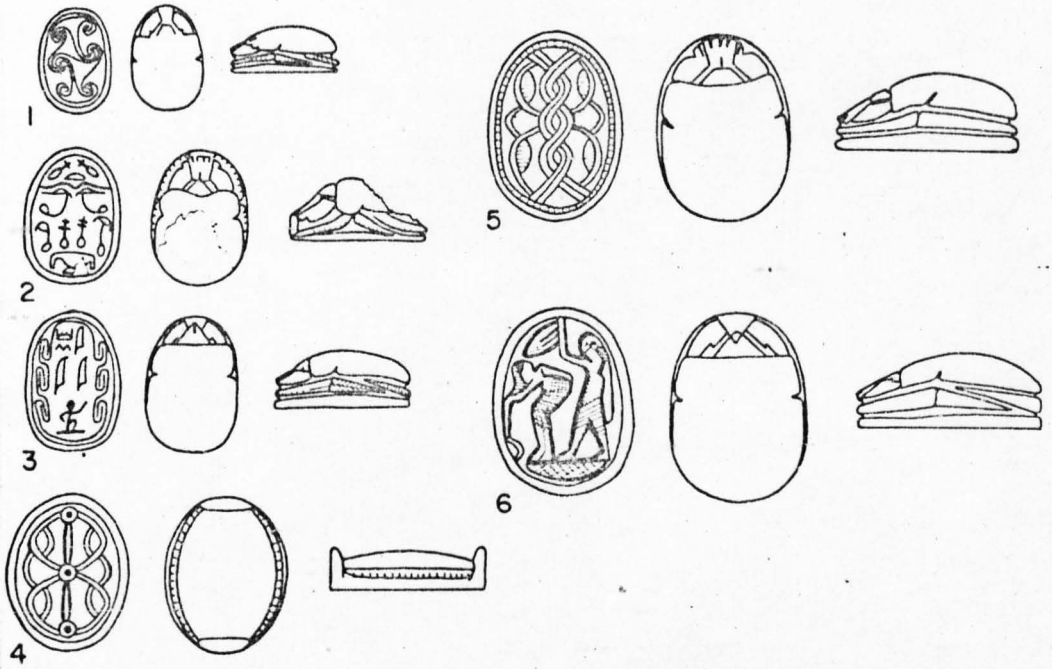
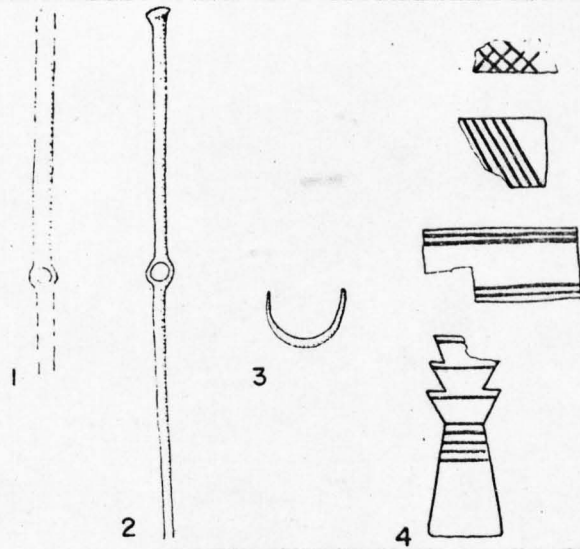

FIG. 56B



1/1

FIG. 57A



1/2

FIG. 57B



F571  
Plan

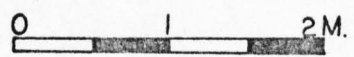
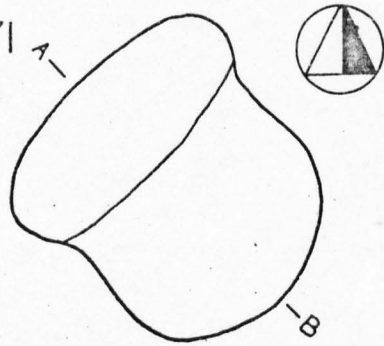

Section

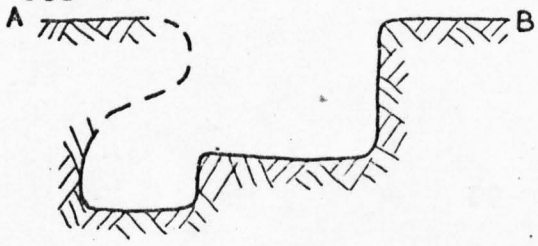
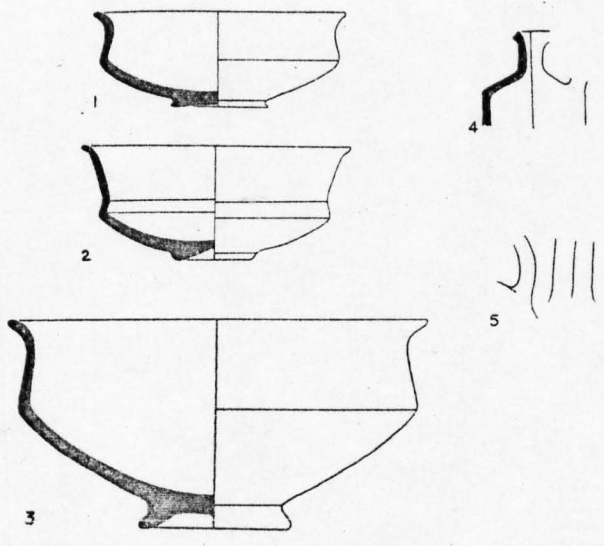

FIG. 58A



1/4

FIG. 58B

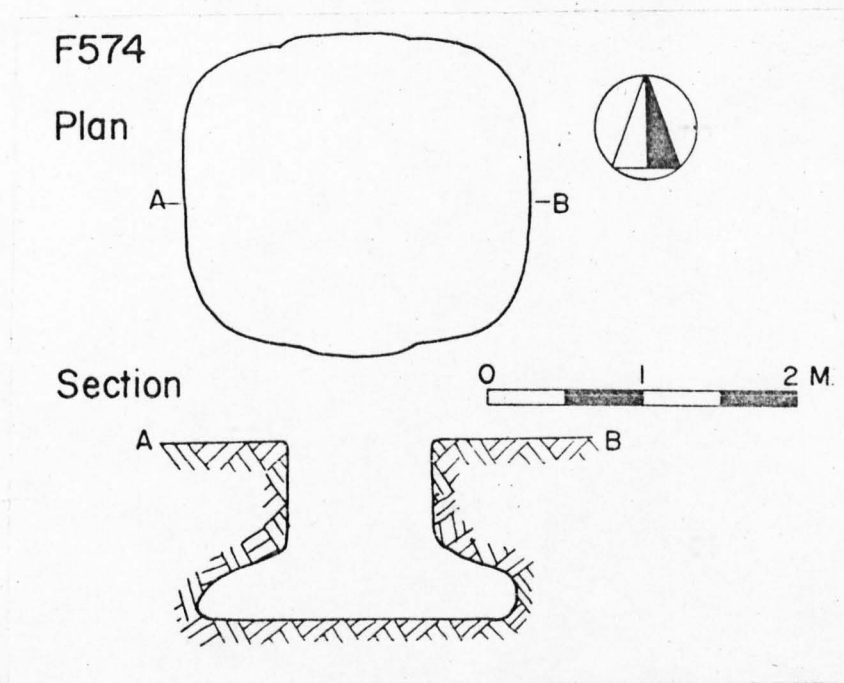
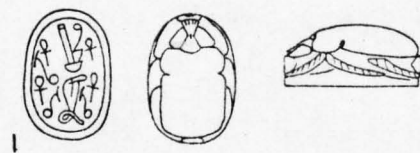

FIG. 59A



1/1

FIG. 59B

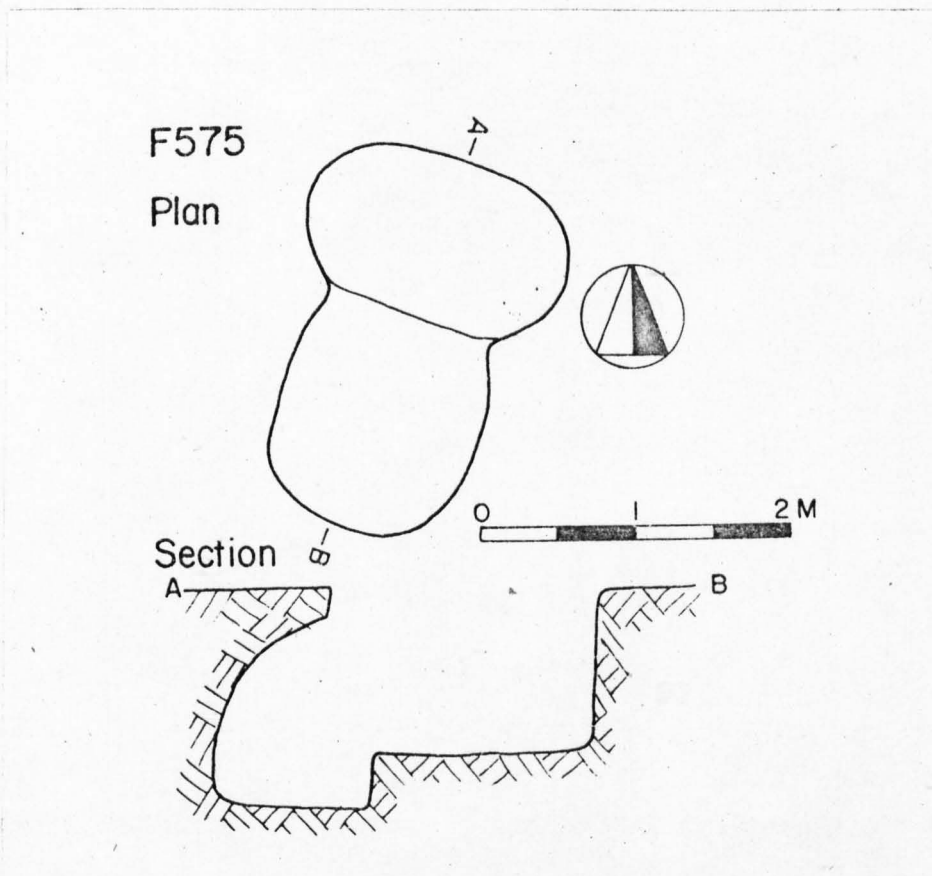

FIG. 60A

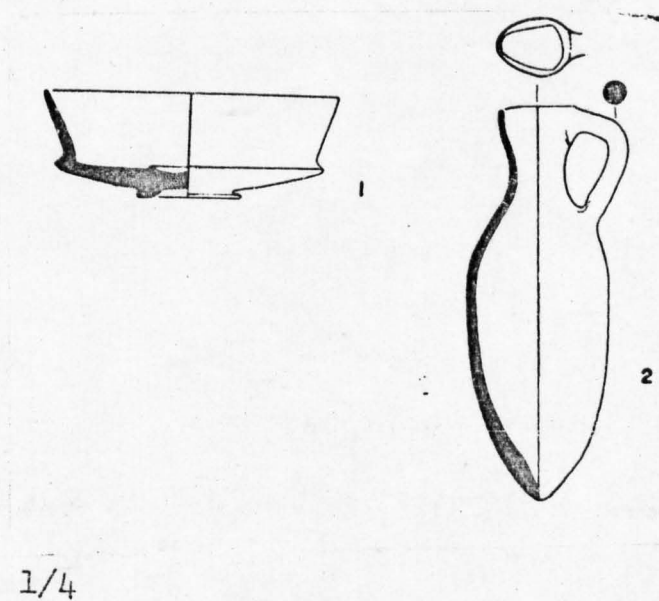

FIG. 60B

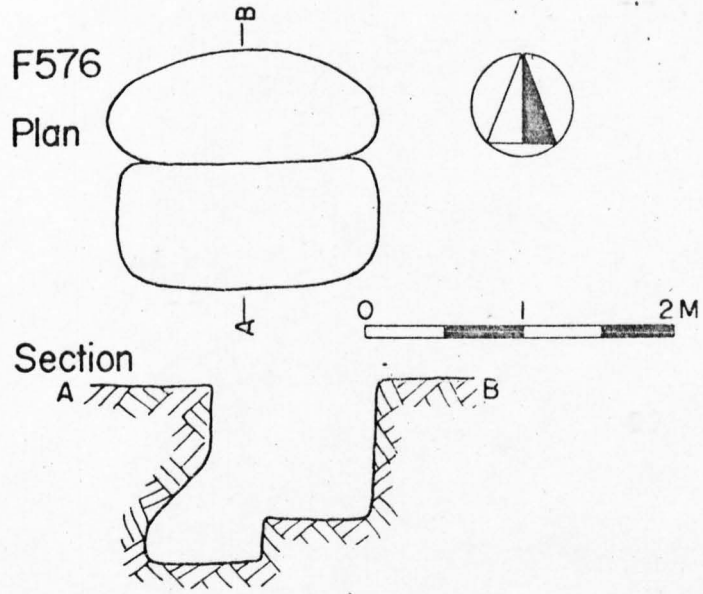

FIG. 61

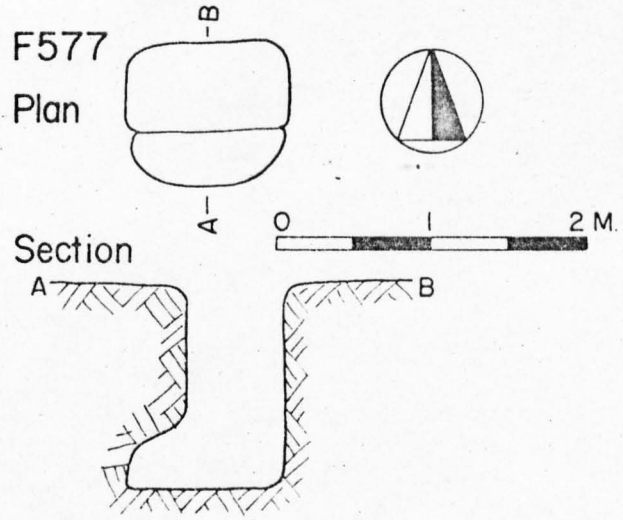
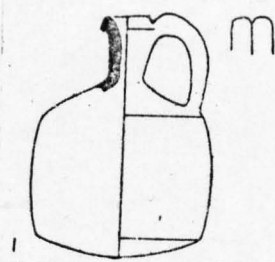

FIG. 62A



1/4

FIG. 62B

F578  
Plan

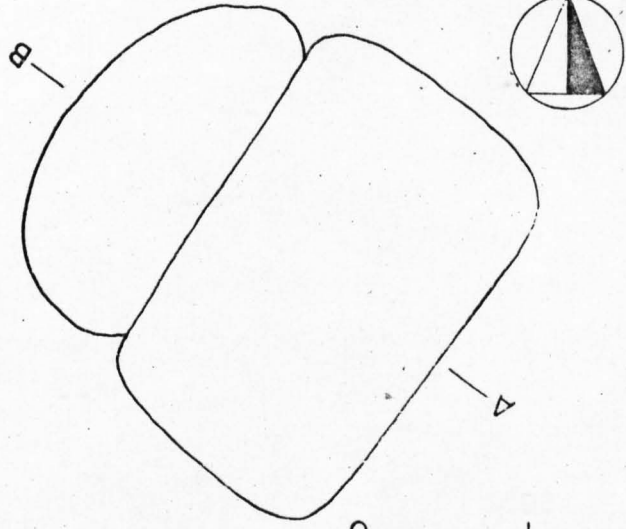

Section

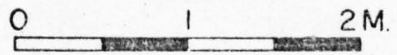
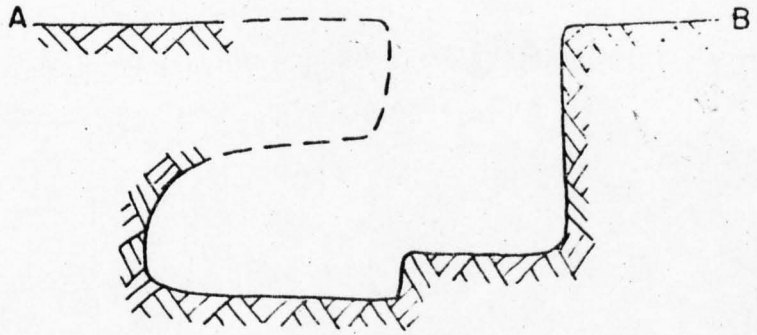

FIG. 63



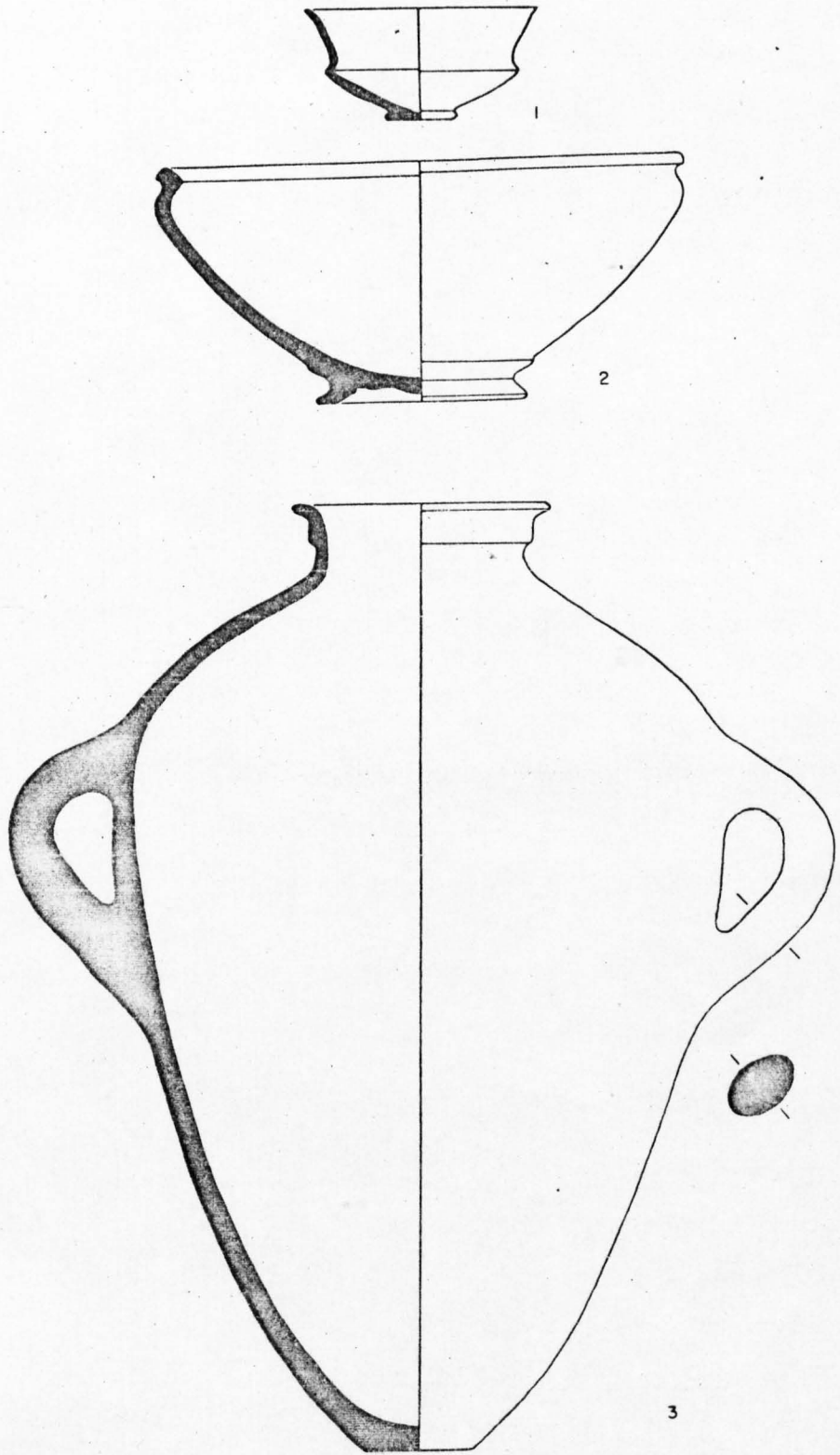
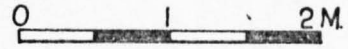
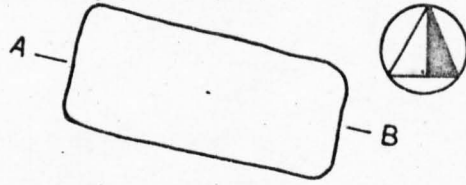

FIG. 64



F579

Plan



Section

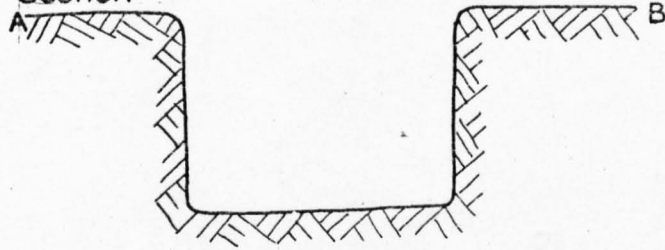
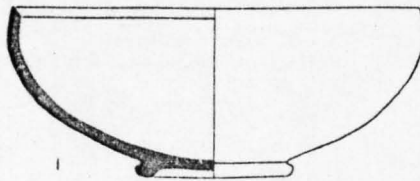

FIG. 65A



1/4

FIG. 65B

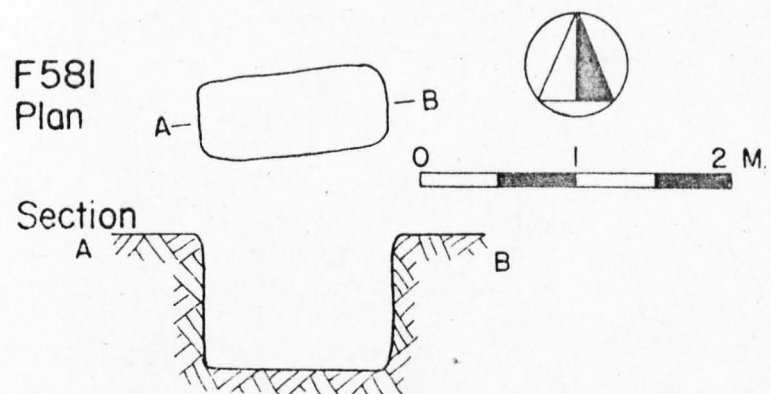
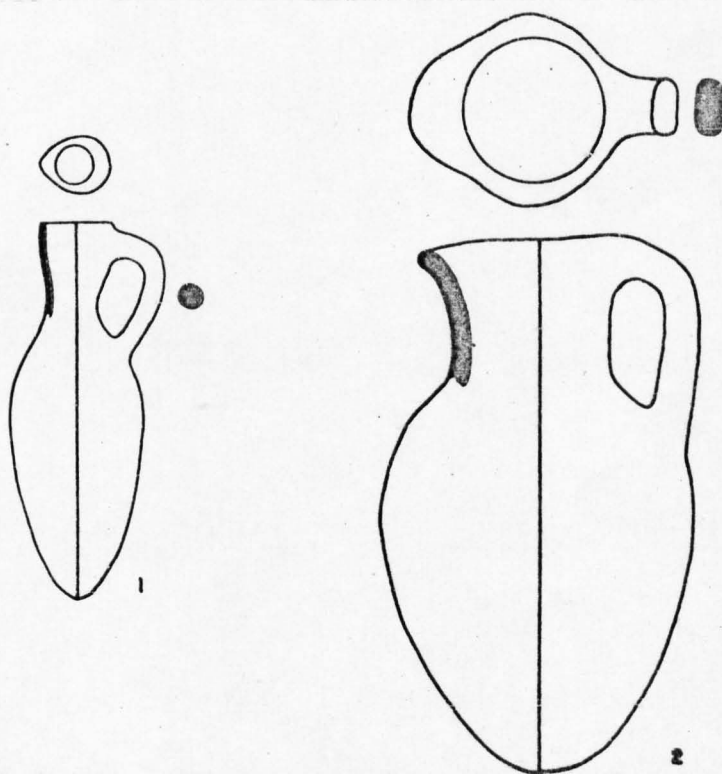

FIG.66A



1/4

FIG.66B

F582

Plan

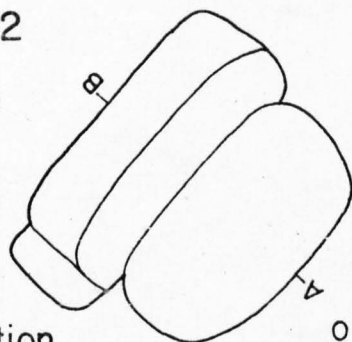

Section

0 1 2 M.

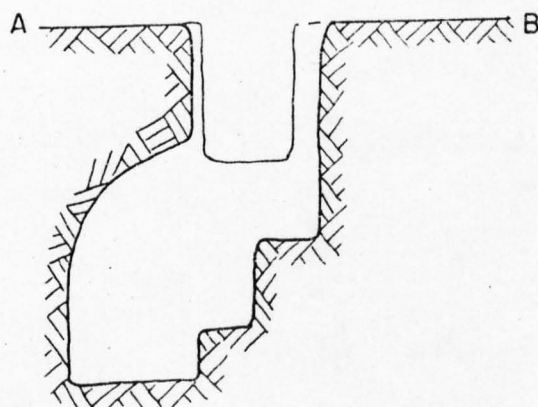
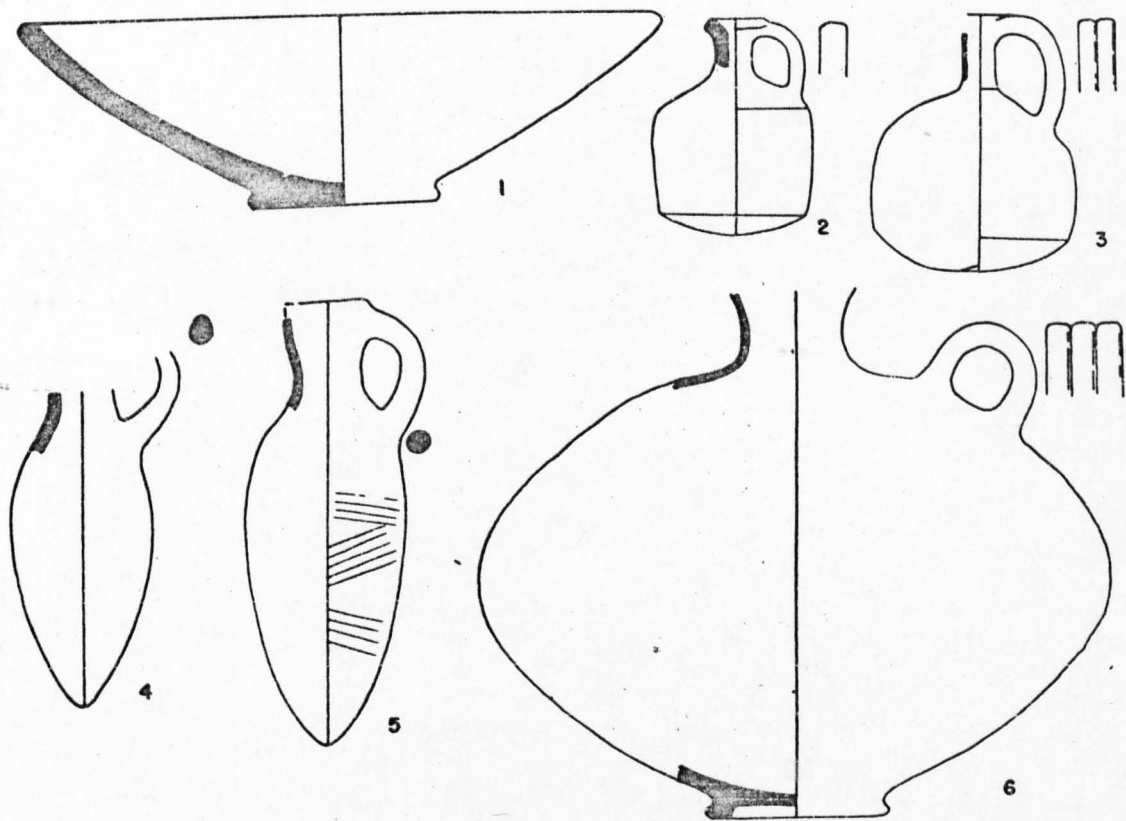
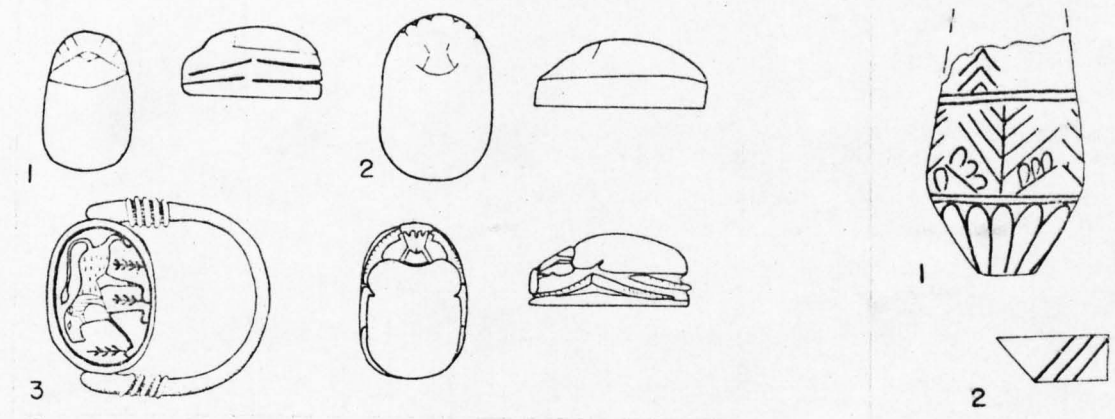

FIG. 67



1/4

FIG.68A



1/1

1/2

FIG.68B & C

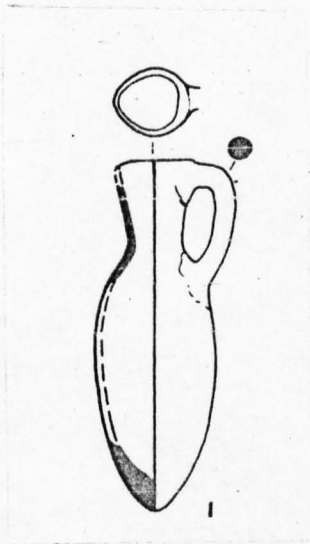

FIG. 69



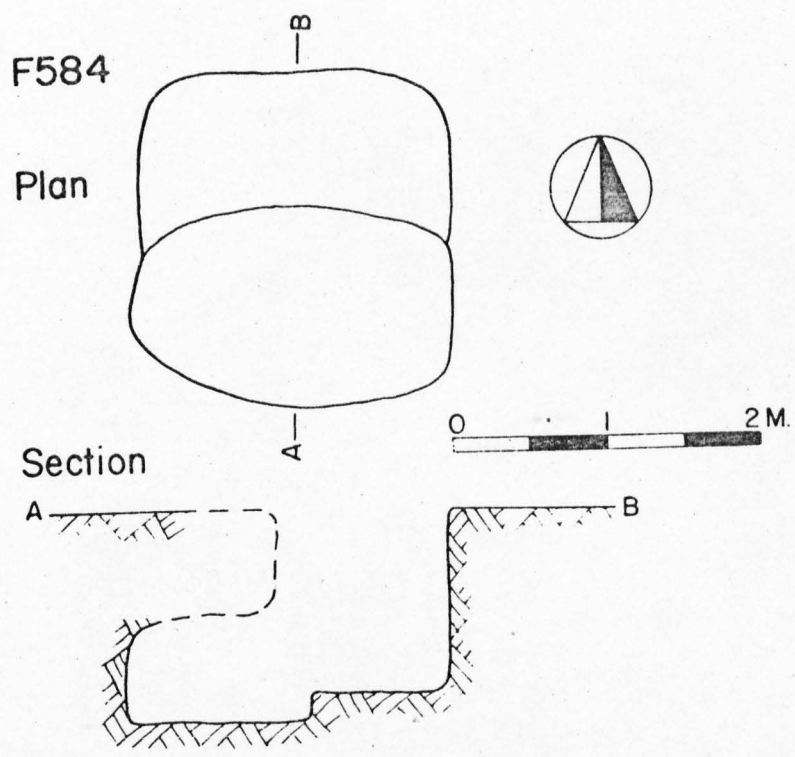
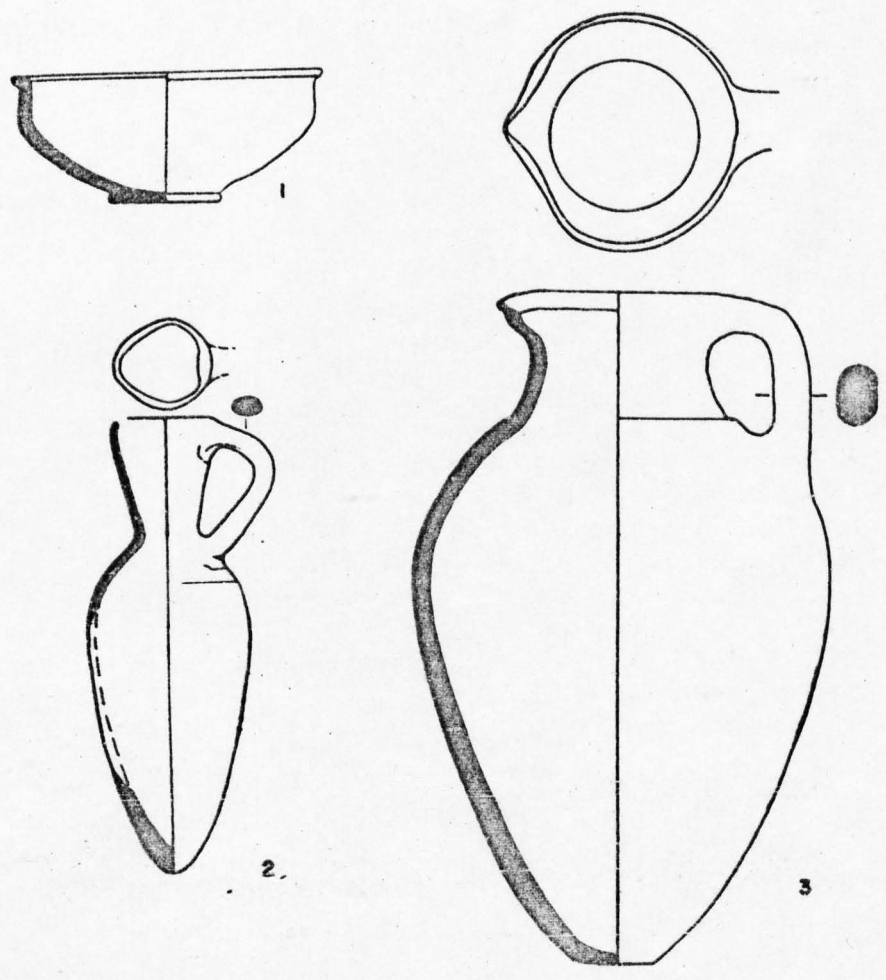
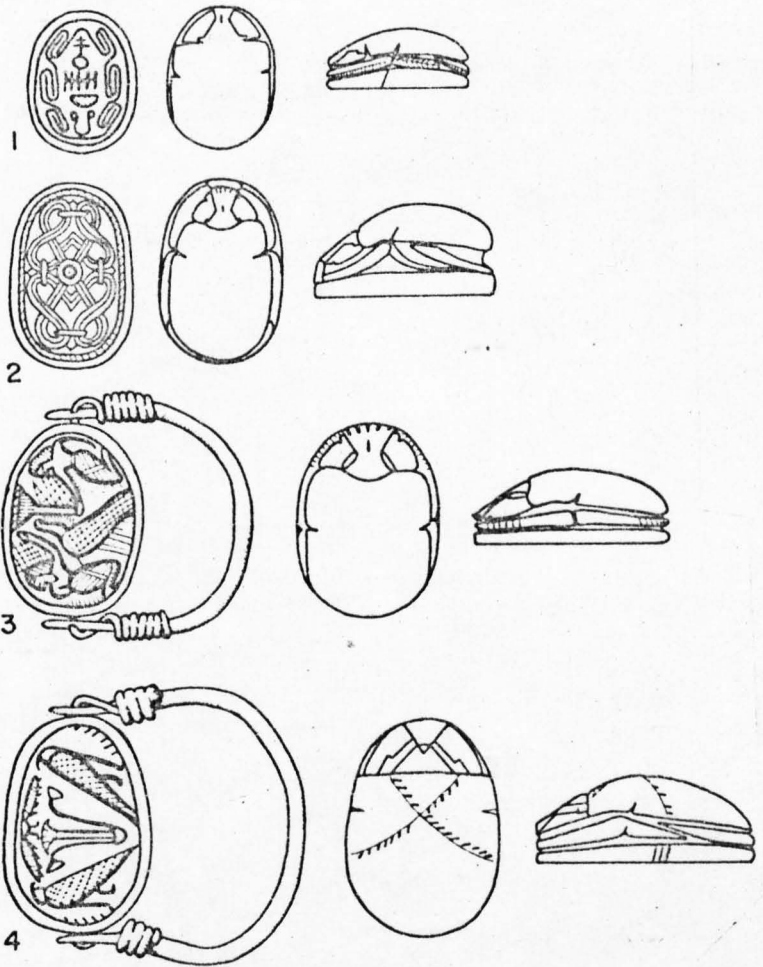

FIG. 70A



1/4

FIG. 70B



1/1

FIG. 71A

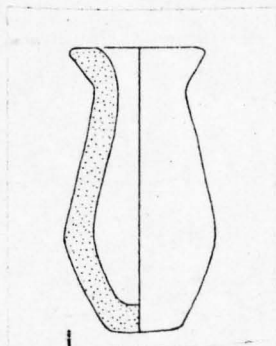

1/2

FIG. 71B



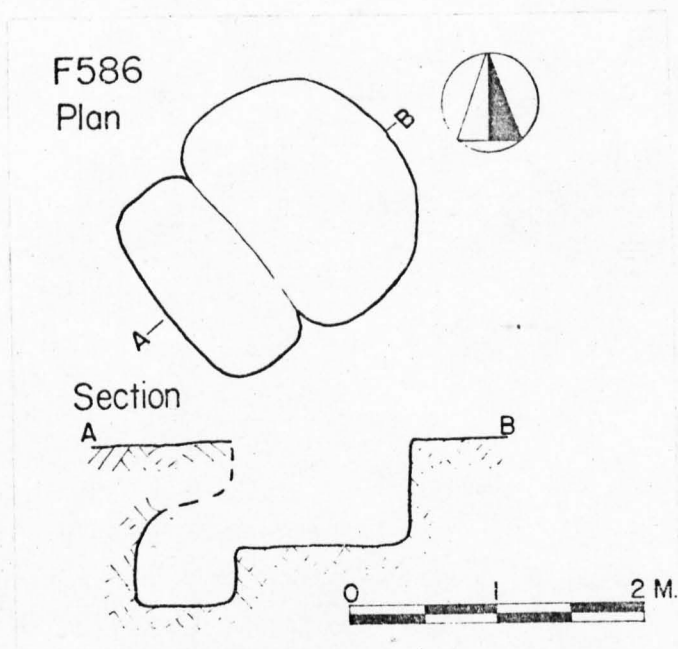
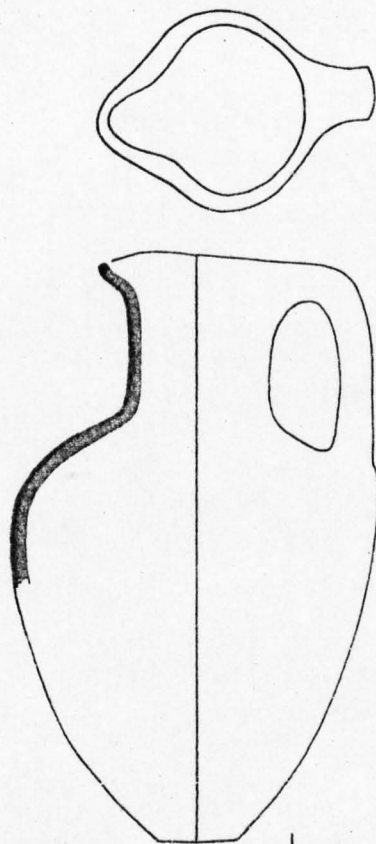

FIG. 72A



1/4

FIG. 72B

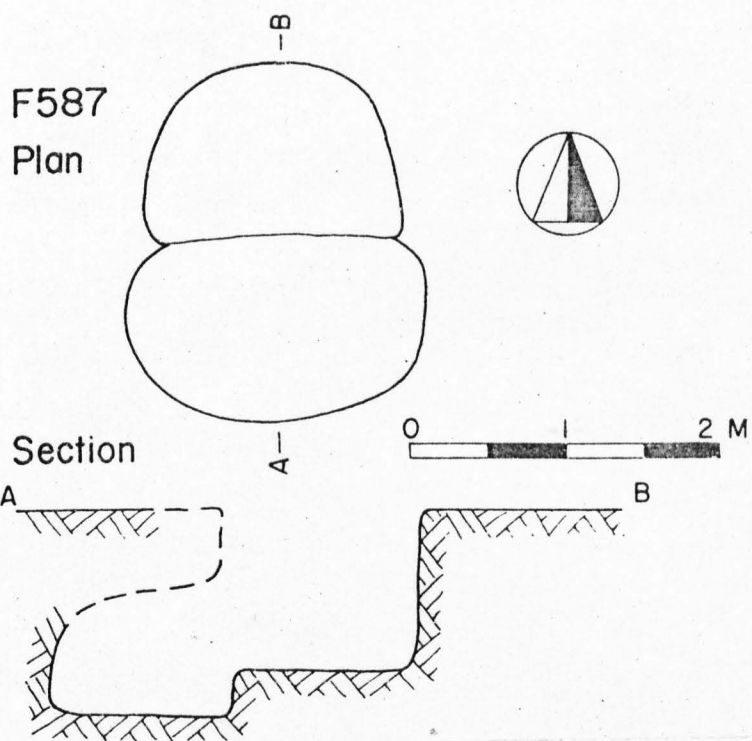
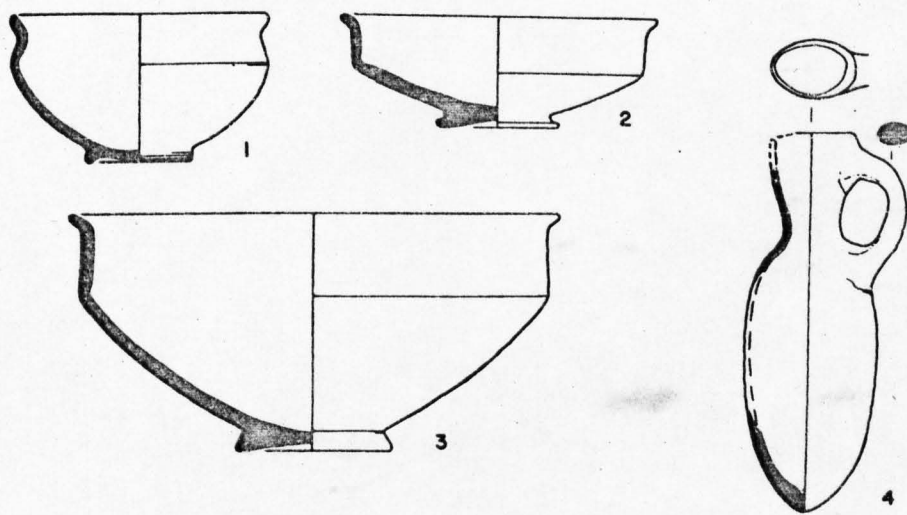
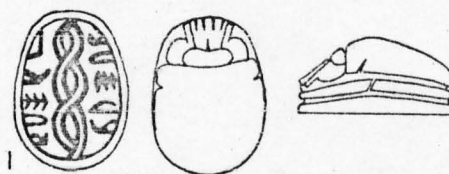

FIG. 73A



1/4

FIG. 73B



1/1

FIG. 73C

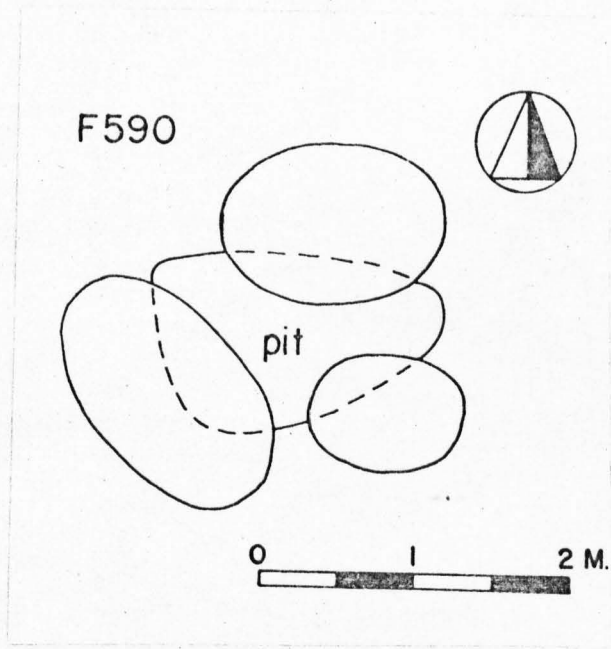
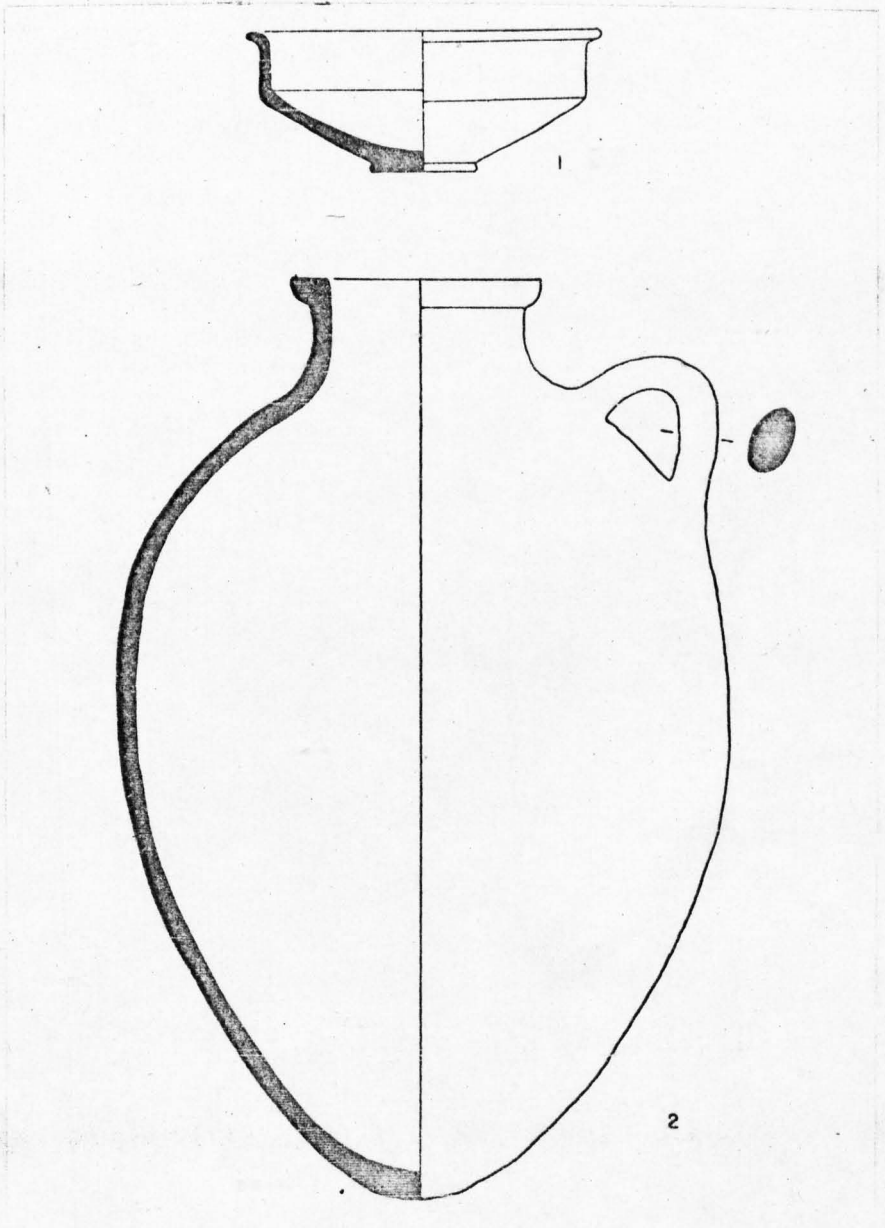
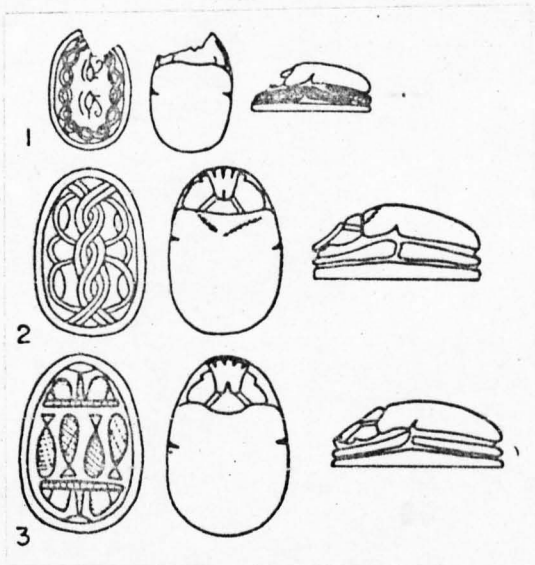

FIG. 74A



1/4

FIG. 74B



1/1

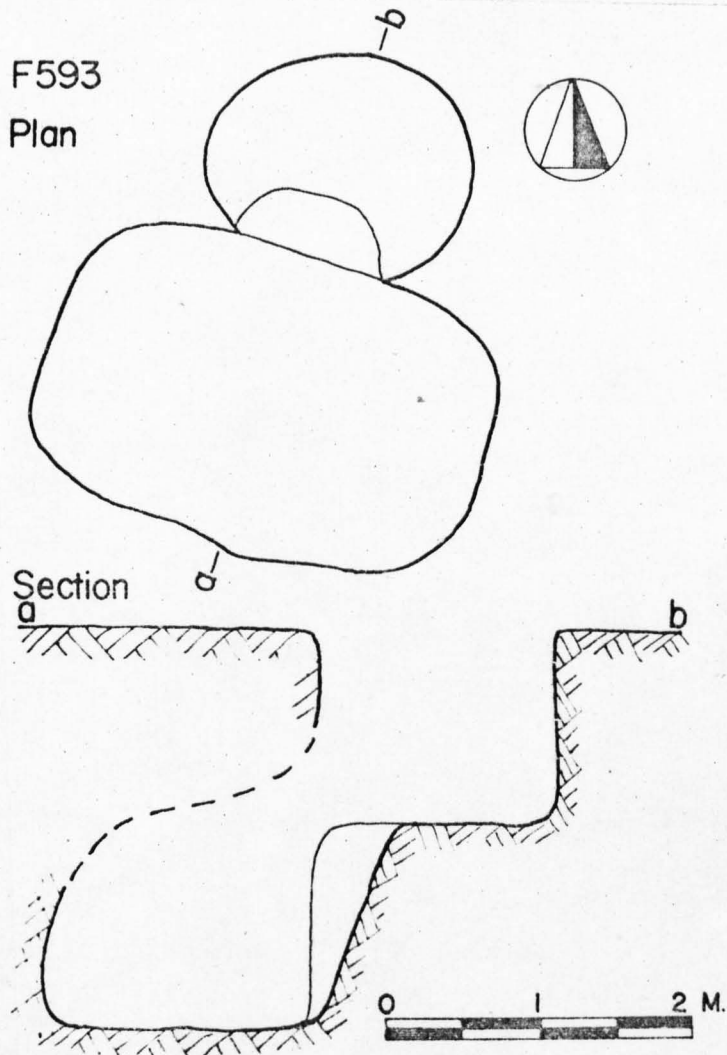
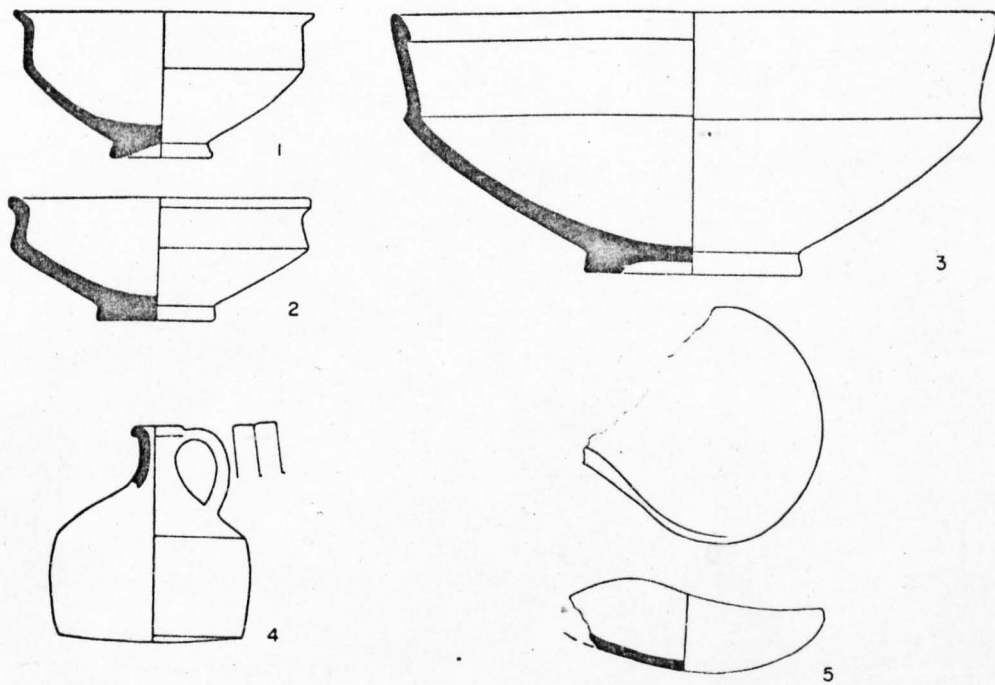

FIG.76





1/4

FIG. 77A

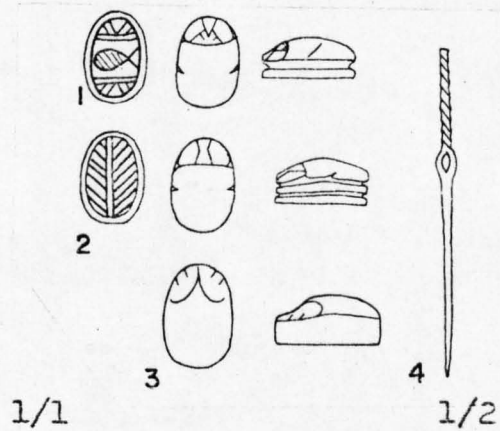

1/1

1/2

FIG. 77B

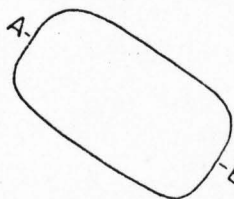

F594  
Plan

0 1 2 M.

Section

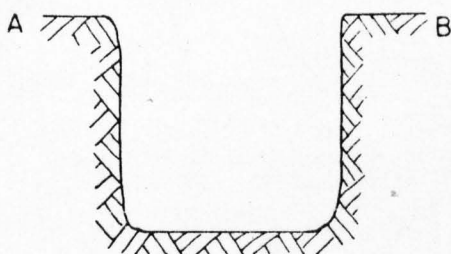
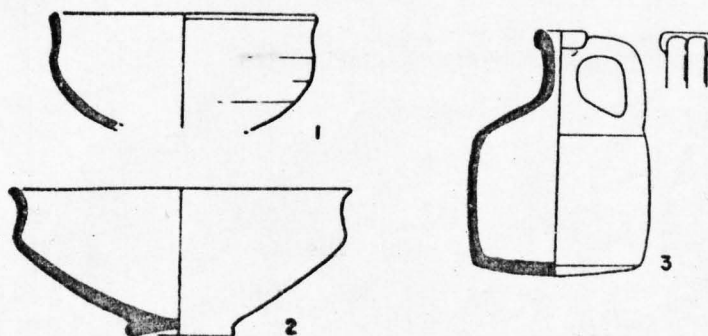

FIG. 78A



1/4

FIG. 78B

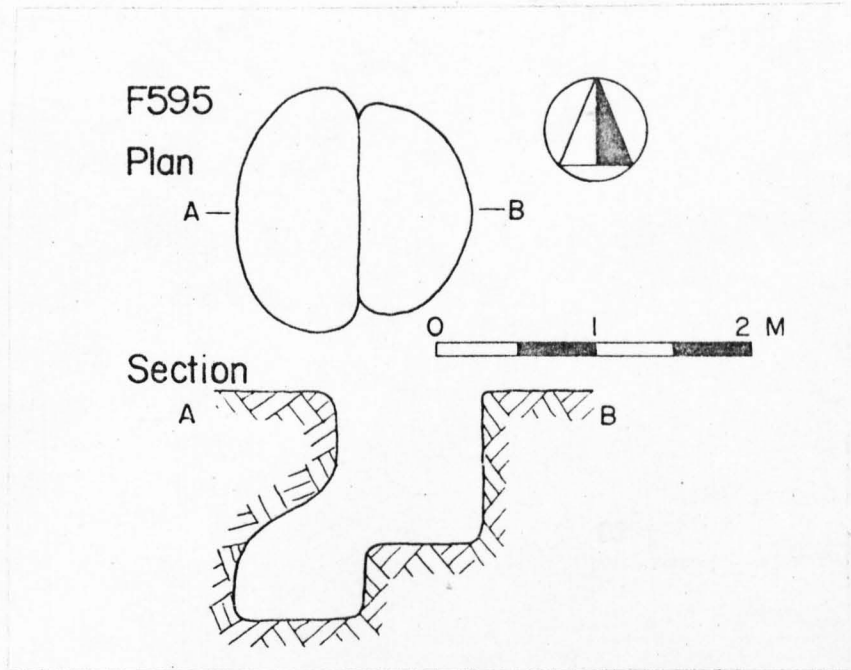
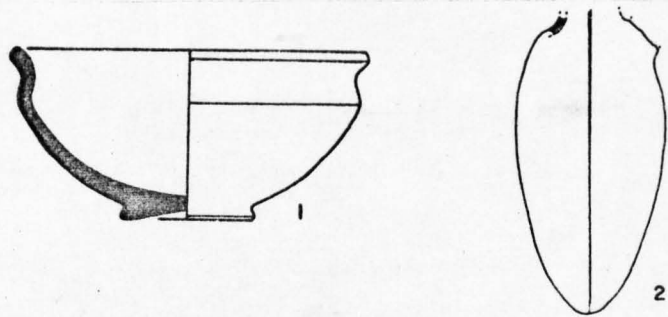

FIG.79A



1/4

FIG.79B

F596

Plan

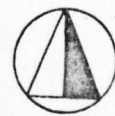
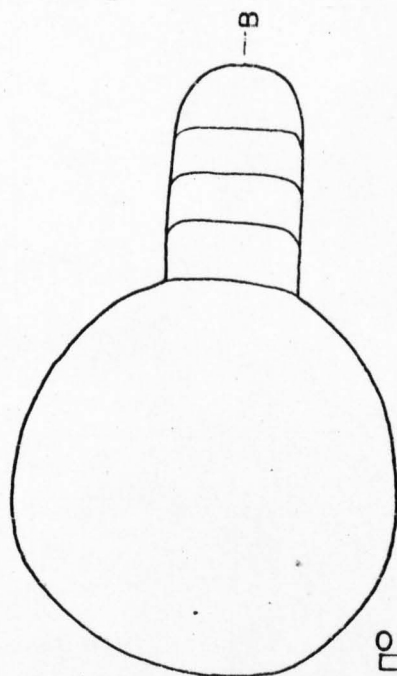

Section

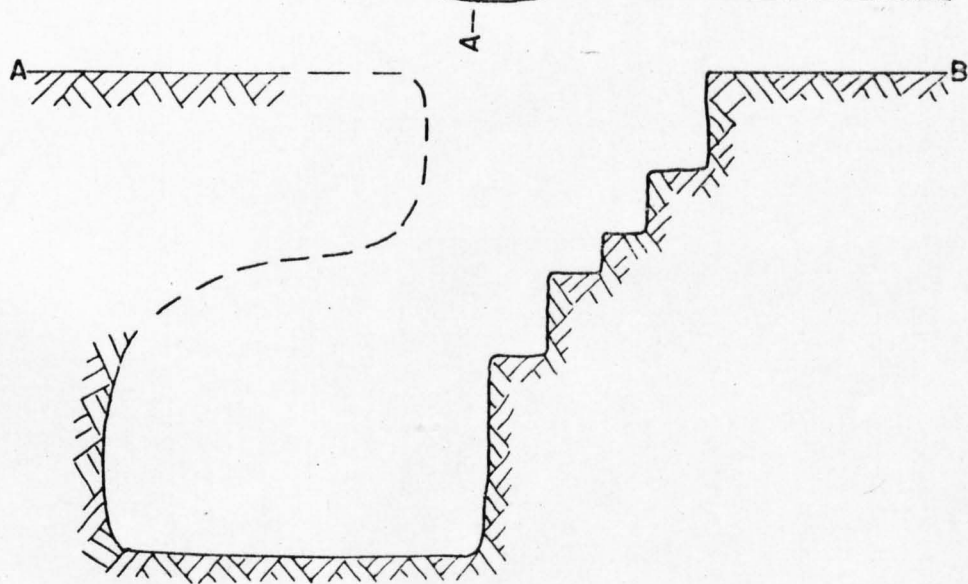
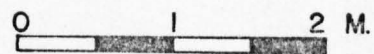
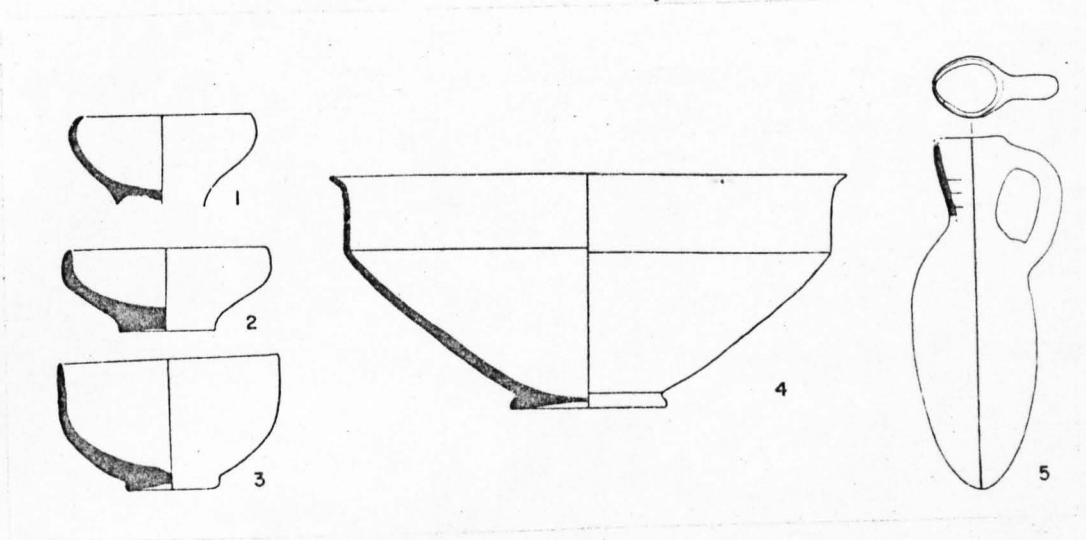
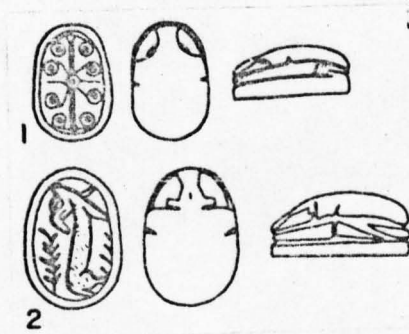

FIG. 80



1/4

FIG. 81A



1/1

FIG. 81B

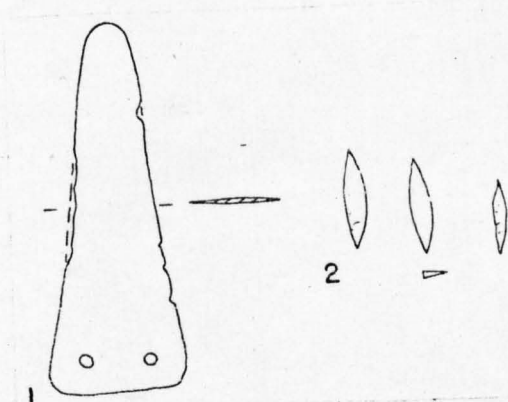

1/2

FIG. 81C

F 558  
Plan

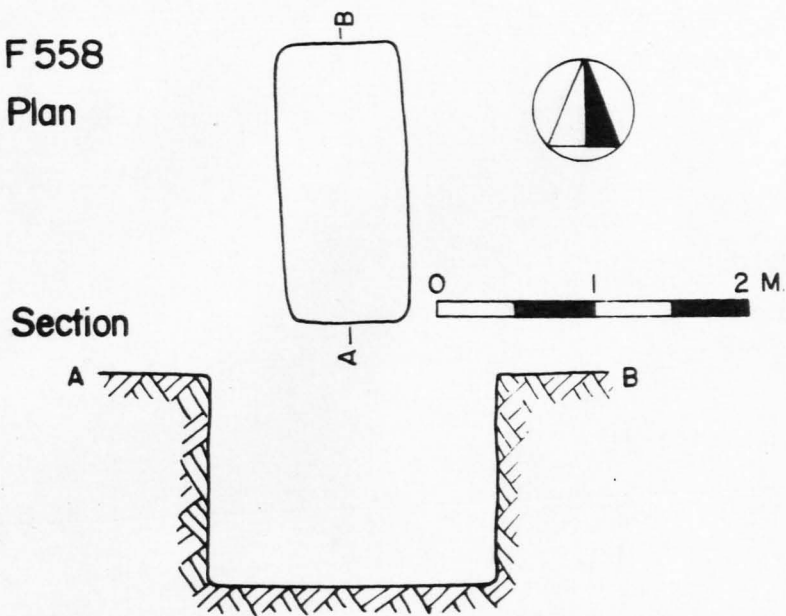

F579  
Plan

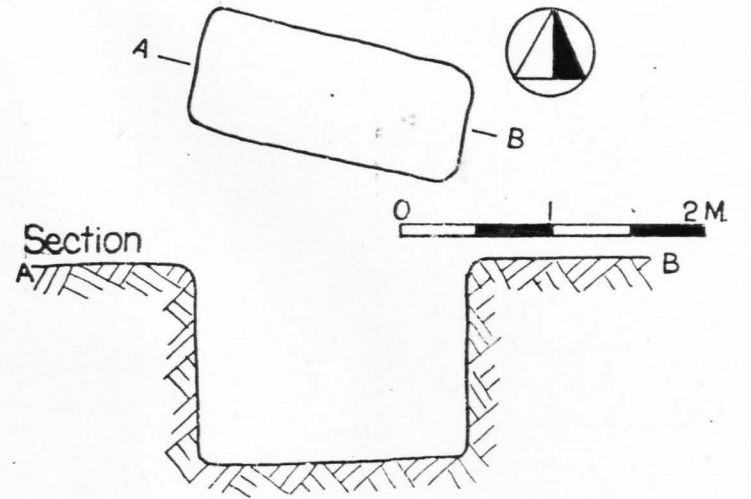

F581  
Plan

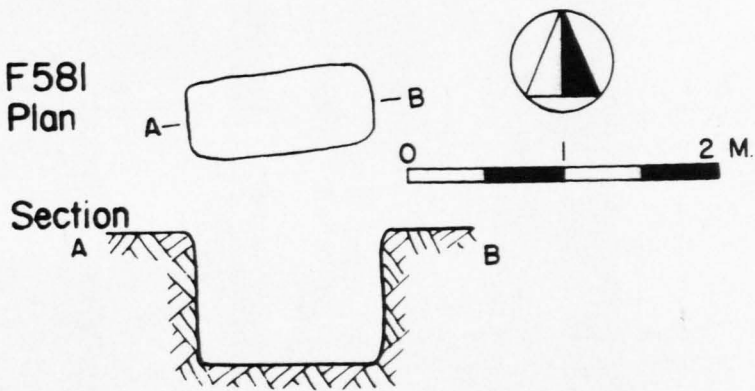

F594  
Plan

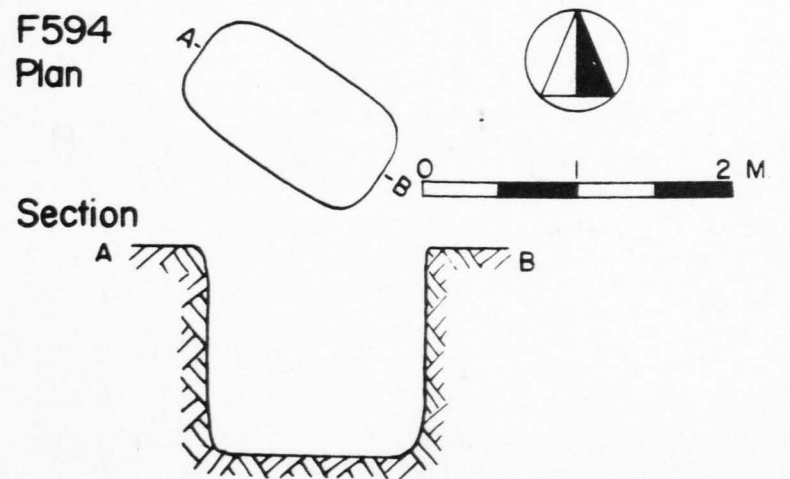



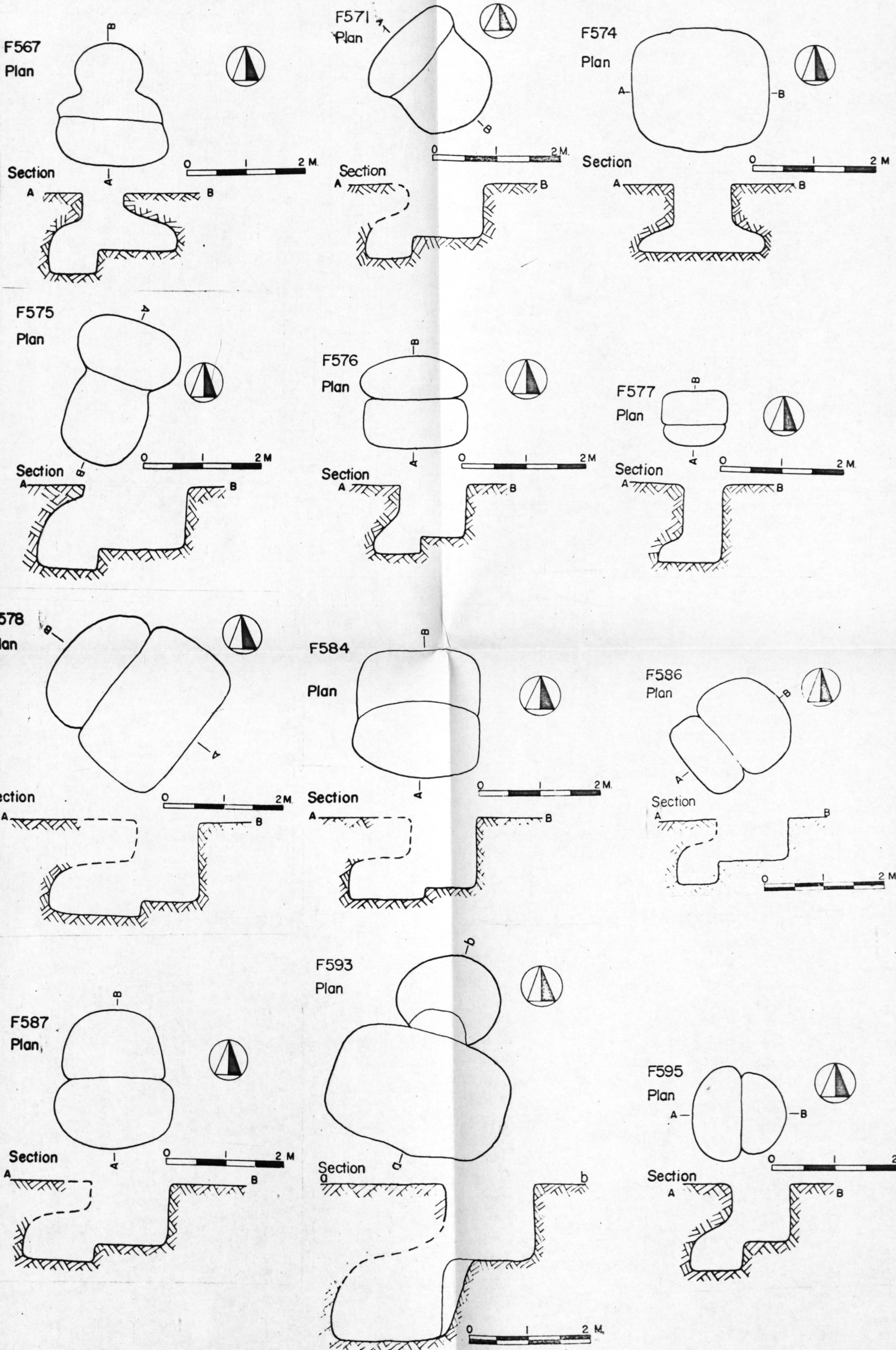
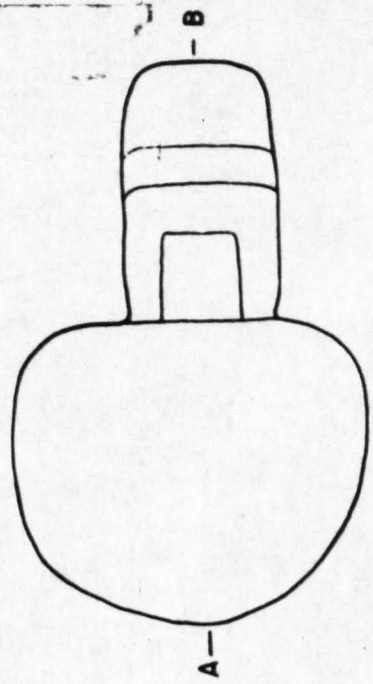

FIG. 83



F545  
Plan



Section

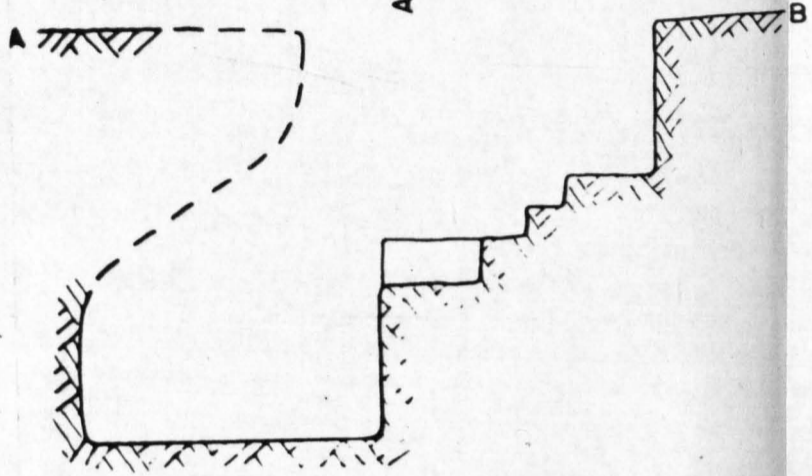

F563  
Plan



Section

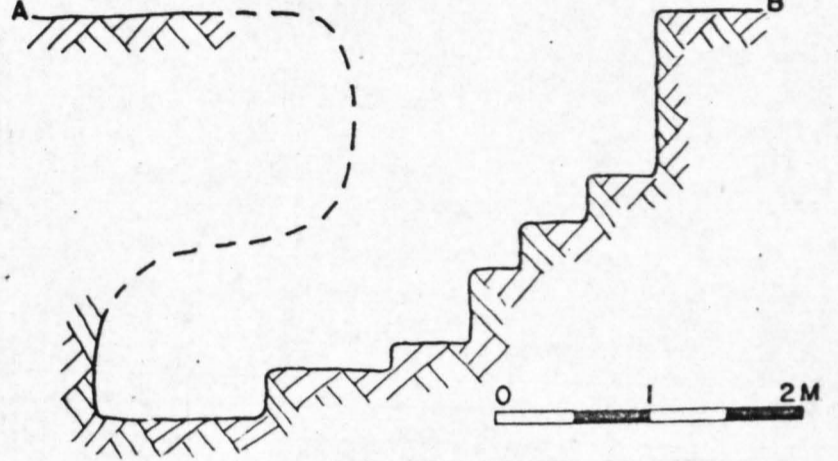

F582  
Plan

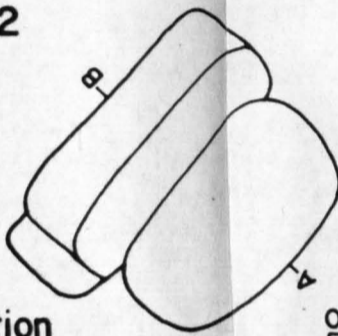

Section

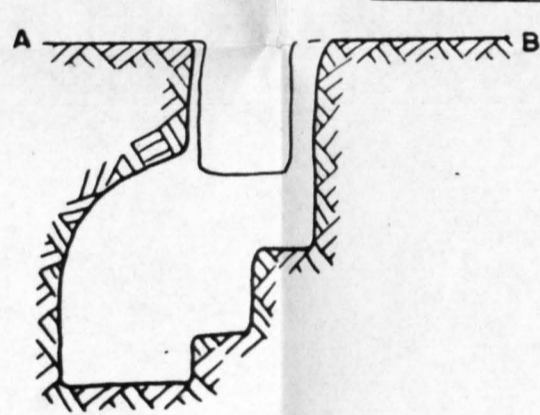

F570  
Plan

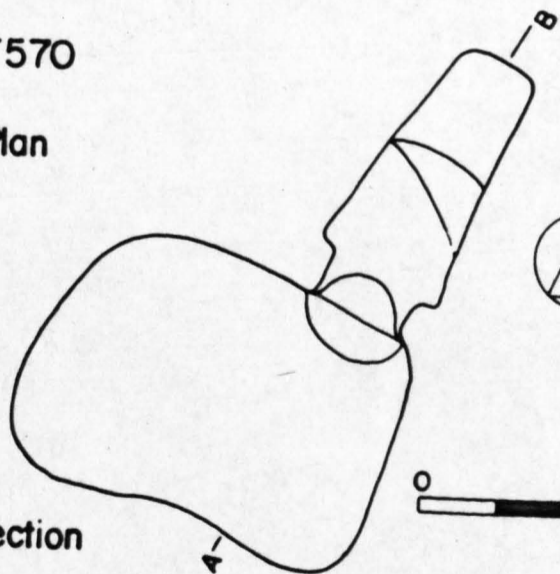

Section

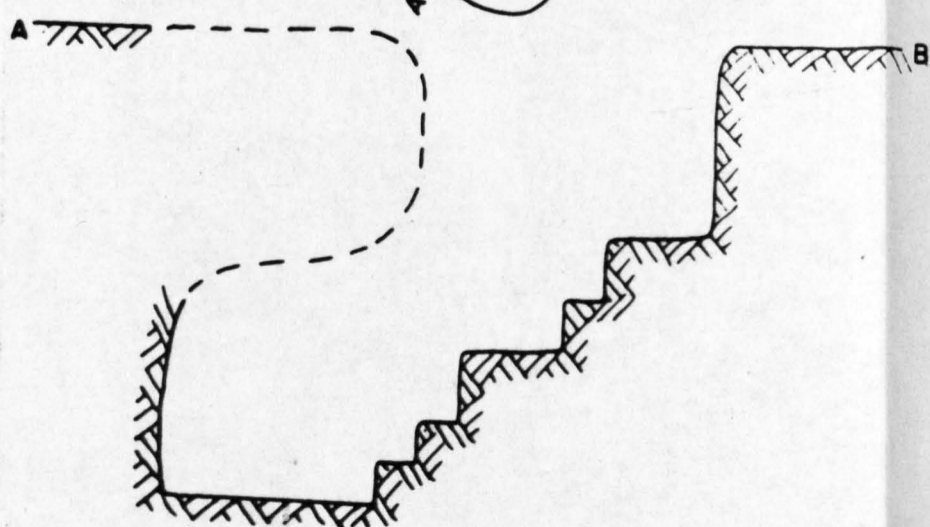

F596  
Plan

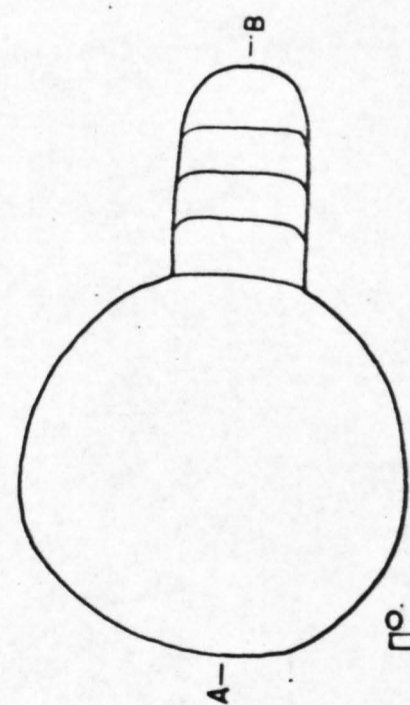

Section

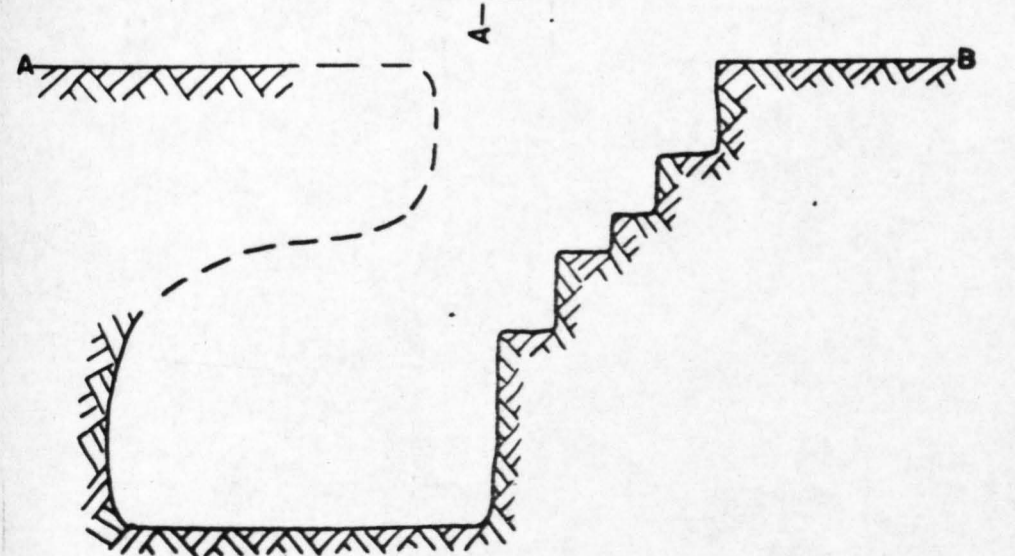



F551  
Plan

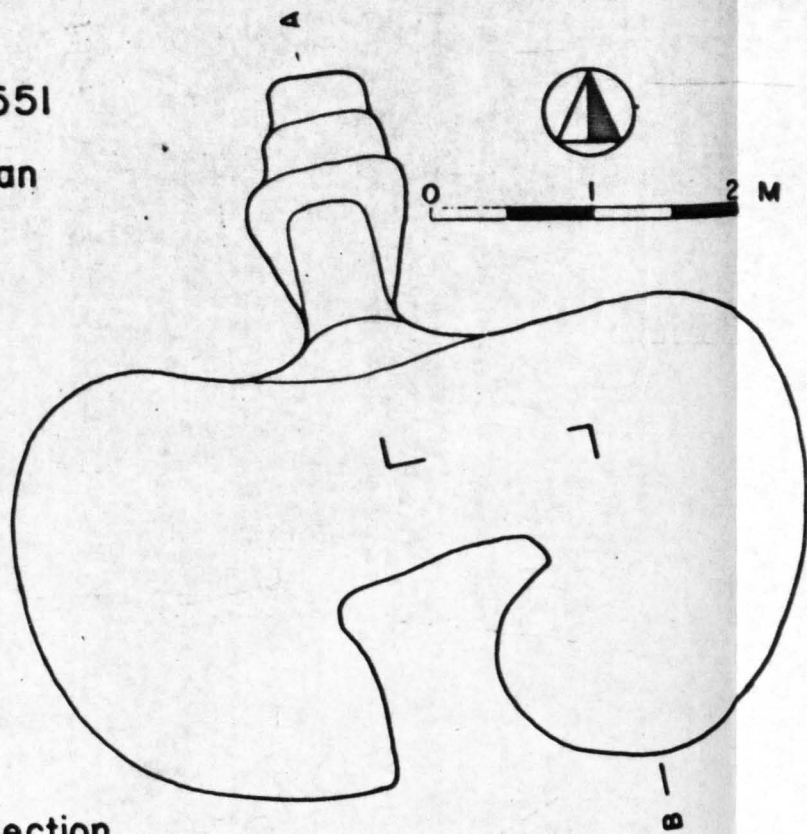

Section

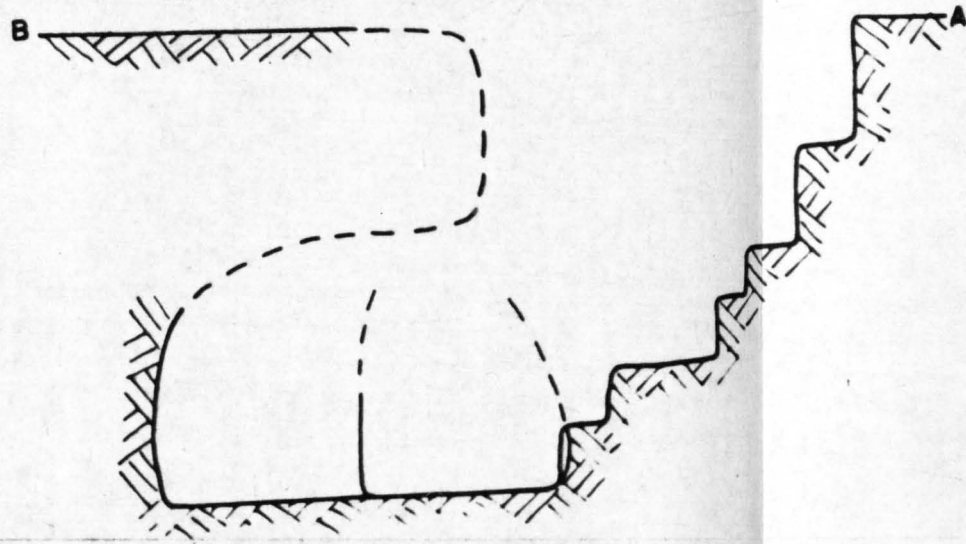

F555  
Plan

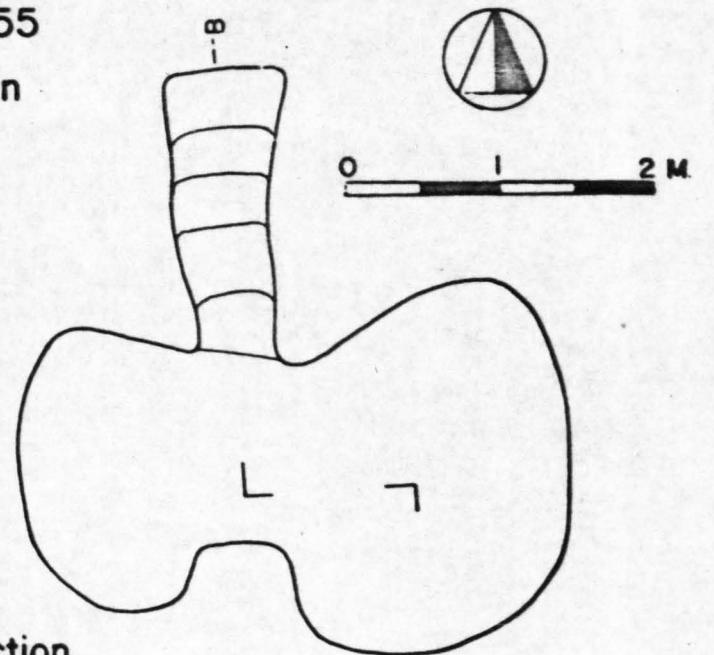

Section

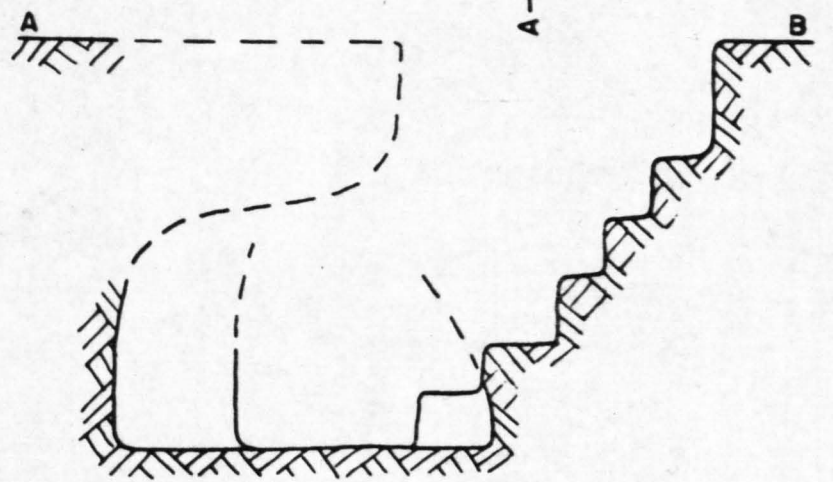

F554  
Plan

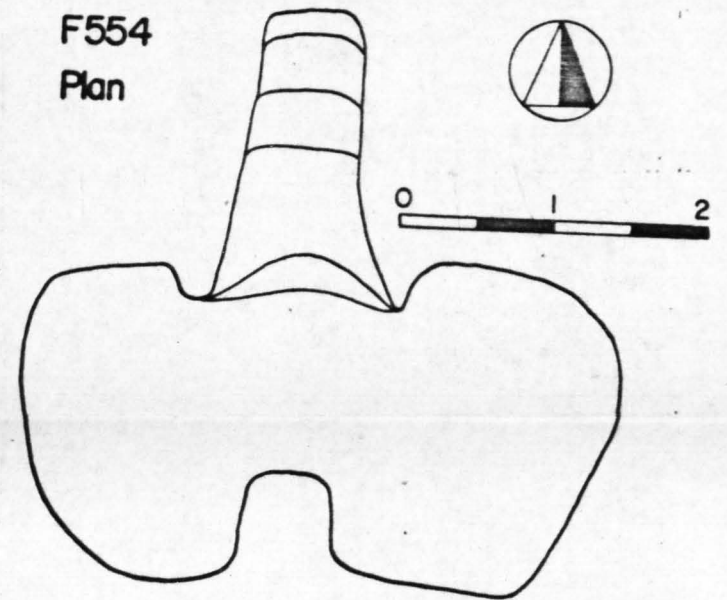

F565  
Plan

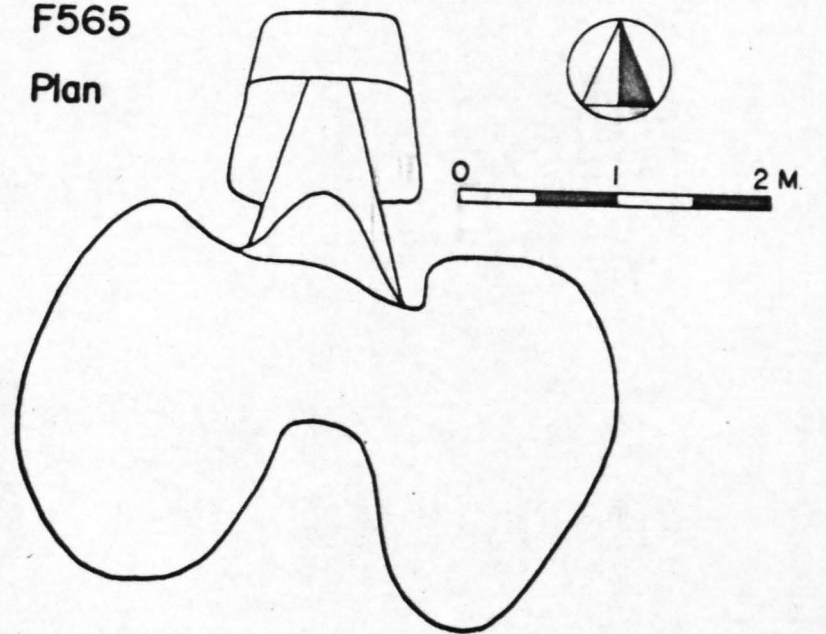

F566  
Plan

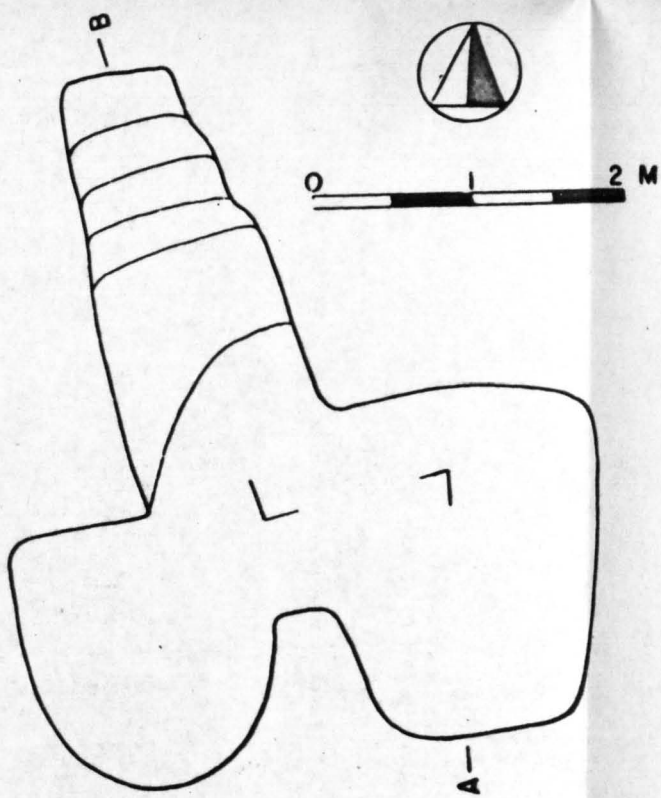

Section

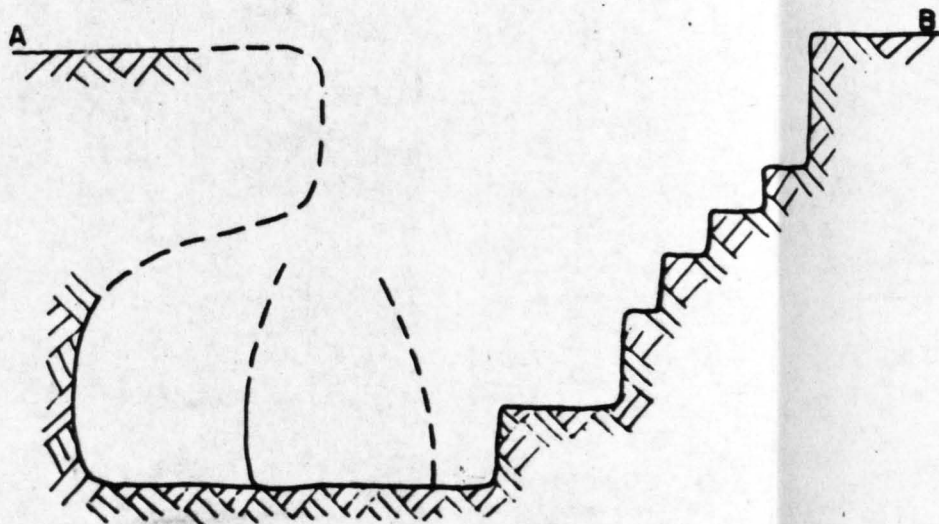

F569  
Plan

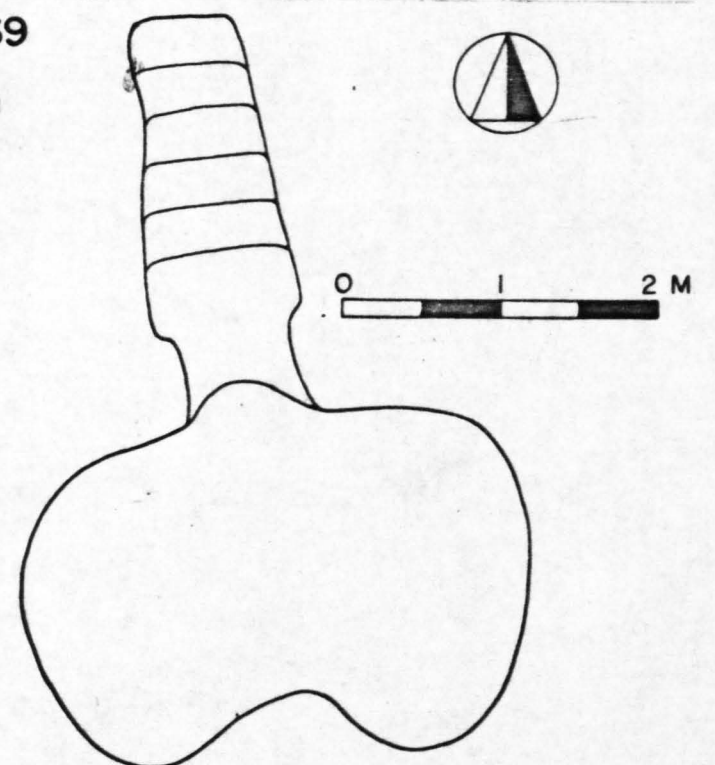



F550  
Plan

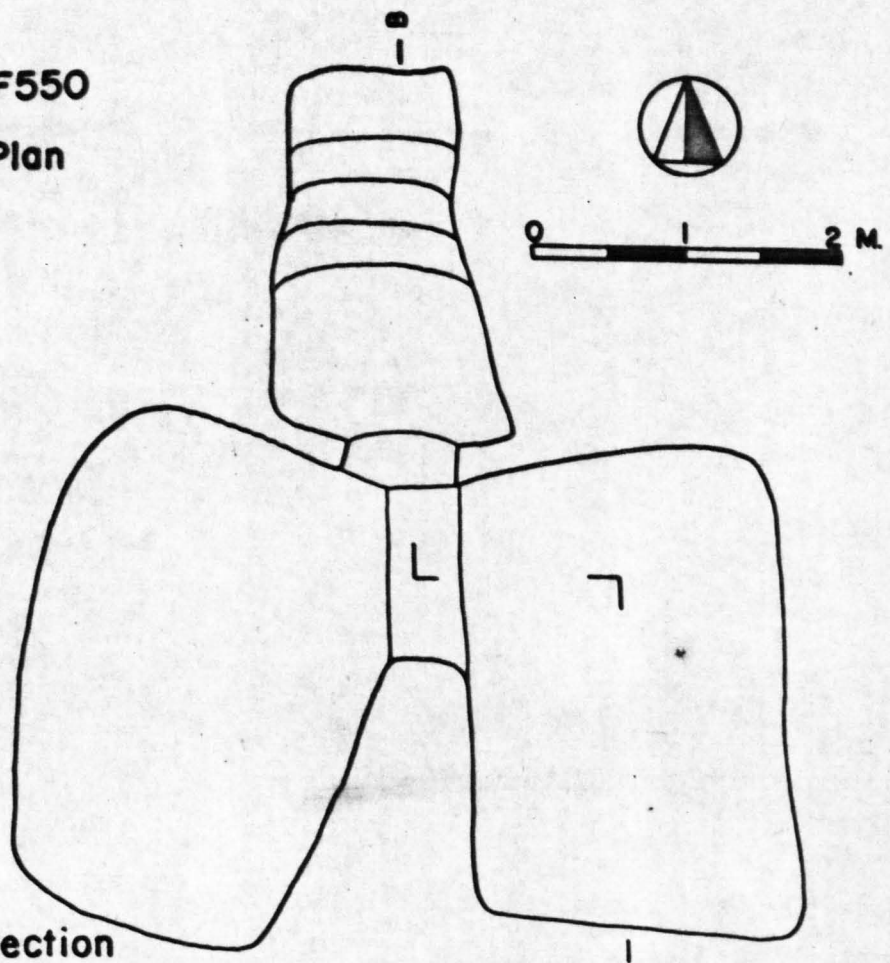

Section

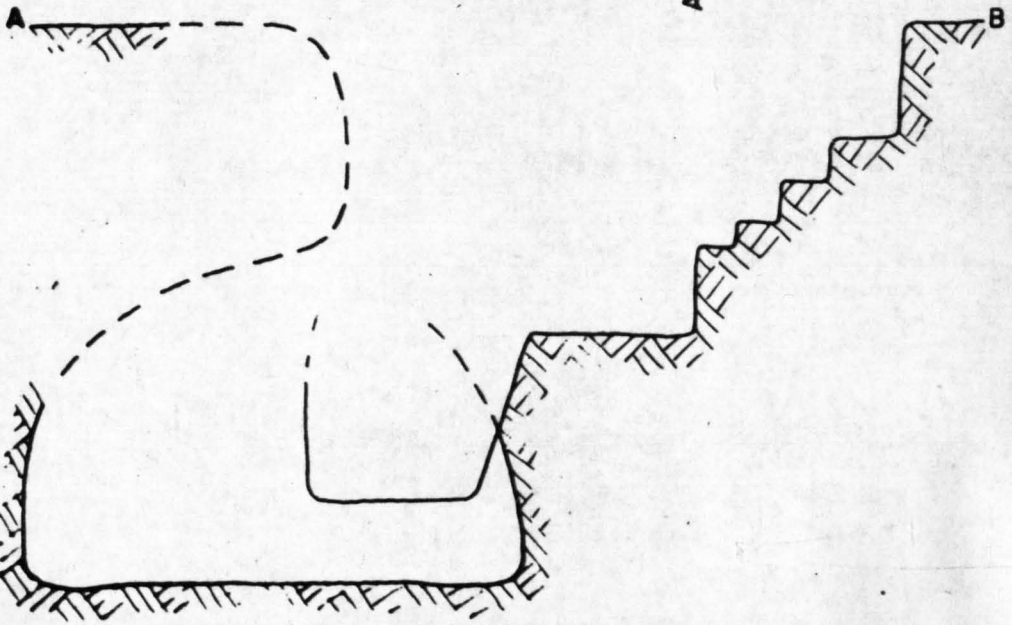

F556  
Plan

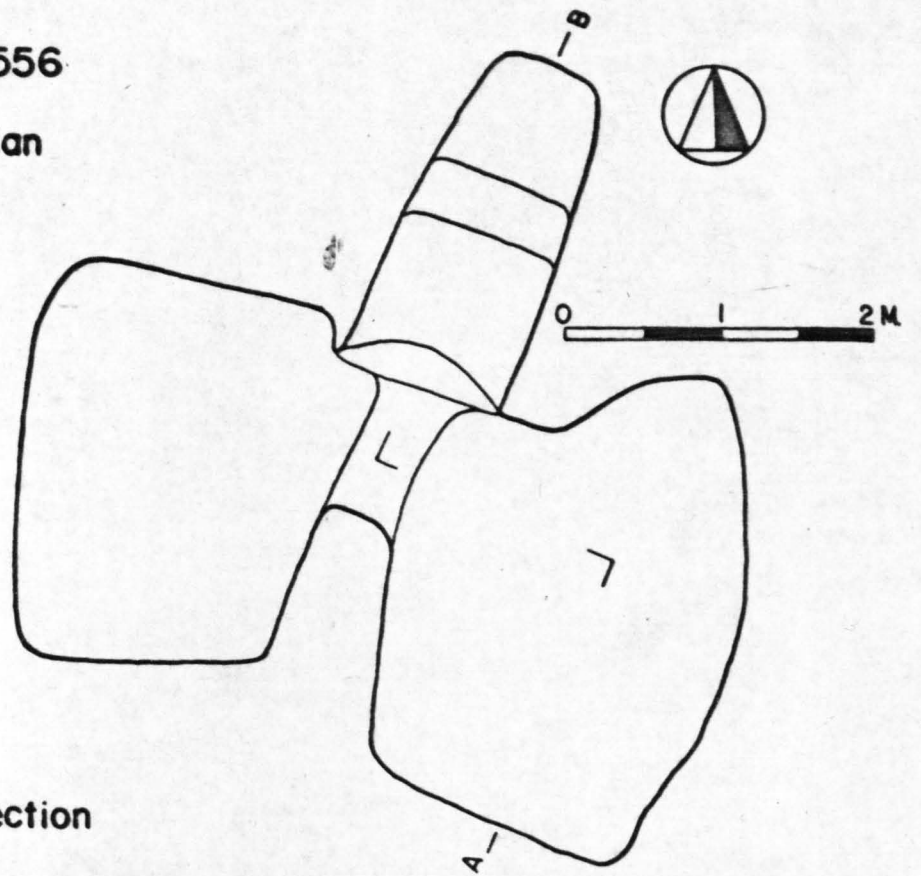

Section

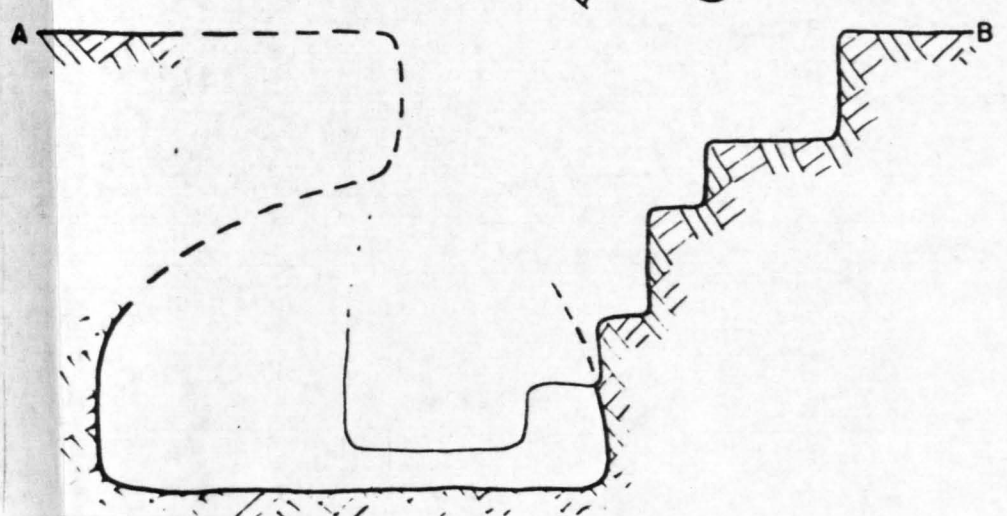

F559  
Plan

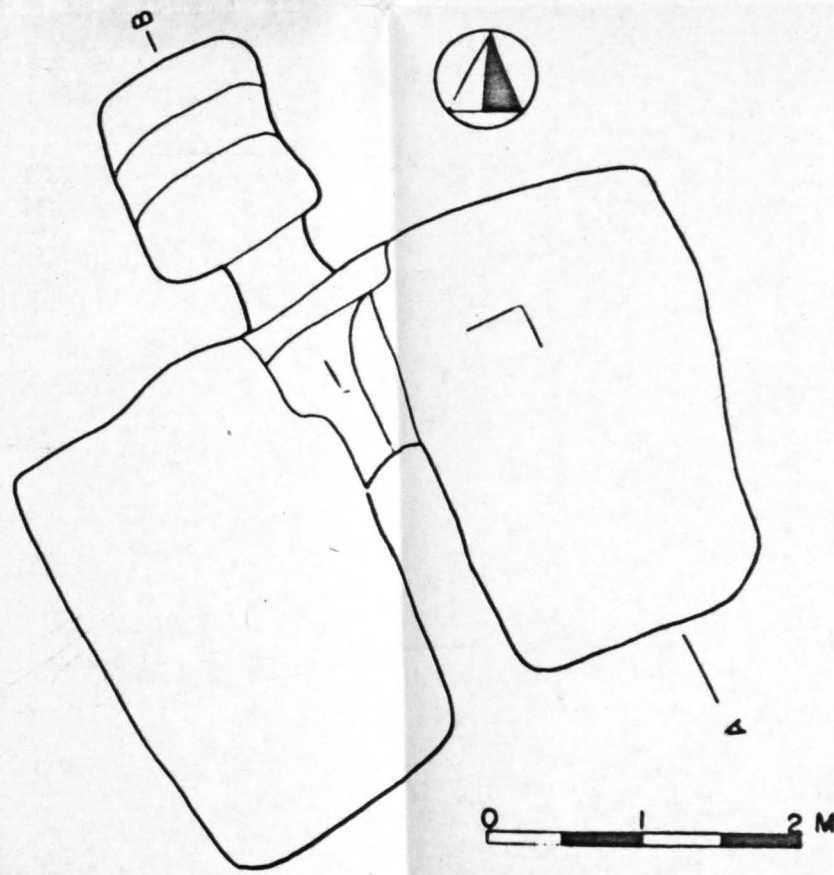

Section

