

Circulation

JOURNAL OF THE AMERICAN HEART ASSOCIATION



Novel Mutation in Desmoplakin Causes Arrhythmogenic Left Ventricular Cardiomyopathy

Mark Norman, Michael Simpson, Jens Mogensen, Anthony Shaw, Sîan Hughes, Petros Syrris, Srijita Sen-Chowdhry, Edward Rowland, Andrew Crosby and William J. McKenna

Circulation 2005;112;636-642

DOI: 10.1161/CIRCULATIONAHA.104.532234

Circulation is published by the American Heart Association, 7272 Greenville Avenue, Dallas, TX 72514

Copyright © 2005 American Heart Association. All rights reserved. Print ISSN: 0009-7322. Online ISSN: 1524-4539

The online version of this article, along with updated information and services, is located on the World Wide Web at:

<http://circ.ahajournals.org/cgi/content/full/112/5/636>

Subscriptions: Information about subscribing to *Circulation* is online at
<http://circ.ahajournals.org/subscriptions/>

Permissions: Permissions & Rights Desk, Lippincott Williams & Wilkins, a division of Wolters Kluwer Health, 351 West Camden Street, Baltimore, MD 21202-2436. Phone: 410-528-4050. Fax: 410-528-8550. E-mail:
journalpermissions@lww.com

Reprints: Information about reprints can be found online at
<http://www.lww.com/reprints>

Novel Mutation in Desmoplakin Causes Arrhythmogenic Left Ventricular Cardiomyopathy

Mark Norman, BSc, MBBS, MRCP; Michael Simpson, BSc; Jens Mogensen, MD, PhD;
Anthony Shaw, PhD; Sïan Hughes, MBBS, PhD, MRCPATH; Petros Syrris, PhD;
Srijita Sen-Chowdhry, MA, MBBS, MRCP; Edward Rowland, MD, FRCP;
Andrew Crosby, PhD; William J. McKenna, MD, DSc, FRCP

Background—Arrhythmogenic right ventricular cardiomyopathy (ARVC) is a familial heart muscle disease characterized by structural, electrical, and pathological abnormalities of the right ventricle (RV). Several disease loci have been identified. Mutations in desmoplakin have recently been isolated in both autosomal-dominant and autosomal-recessive forms of ARVC. Primary left ventricular (LV) variants of the disease are increasingly recognized. We report on a large family with autosomal-dominant left-sided ARVC.

Methods and Results—The proband presented with sudden cardiac death and fibrofatty replacement of the LV myocardium. The family was evaluated. Diagnosis was based on modified diagnostic criteria for ARVC. Seven had inferior and/or lateral T-wave inversion on ECG, LV dilatation, and ventricular arrhythmia, predominantly extrasystoles of LV origin. Three had sustained ventricular tachycardia; 7 had late potentials on signal-averaged ECG. Cardiovascular magnetic resonance imaging in 4 patients revealed wall-motion abnormalities of the RV and patchy, late gadolinium enhancement in the LV, suggestive of fibrosis. Linkage confirmed cosegregation to the desmoplakin intragenic marker D6S2975. A heterozygous, single adenine insertion (2034insA) in the desmoplakin gene was identified in affected individuals only. A frameshift introducing a premature stop codon with truncation of the rod and carboxy terminus of desmoplakin was confirmed by Western blot analysis.

Conclusions—We have described a new dominant mutation in desmoplakin that causes left-sided ARVC, with arrhythmias of LV origin, lateral T-wave inversion, and late gadolinium enhancement in the LV on magnetic resonance images. Truncation of the carboxy terminus of desmoplakin and consequent disruption of intermediate filament binding may account for the predominant LV phenotype. (*Circulation*. 2005;112:636-642.)

Key Words: cardiomyopathy ■ death, sudden ■ genetics ■ arrhythmia ■ cell adhesion molecules

Arrhythmogenic right ventricular cardiomyopathy (ARVC) is a familial heart muscle disease characterized by progressive fibrofatty replacement of the right ventricular (RV) myocardium. Structural abnormalities include myocardial wall thinning, aneurysms, and cavity dilation. Clinical presentation is often with arrhythmia of RV origin or sudden death. Left ventricular (LV) involvement occurs with disease progression and was present on histology in >75% of cases in a multicenter pathological study.¹

ARVC is a genetically heterogeneous disease that is most commonly inherited in an autosomal-dominant fashion. Disease-causing mutations have so far been identified in desmoplakin² and plakophilin,³ both constituents of the specialized adhesive junctions between cells known as desmosomes. Several other disease loci have also been reported.⁴

Autosomal-recessive variants of ARVC have also been described in association with skin and hair disorders. Naxos disease, a triad of ARVC, palmoplantar keratoderma, and woolly hair, is caused by a mutation in plakoglobin,⁵ another component of the desmosomal plaque. Recessive mutations in desmoplakin have been identified in an Arab family with ARVC and a pemphigus-like skin disorder⁶ and in an Ecuadorian family with a Naxos-like cutaneous phenotype and apparent dilated cardiomyopathy, the so-called Carvajal syndrome.⁷ Closer examination of the cardiac disease in Carvajal syndrome reveals aneurysm formation, prominent ventricular arrhythmia, and ECG changes typical of ARVC, with predominant LV involvement.⁸

Left-sided ARVC has recently been recognized on post-mortem examination, with fibrofatty infiltration exclusive to

Received January 20, 2004; de novo received December 27, 2004; revision received April 2, 2005; accepted April 22, 2005.

From the Departments of Cardiological Sciences (M.N., J.M., A.S., E.R., W.J.M.) and of Medical Genetics (M.S., A.C.), St George's Hospital Medical School; the Department of Histopathology (S.H.), Royal Free and University College Medical School, University College London and UCL Hospitals NHS Trust; Cardiology in the Young Program (P.S., S.-S.C., W.J.M.), Heart Hospital, University College London; and the Cardiovascular Magnetic Resonance Unit (S.-S.C.), National Heart and Lung Institute, Imperial College, London, England.

Correspondence to Prof William J. McKenna, The Heart Hospital, 16-18 Westmoreland St, London W1G 8PH, UK. E-mail william.mckenna@uclh.org

© 2005 American Heart Association, Inc.

Circulation is available at <http://www.circulationaha.org>

DOI: 10.1161/CIRCULATIONAHA.104.532234

TABLE 1. Clinical Diagnostic Features in Genetically Affected Individuals

ID	Age	Sex	ECHO, % Pred LVED	LVED, mm	LVES, mm	FS, %	CMR	ECG	SAECG	VT/PVCs per 24 h	Diagnostic Criteria
II:6	67	F	142	64	48	25	ICD in situ	T ↓ II, III, VF, V ₄ -V ₆	Positive	RBBB VT*	2 M + 3 m
III:7	62	F	109	50	28	44	Mildly dilated LV; normal systolic function Normal RV volumes and global function Localized dilation of RV at inflow tract Dyskinesia mid-RV free wall Patchy late gadolinium enhancement at inferolateral LV wall and basal LV septum	T ↓ II, III, VF, V ₄ -V ₆	Negative	RBBB VT	1 M + 2 m
III:10	47	F	120	53	34	36	Claustrophobic	N	Negative	1316 R and L PVCs	2 M + 1 m
III:17	41	F	98	42	26	38	Not available	T ↓ II, III, VF	Positive	7 L PVCs#	1 M + 2 m
III:20	46	F	128	64	45	29	ICD in situ	T ↓ II, III, VF, V ₃ -V ₆	Positive	815 L PVCs*	2 M + 2 m
IV:2	36	M	118	51	35	31	ICD in situ Endomyocardial biopsy showed RV fibrosis	poor R progression V ₁ -V ₂ , T ↓ V ₃	Positive	LBBB VT*	2 M + 2 m
IV:3	39	M	113	50	33	34	Claustrophobic	N	Positive	3661 R and L PVCs	2 M + 2 m
IV:5	31	F	105	48	32	33	Mildly impaired systolic function in LV and RV Aneurysm in mid-free wall of RV with associated myocardial fatty replacement Late gadolinium enhancement at proximal and distal LV septum and inferolateral LV wall	N	Negative	1795 L PVCs	1 M + 1 m
IV:8	36	F	125	54	38	29	Not available	T ↓ II, III, VF, V ₄ -V ₆	Positive	5938 L PVCs	2 M + 3 m
IV:9	28	M	127	58	43	26	Mildly dilated and systolic impairment of LV Regional wall motion abnormalities of LV Localized dilation of RV at inflow tract Patchy late gadolinium enhancement at superolateral, inferolateral, and inferoseptal LV	T ↓ V ₄ -V ₆	Positive	5612 L PVCs	2 M + 3 m
IV:14	22	F	117	54	36	33	Normal biventricular size and function Localized hypokinesia at mid RV free wall Subepicardial late enhancement at basal lateral LV wall	T ↓ II, III, VF	Negative	47 L PVCs	2 M + 1 m

ID indicates individual number on pedigree (Figure 1); M, male; F, female; % Pred LVED, % predicted left ventricular end-diastolic dimension; LVED, left ventricular end-diastolic dimension; LVES, left ventricular end-systolic dimension; FS, fractional shortening; SAECG, signal-averaged ECG; ICD, implantable cardioverter-defibrillator; T ↓, T-wave inversion; Positive, late potentials detected on SAECG; Negative, no late potentials detected on SAECG; VT, sustained (>30 s) ventricular tachycardia; PVC, premature ventricular contraction; LBBB/RBBB, left/right bundle-branch block; M, major criteria; m, minor criteria. # on antiarrhythmic treatment. *Implantable cardioverter defibrillator.

Major criteria include percent predicted LVED >112%, tissue diagnosis of ARVC, and pathologically proven familial disease. Minor criteria include T-wave inversion in 2 contiguous LV leads on ECG, abnormal SAECG, and ventricular extrasystoles >1000/24 hours or sustained VT.

Ten of 11 genetically affected individuals fulfilled the modified diagnostic criteria, resulting in a calculated penetrance of ≈91%.

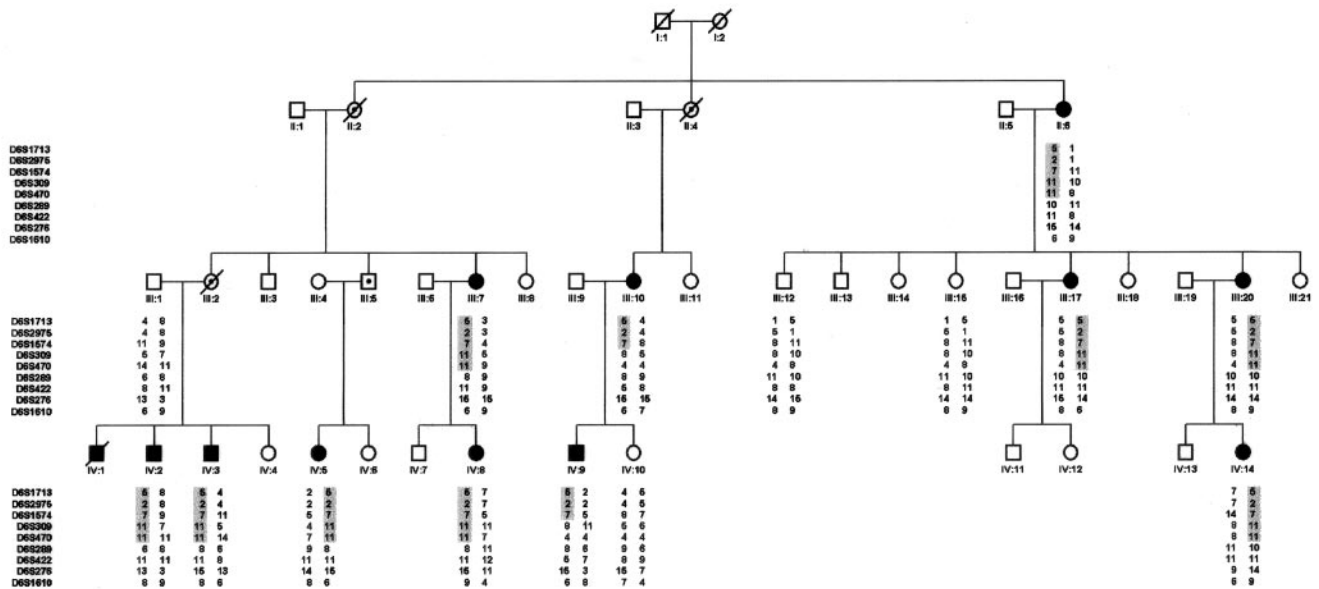

Figure 1. Pedigree of studied family, showing genetically affected males (squares) and females (circles) shown in black. All except IV:5 fulfilled diagnostic criteria for ARVC with LV involvement. Two individuals without mutation had mild LV enlargement (113% to 115%), with normal ECG and Holter monitor data. Four obligate carriers were not available for evaluation (dotted open square or circle).

the LV,⁹ and in vivo,¹⁰ although case numbers remain small. To our knowledge, genotype-phenotype correlations in autosomal-dominant arrhythmogenic left ventricular cardiomyopathy (ALVC) have not hitherto been investigated. Herein we report on a large family with autosomal-dominant ALVC caused by a novel frameshift mutation in desmoplakin.

Methods

Patients and Clinical Variables

The study was approved by the local research ethics committee, and all individuals gave written, informed consent. Clinical evaluation included 12-lead ECG, signal-averaged ECG, 2-dimensional echocardiography, maximal exercise testing according to standard protocols, and 24-hour ambulatory ECG monitoring. Conventional time domain criteria were used to determine an abnormal signal-averaged ECG.¹¹ LV dilation was defined as an LV end-diastolic dimension >2 SD above normal, according to the formula predicted by Henry et al¹² for age, sex, and weight. Diagnosis was based on a modification of the proposed European Society of Cardiology/International Society and Federation of Cardiology diagnostic criteria for ARVC.¹³ T-wave abnormalities in 2 or more LV leads were included as a minor criterion, and otherwise-unexplained structural alteration of the LV rather than the RV was considered a major criterion (Table 1).

Genetic Studies

Genomic DNA was extracted from whole blood. A genome-wide scan was performed with the MD-10 marker set. Linkage analysis of the resultant genotyping was performed with MLINK (LINKAGE package 5.1, available at <http://www.hgmp.mrc.ac.uk>), assuming a gene frequency of 1:10 000 and 90% penetrance. Polymerase chain reaction (PCR) products derived from the 24 coding exons of the cardiac desmoplakin isoform were amplified from a single affected individual (DPI; available at www.ncbi.nlm.nih.gov; primers available on request); both linkage and sequence analyses were performed on an ABI Prism 3100 sequencer (Applied Biosystems).

Biochemistry

Skin biopsies were obtained from patient IV:9 and a control subject. Cellular protein was extracted by powdering the tissue under LN₂

and then vortexing the powder in 8 mol/L urea, 2% sodium dodecyl sulfate, 10 mmol/L CHAPS, and 250 mmol/L Tris, pH 8.0. Insoluble material was pelleted by centrifugation, and the protein concentration of the supernatant was determined by Bio-Rad protein assay reagents as per the manufacturer’s instructions. The total protein isolated from the patient and control samples was resolved on a denaturing 12% polyacrylamide gel and blotted onto a nitrocellulose membrane according to standard techniques. Desmoplakin was detected with the NW161 antibody, which is specific for an epitope within the first 189 amino acids at the N-terminal of desmoplakin. The secondary antibody was a horseradish peroxidase–labeled swine anti-rabbit IgG (Dako). Blots were developed with ECL reagents (Amersham).

Cardiovascular Magnetic Resonance

After mutation analysis, 4 gene carriers were evaluated with a newly developed comprehensive cardiovascular magnetic resonance (CMR) protocol. The remainder were not eligible because of prior implantation of a cardioverter-defibrillator, claustrophobia, or geographic relocation.

CMR was performed on a 1.5-T Siemens Sonata scanner. Images were acquired in standard views: 4-chamber, 2-chamber, LV outflow tract, and RV outflow tract; sequential short-axis slices from the level of the atrioventricular valves to the apex; and sequential transverse slices. The sequences and parameters used were as follows: (1) fast imaging with steady-state, free precession, cine loops (retrospective ECG gating, high temporal resolution with 45 phases per cardiac cycle, 7-mm slice thickness, and 3-mm interslice gap for short-axis and transverse stacks); (2) T1-weighted turbo spin-echo images (6-mm slice thickness, 4-mm interslice gap); and (3) T2-weighted, short tau-inversion recovery for fat suppression (8-mm slice thickness, 2-mm interslice gap).

A peripheral bolus injection of gadolinium-DTPA (0.1 mmol/kg) was subsequently administered. Delayed-enhancement images were obtained with a segmented inversion-recovery sequence, with a 90° presaturation pulse placed over the cerebrospinal fluid to eliminate artifact. Standard long-axis and all short-axis views were acquired twice with different phase-encoding directions and careful optimization of inversion times.

Image Analysis

Ventricular volumes and function were assessed from the serial short-axis, true fast imaging with steady-state, free precession, cine

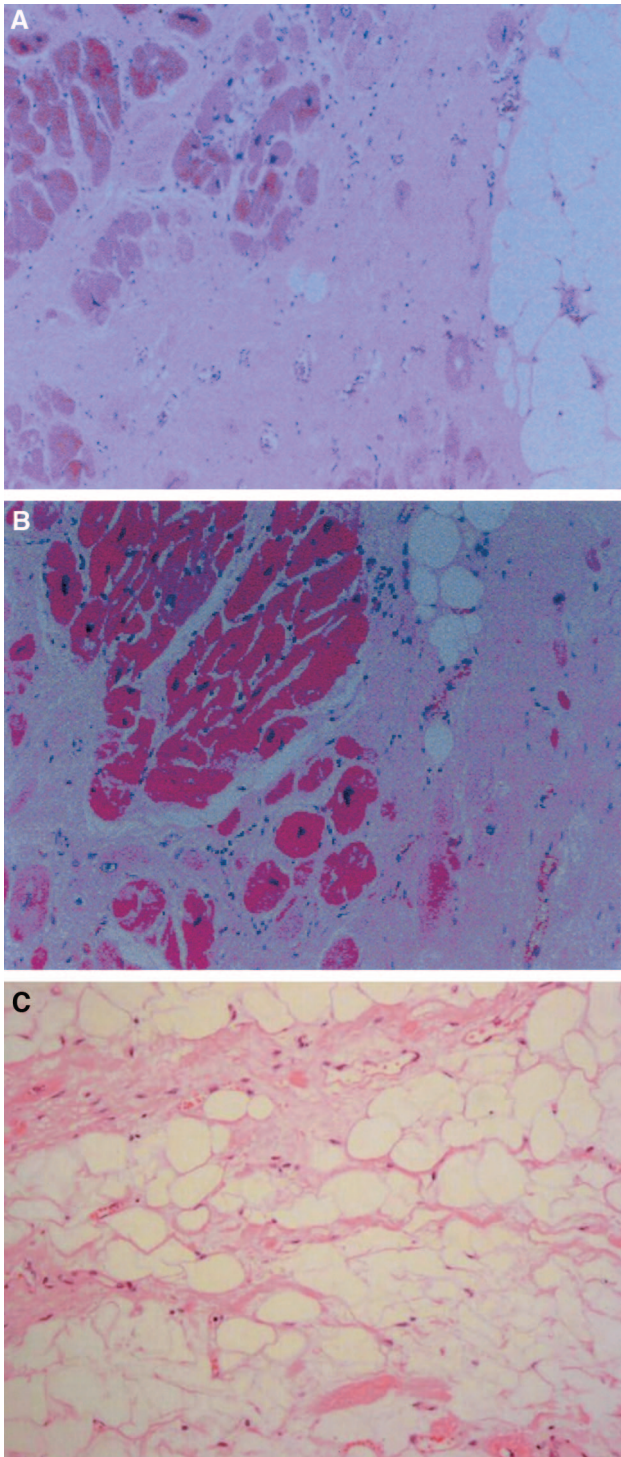

Figure 2. Histological example of LV myocardium from proband IV:1, showing myocyte loss with fibrofatty replacement (Hematoxylin and eosin staining). A, Low-power ($\times 4$) view; B, slightly higher low-power ($\times 10$) view; C, high-power view ($\times 20$).

loops with the use of in-house software (CMR Tools, Imperial College). Myocardial fatty replacement was recognized in the presence of a high T1 signal on turbo spin-echo images, with fat suppression on corresponding short tau-inversion recovery images. Delayed gadolinium enhancement was considered present when both of the following criteria were fulfilled: (1) detection in the same slice after swapping phase encoding, thereby eliminating artifact, and (2)

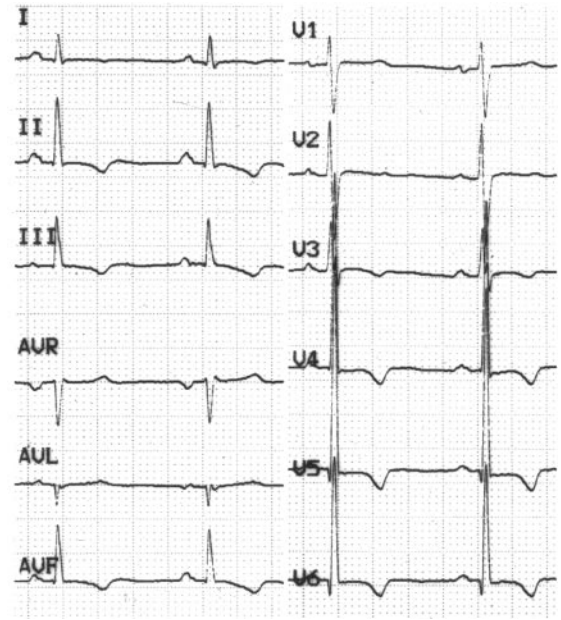

Figure 3. Typical resting 12-lead ECG findings with inferior and lateral T-wave inversion.

absence of fat in the same location on the corresponding T1-weighted turbo spin-echo image.

Results

Clinical Investigations

The pedigree is shown in Figure 1. The proband, a 19-year-old white male (individual IV:1) presented with sudden cardiac death. Postmortem examination demonstrated focal areas of fibrosis in the LV, in a predominantly subpericardial distribution. Adipose infiltration was also present (Figure 2). Twenty-seven family members were evaluated.

Ten individuals fulfilled the modified diagnostic criteria for ARVC with predominant LV involvement (Table 1). Seven had inferior and/or lateral T-wave inversion on the 12-lead ECG (Figure 3). Seven had late potentials on signal-averaged ECG. Eight had ventricular arrhythmia, predominantly extrasystoles of right bundle-branch-block configuration, consistent with LV origin. Three had exercise-related syncope with documented spontaneous ventricular tachycardia; 2 of these had ventricular extrasystoles of both LV and RV origin. The LV wall thickness was within normal limits in all cases. Eight patients had LV dilation, whereas only 1 had RV enlargement on echocardiography. Signs and symptoms of heart failure were absent, and none had clinical evidence of overt hair or skin abnormalities. The 4 patients who underwent CMR had patchy, late gadolinium enhancement in the LV (Figure 4A), suggestive of fibrosis, and regional dilation, hypokinesia, and/or aneurysm formation in the RV (Figure 4B).

Linkage Analysis

Because the penetrance of ARVC is low ($\approx 30\%$) and the family had a sufficient number of affected individuals, a genome-wide scan with an affected-only analysis was used to map the causative gene. This identified a single disease locus

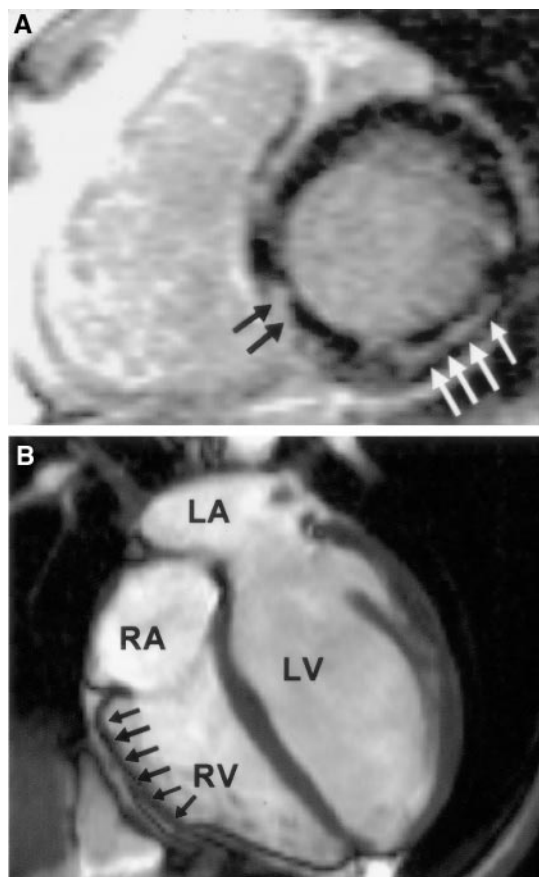

Figure 4. CMR images from 2 patients (III:7 and IV:9). A, Late gadolinium enhancement at inferolateral LV wall (white arrows) and septum (black arrows). B, Localized dilation in subtricuspid region (black arrows) of RV. This segment was markedly hypokinetic during systole. RA indicates right atrium; LA, left atrium.

on chromosome 6 (Table 2), flanked distally by the telomere and proximally by marker D6S309. Desmoplakin was a plausible candidate gene, and an intragenic microsatellite repeat, D6S2975, was used to assess the involvement of this gene (Table 2 and Figure 5). This marker showed complete cosegregation with the disease phenotype (2-point log-of-the-odds [LOD] score of 3.7). LOD scores were not affected by varying allele frequencies.

Mutation Analysis

Direct sequencing of the coding region of the desmoplakin gene identified insertion of a single adenine base (2034insA,

TABLE 2. Two-Point LOD Scores for Family

Locus $\theta=$	Recombination Fraction						
	0	0.01	0.05	0.1	0.2	0.3	0.4
D6S2975	3.7	3.63	3.34	2.96	2.17	1.34	0.55
D6S1574	3.69	3.62	3.34	2.98	2.21	1.4	0.58
D6S309	-1.76	1.02	1.48	1.48	1.15	0.67	0.2
D6S470	-1.25	1.53	1.99	1.99	1.63	1.09	0.47

Two-point LOD scores were calculated assuming autosomal dominant inheritance, disease allele frequency of 0.001, equal male and female recombination frequencies, and 90% penetrance.

based on the published cDNA sequence for desmoplakin; GenBank M77830). This was predicted to alter a histidine-to-threonine residue at amino acid position 586, causing a frameshift and introduction of a premature stop codon 8 residues downstream (T586fsX594). The 2034insA mutation introduces an *MseI* restriction enzyme site. The mutation was confirmed by restriction digestion in samples from all affected individuals and was not present in 140 chromosomes from ethnically matched controls. Transcription of both the wild-type and the truncated protein product in affected individuals was confirmed by Western blot (Figure 6).

Discussion

ARVC was originally described in young people presenting with arrhythmias of RV origin.¹⁴ Fibrofatty replacement of the RV myocardium is the main pathological feature. Although LV involvement is common in advanced disease,¹ variants of ARVC that preferentially affect the LV have only recently been recognized.^{9,10}

Dilated cardiomyopathy (DCM) is characterized by dilation and systolic impairment of the LV, with or without RV involvement. Typical histological changes include inflammatory infiltrates, myocyte loss, and fibrosis. In both ARVC and DCM, the histology is thought to reflect myocyte damage and death, accompanied by inflammation and fibrotic repair. CMR of patients with DCM often shows midwall late gadolinium enhancement, consistent with fibrosis.¹⁵ DCM is a genetically heterogeneous disease, but defects in cytoskeletal proteins, including intermediate filaments, are recognized.¹⁶

We report a family with autosomal-dominant, left-sided ARVC caused by a frameshift mutation in desmoplakin. Fibrofatty replacement of the LV myocardium was apparent on autopsy of the proband. Familial evaluation revealed arrhythmias of LV origin, repolarization abnormalities in the LV leads (V_4 to V_6), and LV dilation on echocardiography. CMR demonstrated RV changes typical of ARVC, including localized dilation and hypokinesia, aneurysms, and myocardial fatty replacement. However, the most prominent CMR finding was marked patchy, late gadolinium enhancement in the LV myocardium, highly suggestive of fibrosis.

Desmoplakin is a desmosomal plaque protein with 3 separate domains: the amino terminus, which associates with other proteins in the outer dense plaque of the desmosome, including plakoglobin, desmocollin, desmoglein and plakophilin; the rod; and the carboxy terminus, which interacts with the intermediate filament desmin in the myocardium. A missense mutation in the amino-terminal, plakoglobin-binding domain has been reported in a family with typical RV cardiomyopathy.^{2,3,5} Loss of desmosome integrity is considered central to the pathogenesis of ARVC; impaired cell-cell adhesion predisposes to myocyte detachment and death, with fibrofatty repair. Preferential involvement of the RV may be a consequence of its thinner walls, which render it more susceptible to mechanical stress and dependent on normal desmosomal function for maintaining tissue integrity.

The 2034insA mutation is located in the amino terminus of desmoplakin and causes insertion of a premature stop codon, with consequent truncation of the rod and carboxy terminus

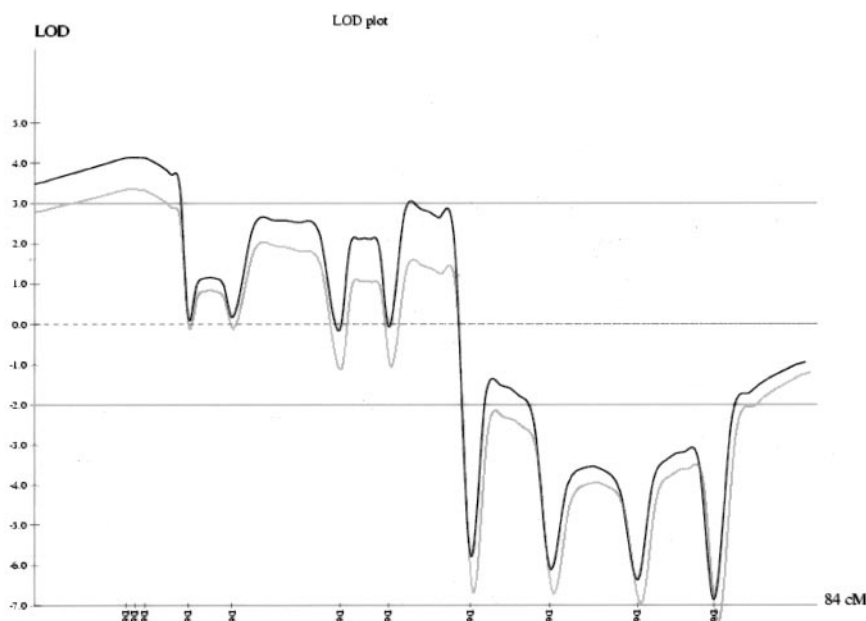

Figure 5. Multipoint LOD score curve derived from linkage analysis of indicated markers. cM indicates centi-Morgan.

of the protein. The potential functional impact of this mutation is 2-fold: impaired cell adhesion at the amino terminus and disrupted binding to desmin, owing to loss of the carboxy terminus. This resulted in a peculiar phenotype in the family studied: structural abnormalities typical of ARVC in the RV but conspicuous early left-sided manifestations, including LV arrhythmia, ECG abnormalities, dilation, and fibrosis. Indeed, the cardiac phenotype resembles that of Carvajal syndrome, with LV dilation and fibrosis occurring in conjunction with RV aneurysms in the triangle of dysplasia.⁸ The recessive 7901delG mutation of Carvajal syndrome likewise leads to truncation of the carboxy terminus of desmoplakin. Confocal immunofluorescence of a Carvajal heart has demonstrated failure of desmin to localize to intercalated disks, a likely corollary of impaired binding to desmoplakin. In the LV, normal functioning of the cytoskeleton may be critical for protecting myocytes from high left-sided pressures.

None of the patients studied had clinical evidence of overt cutaneous disease. Cutaneous manifestations have hitherto been observed in homozygotes with recessive mutations in

desmoplakin.^{6,7} Immunohistochemistry of a palmar skin biopsy from a patient with Carvajal syndrome revealed an abnormal distribution of desmoplakin, plakoglobin, and type II keratin in suprabasal keratinocytes. Heterozygous carriers were not affected. However, desmoplakin has been implicated in autosomal-dominant striate palmoplantar keratoderma^{17,18} Of note, the causative mutations in desmoplakin were not detectable by conventional reverse transcription-PCR and cDNA sequencing, consistent with nonsense-mediated mRNA decay and haploinsufficiency. This has led to the hypothesis that a normal dose of desmoplakin is requisite for maintaining epidermal integrity at stress-prone sites.¹⁷ In the family described, Western blot analysis demonstrated the presence of both mutant and wild-type proteins. We can speculate that expression of sufficient quantities of desmoplakin, albeit partly in mutant form, confers protection from palmoplantar keratoderma. The exact mechanisms underlying development of cardiac and cutaneous disease are likely to be complex; further elucidation will require extensive functional studies and detailed phenotypic evaluation of large kindreds.

Unraveling of the genetic etiology of heart muscle diseases in the past decade has provided important insight into their pathogenesis. Ultimately, the cardiomyopathies may be classified on the basis of underlying molecular genetics, with descriptive clinical features to guide evaluation and management. If so, this family would best be described as having desmosome-intermediate filament disease, with truncation of the carboxy terminus of desmoplakin resulting in ALVC.

Acknowledgments

Prof McKenna and Drs Sen-Chowdhry, Syrris, Mogensen, and Norman were supported by the British Heart Foundation. Dr Norman received additional support from a Bristol Myers Squibb Fellowship. This ongoing work was supported by European Community Research Contract No. QLG1-CT-2000-01091.

References

1. Corrado D, Basso C, Thiene G, McKenna WJ, Davies MJ, Fontaliran F, Nava A, Silvestri F, Blomstrom-Lundqvist C, Wlodarska EK, Fontaine G,

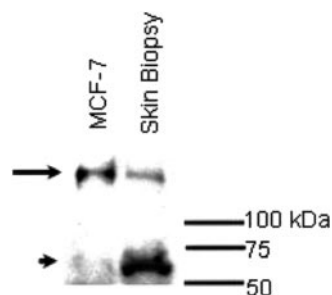

Figure 6. Western blot from skin sample of individual IV:9, showing both wild-type and truncated form of desmoplakin at ≈ 65 kDa, which corresponds to calculated molecular mass of truncated protein produced by 2034insA mutation. The human breast adenocarcinoma cell line MCF-7 (American Type Culture Collection), which highly expresses desmoplakin, was used as control.

- Camerini F. Spectrum of clinicopathologic manifestations of arrhythmogenic right ventricular cardiomyopathy/dysplasia: a multicenter study. *J Am Coll Cardiol*. 1997;30:1512–1520.
2. Rampazzo A, Nava A, Malacrida S, Boffagna G, Bauce B, Rossi V, Zimbello R, Simionati B, Basso C, Thiene G, Towbin JA, Danieli GA. Mutation in human desmoplakin domain binding to plakoglobin causes a dominant form of arrhythmogenic right ventricular cardiomyopathy. *Am J Hum Genet*. 2002;71:1200–1206.
 3. Gerull B, Heuser A, Wichter T, Paul M, Basson CT, McDermott DA, Lerman BB, Markowitz SM, Ellinor PT, MacRae CA, Peters S, Grossmann KS, Drenckhahn J, Michely B, Sasse-Klaassen S, Birchmeier W, Dietz R, Breithardt G, Schulze-Barr E, Thierfelder L. Mutations in the desmosomal protein plakophilin-2 are common in arrhythmogenic right ventricular cardiomyopathy. *Nat Genet*. 2004;36:1162–1164. Erratum in *Nat Genet*. 2005;37:106.
 4. Fatkin D, Graham RM. Molecular mechanisms of inherited cardiomyopathies. *Physiol Rev*. 2002;82:945–980.
 5. McKoy G, Protonotarios N, Crosby A, Tsatsopoulou A, Anastasakis A, Coonar A, Norman M, Baboonian C, Jeffery S, McKenna WJ. Identification of a deletion in plakoglobin in arrhythmogenic right ventricular cardiomyopathy with palmoplantar keratoderma and woolly hair (Naxos disease). *Lancet*. 2000;355:2119–2124.
 6. Alcalai R, Metzger S, Rosenheck S, Meiner V, Chajek-Shaul T. A recessive mutation in desmoplakin causes arrhythmogenic right ventricular dysplasia, skin disorder, and woolly hair. *J Am Coll Cardiol*. 2003;42:319–327.
 7. Norgett EE, Hatsell SJ, Carvajal-Huerta L, Cabezas JC, Common J, Purkis PE, Whittock N, Leigh IM, Stevens HP, Kelsell DP. Recessive mutation in desmoplakin disrupts desmoplakin-intermediate filament interactions and causes dilated cardiomyopathy, woolly hair and keratoderma. *Hum Mol Genet*. 2000;9:2761–2766.
 8. Protonotarios N, Tsatsopoulou A. Naxos disease and Carvajal syndrome: cardiocutaneous disorders that highlight the pathogenesis and broaden the spectrum of arrhythmogenic right ventricular cardiomyopathy. *Cardiovasc Pathol*. 2004;13:185–194.
 9. Michalodimitrakis M, Papadomanolakis A, Stiakakis J, Kanaki K. Left side right ventricular cardiomyopathy. *Med Sci Law*. 2002;42:313–317.
 10. De Pasquale CG, Heddle WF. Left sided arrhythmogenic ventricular dysplasia in siblings. *Heart*. 2001;86:128–130.
 11. Breithardt G, Cain ME, el Sherif N, Flowers NC, Hombach V, Janse M, Simson MB, Steinbeck G. Standards for analysis of ventricular late potentials using high-resolution or signal-averaged electrocardiography: a statement by a Task Force Committee of the European Society of Cardiology, the American Heart Association, and the American College of Cardiology. *Circulation*. 1991;83:1481–1488.
 12. Henry WL, Gardin JM, Ware JH. Echocardiographic measurements in normal subjects from infancy to old age. *Circulation*. 1980;62:1054–1061.
 13. McKenna WJ, Thiene G, Nava A, Fontaliran F, Blomstrom-Lundqvist C, Fontaine G, Camerini F. Diagnosis of arrhythmogenic right ventricular dysplasia/cardiomyopathy. Task Force of the Working Group Myocardial and Pericardial Disease of the European Society of Cardiology and of the Scientific Council on Cardiomyopathies of the International Society and Federation of Cardiology. *Br Heart J*. 1994;71:215–218.
 14. Fontaine G, Guiraudon G, Frank R, Vedel J, Grosgeat Y, Cabrol C, Facquet J. Stimulation studies and epicardial mapping in ventricular tachycardia: study of mechanisms and selection for surgery. In: Kulbertus HE, ed. *Reentrant Arrhythmias: Mechanisms and Treatment*. Lancaster, Pa: MTP Press Ltd; 1977:334–350.
 15. McCrohon JA, Moon JC, Prasad SK, McKenna WJ, Lorenz CH, Coats AJ, Pennell DJ. Differentiation of heart failure related to dilated cardiomyopathy and coronary artery disease using gadolinium-enhanced cardiovascular magnetic resonance. *Circulation*. 2003;108:54–59.
 16. Towbin JA, Bowles NE. The failing heart. *Nature*. 2002;415:227–233.
 17. Armstrong DK, McKenna KE, Purkis PE, Green KJ, Eady RA, Leigh IM, Hughes AE. Haploinsufficiency of desmoplakin causes a striate subtype of palmoplantar keratoderma. *Hum Mol Genet*. 1999;8:143–148.
 18. Whittock NV, Ashton GH, Dopping-Hepenstal PJ, Gratian MJ, Keane FM, Eady RA, McGrath JA. Striate palmoplantar keratoderma resulting from desmoplakin haploinsufficiency. *J Invest Dermatol*. 1999;113:940–946.